



STX93003

HIGH VOLTAGE FAST-SWITCHING PNP POWER TRANSISTOR

- ST93003 SILICON IN TO-92 PACKAGE
- MEDIUM VOLTAGE CAPABILITY
- LOW SPREAD OF DYNAMIC PARAMETERS
- MINIMUM LOT-TO-LOT SPREAD FOR RELIABLE OPERATION
- VERY HIGH SWITCHING SPEED

APPLICATIONS:

- ELECTRONIC BALLASTS FOR FLUORESCENT LIGHTING

DESCRIPTION

The device is manufactured using high voltage Multi-Epitaxial Planar technology for high switching speeds and medium voltage capability. It uses a Cellular Emitter structure with planar edge termination to enhance switching speeds while maintaining the wide RBSOA.

The STX93003 is expressly designed for a new solution to be used in compact fluorescent lamps, where it is coupled with the STX83003, its complementary NPN transistor.

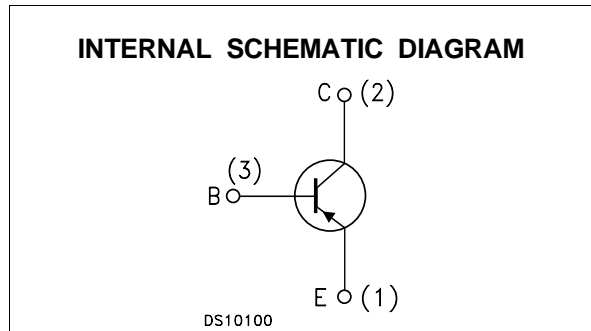
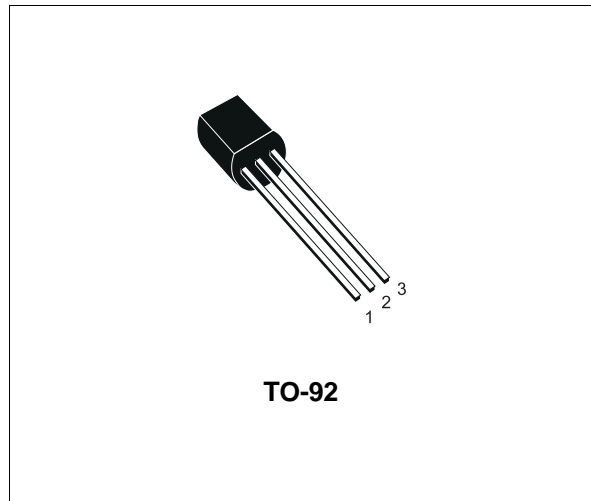

ABSOLUTE MAXIMUM RATINGS

| Symbol | Parameter | Value | Unit |
|-----------|---|---------------|------------|
| V_{CES} | Collector-Emitter Voltage ($V_{BE} = 0$) | -500 | V |
| V_{CEO} | Collector-Emitter Voltage ($I_B = 0$) | -400 | V |
| V_{EBO} | Emitter-Base Voltage ($I_C = 0$) ($I_C = 0$, $I_B = -0.5$ A, $t_p < 10\mu s$, $T_j < 150^\circ C$) | $V_{(BR)EBO}$ | V |
| I_C | Collector Current | -1 | A |
| I_{CM} | Collector Peak Current ($t_p < 5$ ms) | -3 | A |
| I_B | Base Current | -0.5 | A |
| I_{BM} | Base Peak Current ($t_p < 5$ ms) | -1.5 | A |
| P_{tot} | Total Dissipation at $T_C = 25^\circ C$ | 1.5 | W |
| T_{stg} | Storage Temperature | -65 to 150 | $^\circ C$ |
| T_j | Max. Operating Junction Temperature | 150 | $^\circ C$ |

THERMAL DATA

| | | | | |
|-----------------------|-------------------------------------|-----|------|------|
| R _{thj-case} | Thermal Resistance Junction-Case | Max | 83.3 | °C/W |
| R _{thj-Amb} | Thermal Resistance Junction-Ambient | Max | 200 | °C/W |

ELECTRICAL CHARACTERISTICS (T_{case} = 25 °C unless otherwise specified)

| Symbol | Parameter | Test Conditions | Min. | Typ. | Max. | Unit | |
|--|---|---|------|--|--------------|------------------|----------------|
| I _{CES} | Collector Cut-off Current (V _{BE} = 0) | V _{CE} = -500V V _{CE} = -500V T _j = 125°C | | | -1 -5 | mA mA | |
| V _{(BR)EBO} | Emitter Base Breakdown Voltage (I _C = 0) | I _E = -10 mA | -5 | | -10 | V | |
| V _{CEO(sus)*} | Collector-Emitter Sustaining Voltage (I _B = 0) | I _C = -10 mA L = 25 mH | -400 | | | V | |
| V _{CE(sat)*} | Collector-Emitter Saturation Voltage | I _C = -0.5 A I _C = -0.35 A | | | -0.5 -0.5 | V V | |
| V _{BE(sat)*} | Base-Emitter Saturation Voltage | I _C = -0.5 A I _B = -0.1 A | | | -1 | V | |
| h _{FE*} | DC Current Gain | I _C = -10 mA I _C = -0.35 A I _C = -1 A | | 10 16 4 | 25 32 | | |
| t _r t _s t _f | RESISTIVE LOAD Rise Time Storage Time Fall Time | I _C = -0.35 A I _{B1} = -70 mA T _p ≥ 25 μs | | V _{CC} = 125 V I _{B2} = 70 mA (see Figure 2) | 1.5 | 90 2.2 0.1 | ns μs μs |
| t _s t _f | INDUCTIVE LOAD Storage Time Fall Time | I _C = -0.5 A V _{BE(off)} = 5 V V _{clamp} = 300 V | | I _{B1} = -0.1 A L = 10 mH (see Figure 1) | | 400 40 | ns ns |
| E _{sb} | Avalanche Energy | L = 4 mH I _{BR} ≤ 2.5 A | | C = 1.8 nF 25°C < T _C < 125°C | 12 | | mJ |

* Pulsed: Pulse duration = 300μs, duty cycle = 1.5 %.

Safe Operating Area

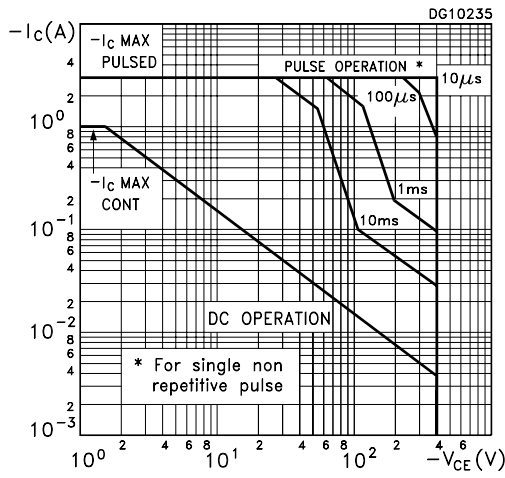

Derating Curve

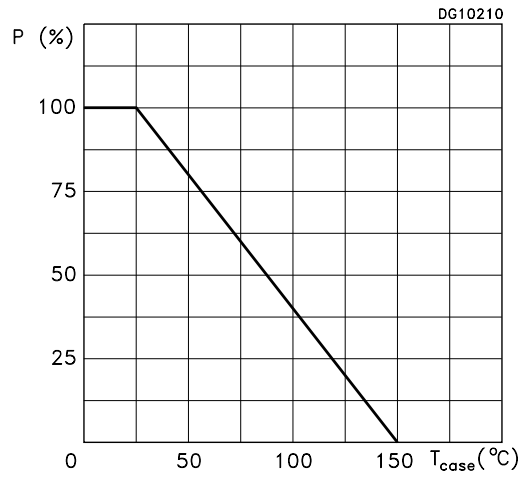

DC Current Gain

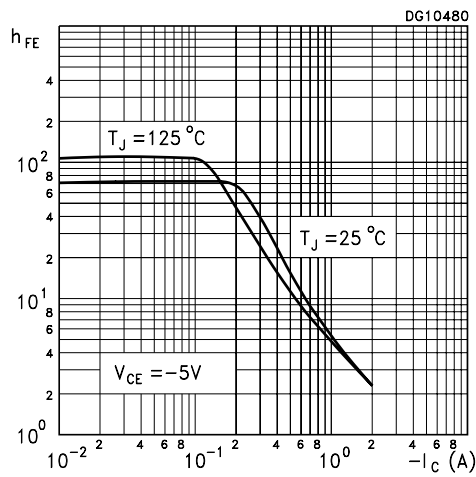

DC Current Gain

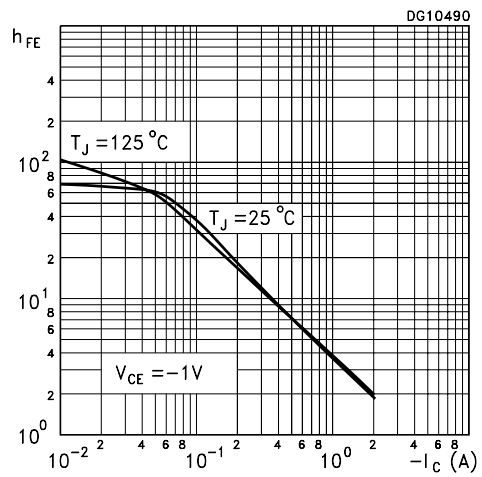

Collector Emitter Saturation Voltage

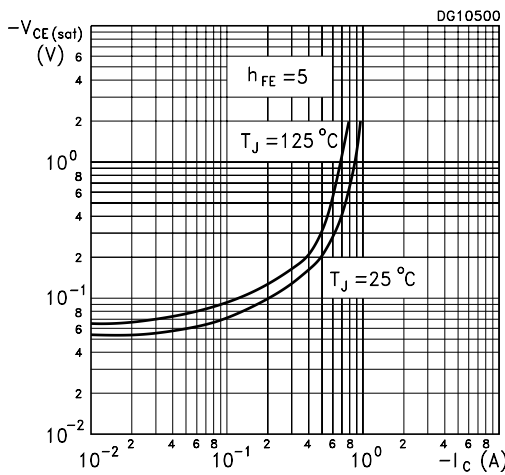

Base Emitter Saturation Voltage

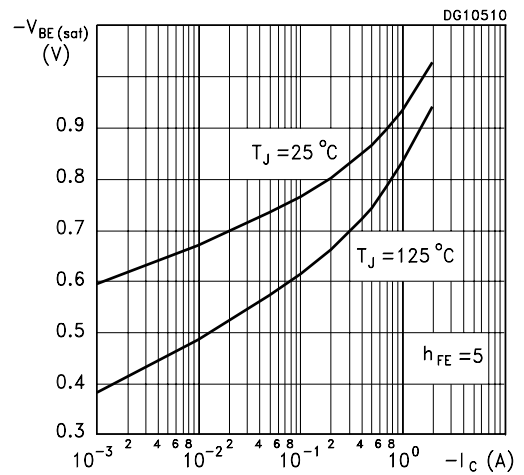

Resistive Load Fall Time

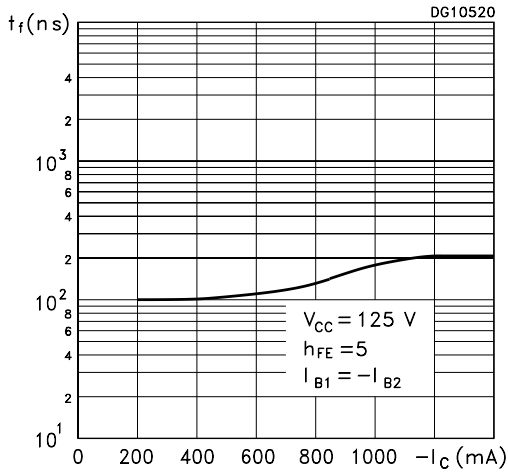

Resistive Load Storage Time

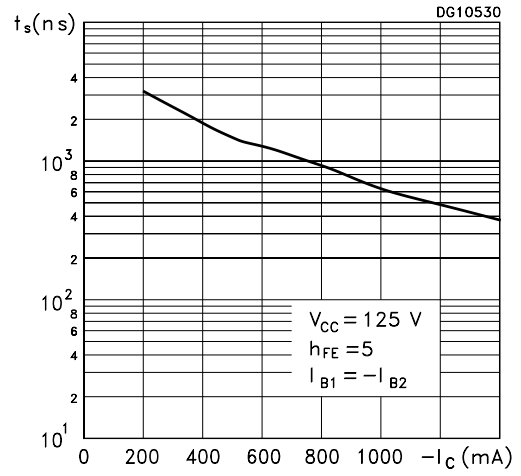

Inductive Load Fall Time

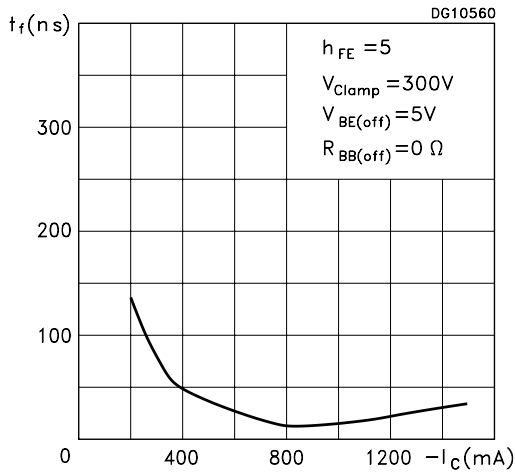

Inductive Load Storage Time

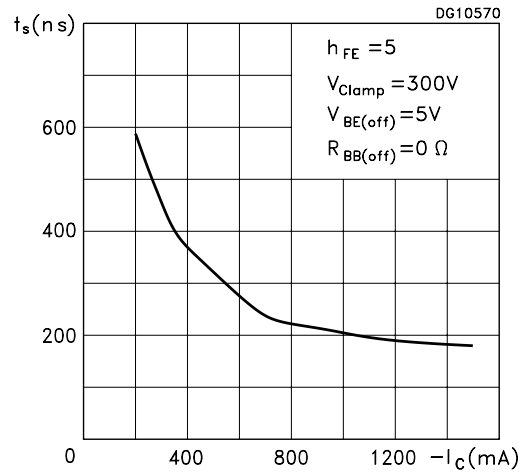

Reverse Biased SOA

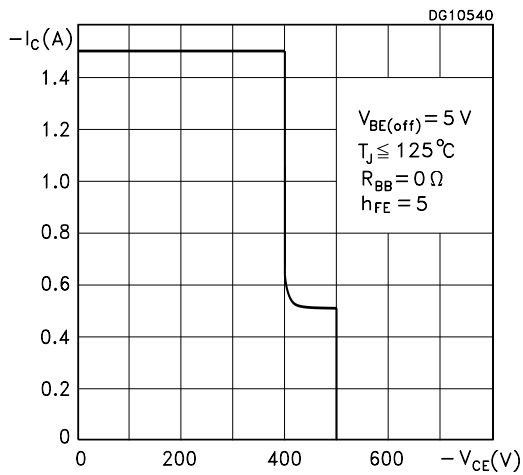

Figure 1: Inductive Load Switching Test Circuit.

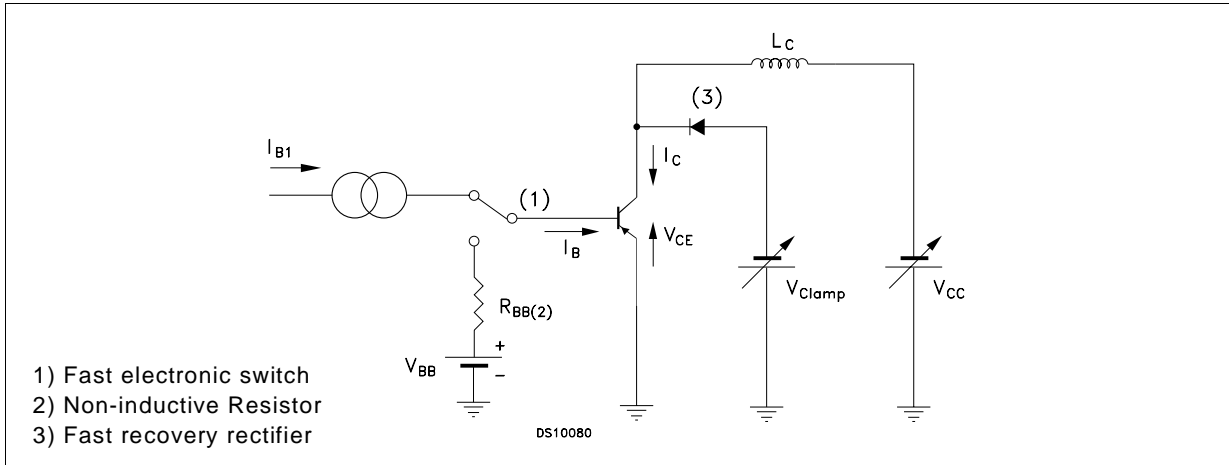
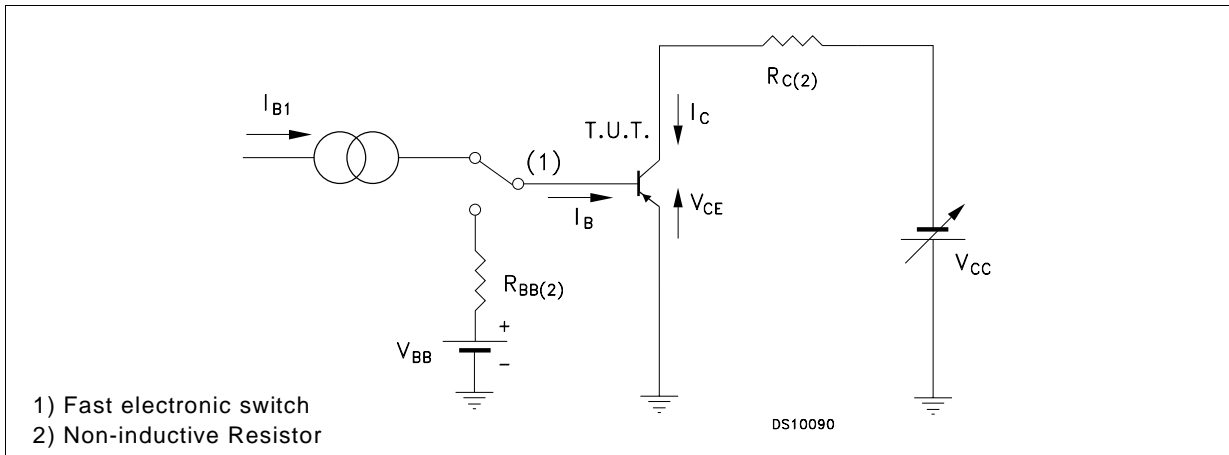
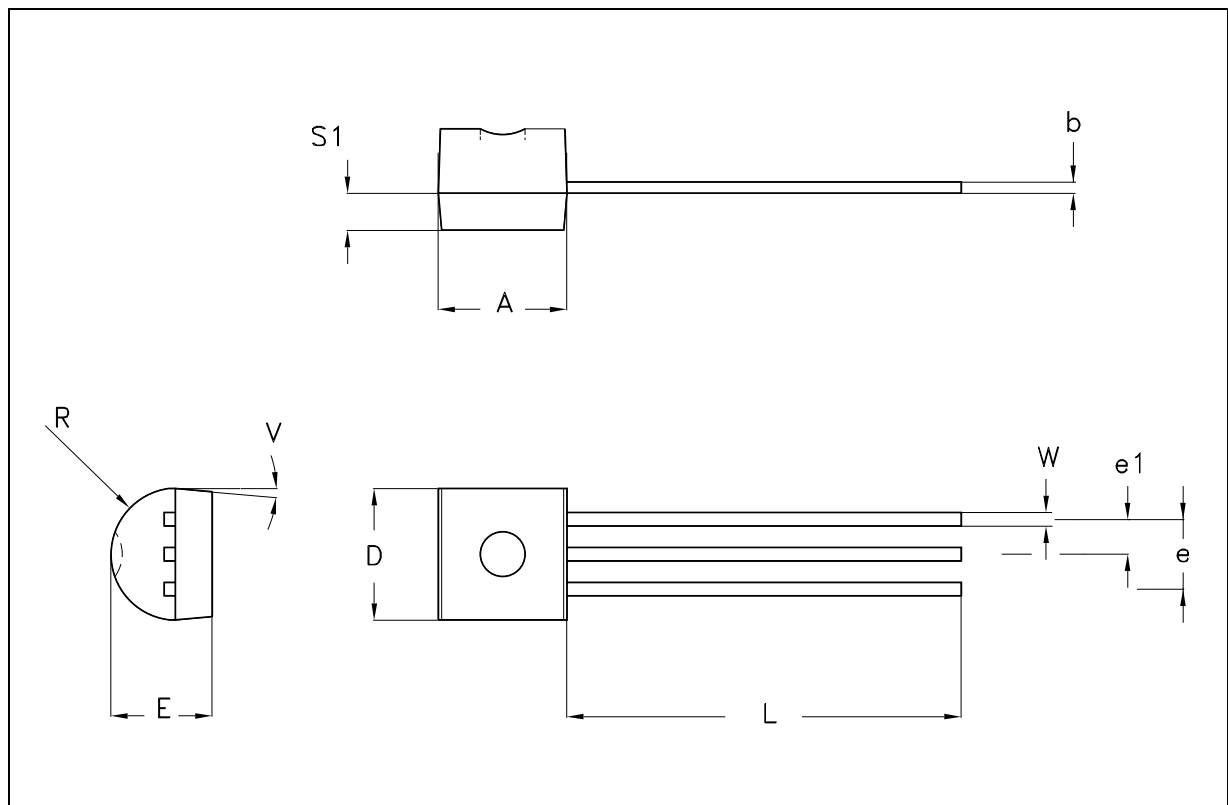

Figure 2: Resistive Load Switching Test Circuit.



TO-92 MECHANICAL DATA

| DIM. | mm | | | inch | | |
|------|----------|------|----------|----------|------|----------|
| | MIN. | TYP. | MAX. | MIN. | TYP. | MAX. |
| A | 4.32 | | 4.95 | 0.170 | | 0.195 |
| b | 0.36 | | 0.51 | 0.014 | | 0.020 |
| D | 4.45 | | 4.95 | 0.175 | | 0.194 |
| E | 3.30 | | 3.94 | 0.130 | | 0.155 |
| e | 2.41 | | 2.67 | 0.095 | | 0.105 |
| e1 | 1.14 | | 1.40 | 0.045 | | 0.055 |
| L | 12.70 | | 15.49 | 0.500 | | 0.609 |
| R | 2.16 | | 2.41 | 0.085 | | 0.094 |
| S1 | 1.14 | | 1.52 | 0.045 | | 0.059 |
| W | 0.41 | | 0.56 | 0.016 | | 0.022 |
| V | 4 degree | | 6 degree | 4 degree | | 6 degree |



Information furnished is believed to be accurate and reliable. However, STMicroelectronics assumes no responsibility for the consequences of use of such information nor for any infringement of patents or other rights of third parties which may result from its use. No license is granted by implication or otherwise under any patent or patent rights of STMicroelectronics. Specification mentioned in this publication are subject to change without notice. This publication supersedes and replaces all information previously supplied. STMicroelectronics products are not authorized for use as critical components in life support devices or systems without express written approval of STMicroelectronics.

The ST logo is a trademark of STMicroelectronics

© 2002 STMicroelectronics – Printed in Italy – All Rights Reserved

STMicroelectronics GROUP OF COMPANIES

Australia - Brazil - Canada - China - Finland - France - Germany - Hong Kong - India - Israel - Italy - Japan - Malaysia - Malta - Morocco - Singapore - Spain - Sweden - Switzerland - United Kingdom - United States.

<http://www.st.com>



AMEYA360

Components Supply Platform

Authorized Distribution Brand :



Website :

Welcome to visit www.ameya360.com

Contact Us :

➤ Address :

401 Building No.5, JiuGe Business Center, Lane 2301, Yishan Rd
Minhang District, Shanghai , China

➤ Sales :

Direct +86 (21) 6401-6692

Email amall@ameya360.com

QQ 800077892

Skype [ameyasales1](#) [ameyasales2](#)

➤ Customer Service :

Email service@ameya360.com

➤ Partnership :

Tel +86 (21) 64016692-8333

Email mkt@ameya360.com