Six-channel QTouch® Touch Sensor IC

DATASHEET

Features

- Configurations:
 - Can be configured as a combination of keys and input/output lines
- Number of QTouch® Keys:
 - Two to six
- Number of I/O Lines:
 - Seven, configurable for input or output, with PWM control for LED driving
- Technology:
 - Patented spread-spectrum charge-transfer (direct mode)
- Key Outline Sizes:
 - 6 mm x 6 mm or larger (panel thickness dependent); widely different sizes and shapes possible
- Layers Required:
 - One
- Electrode Materials:
 - Etched copper
 - Silver
 - Carbon
 - Indium Tin Oxide (ITO)
- Panel Materials:
 - Plastic
 - Glass
 - Composites
 - Painted surfaces (low particle density metallic paints possible)
- Panel Thickness:
 - Up to 10 mm glass (electrode size dependent)
 - Up to 5 mm plastic (electrode size dependent)
- Key Sensitivity:
 - Individually settable via simple commands over serial interface
- Interface:
 - I²C-compatible slave mode (100 kHz). Discrete detection outputs
- Moisture Tolerance:
 - Increased moisture tolerance based on hardware design and firmware tuning
- Signal Processing:
 - Self-calibration
 - auto drift compensation
 - noise filtering
 - Adjacent Key Suppression® (AKS®)
- Applications:
 - Mobile appliances
- Power:
 - 1.8 V to 5.5 V
- Package:
 - 28-pin 4 x 4 mm QFN RoHS compliant IC

1. Pinout and Schematic

1.1 Pinout Configuration

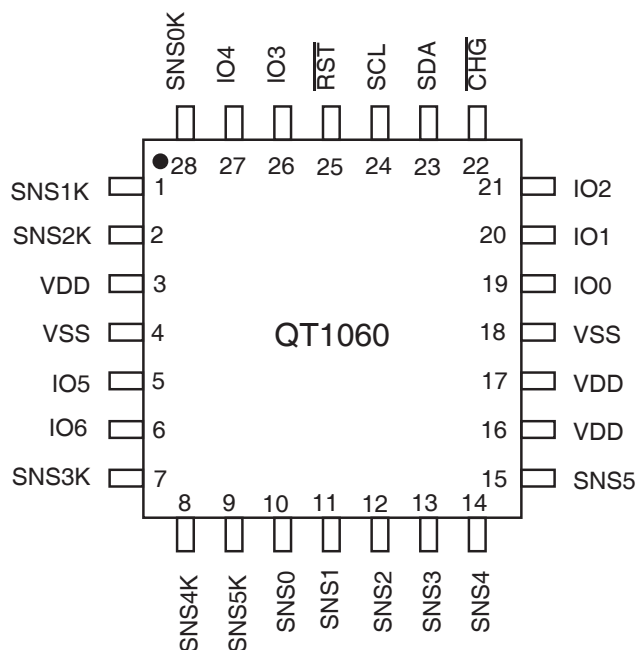

1.2 Pin Descriptions

Table 1-1. Pin Allocation

Pin	Name	Type	Description	If Unused, Connect To...
1	SNS1K	I/O	To Cs capacitor and to key	Leave open
2	SNS2K	I/O	To Cs capacitor and to key	Leave open
3	VDD	P	Positive power pin	
4	VSS	P	Ground power pin	
5	IO5	I/O	I/O Port Pin 5	Leave open and set as output
6	IO6	I/O	I/O Port Pin 6	Leave open and set as output
7	SNS3K	I/O	To Cs capacitor and to key	Leave open
8	SNS4K	I/O	To Cs capacitor and to key	Leave open
9	SNS5K	I/O	To Cs capacitor and to key	Leave open
10	SNS0	I/O	To Cs Capacitor	Leave open
11	SNS1	I/O	To Cs Capacitor	Leave open
12	SNS2	I/O	To Cs Capacitor	Leave open
13	SNS3	I/O	To Cs Capacitor	Leave open

Table 1-1. Pin Allocation (Continued)

Pin	Name	Type	Description	If Unused, Connect To...
14	SNS4	I/O	To Cs Capacitor	Leave open
15	SNS5	I/O	To Cs Capacitor	Leave open
16	VDD	P	Positive power pin	
17	VDD	P	Positive power pin	
18	VSS	P	Ground power pin	
19	IO0	I/O	I/O Port Pin 0	Leave open and set as output
20	IO1	I/O	I/O Port Pin 1	Leave open and set as output
21	IO2	I/O	I/O Port Pin 2	Leave open and set as output
22	$\overline{\text{CHG}}$	OD	Change line	Leave open
23	SDA	OD	I ² C Data line	Resistor to Vdd or Vss only in standalone mode
24	SCL	OD	I ² C Clock Line	Resistor to Vdd or Vdd only in standalone mode
25	$\overline{\text{RST}}$	I	Reset, active low	Vdd
26	IO3	I/O	I/O Port Pin 3	Leave open and set as output
27	IO4	I/O	I/O Port Pin 4	Leave open and set as output
28	SNS0K	I/O	To Cs capacitor and to key	Leave open

I Input only
 OD Open drain output

O Output only, push-pull
 P Ground or power

I/O Input/output

1.3 Schematic

Figure 1-1. Typical Circuit

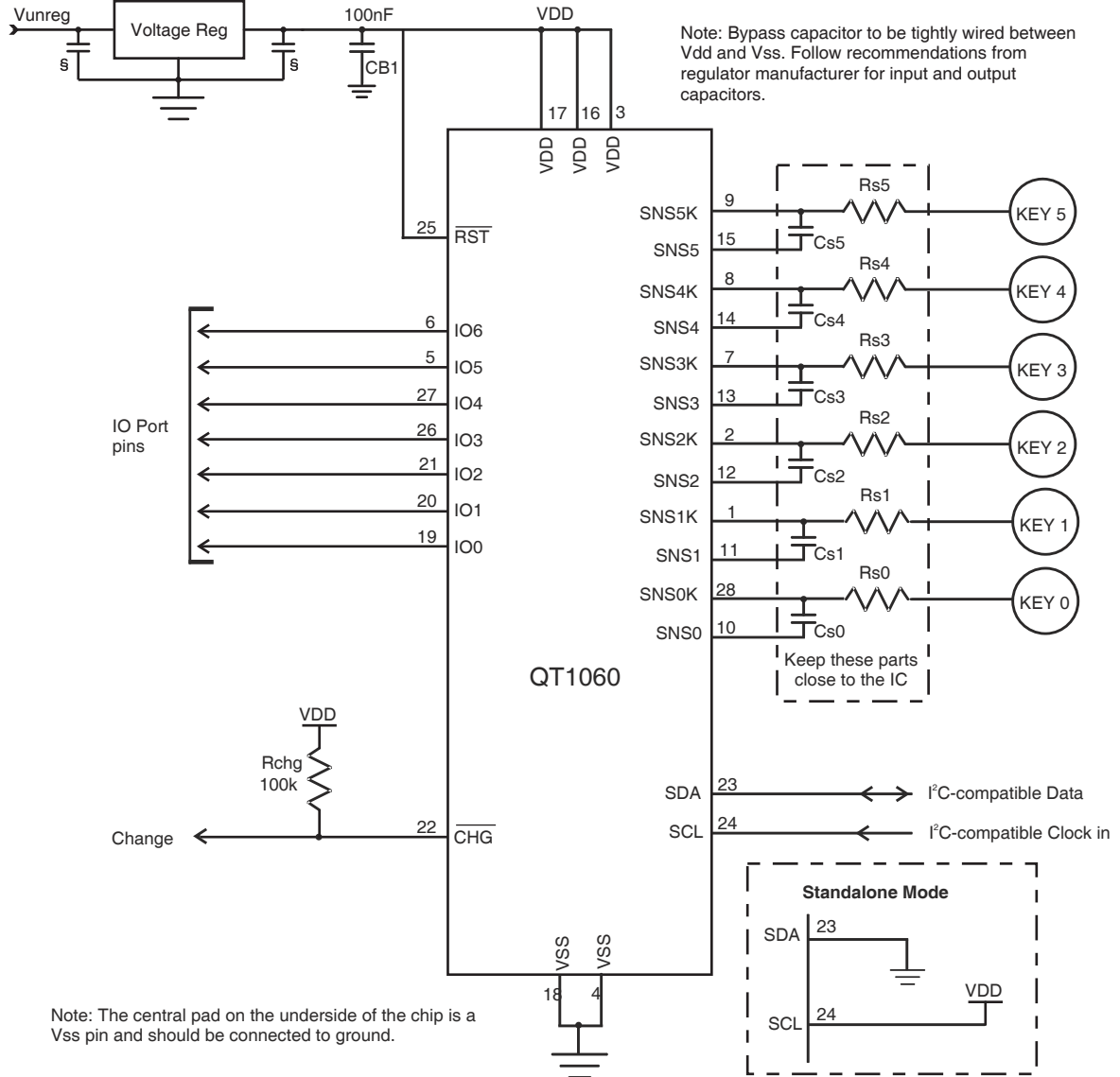

For component values in Figure 1-1 check the following sections:

- [Section 3.1 on page 11](#): Cs capacitors (Cs0 – Cs5)
- [Section 3.2 on page 11](#): Series resistors (Rs0 – Rs5)
- [Section 3.5 on page 12](#): Voltage levels
- [Section 4.4 on page 15](#): SDA, SCL pull-up resistors (not shown)
- [Section 3.3 on page 11](#): LED traces

Suggested regulator manufacturers:

- Torex (XC6215 series)
- Seiko (S817 series)
- BCDSemi (AP2121 series)

2. Overview

2.1 Introduction

The AT42QT1060 (QT1060) is a digital burst mode charge-transfer (QT™) capacitive sensor driver designed specifically for mobile phone applications. The device can sense from two to six keys; up to four keys can be disabled by not installing their respective sense capacitors (Cs). It also has up to seven configurable input/output lines, with Pulse Width Modulation (PWM) for driving LEDs.

This device includes all signal processing functions necessary to provide stable sensing under a wide variety of changing conditions, and the outputs are fully de-bounced. Only a few external parts are required for operation.

The QT1060 modulates its bursts in a spread-spectrum fashion in order to heavily suppress the effects of external noise, and to suppress RF emissions.

2.2 Keys

The QT1060 can have a minimum of two keys and a maximum of six keys. These can be constructed in different shapes and sizes. See [“Features” on page 1](#) for the recommended dimensions.

Unused keys should be disabled by removing the corresponding Cs and Rs components and connecting the SNS pins as shown in the *If Unused* column of [Table on page 2](#). The unused keys are always pared from the burst sequence in order to optimize speed. See [Section 6. on page 25](#) about setting up the keys.

2.3 Standalone Mode

The QT1060 can operate in a standalone mode where an I²C-compatible interface is not required. To enter standalone mode, connect SDA to Vss and SCL to Vdd before powering up the QT1060.

In standalone mode the default start-up values are used except for the I/O mask (Address 23). The I/O mask is configured so that all the I/Os are outputs (I/O mask = 0x7F). This means that key detection is reported via the respective I/Os.

2.4 I/O Lines

2.4.1 Overview

There is an input/output (I/O) port consisting of seven lines that can be individually programmed as inputs or outputs. They can be either a digital type or PWM. The PWM level can be set to 256 possible values and is common to all lines.

The I/O lines are normally initialized as inputs. However, if an I²C interface is not used and the SDA and SCL pins are connected to Vss and Vdd respectively, then the I/O lines are initialized as outputs (see [Section 2.3](#)).

The outputs can also be linked to either the detection channels or the output register to allow the outputs to be either user controlled or to indicate detection. These options can be set in the pin control masks (see [Table on page 16](#)).

Unused I/O lines should be disabled by connecting as shown in the *If Unused* column of [Table 1-1 on page 2](#). See [Section 6. on page 25](#) about setting up the I/O lines.

2.4.2 I/O Mask

A 1 in any bit position of this mask sets the corresponding pin to an output. If a bit is 0, the pin is an input and the function of the PWM, detect and active state masks will not matter for this pin. The level of the input pins is reflected in the input Status register. Changes to the logic levels on the inputs cause the $\overline{\text{CHG}}$ line to be asserted.

2.4.3 PWM Mask

A 1 in any bit position in this mask sets the corresponding pin to operate in PWM mode when its user output buffer is active and configured as an output. A zero sets the pin in digital mode. The PWM value is set in the PWM register that is writable via I²C communication.

2.4.4 Detection Mask

A 1 in any bit position in this mask sets the corresponding pin to be controlled by the status register. If the pin is configured as an output, it is asserted automatically if there is a detection on the corresponding sensor channel. A zero in any bit sets the pin to be controlled by the user output buffer, allowing the user to control the pins directly.

2.4.5 Active Level Mask

A 1 in any bit position in this mask sets the corresponding pin to be active high if configured as an output. A zero sets the pin to be active low.

2.5 Acquisition/Low Power Modes (LP)

There are several different acquisition modes. These are controlled via the Low Power (LP) mode byte (see [Section 5.12 on page 20](#)) which can be written to via I²C communication.

LP mode controls the intervals between acquisition measurements. Longer intervals consume lower power but have increased response time. During calibration and during the detect integrator (DI) period, the LP mode is temporarily set to LP mode 1 for a faster response.

The QT1060 operation is based on a fixed cycle time of approximately 16 ms. The LP mode setting indicates how many of these periods exist per measurement cycle. For example, if LP mode = 1, there is an acquisition every cycle (16 ms). If LP mode = 3, there is an acquisition every 3 cycles (48 ms), and so on.

SLEEP mode (LP mode = 0) is available for minimum current drain. In this mode, the device is inactive, with the device status being held as it was before going to sleep, and no measurements are carried out.

LP settings above mode 32 (512 ms) result in slower thermal drift compensation and should be avoided in applications where fast thermal transients occur.

If LP mode = 255 the device operates in Free-run mode. In this mode the device will not enter LP mode between measurements. The device continuously performs measurements one after another, resulting in the fastest response time but the highest power consumption.

2.6 Adjacent Key Suppression (AKS) Technology

The device includes the Atmel-patented Adjacent Key Suppression technology, to allow the use of tightly spaced keys on a keypad with no loss of selectability by the user.

There can be one AKS group, implemented so that only one key in the group may be reported as being touched at any one time. A key with a higher delta signal dominates and pushes a key with a smaller delta out of detect. This allows a user to slide a finger across multiple keys with only the dominant key reporting touch.

The keys which are members of the AKS group can be set via the AKS mask (see [Section 5.15 on page 21](#)). Keys outside the group may be in detect simultaneously.

For maximum flexibility there is no automatic key recalibration timeout on key detection. The user should issue a recalibration command if the key has been in detect for too long, for example for more than 30 seconds (see [Figure 2.10](#)).

2.7 Change Line

The Change line (see $\overline{\text{CHG}}$ in [Figure 1-1 on page 4](#)) signals when there is a change in state in the Detection or Input status bytes and is active low. It is cleared (allowed to float high) when the host reads the status bytes.

If the status bytes change back to their original state before the host has read the status bytes (for example, a touch followed by a release), the $\overline{\text{CHG}}$ line will be held low. In this case, a read to any memory location will clear the $\overline{\text{CHG}}$ line.

The $\overline{\text{CHG}}$ line is open-drain and should be connected via a 100k Ω resistor to Vdd. It is necessary for minimum power operation as it ensures that the QT1060 can sleep for as long as possible. Communications wake up the QT1060 from sleep causing a higher power consumption if the part is randomly polled.

The keys enabled by the key bit mask or a change in the Input port status cause a key change interrupt (see [Table 5-1 on page 16](#)). Create a guard channel by removing that key from the key mask and including it in the AKS mask. Touching the guard channel does not cause an interrupt. The key and AKS masks are set by using the mask commands (see [Table 5-1](#)).

2.8 Types of Reset

2.8.1 External Reset

An external reset logic line can be used if desired, fed into the $\overline{\text{RST}}$ pin. However, under most conditions it is acceptable to tie $\overline{\text{RST}}$ to Vdd.

2.8.2 Soft Reset

The host can cause a device reset by writing a nonzero value to the reset byte. This soft reset triggers the internal watchdog timer on a ~16 ms interval.

- After ~16 ms the device resets and wakes again.
- After a further 30 ms initialization period the device begins responding to its I²C slave address.
- After another ~80 ms the device asserts the $\overline{\text{CHG}}$ line to indicate it is ready for touch sensing.

The device NACKs any attempts to communicate with it during the first 30 ms of its initialization period.

After $\overline{\text{CHG}}$ goes low, the device calibrates the sensing channels. When complete, the $\overline{\text{CHG}}$ pin is set low once again.

2.9 Moisture Tolerance

The presence of water (condensation, sweat, spilt water, and so on) on a sensor can alter the signal values measured and thereby affect the performance of any capacitive device. The moisture tolerance of QTouch devices can be improved by designing the hardware and fine-tuning the firmware following the recommendations in the application note *Atmel AVR3002: Moisture Tolerant QTouch Design* (www.atmel.com/images/doc42017.pdf).

2.10 Calibration

The command byte can force a recalibration at any time by writing a nonzero value to the calibration byte. This can be useful to clear out a stuck key condition after a prolonged period of uninterrupted detection.

When the device recalibrates, it also autosenses which keys are enabled by examining the burst length of each electrode. If the burst length is either too short (if there is a missing or open Cs capacitor) or too long (a Cs capacitor is shorted), the key is ignored until the next calibration.

The count of the number of currently enabled keys is found in the status response byte. This number can change after a CAL command; for example, if a Cs capacitor is intermittent.

2.11 Guard Channel

The device has a guard channel option, which allows any key, or combination of keys, to be configured as a guard channel to help prevent false detection. Guard channel keys should be more sensitive than the other keys (physically bigger or larger Cs), subject to burst length limitations (see [Section 2.12.3](#)).

With guard channel enabled, the designated key(s) is connected to a sensor pad which detects the presence of touch and overrides any output from the other keys using the chip AKS feature. The guard channel option is enabled by an I²C command.

To enable a guard channel the relevant key should be removed from the key mask (see [Table 5-1 on page 16](#)). In addition, the guard channel needs to be included within the AKS mask with the other keys for the guard function to operate. Note that a detection on the guard channel does not cause a change request.

With the guard channel not enabled, all the keys work normally.

Figure 2-1. Guard Channel Example

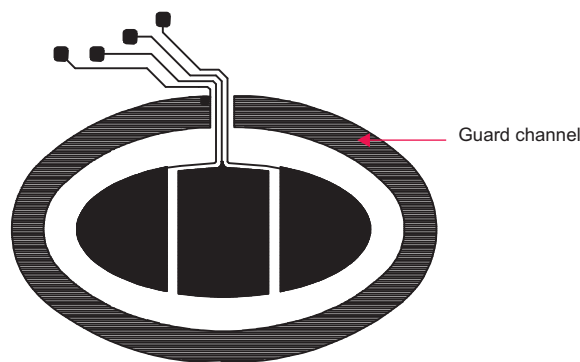

2.12 Signal Processing

2.12.1 Detect Threshold

The device detects a touch when the signal has crossed a threshold level and remained there for a specified number of counts (see [Section 5.11 on page 19](#)). This can be altered on a key-by-key basis using the key threshold I²C commands.

2.12.2 Detect Integrator

The device features a fast detection integrator counter (DI filter), which acts to filter out noise at the small expense of slower response time. The DI filter requires a programmable number of consecutive samples confirmed in detection before the key is declared to be touched. There is also a fast DI on the end of the detection (see [Section 5.20 on page 23](#)). The fast DI will not be applied at the start of a detection if a detection on any other channel has already been declared.

2.12.3 Burst Length Limitations

In a balanced system common signals are regarded as thermal shifts and are removed by the relative referencing drifting, if enabled. This means that the burst lengths must be similar. This can be checked by reading the reference values (Address 52 – 63) and making sure that they are similar. The absolute maximum difference is that the maximum value of reference is less than three times the minimum value amongst all the channels. It is recommended having the burst lengths (references) as close together as possible, through better routing and layout.

For example, if the keys have references of 250, 230, 220, 240, 200 and 210, this is acceptable. If the keys have references of 250, 230, 220, 240, 200 and 710, the efficiency of the relative referencing drifting will be affected. The last key's (710) layout should be changed or relative referencing be disabled. The closer the references are in value, the better the relative referencing drifting performs.

If only normal drifting is enabled, the burst lengths can have bigger variations.

The normal operating limit of burst lengths is between 16 and 1536 counts. A value out of these limits causes the respective key to be disabled and not measured until a calibration. Signal value for an out-of-limit key is zero.

3. Wiring and Parts

3.1 Cs Sample Capacitors

Cs0 – Cs5 are the charge sensing sample capacitors; normally they are identical in nominal value. The optimal Cs values depend on the thickness of the panel and its dielectric constant. Thicker panels require larger values of Cs. Typical values are 2.2 nF to 10 nF.

The value of Cs should be chosen so that a light touch on a key produces a reduction of ~10 – 20 in the key signal value (see [Section 5.22 on page 23](#)). The chosen Cs value should never be so large that the key signals exceed ~1000, as reported by the chip in the debug data.

The Cs capacitors must be X7R or PPS film type, for stability. For consistent sensitivity, they should have a 10% tolerance. A 20% tolerance may cause small differences in sensitivity from key to key and unit to unit. If a channel is not used, the Cs capacitor may be omitted.

3.2 Rs Resistors

Series resistors Rs (Rs0 – Rs5) are inline with the electrode connections and should be used to limit electrostatic discharge (ESD) currents and to suppress radio frequency (RF) interference. They should be approximately 4.7 k Ω to 20 k Ω each.

Although these resistors may be omitted, the device may become susceptible to external noise or radio frequency interference (RFI). For details of how to select these resistors see the Application Note QTAN0002, *Secrets of a Successful QTouch Design*, downloadable from the Touch Technology area of the Atmel website, www.atmel.com.

3.3 LED Traces and Other Switching Signals

Digital switching signals near the sense lines induce transients into the acquired signals, deteriorating the SNR performance of the device. Such signals should be routed away from the sensing traces and electrodes, or the design should be such that these lines are not switched during the course of signal acquisition (bursts).

LED terminals which are multiplexed or switched into a floating state, and which are within, or physically very near, a key (even if on another nearby PCB) should be bypassed to either Vss or Vdd with at least a 10 nF capacitor. This is to suppress capacitive coupling effects which can induce false signal shifts. The bypass capacitor does not need to be next to the LED, in fact it can be quite distant. The bypass capacitor is noncritical and can be of any type.

LED terminals which are constantly connected to Vss or Vdd do not need further bypassing.

3.4 PCB Cleanliness

Modern no-clean flux is generally compatible with capacitive sensing circuits.



CAUTION: If a PCB is reworked to correct soldering faults relating to the device, or to any associated traces or components, be sure that you fully understand the nature of the flux used during the rework process. Leakage currents from hygroscopic ionic residues can stop capacitive sensors from functioning. If you have any doubts, a thorough cleaning after rework may be the only safe option.

If a PCB is reworked in any way, clean it thoroughly to remove all traces of the flux residue around the capacitive sensor components. Dry it thoroughly before any further testing is conducted.

3.5 Power Supply

See [Section 7.2 on page 26](#) for the power supply range. If the power supply fluctuates slowly with temperature, the device tracks and compensates for these changes automatically with only minor changes in sensitivity. If the supply voltage drifts or shifts quickly, the drift compensation mechanism is not able to keep up, causing sensitivity anomalies or false detections.

The usual power supply considerations with QT parts apply to the device. The power should be clean and come from a separate regulator if possible. However, this device is designed to minimize the effects of unstable power, and except in extreme conditions should not require a separate Low Dropout (LDO) regulator.

See underneath [Figure 1-1 on page 4](#) for suggested regulator manufacturers.



Caution: A regulator IC shared with other logic can result in erratic operation and is **not** advised.

A single ceramic 0.1 μF bypass capacitor, with short traces, should be placed very close to the power pins of the IC. Failure to do so can result in device oscillation, high current consumption, erratic operation, and so on.

It is assumed that a larger bypass capacitor ($\sim 1 \mu\text{F}$) is somewhere else in the power circuit; for example, near the regulator.

To assist with transient regulator stability problems, the QT1060 waits 500 μs any time it wakes up from a sleep state (that is, in SLEEP and LP modes) before acquiring, to allow V_{DD} to fully stabilize.

3.6 Bus Specification

Table 3-1. I²C Bus Specification

Parameter	Unit
Address space	7-bit
Maximum bus speed (SCL)	100 kHz
Hold time START condition	4 μs minimum
Setup time for STOP condition	4 μs minimum
Bus free time between a STOP and START condition	4.7 μs minimum
Rise times on SDA and SCL	1 μs maximum

4. I²C Communications

4.1 I²C Protocol

4.1.1 Protocol

The I²C protocol is based around access to an address table (see [Table 5-1 on page 16](#)) and supports multibyte reads and writes. The maximum clock rate is 100 kHz.

4.1.2 Signals

The I²C interface requires two signals to operate:

- **SDA** - Serial Data
- **SCL** - Serial Clock

A third line, $\overline{\text{CHG}}$, is used to signal when the device has seen a change in the status byte:

- **CHG**: Open-drain, active low when any capacitive key in the key mask has changed state or any input line has changed state since the last I²C read. After reading the two status bytes, this pin floats (high) again if it is pulled up with an external resistor. If the status bytes change back to their original state before the host has read the status bytes (for example, a touch followed by a release), the $\overline{\text{CHG}}$ line will be held low. In this case, a read to any memory location will clear the $\overline{\text{CHG}}$ line.

4.1.3 Clock Stretching

The device has an internal monitor that resets its I²C hardware if either I²C-compatible line is held low, without the other line changing, for more than about 14 ms. It is important that no other device on the bus clock stretches for 14 ms, otherwise the monitor will reset the I²C hardware and transfers with the chip may be corrupted.

If the device is configured to run in stand-alone mode, the monitor will be turned off.

4.2 I²C Address

There is one preset I²C address of 0x12. This is not changeable.

4.3 Data Read/Write

4.3.1 Writing Data to the Device

The sequence of events required to write data to the device is shown next

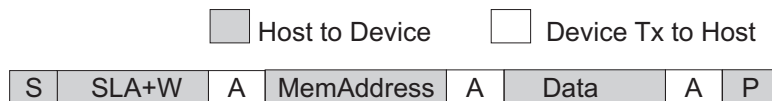

Table 4-1. Description of Write Data Bits

Key	Description
S	Start condition
SLA+W	Slave address plus write bit
A	Acknowledge bit
MemAddress	Target memory address within device
Data	Data to be written
P	Stop condition

1. The host initiates the transfer by sending the START condition
2. The host follows this by sending the slave address of the device together with the WRITE bit.
3. The device sends an ACK.
4. The host then sends the memory address within the device it wishes to write to.
5. The device sends an ACK.
6. The host transmits one or more data bytes; each is acknowledged by the device.
7. If the host sends more than one data byte, they are written to consecutive memory addresses.
8. The device automatically increments the target memory address after writing each data byte.
9. After writing the last data byte, the host should send the STOP condition.

Note: the host should not try to write beyond address 255 because this is the limit of the device's internal memory address.

4.3.2 Reading Data From the Device

The sequence of events required to read data from the device is shown next.

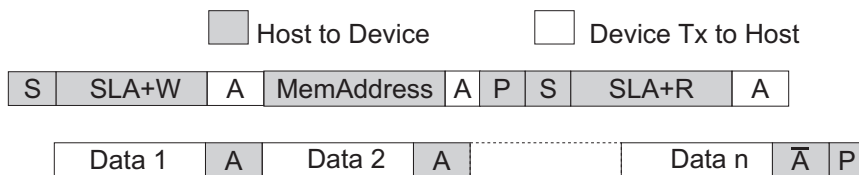

1. The host initiates the transfer by sending the START condition
2. The host follows this by sending the slave address of the device together with the WRITE bit.
3. The device sends an ACK.
4. The host then sends the memory address within the device it wishes to read from.
5. The device sends an ACK.

6. The host must then send a STOP and a START condition followed by the slave address again but this time accompanied by the READ bit.
7. The device returns an ACK, followed by a data byte.
8. The host must return either an ACK or NACK.
 1. If the host returns an ACK, the device subsequently transmits the data byte from the next address. Each time a data byte is transmitted, the device automatically increments the internal address. The device continues to return data bytes until the host responds with a NACK.
 2. If the host returns a NACK, it should then terminate the transfer by issuing the STOP condition.
9. The device resets the internal address to the location indicated by the memory address sent to it previously. Therefore, there is no need to send the memory address again when reading from the same location.

4.4 SDA, SCL

The I²C bus transmits data and clock with SDA and SCL respectively. They are open-drain; that is I²C master and slave devices can only drive these lines low or leave them open. The termination resistors (not shown) pull the line up to V_{dd} if no I²C-compatible device is pulling it down.

The termination resistors commonly range from 1 k Ω to 10 k Ω and should be chosen so that the rise times on SDA and SCL meet the I²C specifications (1 μ s maximum).

Standalone mode: if I²C-compatible communications are not required, then standalone mode can be enabled by connecting SDA to V_{ss} and SCL to V_{dd}. See [Section 2.3 on page 6](#) for more information.

5. Setups

5.1 Introduction

The device calibrates and processes signals using a number of algorithms specifically designed to provide for high survivability in the face of adverse environmental challenges. User-defined Setups are employed to alter these algorithms to suit each application. These Setups are loaded into the device over the I²C serial interfaces.

Table 5-1. Internal Register Address Allocation

Address	Use	R/W	Bit 7	Bit 6	Bit 5	Bit 4	Bit 3	Bit 2	Bit 1	Bit 0
0	Chip ID	R	Major ID (= 3)				Minor ID (= 1)			
1	Version	R	Device version number							
2	Minor version	R	Minor version number							
3	Reserved		Reserved							
4	Detection status	R	Calibrating	Res	Key5	Key4	Key3	Key2	Key1	Key0
5	Input port status	R	Res	Input 6	Input 5	Input 4	Input 3	Input 2	Input 1	Input 0
6 – 11	Reserved		Reserved							
12	Calibrate	R/W	Writing a nonzero value forces a calibration							
13	Reset	R/W	Writing a nonzero value forces a reset							
14	Drift Option	R/W	Res	Res	Res	Res	Res	Res	Res	DRIFT
15	Positive Recalibration Delay	R/W	MSB							LSB
16	NTHR key 0	R/W	MSB							LSB
17	NTHR key 1	R/W	MSB							LSB
18	NTHR key 2	R/W	MSB							LSB
19	NTHR key 3	R/W	MSB							LSB
20	NTHR key 4	R/W	MSB							LSB
21	NTHR key 5	R/W	MSB							LSB
22	LP mode	R/W	MSB							LSB
23	I/O mask	R/W	MSB	IO6	IO5	IO4	IO3	IO2	IO1	IO0
24	Key mask	R/W	CAL	Res	Key 5	Key 4	Key 3	Key 2	Key 1	Key 0
25	AKS mask	R/W	Res	Res	Key 5	Key 4	Key 3	Key 2	Key 1	Key 0
26	PWM mask	R/W	Res	IO6	IO5	IO4	IO3	IO2	IO1	IO0
27	Detection mask	R/W	Res	IO6	IO5	IO4	IO3	IO2	IO1	IO0
28	Active level mask	R/W	Res	IO6	IO5	IO4	IO3	IO2	IO1	IO0
29	User output buffer	R/W	Res	IO6	IO5	IO4	IO3	IO2	IO1	IO0
30	DI	R/W	MSB							LSB
31	PWM level	R/W	MSB							LSB

Table 5-1. Internal Register Address Allocation (Continued)

Address	Use	R/W	Bit 7	Bit 6	Bit 5	Bit 4	Bit 3	Bit 2	Bit 1	Bit 0
32 – 39	Reserved		Reserved							
40 – 51	Key 0 – 5 Signal	R								
52 – 63	Key 0 – 5 Reference	R								
Note: Res = Reserved; only write zero to these bits.										

5.2 Address 0: Chip ID

Table 5-2. Chip ID

Address	b7	b6	b5	b4	b3	b2	b1	b0
0	MAJOR ID				MINOR ID			

MAJOR ID: Reads back as 3

MINOR ID: Reads back as 1

5.3 Address 1: Device Version Number

Table 5-3. Device Version Number

Address	b7	b6	b5	b4	b3	b2	b1	b0
1	DEVICE VERSION NUMBER							

DEVICE VERSION NUMBER: this is the 8-bit firmware version number (0x03).

5.4 Address 2: Minor Version Number

Table 5-4. Minor Version Number

Address	b7	b6	b5	b4	b3	b2	b1	b0
2	MINOR VERSION NUMBER							

MINOR VERSION NUMBER: this is the 8-bit minor firmware revision number (0x00).

5.5 Address 4: Detection Status

Table 5-5. Detection Status

Address	b7	b6	b5	b4	b3	b2	b1	b0
4	CAL	Reserved	KEY5	KEY4	KEY3	KEY2	KEY1	KEY0

CAL: a 1 indicates that the QT1060 is currently calibrating.

KEY0 – 5: bits 0 to 5 indicate which keys are in detection, if any; touched keys report as 1, untouched or disabled keys report as 0.

5.6 Address 5: Input Port Status

Table 5-6. Input Port Status

Address	b7	b6	b5	b4	b3	b2	b1	b0
5	Reserved	INPUT 6	INPUT 5	INPUT 4	INPUT 3	INPUT 2	INPUT 1	INPUT 0

INPUT 0 – 6: these bits indicate the state of the I/O lines that are configured as inputs; 1 indicating logic 1 on the input, 0 indicating logic 0. The bits corresponding to any keys configured as outputs read as 0.

5.7 Address 12: Calibrate

Table 5-7. Calibrate

Address	b7	b6	b5	b4	b3	b2	b1	b0
12	Writing a nonzero value forces a calibration							

Writing any nonzero value into this address triggers the device to start a calibration cycle. The CAL flag in the status register is set when begun and cleared when the calibration has finished.

5.8 Address 13: Reset

Table 5-8. Reset

Address	b7	b6	b5	b4	b3	b2	b1	b0
13	Writing a nonzero value forces a reset							

Writing any nonzero value to this address triggers the device to reset.

5.9 Address 14: Drift Option

Table 5-9. Drift Option

Address	b7	b6	b5	b4	b3	b2	b1	b0
14	Reserved							DRIFT

DRIFT: there are two types of drift option: normal and relative referencing.

If DRIFT = 0, relative referencing and normal drift are enabled.

If DRIFT = 1, only normal drift is enabled.

Relative referencing compensates for fast signal drifts that are common to all keys. This mode is suitable if the keys are placed close to each other and have closely matched burst lengths (see [Section 2.12.3 on page 9](#)). Normal drifting is also carried out but at a slower rate compared to the relative referencing drift rate.

Default: 1 (relative referencing Off)

5.10 Address 15: Positive Recalibration Delay

Table 5-10. Positive Recalibration Delay

Address	b7	b6	b5	b4	b3	b2	b1	b0
15	POSITIVE RECALIBRATION DELAY							

POSITIVE RECALIBRATION DELAY: If any key is found to have a significant drop in capacitance, that is, an “away from touch” signal, then this is deemed to be an error condition. If this condition persists for more than the Positive Recalibration Delay (PRD) period, then an automatic recalibration is carried out on all keys.

The condition that the error is triggered on depends on the drift compensation mode. If relative referencing drifting is enabled (DRIFT = 0), then an “away from touch” delta of more than four counts triggers the error. If only normal mode drifting is enabled (DRIFT = 1), then an “away from touch” delta of more than 75% of the NTHR triggers the error.

In LP mode the Positive Recalibration Delay is the PRD value multiplied by 16 ms cycle time; in Free Run Mode the Positive Recalibration delay is the PRD value multiplied by the minimum cycle time (~7 ms, but depends on Cs and design).

Default: 40 (40 × 16 ms = 640 ms; default LP is 32 ms)

5.11 Address 16 – 21: NTHR Keys 0 – 5

Table 5-11. NTHR Keys 0 – 5

Address	b7	b6	b5	b4	b3	b2	b1	b0
16 – 21	MSB							LSB

NTHR Keys 0 – 5: these 8-bit values set the threshold value for each key to register a detection.

Default: 10 counts

5.12 Address 22: LP Mode

Table 5-12. LP Mode

Address	b7	b6	b5	b4	b3	b2	b1	b0
22	MSB							LSB

LP Mode: this 8-bit value determines the number of 16 ms intervals between key measurements. Longer intervals between measurements yield lower power consumption at the expense of slower response to touch.

LP7 – 0	Mode
0	SLEEP
1	16 ms
2	32 ms
3	48 ms
4	64 ms
...	...
254	4.064 s
255	Free-run

A value of zero causes the device to enter SLEEP mode where no measurements are performed.

A value of 255 causes the device to enter Free-run mode where measurements are continuously performed without entering a low power mode between measurements. This provides the fastest response time but also the highest power consumption.

Default: 2 (32 ms between key acquisitions)

5.13 Address 23: I/O Mask

Table 5-13. I/O Mask

Address	b7	b6	b5	b4	b3	b2	b1	b0
23	Reserved	IO6	IO5	IO4	IO3	IO2	IO1	IO0

IO0 – IO6: these bits control the direction of the I/O pins. A 1 sets the pin as an output, a 0 as an input. See [Section 5.24 on page 24](#) for I/O register precedence and example usage.

Default: 0 (all I/Os are set as inputs, when using the I²C-compatible mode)
(all I/Os are set as outputs (0x7F), when using the standalone mode)

5.14 Address 24: Key Mask

Table 5-14. Key Mask

Address	b7	b6	b5	b4	b3	b2	b1	b0
24	CAL	Reserved	KEY5	KEY4	KEY3	KEY2	KEY1	KEY0

CAL: this bit controls whether the CAL bit causes a $\overline{\text{CHG}}$ transition.

KEY0 – 5 (Key Mask): these bits control whether a change in the corresponding bit in the detection status register generates a transition on the $\overline{\text{CHG}}$ line. A 1 allows the status bit to cause a $\overline{\text{CHG}}$ request, a 0 stops the corresponding bit from causing a $\overline{\text{CHG}}$ request.

Default: 0xBF (all bits create a $\overline{\text{CHG}}$ request)

5.15 Address 25: AKS Mask

Table 5-15. AKS Mask

Address	b7	b6	b5	b4	b3	b2	b1	b0
25	Reserved	Reserved	KEY5	KEY4	KEY3	KEY2	KEY1	KEY0

KEY0 – 5 (AKS Mask): these bits control which keys are included in the AKS group. A 1 means the corresponding key is included in the AKS group and may only go into detect when it has the largest signal change of any key in the group. A 0 means that it is excluded and can go into detect whenever its threshold is passed.

Default: 0x00 (no keys are within the AKS group)

5.16 Address 26: PWM Mask

Table 5-16. PWM Mask

Address	b7	b6	b5	b4	b3	b2	b1	b0
26	Reserved	I/O6	I/O5	I/O4	I/O3	I/O2	I/O1	I/O0

I/O0 – 6 (PWM Mask): these bits control which I/Os that are configured as outputs, and its user output buffer activated, will output a PWM signal. A 1 means the output generates a PWM signal, a 0 means the output generates a logic level. The active level of the output (both logical and PWM) is determined by the Active level mask. See [Section 5.24 on page 24](#) for I/O register precedence and example usage.

Default: 0x00 (PWM is off on all I/Os)

5.17 Address 27: Detection Mask

Table 5-17. Detection Mask

Address	b7	b6	b5	b4	b3	b2	b1	b0
27	Reserved	I/O6	I/O5	I/O4	I/O3	I/O2	I/O1	I/O0

I/O0 – 6 (Detection Mask): these bits control which I/Os that are configured as outputs will be controlled by their corresponding capacitive key. A 1 means the output n generates an active output when key n is detecting a touch. A 0 means that the output is controlled by the output buffer. See [Section 5.24 on page 24](#) for I/O register precedence and example usage.

Default: 0x3F (all I/Os are controlled by key status)

5.18 Address 28: Active Level Mask

Table 5-18. Active Level Mask

Address	b7	b6	b5	b4	b3	b2	b1	b0
28	Reserved	I/O6	I/O5	I/O4	I/O3	I/O2	I/O1	I/O0

I/O0 – 6 (Active Level Mask): these bits control the active logic level for the I/Os that are configured as outputs. A 1 means the output generates an active high output, a 0 means that the output is active low. See [Section 5.24](#) for I/O register precedence and example usage.

Default: 0 (all I/Os are active low output)

5.19 Address 29: User Output Buffer

Table 5-19. User Output Buffer

Address	b7	b6	b5	b4	b3	b2	b1	b0
29	Reserved	I/O6	I/O5	I/O4	I/O3	I/O2	I/O1	I/O0

I/O0 – 6 (User Output Buffer): these bits control the output level for the I/Os that are configured as outputs. A 1 means the output generates an active output, a 0 means that the output is inactive. See [Section 5.24 on page 24](#) for I/O register precedence and example usage.

Default: 0 (all I/Os inactive)

5.20 Address 30: Detection Integrator

Table 5-20. Detection Integrator

Address	b7	b6	b5	b4	b3	b2	b1	b0
30	MSB	DETECTION INTEGRATOR						LSB

DETECTION INTEGRATOR: this 8-bit value controls the number of consecutive measurements that must be confirmed as having passed the key threshold before that key is registered as being in detect. A value of zero should not be used.

Default: 3

5.21 Address 31: PWM Level

Table 5-21. PWM Level

Address	b7	b6	b5	b4	b3	b2	b1	b0
31	MSB	PWM LEVEL						LSB

PWM LEVEL: this 8-bit value controls the duty cycle of the PWM output signal. Valid values are between 0...255. There is a constant level band at either end of the range, so:

- A value of 0...10 gives a 100% low output
- A value of 250...255 gives a 100% high output

Default: 128 (50:50 duty cycle)

5.22 Address 40 – 51: Key Signal

Table 5-22. Key Signal

Address	b7	b6	b5	b4	b3	b2	b1	b0
40	LSB OF KEY SIGNAL FOR KEY 0							
41	MSB OF KEY SIGNAL FOR KEY 0							
42 – 51	LSB/MSB OF KEY SIGNAL FOR KEYS 1 – 5							

KEY SIGNAL: addresses 40 – 51 allow key signals to be read for each key, starting with key 0. There are two bytes of data for each key. These are the key's 16-bit key signals which are accessed as two 8-bit bytes, stored LSB first. These addresses are read-only.

5.23 Address 52 – 63: Reference Data

Table 5-23. Reference Data

Address	b7	b6	b5	b4	b3	b2	b1	b0
52	LSB OF REFERENCE DATA FOR KEY 0							
53	MSB OF REFERENCE DATA FOR KEY 0							
54 – 63	LSB/MSB OF REFERENCE DATA FOR KEYS 1 – 5							

REFERENCE DATA: addresses 52 – 63 allow reference data to be read for each key, starting with key 0. There are two bytes of data for each key. These are the key's 16-bit reference data which is accessed as two 8-bit bytes, stored LSB first. These addresses are read-only.

5.24 Mask Precedence

Table 5-24 gives the order of priority for the settings in the mask inputs/outputs. The settings in the left-most column have the highest priority, those in the second-left have the next priority, and so on. If two or more settings are incompatible then the setting in the left-hand column overrides the other. The right-most column, *I/O Function*, specifies the expected result.

Table 5-24. Input/Output Mask Precedence

I/O Mask (bit n)	Detection Mask (bit n)	PWM Mask (bit n)	Active Level Mask (bit n)	User Reg (bit n)	QTouch Key (channel n)	I/O Function (I/O n)
0	X	X	X	X	X	Digital Input
1	0	0	0	0	X	Output - Vdd
1	0	0	0	1	X	Output - 0 V
1	0	0	1	0	X	Output - 0 V
1	0	0	1	1	X	Output - Vdd
1	0	1	0	0	X	Output - Vdd
1	0	1	0	1	X	PWM Output
1	0	1	1	0	X	Output - 0 V
1	0	1	1	1	X	PWM Output
1	1	0	0	X	Untouched	Output - Vdd
1	1	0	0	X	Touched	Output - 0 V
1	1	0	1	X	Untouched	Output - 0 V
1	1	0	1	X	Touched	Output - Vdd
1	1	1	0	X	Untouched	Output - Vdd
1	1	1	0	X	Touched	PWM Output
1	1	1	1	X	Untouched	Output - 0 V
1	1	1	1	X	Touched	PWM Output

Note: X = don't care (can be a 1 or a 0)

6. Setting Up Procedures

To Set Up Keys

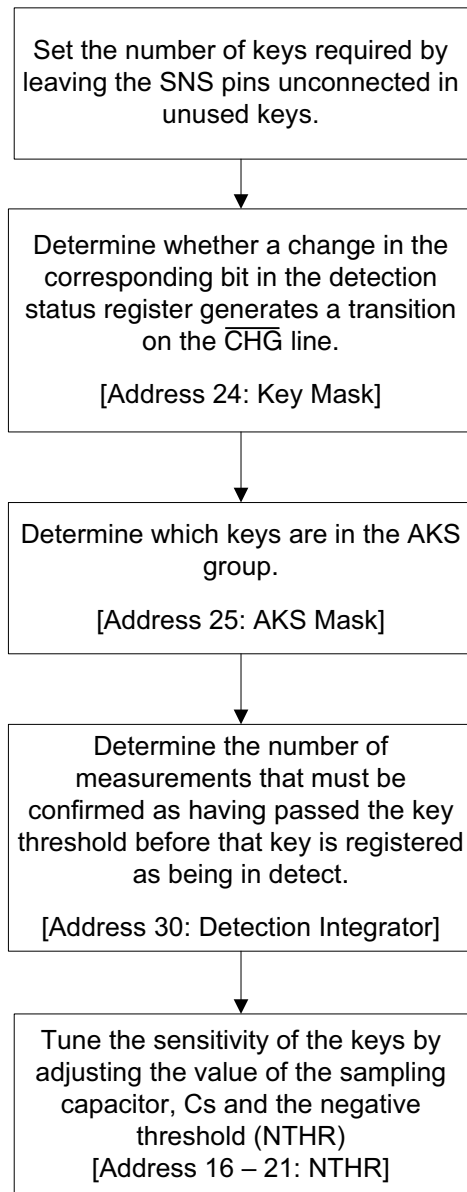

To Set Up I/O Lines

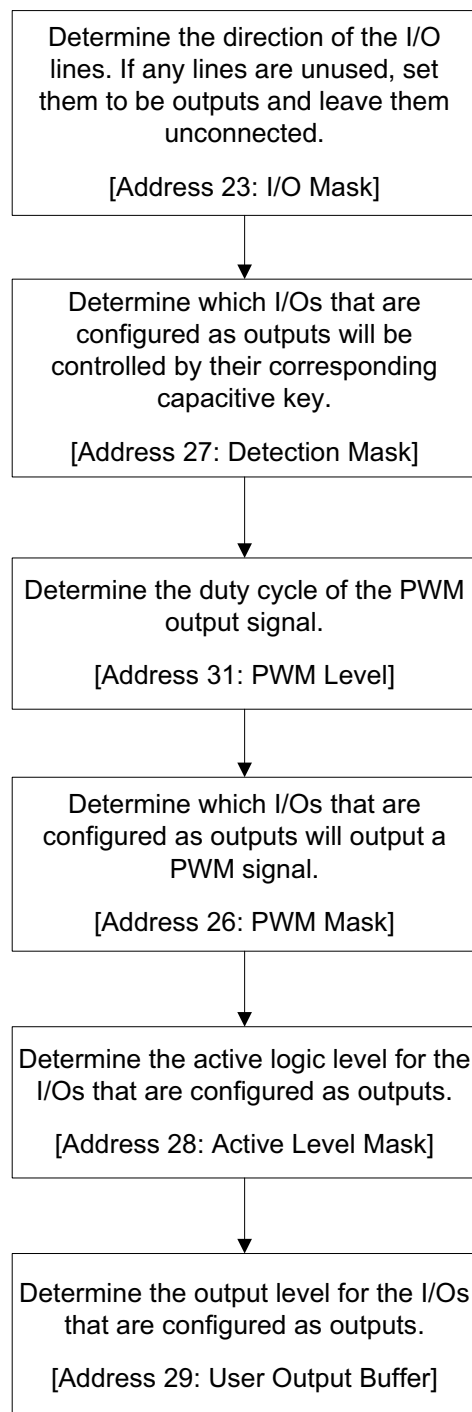

7. Specifications

7.1 Absolute Maximum Specifications

Vdd	–0.5 to +6 V
Max continuous pin current, any control or drive pin	±10 mA
Short circuit duration to ground, any pin	infinite
Short circuit duration to Vdd, any pin	infinite
Voltage forced onto any pin	–0.6 V to (Vdd + 0.6) V

CAUTION: Stresses beyond those listed under *Absolute Maximum Specifications* may cause permanent damage to the device. This is a stress rating only and functional operation of the device at these or other conditions beyond those indicated in the operational sections of this specification is not implied. Exposure to absolute maximum specification conditions for extended periods may affect device reliability.

7.2 Recommended Operating Conditions

Operating temp	–40°C to +85°C
Storage temp	–55°C to +125°C
Vdd	+1.8 V to 5.5 V
Supply ripple+noise	±25 mV
Cx load capacitance per key	2 – 20 pF

7.3 DC Specifications

Vdd = 3.3 V, Cs = 10 nF, load = 5 pF, 32 ms default sleep, Ta = recommended range, unless otherwise noted

Parameter	Description	Minimum	Typical	Maximum	Units	Notes
Vil	Low input logic level	–	–	0.2 × Vdd	V	
Vih	High input logic level	0.6 × Vdd	–	–	V	
Vol	Low output voltage	–	–	0.5	V	4 mA sink
Voh	High output voltage	Vdd – 0.7 V	–	–	V	1 mA source
Iil	Input leakage current	–	–	±1	µA	
Ar	Acquisition resolution	–	8	–	bits	

7.4 Current Consumption

Cs = 10nF, Cx = 5 pF, Rs = 10k

LP Mode	I _{dd} (μA) at V _{dd} =		
	5 V	3.3 V	1.8 V
0 (SLEEP)	2.48	1.8	1.1
1 (16 ms)	1745	1135	403
2 (32 ms)	1615	1065	373
4 (64 ms)	1545	1030	360
8 (128 ms)	1510	1010	351
16 (256 ms)	1500	1000	348
32 (512 ms)	1485	995	346
64 (1024 ms)	1475	992	345

7.5 Timing Specifications

Parameter	Description	Minimum	Typical	Maximum	Units	Notes
T _R	Response time	DI setting × 16 ms	–	LP mode + (DI setting × 16 ms)	ms	Under host control
F _{QT}	Sample frequency	162	180	198	kHz	Modulated spread-spectrum (chirp)
T _D	Power-up delay to operate/calibration time	–	<230	–	ms	Can be longer if burst is very long.
F _{I2C}	I ² C clock rate	–	–	100	kHz	–
F _m	Burst modulation,	–	±8	–	%	–
	Reset pulse width	5	–	–	μs	–
	Clock stretch	–	25	40	μs	–

7.6 Mechanical Dimensions

Note: The central pad on the underside of the QFN chip should be connected to ground. Do not run any tracks underneath the body of the chip, only ground.

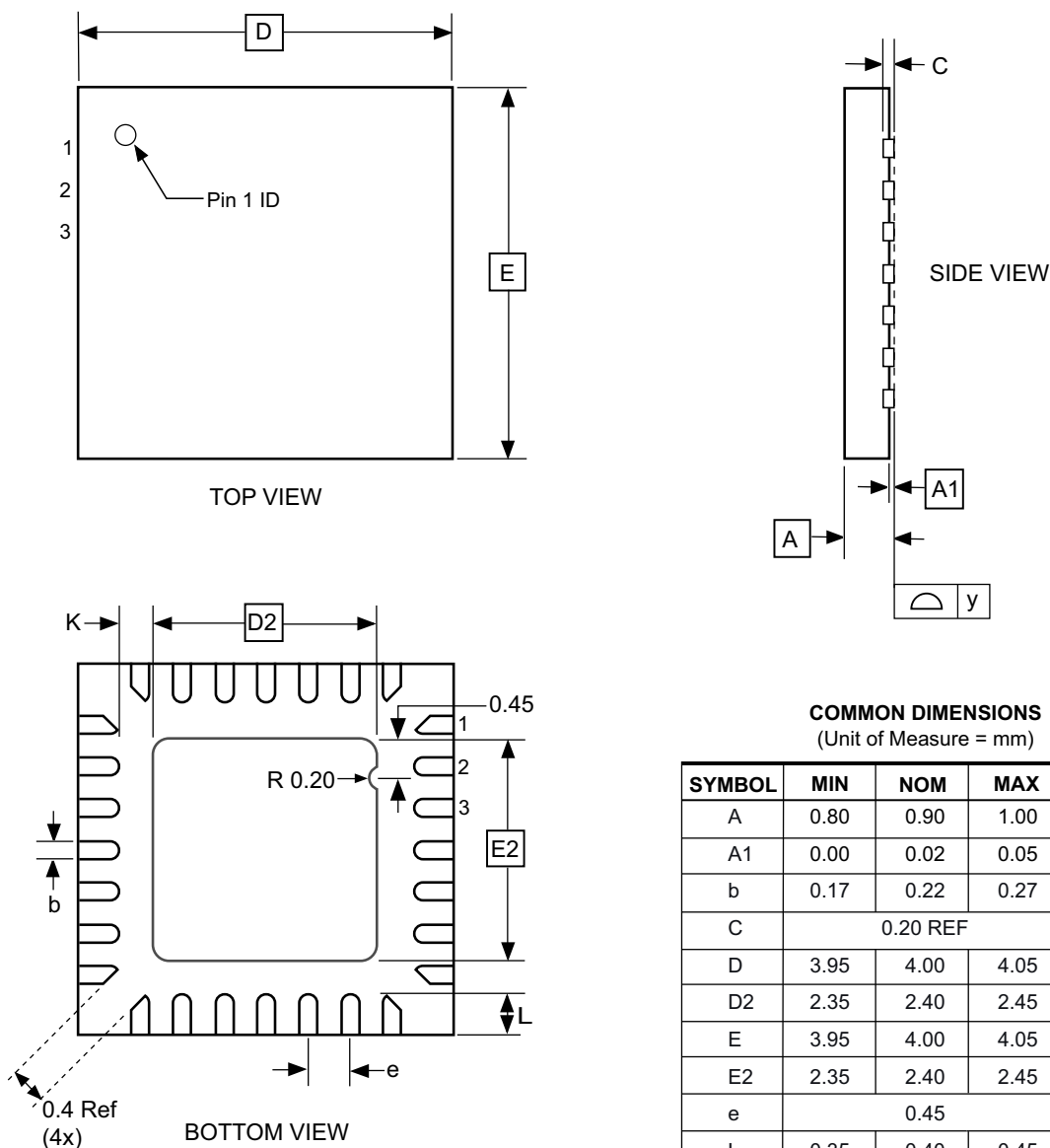

COMMON DIMENSIONS
(Unit of Measure = mm)

SYMBOL	MIN	NOM	MAX	NOTE
A	0.80	0.90	1.00	
A1	0.00	0.02	0.05	
b	0.17	0.22	0.27	
C	0.20 REF			
D	3.95	4.00	4.05	
D2	2.35	2.40	2.45	
E	3.95	4.00	4.05	
E2	2.35	2.40	2.45	
e	0.45			
L	0.35	0.40	0.45	
y	0.00	-	0.08	
K	0.20	-	-	

NOTES: The terminal #1 ID is a Laser-marked Feature.

1/10/13

Atmel

Package Drawing Contact:
packagedrawings@atmel.com

TITLE

28M1, 28-pad, 4 x 4 x 1.0 mm Body, Lead Pitch 0.45 mm,
2.4 x 2.4 mm Exposed Pad, Thermally Enhanced
Plastic Very Thin Quad Flat No Lead Package (VQFN)

GPC

ZBV

DRAWING NO.

28M1

REV.

C

7.7 Marking

There are two possible types of chip marking.

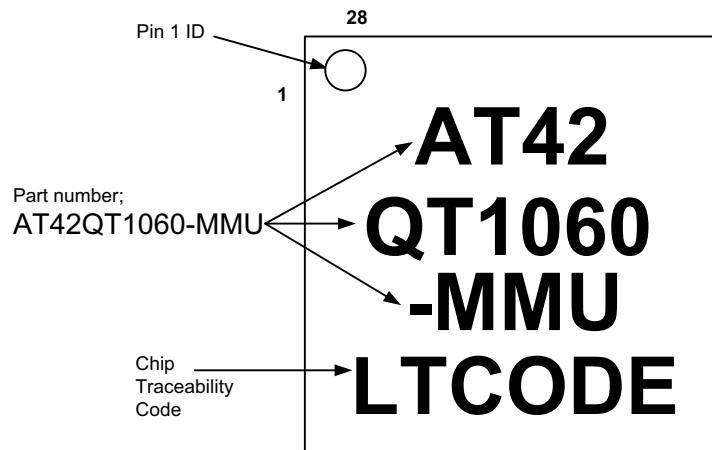
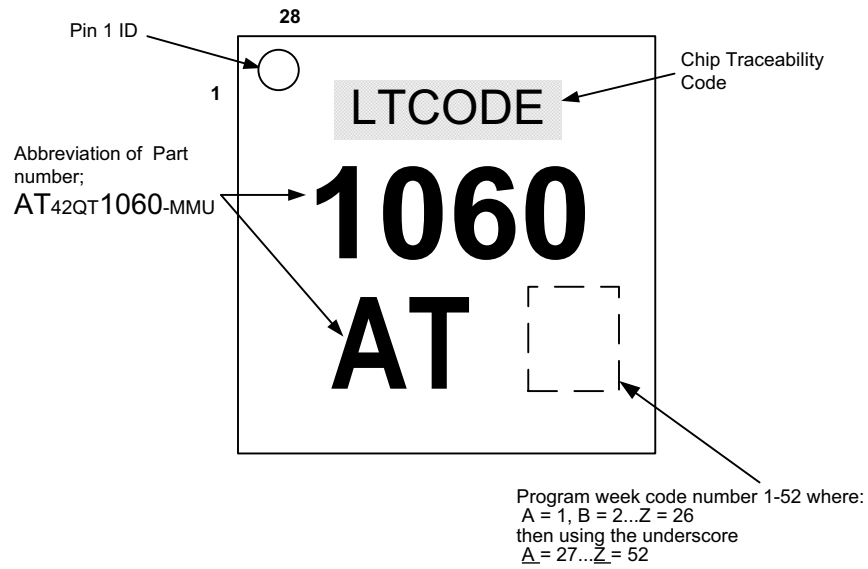

7.8 Part Number

Part Number	Description
AT42QT1060-MMU	28-pin 4 x 4 mm QFN RoHS compliant IC

The part number comprises:

AT = Atmel

42 = Touch Business Unit

QT = Charge-transfer technology

1060 = (1) Keys (06) number of channels (0) variant number

MMU = Package identifier

7.9 Moisture Sensitivity Level (MSL)

MSL Rating	Peak Body Temperature	Specifications
MSL1	260°C	IPC/JEDEC J-STD-020

Appendix A. I²C Basics

A.1 Interface Bus

The device communicates with the host over an I²C bus. The following sections give an overview of the bus; more detailed information is available from www.i2c-bus.org. Devices are connected to the I²C bus as shown in Figure A-1. Both bus lines are connected to Vdd via pull-up resistors. The bus drivers of all I²C devices must be open-drain type. This implements a wired AND function that allows any and all devices to drive the bus, one at a time. A low level on the bus is generated when a device outputs a zero.

Figure A-1. I²C Interface Bus

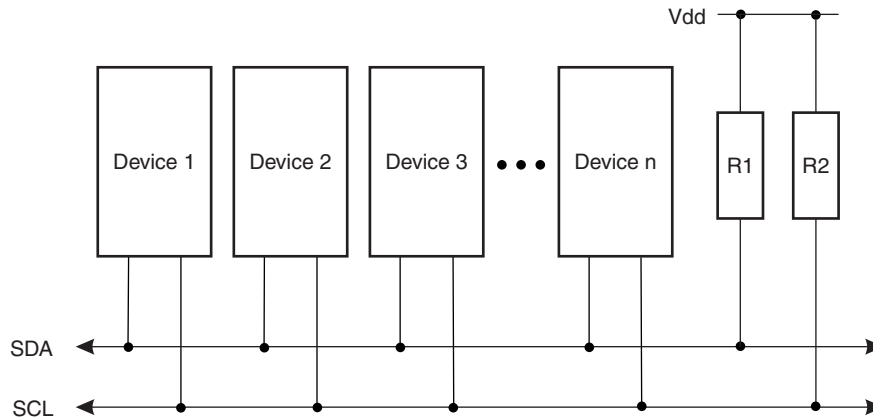

A.2 Transferring Data Bits

Each data bit transferred on the bus is accompanied by a pulse on the clock line. The level of the data line must be stable when the clock line is high; the only exception to this rule is for generating START and STOP conditions.

Figure A-2. Data Transfer

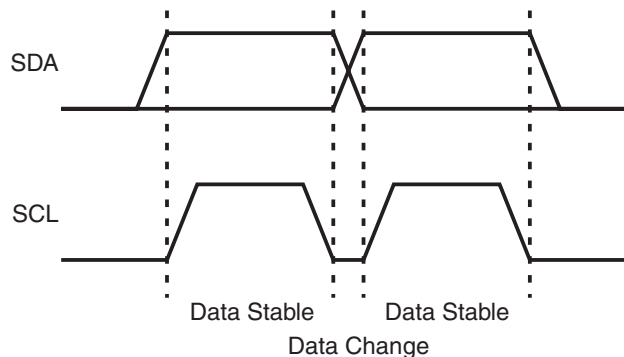

A.3 START and STOP Conditions

The host initiates and terminates a data transmission. The transmission is initiated when the host issues a START condition on the bus, and is terminated when the host issues a STOP condition. Between the START and STOP conditions, the bus is considered busy. As shown in Figure A-3, START and STOP conditions are signaled by changing the level of the SDA line when the SCL line is high.

Figure A-3. START and STOP Conditions

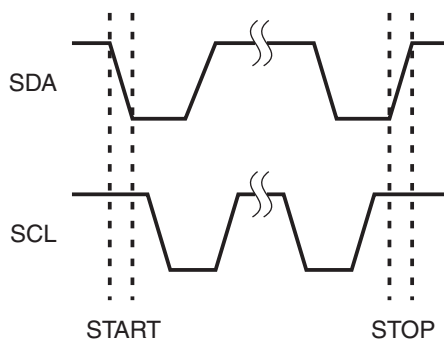

A.4 Address Byte Format

All address bytes are 9 bits long, consisting of 7 address bits, one READ/WRITE control bit and an acknowledge bit. If the READ/WRITE bit is set, a read operation is performed, otherwise a write operation is performed. When the device recognizes that it is being addressed, it will acknowledge by pulling SDA low in the ninth SCL (ACK) cycle. An address byte consisting of a slave address and a READ or a WRITE bit is called SLA+R or SLA+W, respectively.

The most significant bit of the address byte is transmitted first. The address sent by the host must be consistent with that selected with the option jumpers.

Figure A-4. Address Byte Format

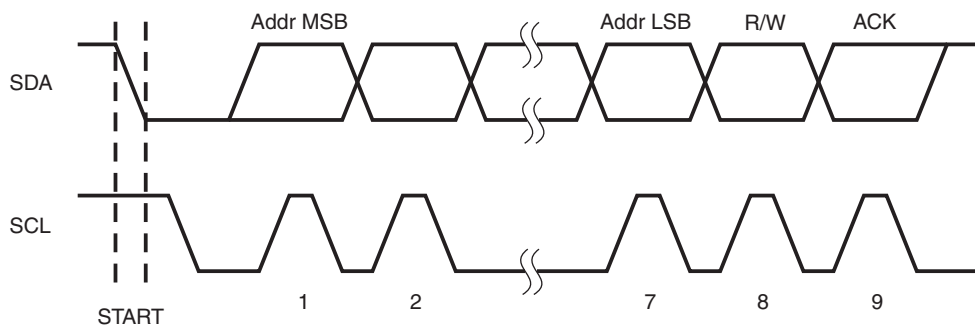

Revision History

Revision Number	History
Revision A – September 2008	<ul style="list-style-type: none">Initial Release for code revision 3.0
Revision B – October 2008	<ul style="list-style-type: none">Minor amendments to burst length limitations
Revision C – November 2008	<ul style="list-style-type: none">Minor amendments to improve clarity
Revision D – December 2008	<ul style="list-style-type: none">Chip ID updated
Revision E – February 2009	<ul style="list-style-type: none">Additional information on I²C interface added
Revision F – November 2012	<ul style="list-style-type: none">Updated PWM information and clock stretch timing added
Revision G – May 2013	<ul style="list-style-type: none">Applied new template
Revision H – April 2015	<ul style="list-style-type: none">Updated MSL value from 3 to 1



Atmel Corporation 1600 Technology Drive, San Jose, CA 95110 USA T: (+1)(408) 441.0311 F: (+1)(408) 436.4200 | www.atmel.com

© 2015 Atmel Corporation. / Rev.: Atmel-9505H-AT42_04/2015.

Atmel®, Atmel logo, Enabling Unlimited Possibilities® and combinations thereof, Adjacent Key Suppression®, AKS®, QTouch®, and others are registered trademarks or trademarks of Atmel Corporation or its subsidiaries. Other terms and product names may be trademarks of others.

DISCLAIMER: The information in this document is provided in connection with Atmel products. No license, express or implied, by estoppel or otherwise, to any intellectual property right is granted by this document or in connection with the sale of Atmel products. EXCEPT AS SET FORTH IN THE ATMEL TERMS AND CONDITIONS OF SALES LOCATED ON THE ATMEL WEBSITE, ATMEL ASSUMES NO LIABILITY WHATSOEVER AND DISCLAIMS ANY EXPRESS, IMPLIED OR STATUTORY WARRANTY RELATING TO ITS PRODUCTS INCLUDING, BUT NOT LIMITED TO, THE IMPLIED WARRANTY OF MERCHANTABILITY, FITNESS FOR A PARTICULAR PURPOSE, OR NON-INFRINGEMENT. IN NO EVENT SHALL ATMEL BE LIABLE FOR ANY DIRECT, INDIRECT, CONSEQUENTIAL, PUNITIVE, SPECIAL OR INCIDENTAL DAMAGES (INCLUDING, WITHOUT LIMITATION, DAMAGES FOR LOSS AND PROFITS, BUSINESS INTERRUPTION, OR LOSS OF INFORMATION) ARISING OUT OF THE USE OR INABILITY TO USE THIS DOCUMENT, EVEN IF ATMEL HAS BEEN ADVISED OF THE POSSIBILITY OF SUCH DAMAGES. Atmel makes no representations or warranties with respect to the accuracy or completeness of the contents of this document and reserves the right to make changes to specifications and products descriptions at any time without notice. Atmel does not make any commitment to update the information contained herein. Unless specifically provided otherwise, Atmel products are not suitable for, and shall not be used in, automotive applications. Atmel products are not intended, authorized, or warranted for use as components in applications intended to support or sustain life.

SAFETY-CRITICAL, MILITARY, AND AUTOMOTIVE APPLICATIONS DISCLAIMER: Atmel products are not designed for and will not be used in connection with any applications where the failure of such products would reasonably be expected to result in significant personal injury or death ("Safety-Critical Applications") without an Atmel officer's specific written consent. Safety-Critical Applications include, without limitation, life support devices and systems, equipment or systems for the operation of nuclear facilities and weapons systems. Atmel products are not designed nor intended for use in military or aerospace applications or environments unless specifically designated by Atmel as military-grade. Atmel products are not designed nor intended for use in automotive applications unless specifically designated by Atmel as automotive-grade.

AMEYA360

Components Supply Platform

Authorized Distribution Brand :



Website :

Welcome to visit www.ameya360.com

Contact Us :

➤ Address :

401 Building No.5, JiuGe Business Center, Lane 2301, Yishan Rd
Minhang District, Shanghai , China

➤ Sales :

Direct +86 (21) 6401-6692

Email amall@ameya360.com

QQ 800077892

Skype [ameyasales1](#) [ameyasales2](#)

➤ Customer Service :

Email service@ameya360.com

➤ Partnership :

Tel +86 (21) 64016692-8333

Email mkt@ameya360.com