

2A switch step down switching regulator

Features

- 2A internal switch
- Operating input voltage from 4.4V to 36V
- Output voltage adjustable from 1.235V to 35V
- Low dropout operation: 100% duty cycle
- 250kHz Internally fixed frequency
- Voltage feedforward
- Zero load current operation
- Internal current limiting
- Protection against feedback disconnection
- Thermal shutdown

Applications

- Consumer: STB, DVD, TV, VCR, car radio, LCD monitors
- Networking: XDSL, modems, DC-DC modules
- Computer: printers, audio/graphic cards, optical storage, hard disk drive
- Industrial: changers, car battery, DC-DC converters

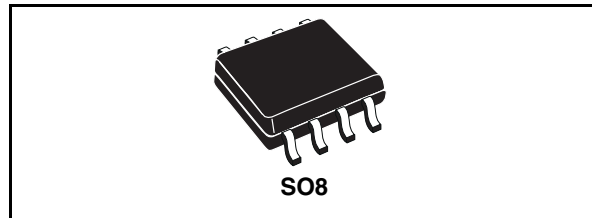

Description

The L5972D is a step down monolithic power switching regulator with a minimum switch current limit of 2A so it is able to deliver more than 1.5A DC current to the load depending on the application conditions.

The output voltage can be set from 1.235V to 35V.

The device uses an internal P-Channel D-MOS transistor (with a typical R_{dson} of 250m Ω) as switching element to minimize the size of the external components.

An internal oscillator fixes the switching frequency at 250kHz.

Having a minimum input voltage of 4.4V only, it is particularly suitable for 5V bus, available in all computer related applications.

Pulse by pulse current limit with the internal frequency modulation offers an effective constant current short circuit protection.

Figure 1. Test application circuit

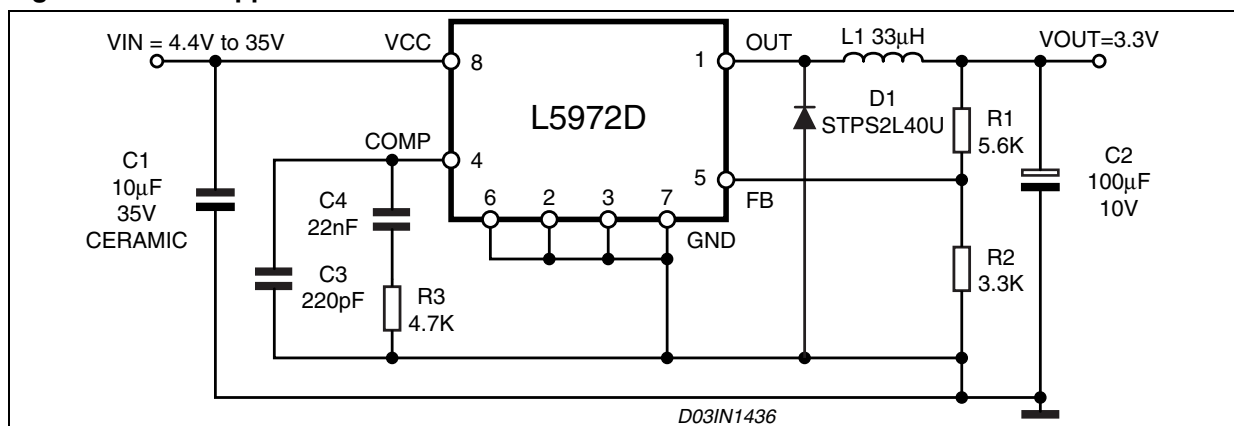

Contents

1	Pin settings	3
1.1	Pin connection	3
1.2	Pin description	3
2	Electrical data	4
2.1	Maximum ratings	4
2.2	Thermal data	4
3	Electrical characteristics	5
4	Typical characteristics	6
5	Application circuit	7
6	Application ideas	10
7	Package mechanical data	11
8	Order code	13
9	Revision history	14

1 Pin settings

1.1 Pin connection

Figure 2. Pin connection (top view)

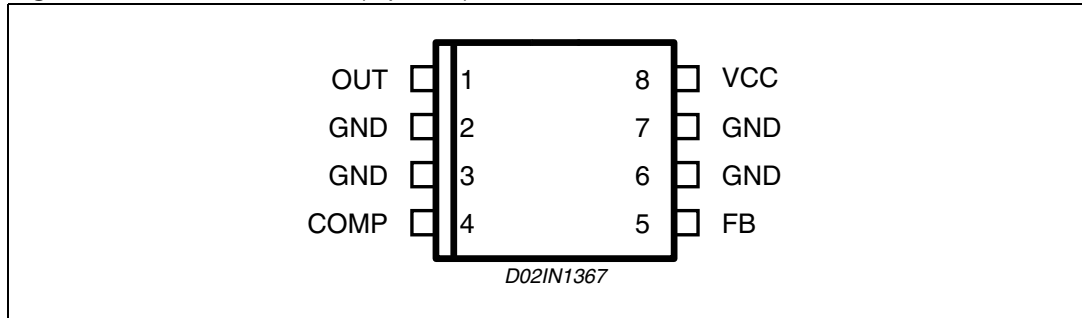

1.2 Pin description

Table 1. Pin description

N°	Pin	Description
1	OUT	Regulator output.
2,3,6,7	GND	Ground.
4	COMP	E/A output for frequency compensation.
5	FB	Feedback input. Connecting directly to this pin results in an output voltage of 1.23V. An external resistive divider is required for higher output voltages.
8	VCC	Unregulated DC input voltage.

2 Electrical data

2.1 Maximum ratings

Table 2. Absolute maximum ratings

Symbol	Parameter	Value	Unit
V_8	Input voltage	40	V
V_1	Out pin DC voltage	-1 to 40	V
	Out pin peak voltage at $\Delta t = 0.1\mu\text{s}$	-5 to 40	V
I_1	Maximum output current	int. limit.	
V_4, V_5	Analog pins	4	V
P_{tot}	Power dissipation at $T_A \leq 70^\circ\text{C}$	1.2	W
T_j	Operating junction temperature range	-40 to 150	$^\circ\text{C}$
T_{stg}	Storage temperature range	-55 to 150	$^\circ\text{C}$

2.2 Thermal data

Table 3. Thermal data

Symbol	Parameter	SO8	Unit
R_{thJA}	Maximum thermal resistance junction-ambient	65 ⁽¹⁾	$^\circ\text{C/W}$

1. Package mounted on board

3 Electrical characteristics

Table 4. Electrical characteristics ($T_J = 25^\circ\text{C}$, $V_{CC} = 12\text{V}$, unless otherwise specified)

Symbol	Parameter	Test condition		Min	Typ	Max	Unit
V_{CC}	Operating input voltage range	$V_o = 1.235\text{V}$; $I_o = 2\text{A}$	(1)	4.4		36	V
$R_{DS(on)}$	Mosfet on Resistance		(1)		0.250	0.5	Ω
I_l	Maximum limiting current	$V_{CC} = 4.4\text{V to } 36\text{V}$		2	2.5	3	A
f_s	Switching frequency		(1)	212	250	280	kHz
				225	250	275	kHz
	Duty cycle			0		100	%
Dynamic characteristics (see test circuit).							
V_5	Voltage feedback	$4.4\text{V} < V_{CC} < 36\text{V}$, $20\text{mA} < I_o < 2\text{A}$		1.220	1.235	1.25	V
			(1)	1.198	1.235	1.272	V
h	Efficiency	$V_o = 5\text{V}$, $V_{CC} = 12\text{V}$			90		%
DC characteristics							
I_{qop}	Total operating quiescent current		(1)		3	5	mA
I_q	Quiescent current	Duty cycle = 0; $V_{FB} = 1.5\text{V}$				2.5	mA
Error amplifier							
V_{OH}	High level output voltage	$V_{FB} = 1\text{V}$		3.5			V
V_{OL}	Low level output voltage	$V_{FB} = 1.5\text{V}$				0.4	V
$I_{o\ source}$	Source output current	$V_{COMP} = 1.9\text{V}$; $V_{FB} = 1\text{V}$		200	300		μA
$I_{o\ sink}$	Sink output current	$V_{COMP} = 1.9\text{V}$; $V_{FB} = 1.5\text{V}$		1	1.5		mA
I_b	Source bias current				2.5	4	μA
	DC open loop gain	$R_L = \infty$		50	65		dB
g_m	Transconductance	$I_{comp} = -0.1\text{mA to } 0.1\text{mA}$ $V_{COMP} = 1.9\text{V}$			2.3		mS

1. Specification Referred to T_J from -40 to 125°C . Specification over the -40 to $+125$ T_J Temperature range are assured by design, characterization and statistical correlation.

4 Typical characteristics

Figure 3. Output voltage vs. junction temperature

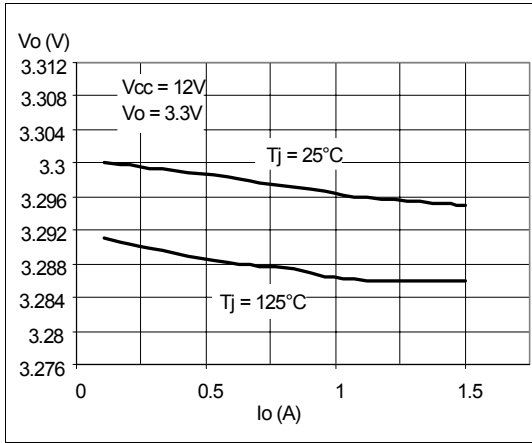

Figure 4. Quiescent current vs. junction temperature

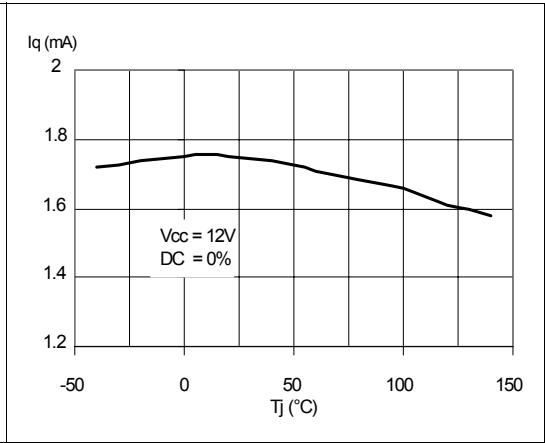

Figure 5. Line regulator

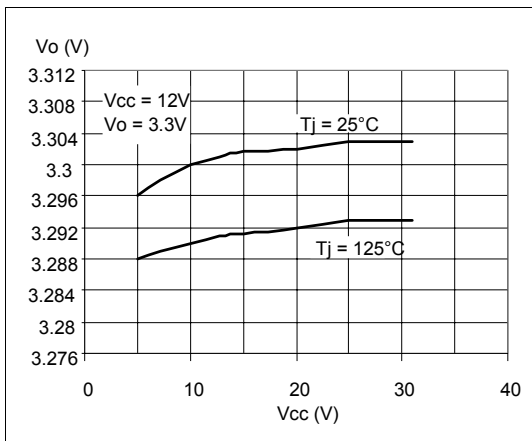

Figure 6. Shutdown current vs. junction temperature

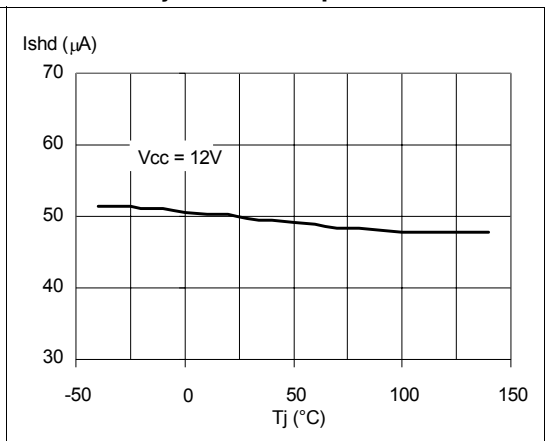

Figure 7. Output voltage vs. junction temperature

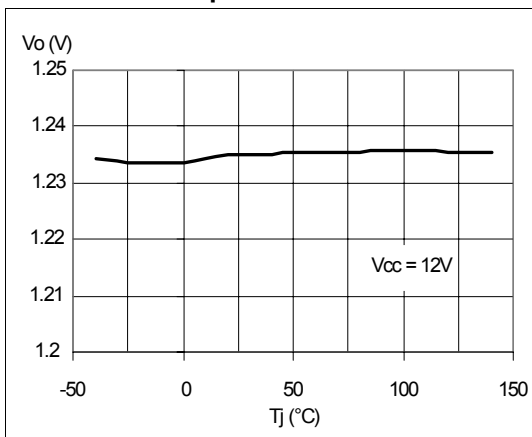
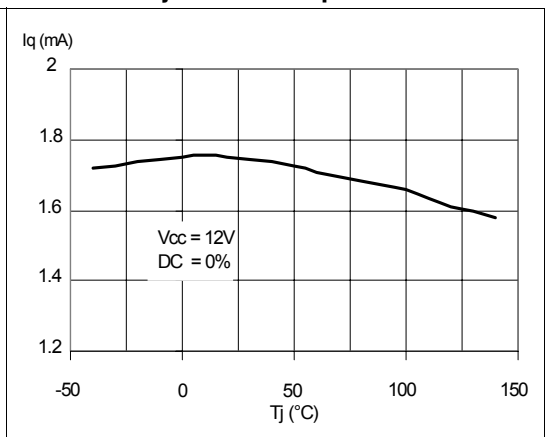

Figure 8. Switching frequency vs. junction temperature



5 Application circuit

In figure 8 is shown the demo board application circuit for the device in SMD version, where the input supply voltage, V_{CC} , can range from 4.4V to 25V due to the rated voltage of the input capacitor and the output voltage is adjustable from 1.235V to V_{CC} .

Figure 9. Demo board application circuit

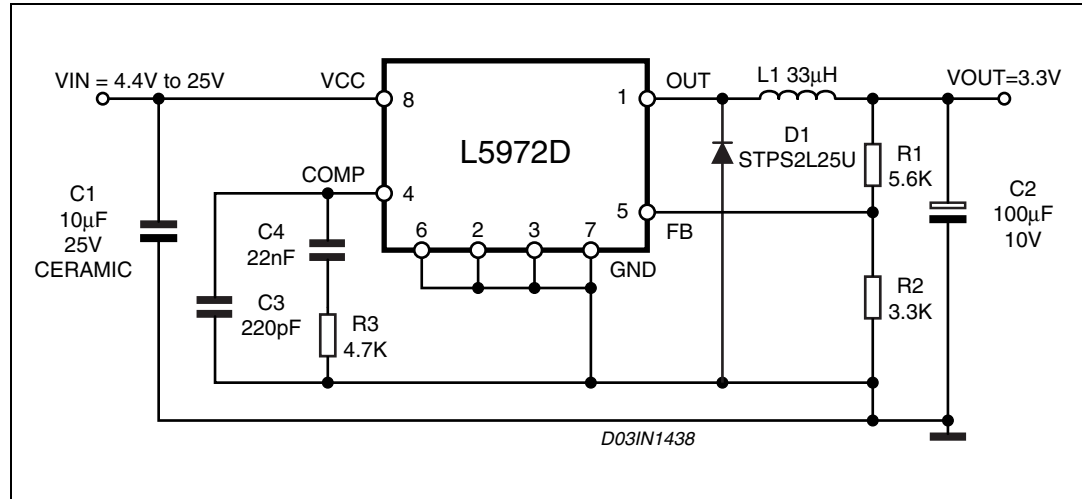

Table 5. Component list

Reference	Part number	Description	Manufacturer
C1	GRM32DR61E106KA12L	10µF, 25V	MURATA
C2	POSCAP 10TPB100M	100µF, 10V	Sanyo
C3	C1206C221J5GAC	220pF, 5%, 50V	KEMET
C4	C1206C223K5RAC	22nF, 10%, 50V	KEMET
R1		5.6K, 1%, 0.1W 0603	Neohm
R2		3.3K, 1%, 0.1W 0603	Neohm
R3		4.7K, 1%, 0.1W 0603	Neohm
D1	STPS2L25U	2A, 25V	ST
L1	DO3316P-333	33µH, 2.1A	COILCRAFT

Figure 10. PCB layout (component side)

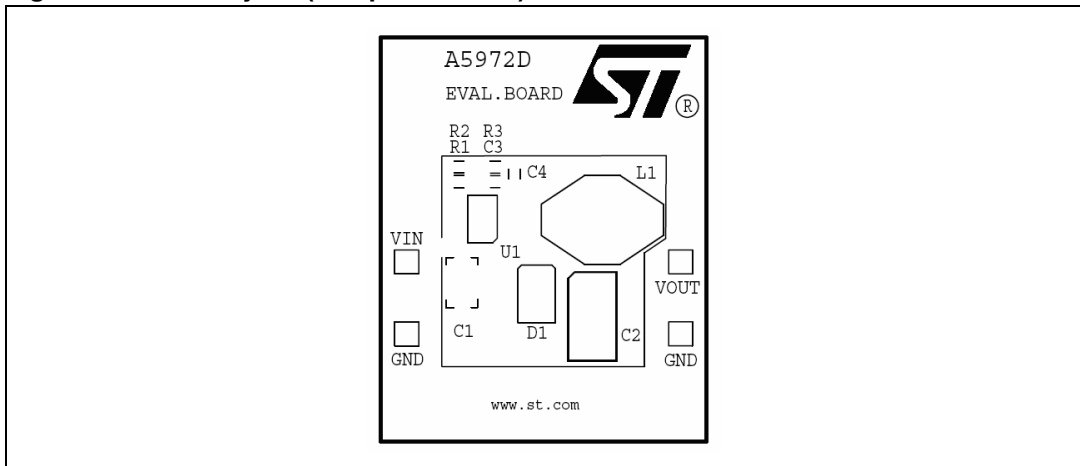

Figure 11. PCB layout (bottom side)

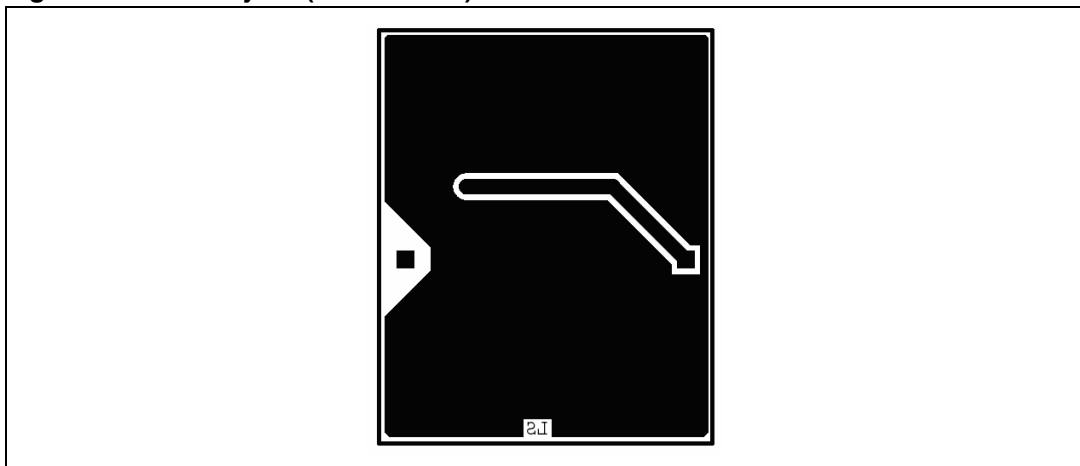
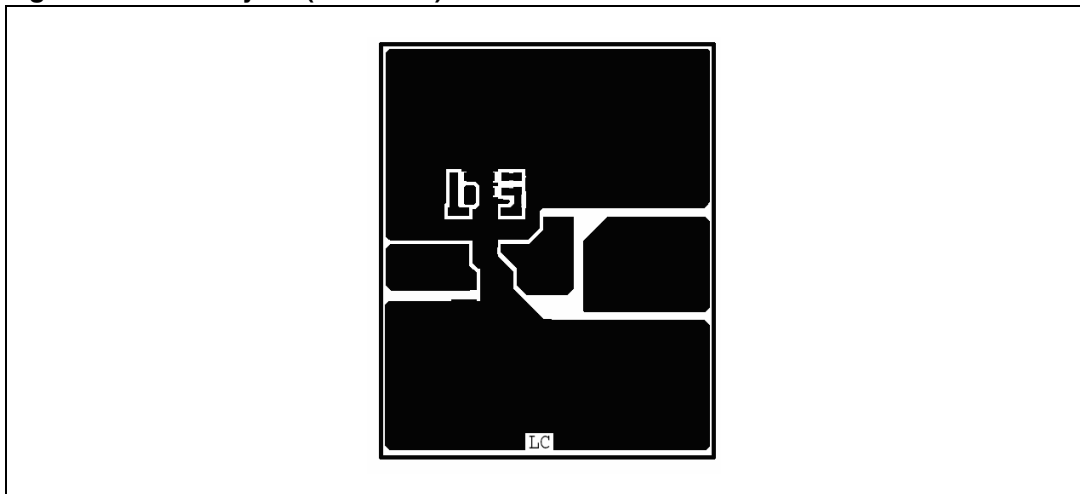

Figure 12. PCB layout (front side)



Sideways two graphs show the T_J versus output current in different conditions of the input and output voltage.

Figure 13. Junction temperature vs output current

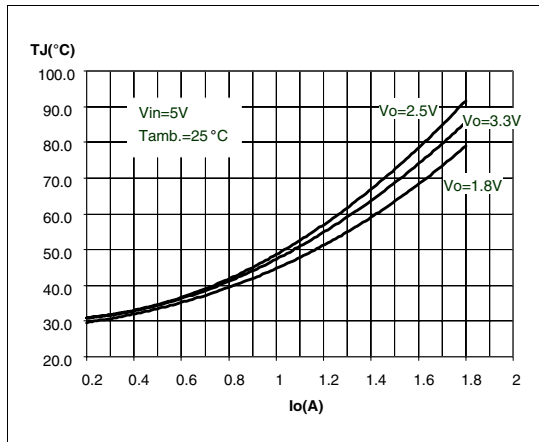

Figure 14. Efficiency vs output current

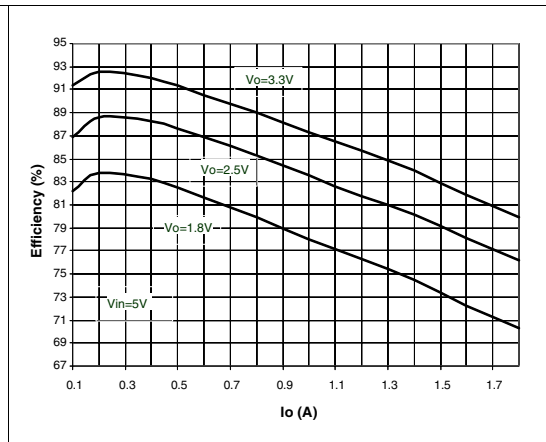

Figure 15. Junction temperature vs output current

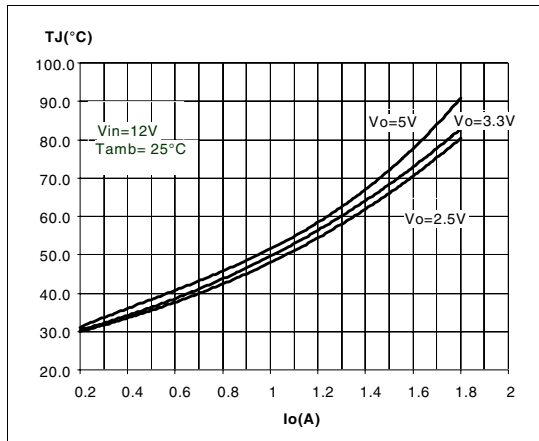
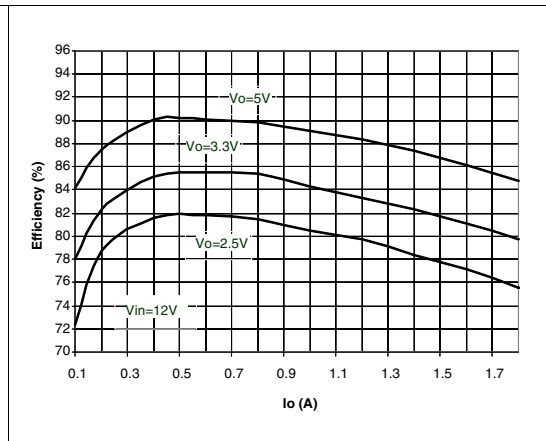

Figure 16. Efficiency vs output current



6 Application ideas

Figure 17. Positive buck-boost regulator

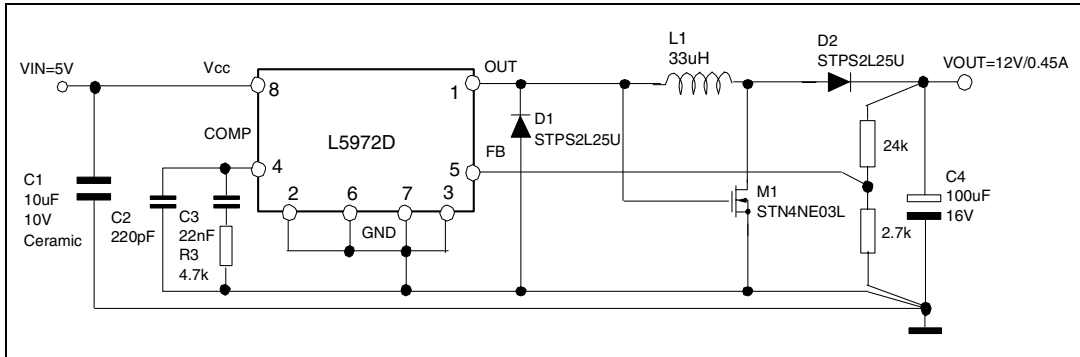

Figure 18. Buck-boost regulator

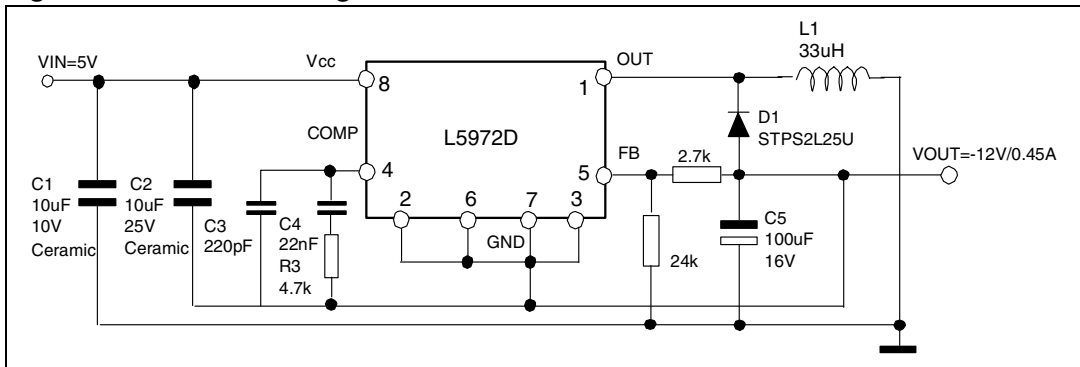
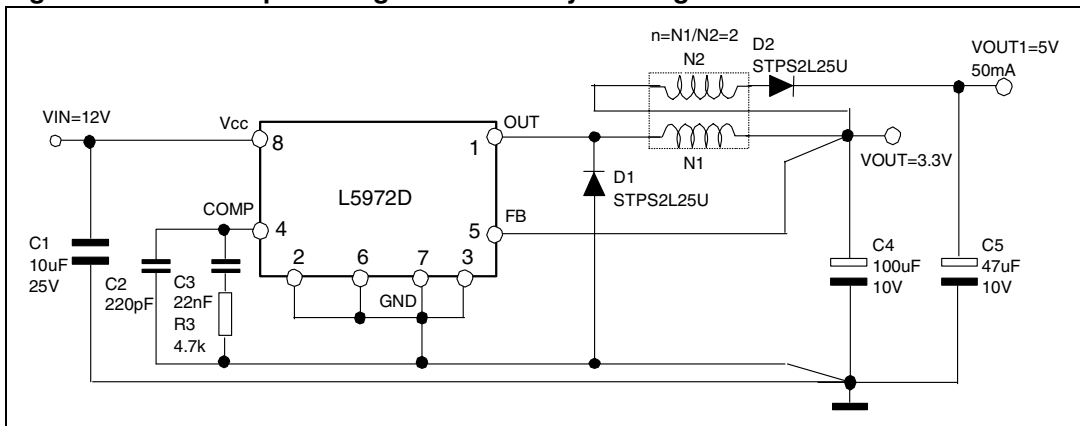

Figure 19. Dual output voltage with auxiliary winding



7 Package mechanical data

In order to meet environmental requirements, ST offers these devices in ECOPACK® packages. These packages have a Lead-free second level interconnect . The category of second level interconnect is marked on the package and on the inner box label, in compliance with JEDEC Standard JESD97. The maximum ratings related to soldering conditions are also marked on the inner box label. ECOPACK is an ST trademark. ECOPACK specifications are available at: www.st.com

Table 6. SO-8 Mechanical data

Dim.	mm.			inch		
	Min	Typ	Max	Min	Typ	Max
A	1.35		1.75	0.053		0.069
A1	0.10		0.25	0.004		0.010
A2	1.10		1.65	0.043		0.065
B	0.33		0.51	0.013		0.020
C	0.19		0.25	0.007		0.010
D ⁽¹⁾	4.80		5.00	0.189		0.197
E	3.80		4.00	0.15		0.157
e		1.27			0.050	
H	5.80		6.20	0.228		0.244
h	0.25		0.50	0.010		0.020
L	0.40		1.27	0.016		0.050
k	0° (min.), 8° (max.)					
ddd			0.10			0.004

1. Dimensions D does not include mold flash, protrusions or gate burrs. Mold flash, protrusions or gate burrs shall not exceed 0.15mm (.006inch) in total (both side).

Figure 20. Package dimensions

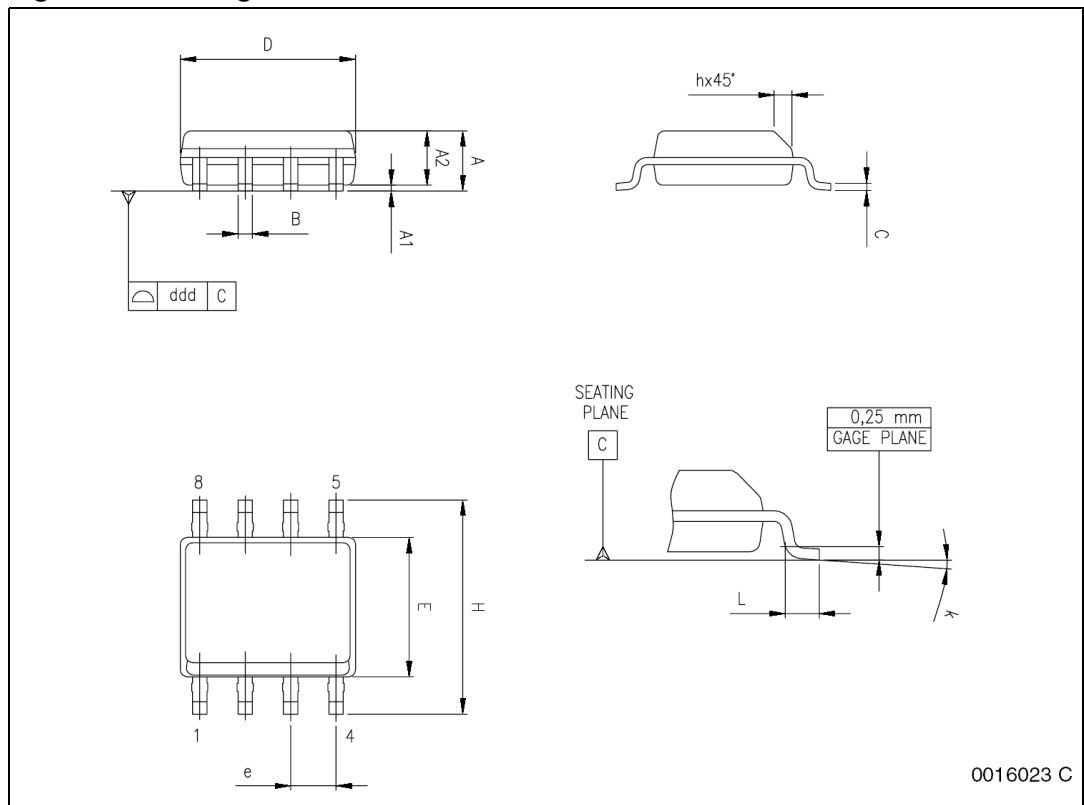

8 Order codes

Table 7. Order codes

Part number	Package	Packaging
L5972D	SO8	Tube
L5972D013TR	SO8	Tape and reel

9 Revision history

Table 8. Revision history

Date	Revision	Changes
02-Feb-2007	8	Updated Table 5 on page 7
10-Apr-2007	9	Mechanical data typo
16-Oct-2007	10	Updated Section 5: Application circuit on page 7

Please Read Carefully:

Information in this document is provided solely in connection with ST products. STMicroelectronics NV and its subsidiaries ("ST") reserve the right to make changes, corrections, modifications or improvements, to this document, and the products and services described herein at any time, without notice.

All ST products are sold pursuant to ST's terms and conditions of sale.

Purchasers are solely responsible for the choice, selection and use of the ST products and services described herein, and ST assumes no liability whatsoever relating to the choice, selection or use of the ST products and services described herein.

No license, express or implied, by estoppel or otherwise, to any intellectual property rights is granted under this document. If any part of this document refers to any third party products or services it shall not be deemed a license grant by ST for the use of such third party products or services, or any intellectual property contained therein or considered as a warranty covering the use in any manner whatsoever of such third party products or services or any intellectual property contained therein.

UNLESS OTHERWISE SET FORTH IN ST'S TERMS AND CONDITIONS OF SALE ST DISCLAIMS ANY EXPRESS OR IMPLIED WARRANTY WITH RESPECT TO THE USE AND/OR SALE OF ST PRODUCTS INCLUDING WITHOUT LIMITATION IMPLIED WARRANTIES OF MERCHANTABILITY, FITNESS FOR A PARTICULAR PURPOSE (AND THEIR EQUIVALENTS UNDER THE LAWS OF ANY JURISDICTION), OR INFRINGEMENT OF ANY PATENT, COPYRIGHT OR OTHER INTELLECTUAL PROPERTY RIGHT.

UNLESS EXPRESSLY APPROVED IN WRITING BY AN AUTHORIZED ST REPRESENTATIVE, ST PRODUCTS ARE NOT RECOMMENDED, AUTHORIZED OR WARRANTED FOR USE IN MILITARY, AIR CRAFT, SPACE, LIFE SAVING, OR LIFE SUSTAINING APPLICATIONS, NOR IN PRODUCTS OR SYSTEMS WHERE FAILURE OR MALFUNCTION MAY RESULT IN PERSONAL INJURY, DEATH, OR SEVERE PROPERTY OR ENVIRONMENTAL DAMAGE. ST PRODUCTS WHICH ARE NOT SPECIFIED AS "AUTOMOTIVE GRADE" MAY ONLY BE USED IN AUTOMOTIVE APPLICATIONS AT USER'S OWN RISK.

Resale of ST products with provisions different from the statements and/or technical features set forth in this document shall immediately void any warranty granted by ST for the ST product or service described herein and shall not create or extend in any manner whatsoever, any liability of ST.

ST and the ST logo are trademarks or registered trademarks of ST in various countries.

Information in this document supersedes and replaces all information previously supplied.

The ST logo is a registered trademark of STMicroelectronics. All other names are the property of their respective owners.

© 2007 STMicroelectronics - All rights reserved

STMicroelectronics group of companies

Australia - Belgium - Brazil - Canada - China - Czech Republic - Finland - France - Germany - Hong Kong - India - Israel - Italy - Japan - Malaysia - Malta - Morocco - Singapore - Spain - Sweden - Switzerland - United Kingdom - United States of America

www.st.com



AMEYA360

Components Supply Platform

Authorized Distribution Brand :



Website :

Welcome to visit www.ameya360.com

Contact Us :

➤ Address :

401 Building No.5, JiuGe Business Center, Lane 2301, Yishan Rd
Minhang District, Shanghai , China

➤ Sales :

Direct +86 (21) 6401-6692

Email amall@ameya360.com

QQ 800077892

Skype [ameyasales1](#) [ameyasales2](#)

➤ Customer Service :

Email service@ameya360.com

➤ Partnership :

Tel +86 (21) 64016692-8333

Email mkt@ameya360.com