

ULTRA-SMALL, LOW-INPUT VOLTAGE, LOW R_{ON} LOAD SWITCH

Check for Samples: [TPS22908](#)

FEATURES

- **Low Input Voltage: 1.0 V to 3.6 V**
- **Ultra-Low ON-State Resistance (R_{ON})**
- **Typical R_{ON} values**
 - $R_{ON} = 28\text{ m}\Omega$ at $V_{IN} = 3.6\text{ V}$
 - $R_{ON} = 33\text{ m}\Omega$ at $V_{IN} = 2.5\text{ V}$
 - $R_{ON} = 42\text{ m}\Omega$ at $V_{IN} = 1.8\text{ V}$
 - $R_{ON} = 70\text{ m}\Omega$ at $V_{IN} = 1.2\text{ V}$
- **1-A Maximum Continuous Switch Current**
- **Maximum Quiescent Current = 1 μA**
- **Maximum Shutdown Current = 1 μA**
- **Low Control Input Thresholds Enable Use of Low-Voltage Logic**
- **Controlled Slew Rate to Avoid Inrush Currents**
- **Ultra-Small Four Terminal Wafer-Chip-Scale Package (WCSP)**
 - **Nominal Dimensions - See Addendum for Details**
 - **0.9 mm \times 0.9 mm**
 - **0.5-mm Pitch, 0.6-mm Height**
- **Quick Output Discharge (QOD)**

APPLICATIONS

- **Battery Powered Equipment**
- **Portable Industrial Equipment**
- **Portable Medical Equipment**
- **Portable Media Players**
- **Point of Sale Terminal**
- **GPS Devices**
- **Digital Cameras**
- **Portable Instrumentation**
- **Smartphones / Tablets**

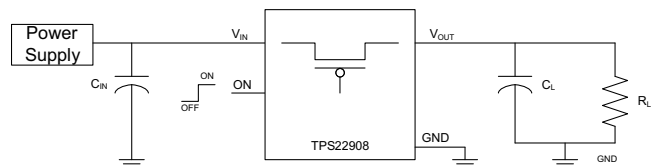
Figure 1. Typical Application

DESCRIPTION

The TPS22908 is an ultra small, low R_{ON} load switch with controlled turn-on. The device contains a P-channel MOSFET that operates over an input voltage range of 1.0 V to 3.6 V. The switch is controlled by an on/off input (ON), which is capable of interfacing directly with low-voltage control signals.

The TPS22908 is available in a space-saving 4-terminal WCSP with 0.5-mm pitch (YZT). The device is characterized for operation over the free-air temperature range of -40°C to 85°C .

ORDERING INFORMATION

For package and ordering information, see the Package Option Addendum at the end of this document.

FEATURE LIST

DEVICE	R_{ON} (typical) $V_{IN} = 3.6\text{ V}$	RISE TIME (typical) $V_{IN} = 3.6\text{ V}$	QUICK OUTPUT DISCHARGE ⁽¹⁾	MAXIMUM CURRENT	ENABLE
TPS22908	28 m Ω	105 μs	Yes	1 A	Active high

(1) This feature discharges the output of the switch to ground through an 80- Ω resistor, preventing the output from floating.



Please be aware that an important notice concerning availability, standard warranty, and use in critical applications of Texas Instruments semiconductor products and disclaimers thereto appears at the end of this data sheet.

TPS22908

SLVSB17B – JULY 2012 – REVISED MAY 2013

www.ti.com



This integrated circuit can be damaged by ESD. Texas Instruments recommends that all integrated circuits be handled with appropriate precautions. Failure to observe proper handling and installation procedures can cause damage.

ESD damage can range from subtle performance degradation to complete device failure. Precision integrated circuits may be more susceptible to damage because very small parametric changes could cause the device not to meet its published specifications.

ABSOLUTE MAXIMUM RATINGS

Over operating free-air temperature range (unless otherwise noted)⁽¹⁾

		VALUE	UNIT ⁽²⁾	
V _{IN}	Supply voltage range	-0.3 to 4	V	
V _{OUT}	Output voltage range	-0.3 to (V _{IN} + 0.3)	V	
V _{ON}	Input voltage range	-0.3 to 4	V	
I _{MAX}	Maximum Continuous Switch Current for V _{IN} >= 1.2V	1	A	
	Maximum Continuous Switch Current at V _{IN} = 1.0V	0.6		
T _A	Operating free-air temperature range ⁽³⁾	-40 to 85	°C	
T _J	Maximum junction temperature	125	°C	
T _{STG}	Storage temperature range	-65 to 150	°C	
T _{LEAD}	Maximum lead temperature (10-s soldering time)	300	°C	
ESD	Electrostatic discharge protection	Human-Body Model (HBM)	2000	V
		Charged-Device Model (CDM)	1000	

- (1) Stresses beyond those listed under absolute maximum ratings may cause permanent damage to the device. These are stress ratings only, and functional operation of the device at these or any other conditions beyond those indicated under recommended operating conditions is not implied. Exposure to absolute-maximum-rated conditions for extended periods may affect device reliability.
- (2) All voltage values are with respect to network ground terminal.
- (3) In applications where high power dissipation and/or poor package thermal resistance is present, the maximum ambient temperature may have to be derated. Maximum ambient temperature [T_{A(max)}] is dependent on the maximum operating junction temperature [T_{J(max)}], the maximum power dissipation of the device in the application [P_{D(max)}], and the junction-to-ambient thermal resistance of the part/package in the application (θ_{JA}), as given by the following equation: T_{A(max)} = T_{J(max)} - (θ_{JA} × P_{D(max)})

THERMAL INFORMATION

THERMAL METRIC ⁽¹⁾⁽²⁾		TPS22908	UNITS
		YZT (4 PINS)	
θ _{JA}	Junction-to-ambient thermal resistance	188	°C/W
θ _{JC(top)}	Junction-to-case(top) thermal resistance	2	
θ _{JB}	Junction-to-board thermal resistance	33	
Ψ _{JT}	Junction-to-top characterization parameter	9.1	
Ψ _{JB}	Junction-to-board characterization parameter	33	
θ _{JC(bottom)}	Junction-to-case(bottom) thermal resistance	N/A	

- (1) For more information about traditional and new thermal metrics, see the IC Package Thermal Metrics application report, [SPRA953](#)
- (2) For thermal estimates of this device based on PCB copper area, see the TI PCB Thermal Calculator.

RECOMMENDED OPERATING CONDITIONS

		MIN	MAX	UNIT
V _{IN}	Input voltage range	1.0	3.6	V
V _{ON}	ON voltage range	0	3.6	V
V _{OUT}	Output voltage range	0	V _{IN}	V
V _{IH}	High-level input voltage, ON	0.85	3.6	V
V _{IL}	Low-level input voltage, ON	0	0.4	V
C _{IN}	Input capacitor	1 ⁽¹⁾		μF

- (1) Refer to application section.

ELECTRICAL CHARACTERISTICS

Unless otherwise noted the specification applies over the operating ambient temp $-40^{\circ}\text{C} \leq T_A \leq 85^{\circ}\text{C}$. Typical values are for $V_{IN} = 3.6\text{ V}$, and $T_A = 25^{\circ}\text{C}$ unless otherwise noted.

PARAMETER		TEST CONDITIONS	T_A	MIN	TYP	MAX	UNIT			
POWER SUPPLIES AND CURRENTS										
I_{IN}	Quiescent current	$I_{OUT} = 0\text{ mA}$, $V_{IN} = V_{ON}$	Full		0.19	1	μA			
$I_{IN(OFF)}$	OFF-state supply current	$V_{ON} = 0\text{ V}$, $V_{OUT} = \text{Open}$	Full		0.12	1	μA			
$I_{IN(LEAK)}$	OFF-state supply current	$V_{ON} = 0\text{ V}$, $V_{OUT} = 0\text{ V}$	Full		0.12	1	μA			
I_{ON}	ON pin input leakage current	$V_{ON} = 1.1\text{ V to }3.6\text{ V}$	Full		0.01	0.1	μA			
RESISTANCE AND SWITCH CHARACTERISTICS										
R_{ON}	ON-state resistance	$I_{OUT} = -200\text{ mA}$	$V_{IN} = 3.6\text{ V}$	25°C	28.2	32.1	m Ω			
				Full		34.9				
			$V_{IN} = 2.5\text{ V}$	25°C	33.1	37.5	m Ω			
				Full		40.6				
			$V_{IN} = 1.8\text{ V}$	25°C	41.5	50.3	m Ω			
				Full		54.0				
			$V_{IN} = 1.2\text{ V}$	25°C	69.7	87.3	m Ω			
				Full		91.2				
			$V_{IN} = 1.0\text{ V}$	25°C	112	155	m Ω			
				Full		156				
			R_{PD}	Output pulldown resistance	$V_{IN} = 3.3\text{ V}$, $V_{ON} = 0\text{ V}$, $I_{OUT} = 30\text{ mA}$	25°C		80	100	Ω

SWITCHING CHARACTERISTIC MEASUREMENT INFORMATION

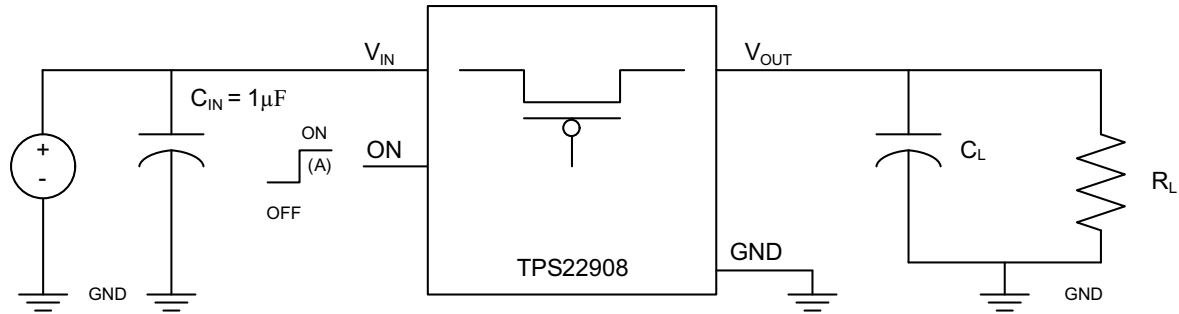

TEST CIRCUIT

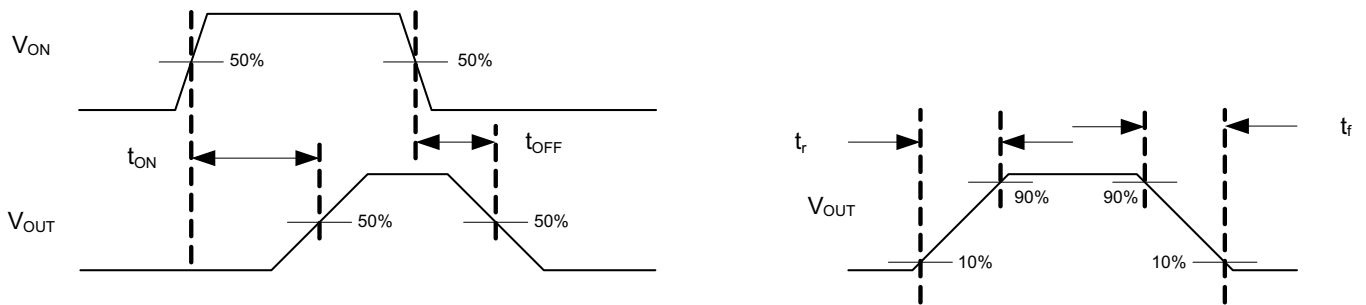

t_{ON}/t_{OFF} WAVEFORMS

A. Rise and fall times of the control signal is 100 ns.

Figure 2. Test Circuit and t_{ON}/t_{OFF} Waveforms

SWITCHING CHARACTERISTICS

PARAMETER	TEST CONDITION	TPS22908			UNIT
		MIN	TYP	MAX	
V_{IN} = 3.6 V, T_A = 25°C (unless otherwise noted)					
t _{ON} Turn-ON time	R _L = 10 Ω, C _L = 0.1 µF		110		µs
t _{OFF} Turn-OFF time	R _L = 10 Ω, C _L = 0.1 µF		5		
t _R V _{OUT} Rise time	R _L = 10 Ω, C _L = 0.1 µF		105		
t _F V _{OUT} Fall time	R _L = 10 Ω, C _L = 0.1 µF		2		
V_{IN} = 1.0 V, T_A = 25°C (unless otherwise noted)					
t _{ON} Turn-ON time	R _L = 10 Ω, C _L = 0.1 µF		493		µs
t _{OFF} Turn-OFF time	R _L = 10 Ω, C _L = 0.1 µF		7		
t _R V _{OUT} Rise time	R _L = 10 Ω, C _L = 0.1 µF		442		
t _F V _{OUT} Fall time	R _L = 10 Ω, C _L = 0.1 µF		2		

FUNCTIONAL BLOCK DIAGRAM and PIN DESCRIPTIONS

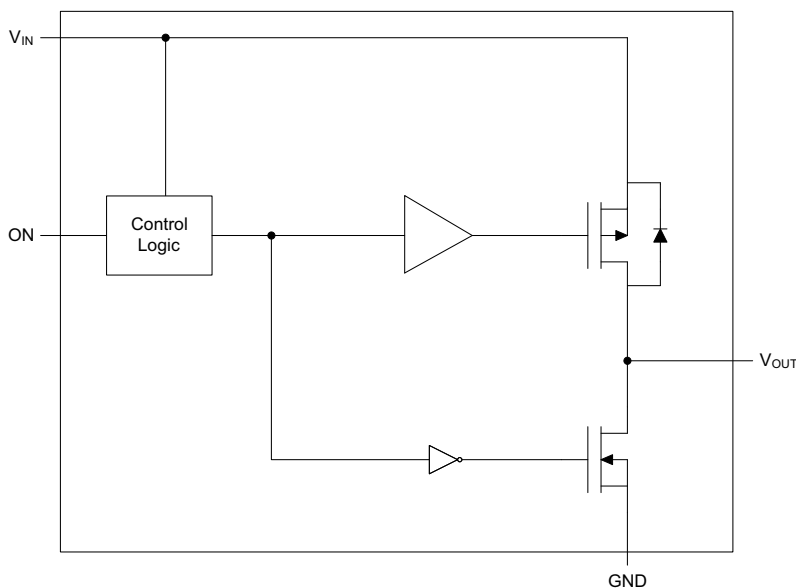

Figure 3. Functional Block Diagram

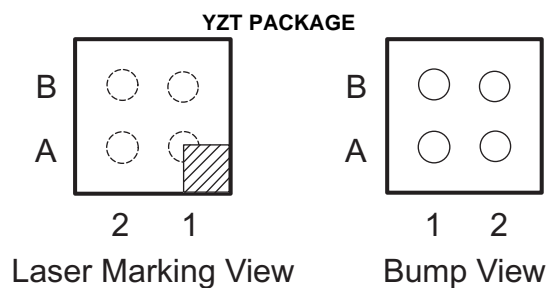

Table 1. FUNCTIONAL TABLE

ON	V _{IN} to V _{OUT}	V _{OUT} to GND
L	Off	On
H	On	Off

PIN DESCRIPTIONS

TPS22908 YZT	PIN NAME	DESCRIPTION
B2	ON	Switch control input, active high. Do not leave floating.
B1	GND	Ground
A2	V _{IN}	Switch input, bypass capacitor recommended for minimizing V _{IN} dip. See Application Information.
A1	V _{OUT}	Switch output

TYPICAL DC CHARACTERISTICS

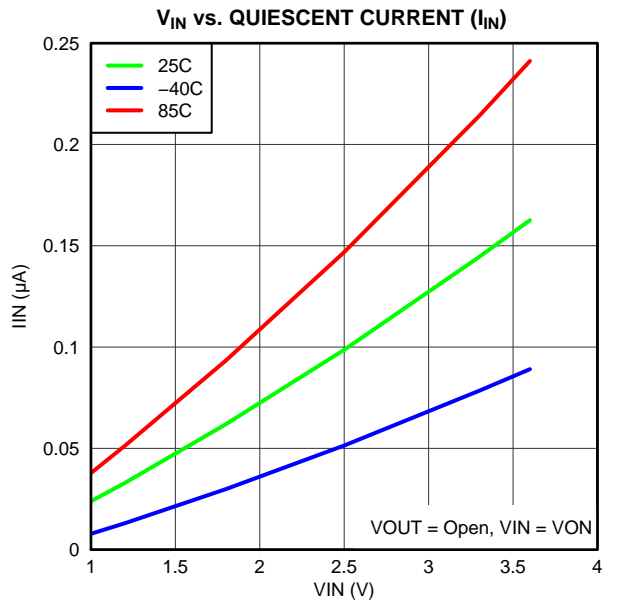

Figure 4.

G003

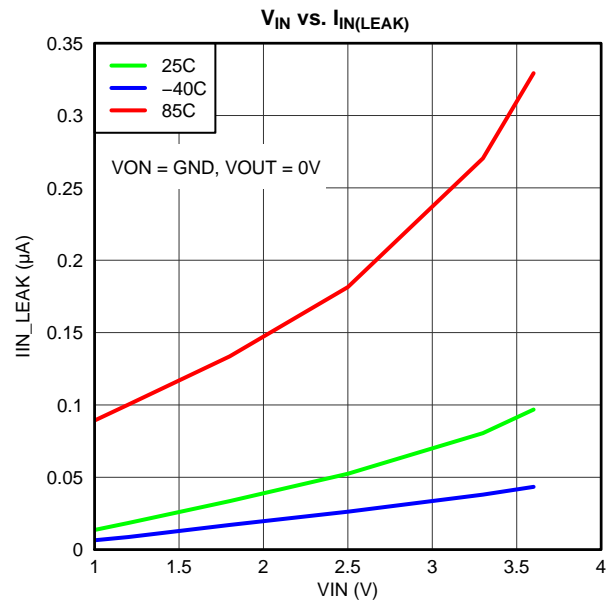

Figure 5.

G004

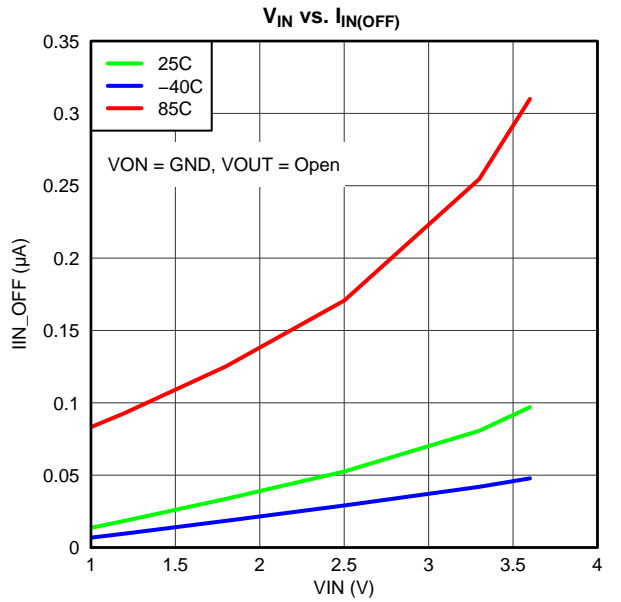

Figure 6.

G005

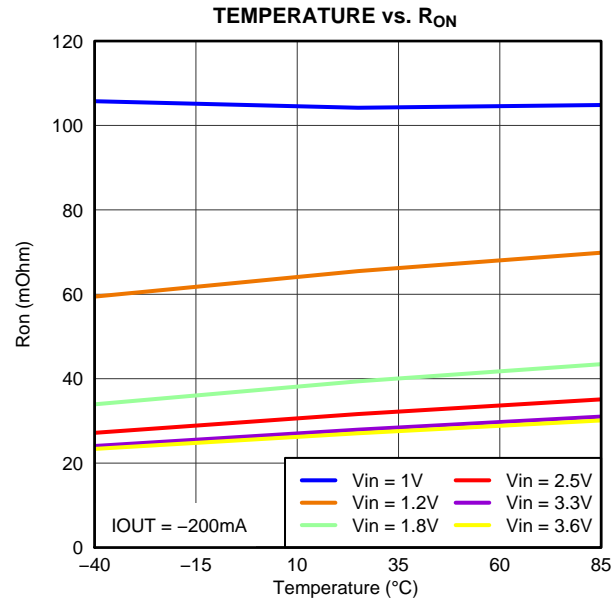

Figure 7.

G002

TYPICAL DC CHARACTERISTICS (continued)

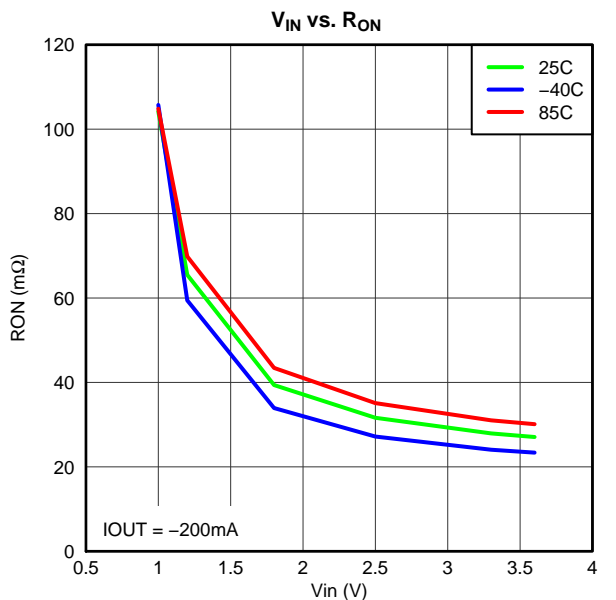

Figure 8.

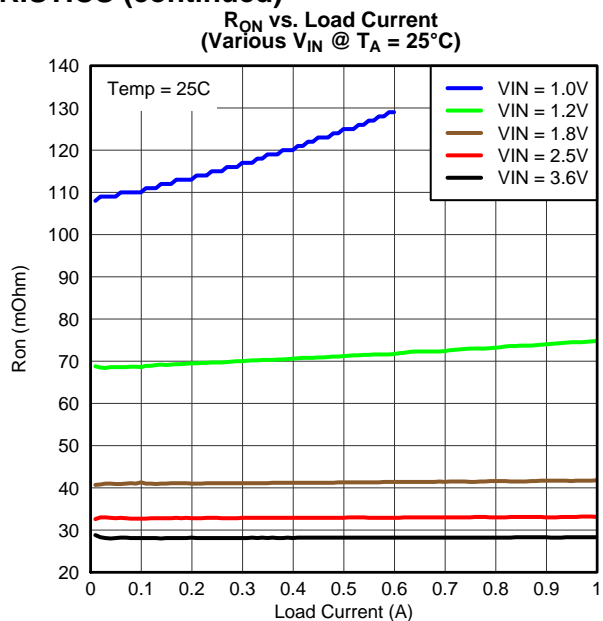

Figure 9.

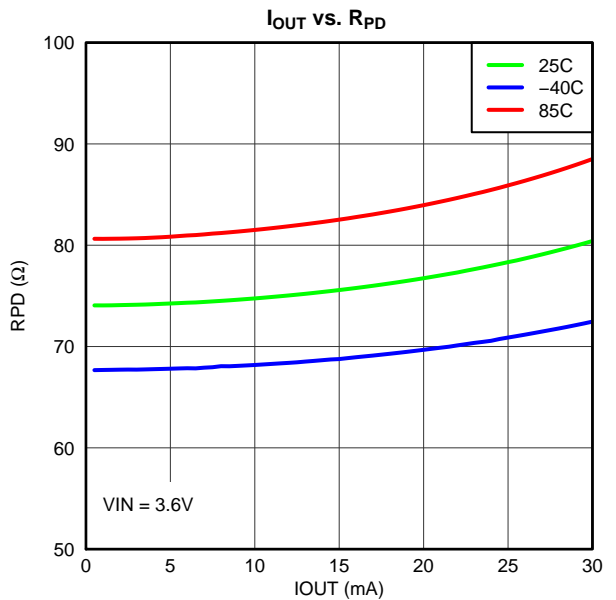

Figure 10.

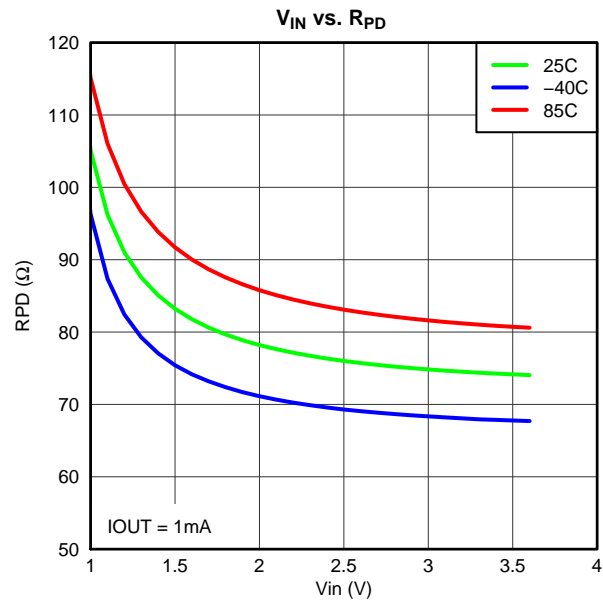

Figure 11.

TYPICAL DC CHARACTERISTICS (continued)

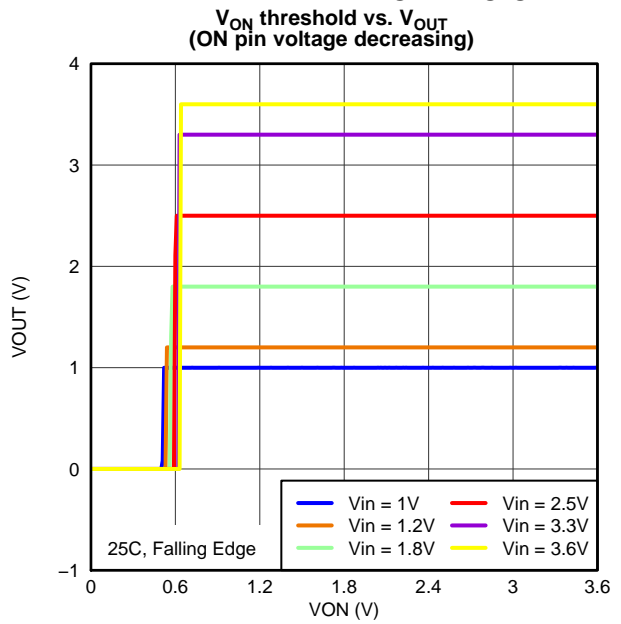

Figure 12.

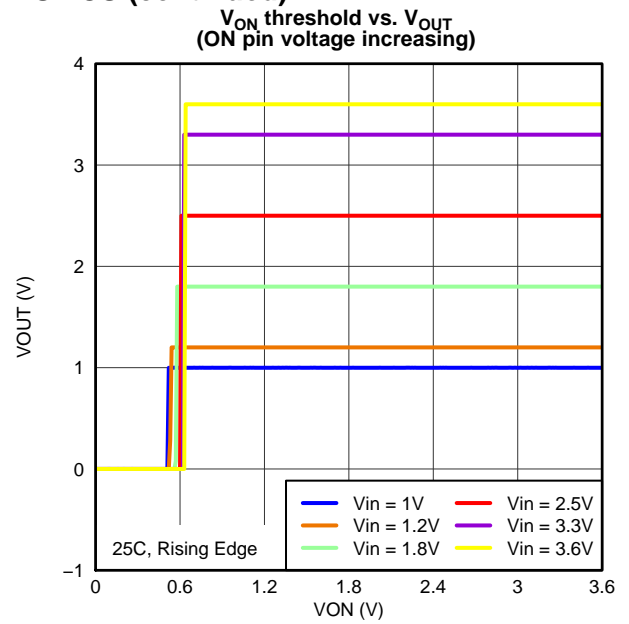

Figure 13.

TYPICAL SWITCHING CHARACTERISTICS

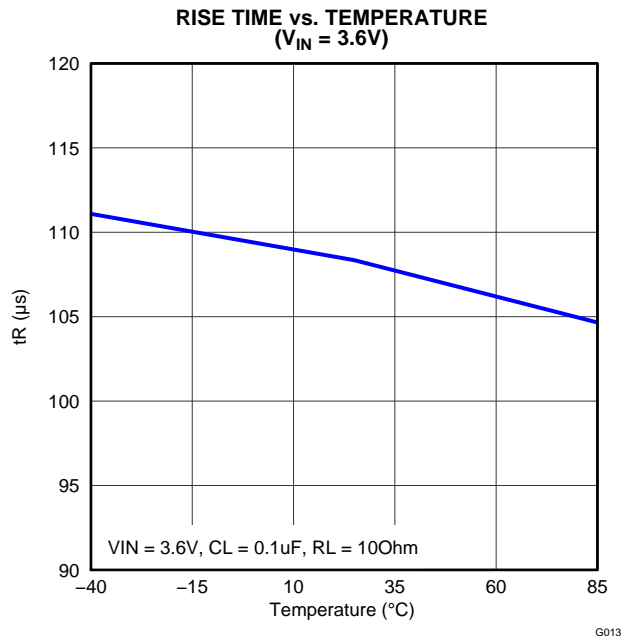

Figure 14.

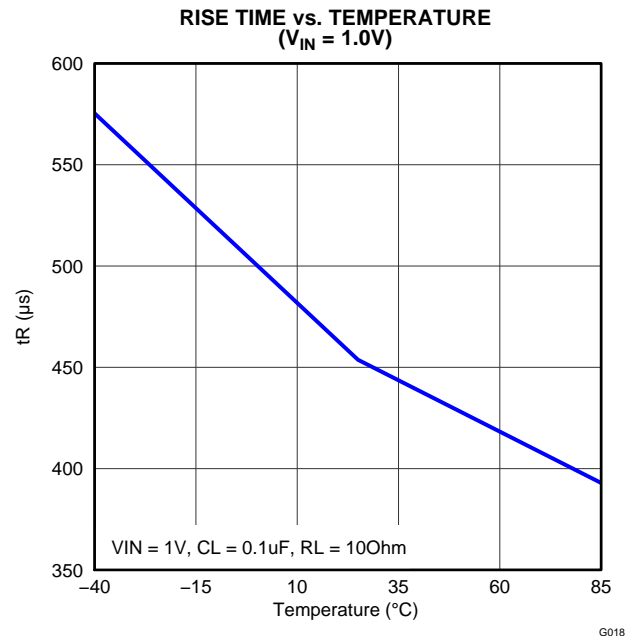

Figure 15.

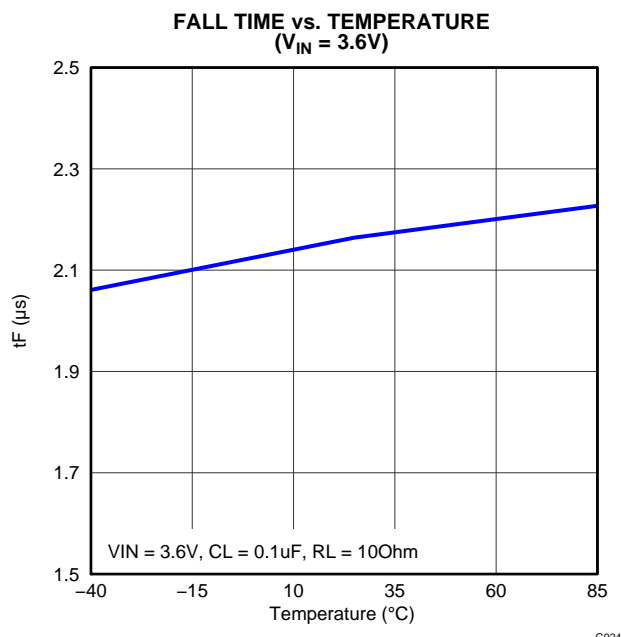

Figure 16.

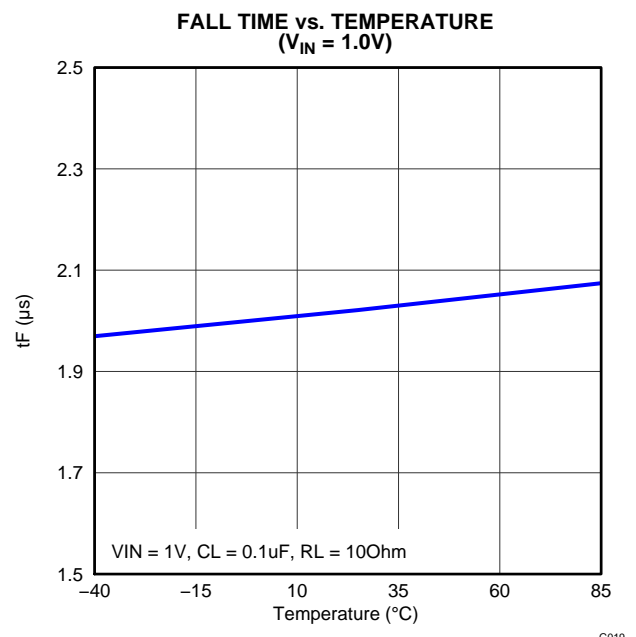

Figure 17.

TYPICAL SWITCHING CHARACTERISTICS (continued)

**TURN-ON TIME vs. TEMPERATURE
($V_{IN} = 3.6V$)**

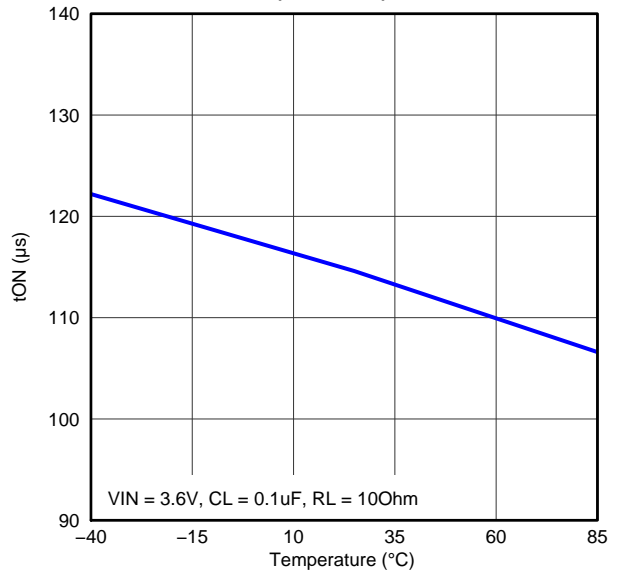

Figure 18.

**TURN-ON TIME vs. TEMPERATURE
($V_{IN} = 1.0V$)**

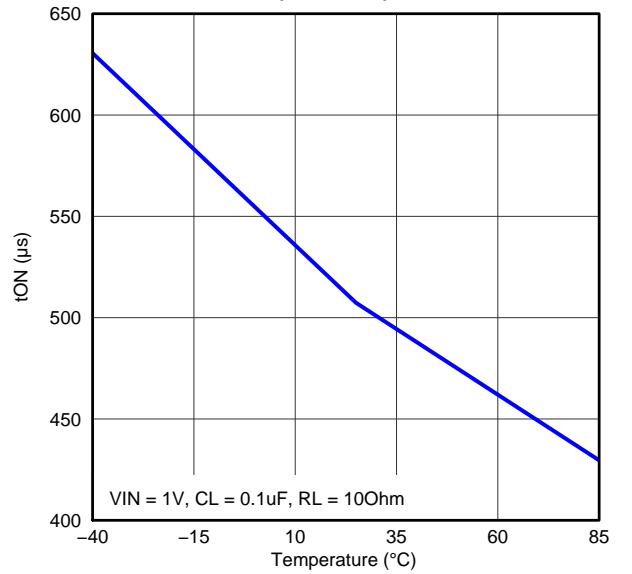

Figure 19.

**TURN-OFF TIME vs. TEMPERATURE
($V_{IN} = 3.6V$)**

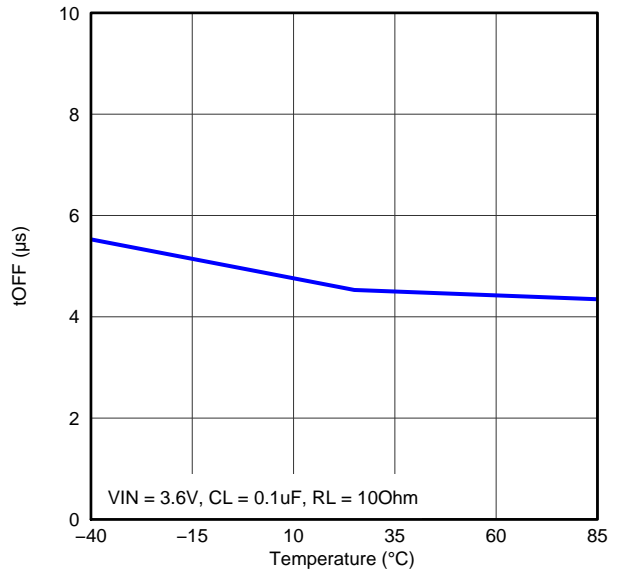

Figure 20.

**TURN-OFF TIME vs. TEMPERATURE
($V_{IN} = 1.0V$)**

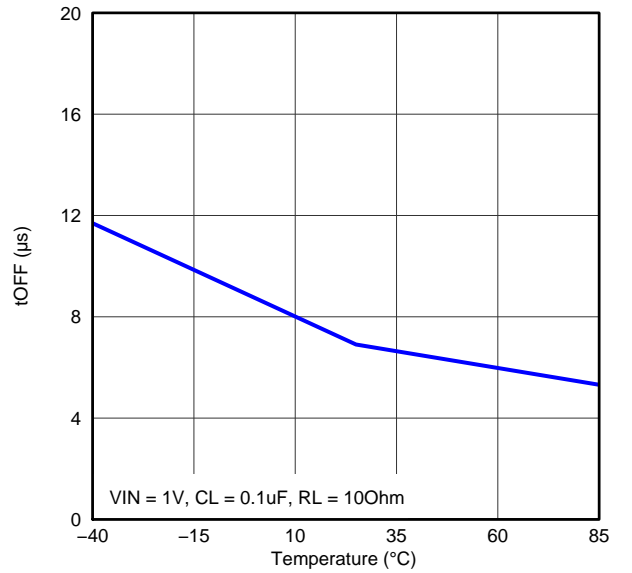

Figure 21.

TYPICAL SWITCHING CHARACTERISTICS (continued)

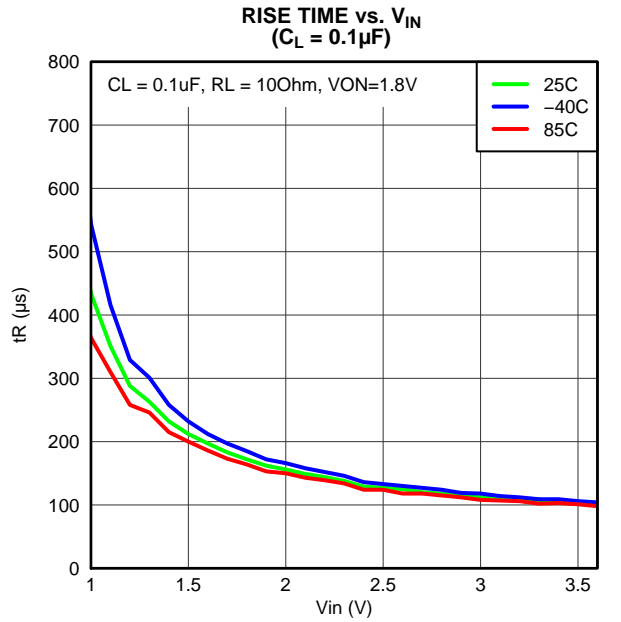

Figure 22.

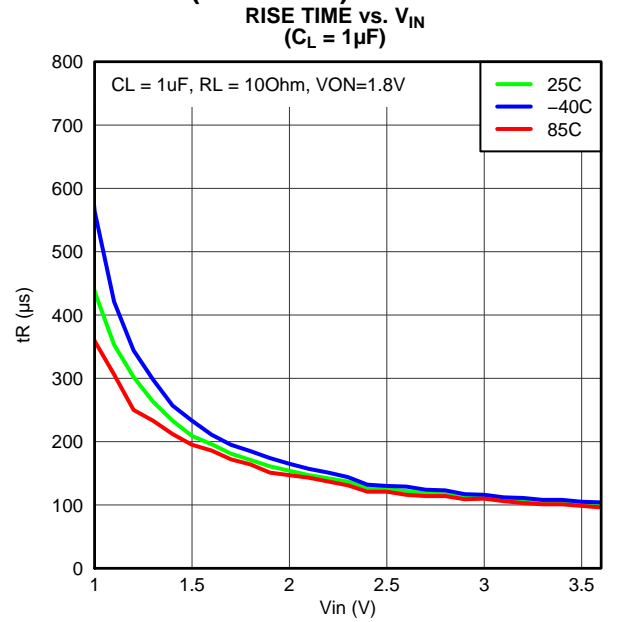

Figure 23.

TYPICAL SWITCHING SCOPE CAPTURES AT $T_A = 25^\circ\text{C}$

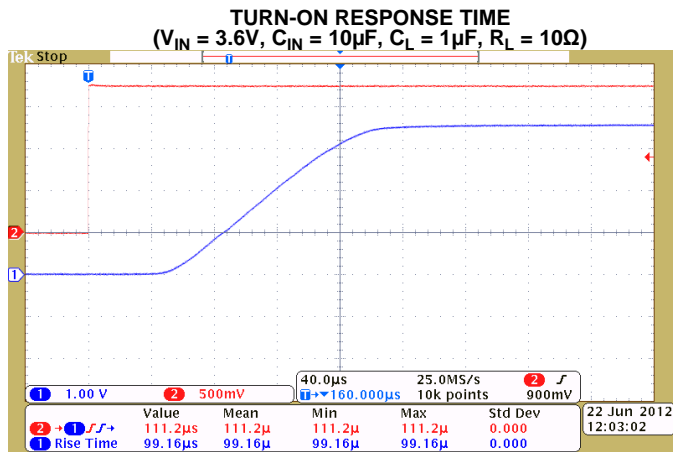

Figure 24.

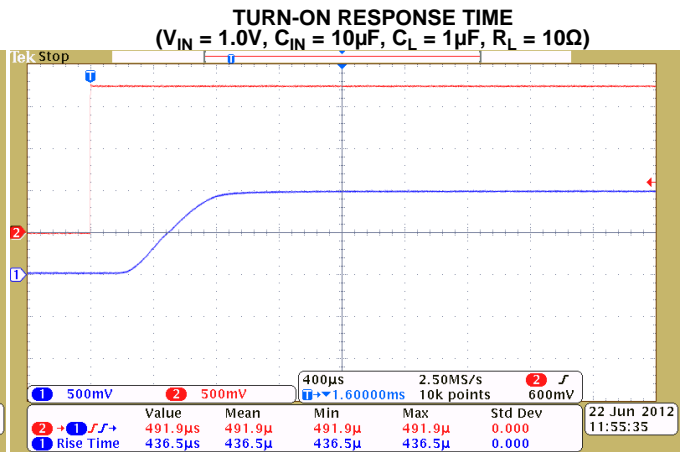

Figure 25.

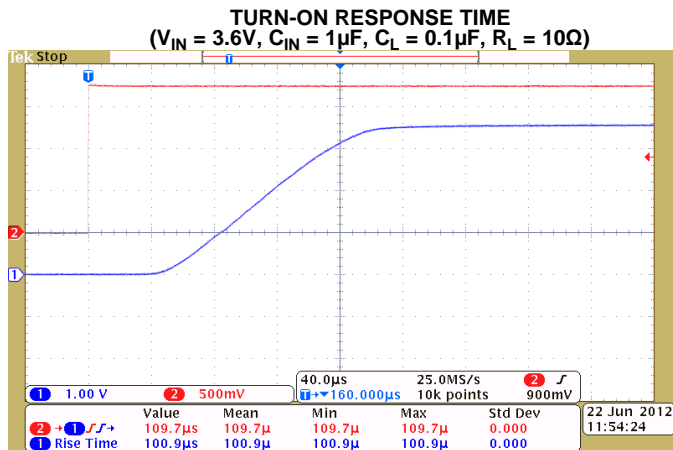

Figure 26.

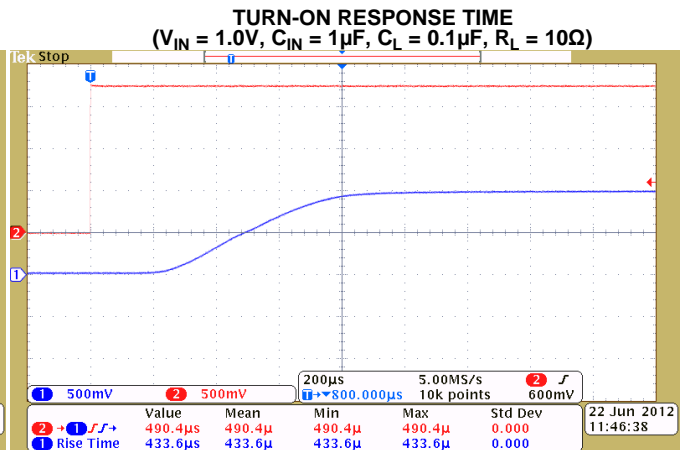

Figure 27.

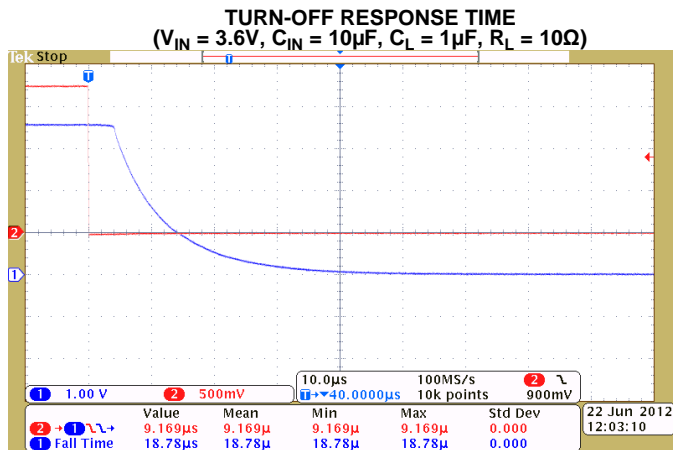

Figure 28.

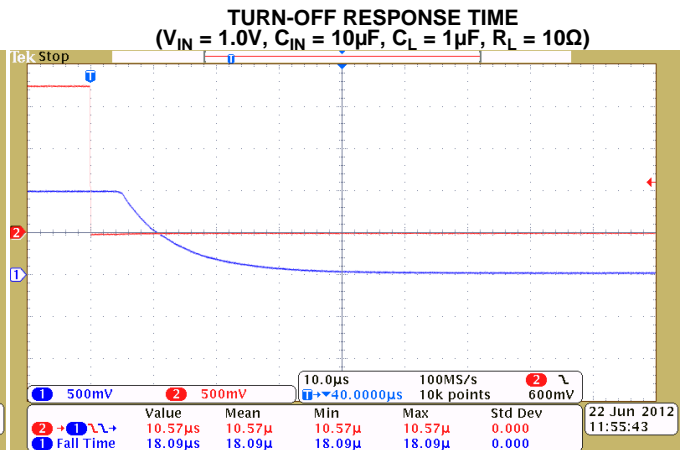

Figure 29.

TYPICAL SWITCHING SCOPE CAPTURES AT $T_A = 25^\circ\text{C}$ (continued)

TURN-OFF RESPONSE TIME
 $(V_{IN} = 3.6\text{V}, C_{IN} = 1\mu\text{F}, C_L = 0.1\mu\text{F}, R_L = 10\Omega)$

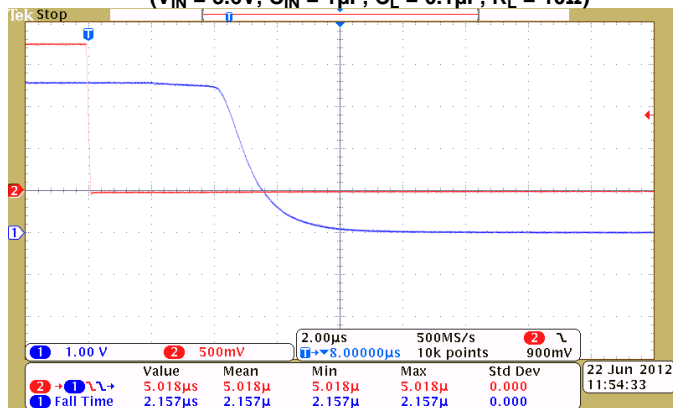

Figure 30.

TURN-OFF RESPONSE TIME
 $(V_{IN} = 1.0\text{V}, C_{IN} = 1\mu\text{F}, C_L = 0.1\mu\text{F}, R_L = 10\Omega)$

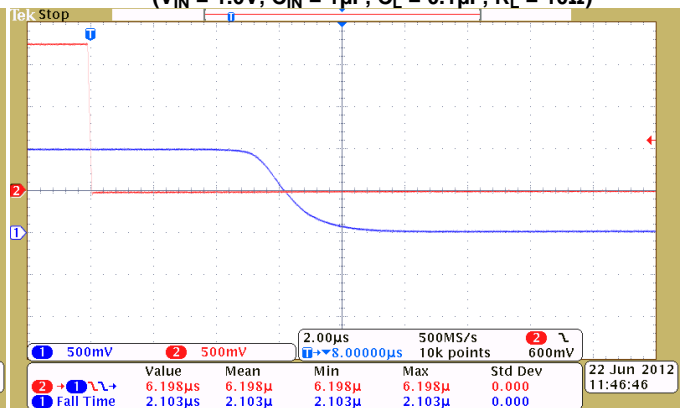

Figure 31.

APPLICATION INFORMATION

ON/OFF CONTROL

The ON pin controls the state of the switch. Asserting ON high enables the switch. ON is active high and has a low threshold making it capable of interfacing with low-voltage signals. The ON pin is compatible with standard GPIO logic threshold. It can be used with any microcontroller with 1.2-V or higher GPIOs.

INPUT CAPACITOR (OPTIONAL)

To limit the voltage drop on the input supply caused by transient inrush currents when the switch turns on into a discharged load capacitor or short-circuit, a capacitor can be placed between V_{IN} and GND. A 1- μ F ceramic capacitor, C_{IN} , placed close to the pins, is usually sufficient. Higher values of C_{IN} can be used to further reduce the voltage drop during high-current application. When switching heavy loads, it is recommended to have an input capacitor about 10 times higher than the output capacitor to avoid excessive voltage drop.

OUTPUT CAPACITOR (OPTIONAL)

Due to the integrated body diode of the PMOS switch, a C_{IN} greater than C_L is highly recommended. A C_L greater than C_{IN} can cause V_{OUT} to exceed V_{IN} when the system supply is removed. This could result in current flow through the body diode from V_{OUT} to V_{IN} . A C_{IN} to C_L ratio of at least 10 to 1 is recommended for minimizing V_{IN} dip caused by inrush currents during startup; however, a 10 to 1 ratio for capacitance is not required for proper functionality of the device. A ratio smaller than 10 to 1 (such as 1 to 1) could cause slightly more V_{IN} dip at turn on due to inrush currents.

BOARD LAYOUT

For best performance, all traces should be as short as possible. To be most effective, the input and output capacitors should be placed close to the device to minimize the effects that parasitic trace inductances may have on normal operation. Using wide traces for V_{IN} , V_{OUT} , and GND helps minimize the parasitic electrical effects along with minimizing the case to ambient thermal impedance.

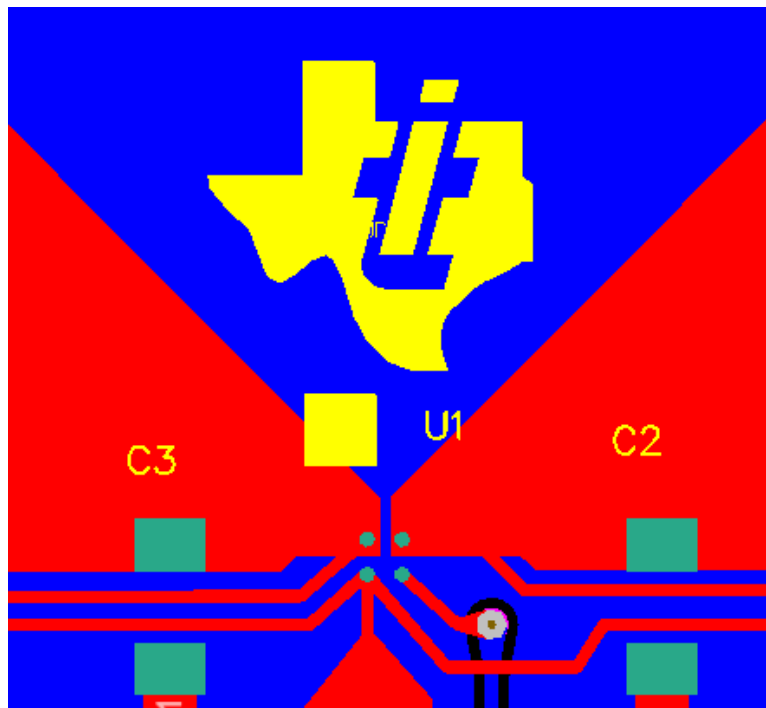

Figure 32. Layout

REVISION HISTORY

Changes from Revision A (August 2012) to Revision B	Page
• Updated FEATURES.	1
• Added Layout graphic.	14

PACKAGING INFORMATION

Orderable Device	Status (1)	Package Type	Package Drawing	Pins	Package Qty	Eco Plan (2)	Lead/Ball Finish	MSL Peak Temp (3)	Op Temp (°C)	Device Marking (4/5)	Samples
TPS22908YZTR	ACTIVE	DSBGA	YZT	4	3000	Green (RoHS & no Sb/Br)	SNAGCU	Level-1-260C-UNLIM	-40 to 85	(AT ~ ATF)	Samples
TPS22908YZTT	ACTIVE	DSBGA	YZT	4	250	Green (RoHS & no Sb/Br)	SNAGCU	Level-1-260C-UNLIM	-40 to 85	(AT ~ ATF)	Samples

(1) The marketing status values are defined as follows:

ACTIVE: Product device recommended for new designs.

LIFEBUY: TI has announced that the device will be discontinued, and a lifetime-buy period is in effect.

NRND: Not recommended for new designs. Device is in production to support existing customers, but TI does not recommend using this part in a new design.

PREVIEW: Device has been announced but is not in production. Samples may or may not be available.

OBSELETE: TI has discontinued the production of the device.

(2) Eco Plan - The planned eco-friendly classification: Pb-Free (RoHS), Pb-Free (RoHS Exempt), or Green (RoHS & no Sb/Br) - please check <http://www.ti.com/productcontent> for the latest availability information and additional product content details.

TBD: The Pb-Free/Green conversion plan has not been defined.

Pb-Free (RoHS): TI's terms "Lead-Free" or "Pb-Free" mean semiconductor products that are compatible with the current RoHS requirements for all 6 substances, including the requirement that lead not exceed 0.1% by weight in homogeneous materials. Where designed to be soldered at high temperatures, TI Pb-Free products are suitable for use in specified lead-free processes.

Pb-Free (RoHS Exempt): This component has a RoHS exemption for either 1) lead-based flip-chip solder bumps used between the die and package, or 2) lead-based die adhesive used between the die and leadframe. The component is otherwise considered Pb-Free (RoHS compatible) as defined above.

Green (RoHS & no Sb/Br): TI defines "Green" to mean Pb-Free (RoHS compatible), and free of Bromine (Br) and Antimony (Sb) based flame retardants (Br or Sb do not exceed 0.1% by weight in homogeneous material)

(3) MSL, Peak Temp. -- The Moisture Sensitivity Level rating according to the JEDEC industry standard classifications, and peak solder temperature.

(4) There may be additional marking, which relates to the logo, the lot trace code information, or the environmental category on the device.

(5) Multiple Device Markings will be inside parentheses. Only one Device Marking contained in parentheses and separated by a "~" will appear on a device. If a line is indented then it is a continuation of the previous line and the two combined represent the entire Device Marking for that device.

Important Information and Disclaimer:The information provided on this page represents TI's knowledge and belief as of the date that it is provided. TI bases its knowledge and belief on information provided by third parties, and makes no representation or warranty as to the accuracy of such information. Efforts are underway to better integrate information from third parties. TI has taken and continues to take reasonable steps to provide representative and accurate information but may not have conducted destructive testing or chemical analysis on incoming materials and chemicals. TI and TI suppliers consider certain information to be proprietary, and thus CAS numbers and other limited information may not be available for release.

In no event shall TI's liability arising out of such information exceed the total purchase price of the TI part(s) at issue in this document sold by TI to Customer on an annual basis.

TAPE AND REEL INFORMATION



QUADRANT ASSIGNMENTS FOR PIN 1 ORIENTATION IN TAPE



*All dimensions are nominal

Device	Package Type	Package Drawing	Pins	SPQ	Reel Diameter (mm)	Reel Width W1 (mm)	A0 (mm)	B0 (mm)	K0 (mm)	P1 (mm)	W (mm)	Pin1 Quadrant
TPS22908YZTT	DSBGA	YZT	4	250	180.0	8.4	0.99	0.99	0.69	4.0	8.0	Q1

TAPE AND REEL BOX DIMENSIONS



*All dimensions are nominal

Device	Package Type	Package Drawing	Pins	SPQ	Length (mm)	Width (mm)	Height (mm)
TPS22908YZTT	DSBGA	YZT	4	250	210.0	185.0	35.0

YZT (S-XBGA-N4)

DIE-SIZE BALL GRID ARRAY

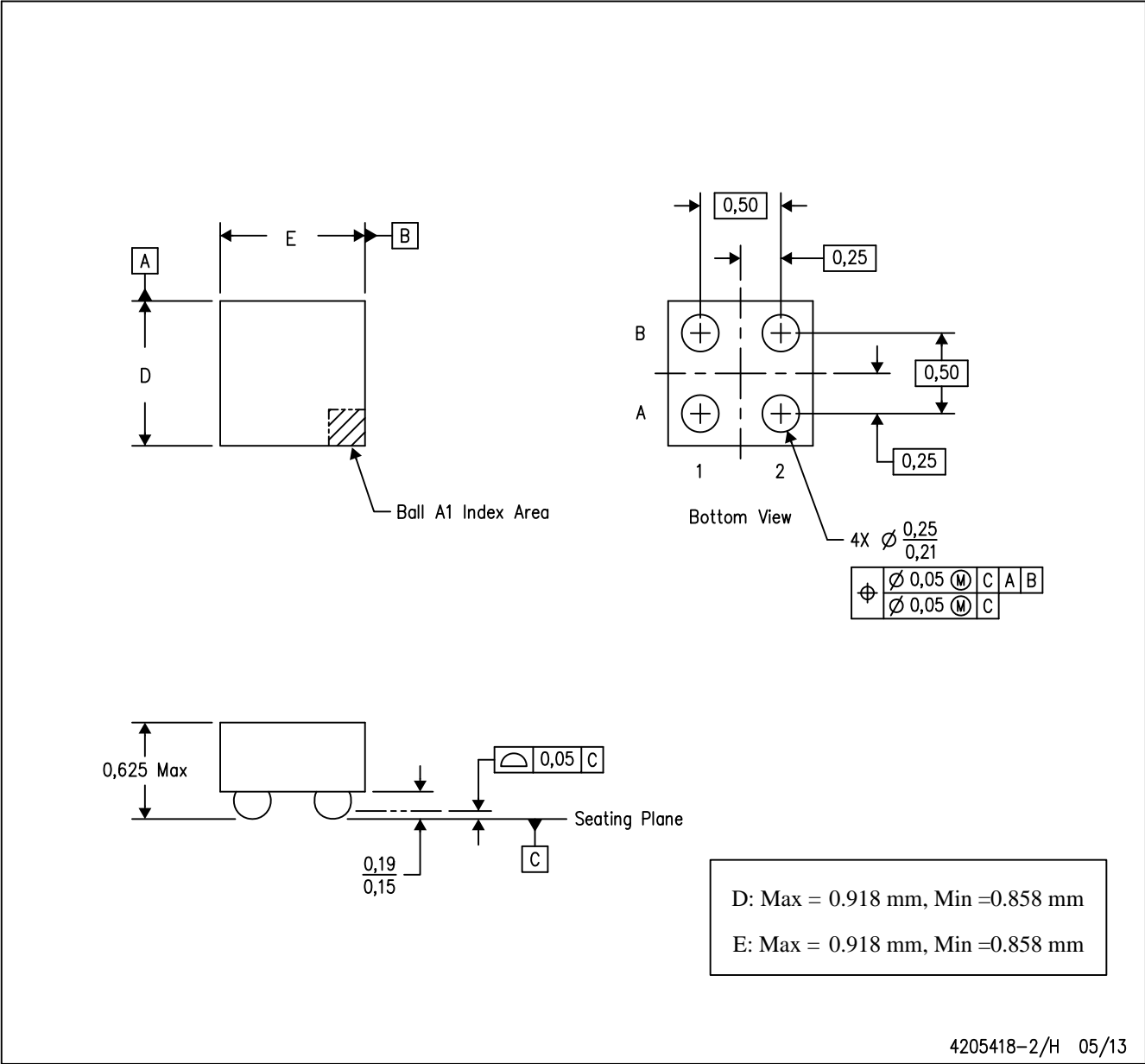

- NOTES:
- A. All linear dimensions are in millimeters. Dimensioning and tolerancing per ASME Y14.5M-1994.
 - B. This drawing is subject to change without notice.
 - C. NanoFree™ package configuration.

NanoFree is a trademark of Texas Instruments.

IMPORTANT NOTICE

Texas Instruments Incorporated and its subsidiaries (TI) reserve the right to make corrections, enhancements, improvements and other changes to its semiconductor products and services per JESD46, latest issue, and to discontinue any product or service per JESD48, latest issue. Buyers should obtain the latest relevant information before placing orders and should verify that such information is current and complete. All semiconductor products (also referred to herein as "components") are sold subject to TI's terms and conditions of sale supplied at the time of order acknowledgment.

TI warrants performance of its components to the specifications applicable at the time of sale, in accordance with the warranty in TI's terms and conditions of sale of semiconductor products. Testing and other quality control techniques are used to the extent TI deems necessary to support this warranty. Except where mandated by applicable law, testing of all parameters of each component is not necessarily performed.

TI assumes no liability for applications assistance or the design of Buyers' products. Buyers are responsible for their products and applications using TI components. To minimize the risks associated with Buyers' products and applications, Buyers should provide adequate design and operating safeguards.

TI does not warrant or represent that any license, either express or implied, is granted under any patent right, copyright, mask work right, or other intellectual property right relating to any combination, machine, or process in which TI components or services are used. Information published by TI regarding third-party products or services does not constitute a license to use such products or services or a warranty or endorsement thereof. Use of such information may require a license from a third party under the patents or other intellectual property of the third party, or a license from TI under the patents or other intellectual property of TI.

Reproduction of significant portions of TI information in TI data books or data sheets is permissible only if reproduction is without alteration and is accompanied by all associated warranties, conditions, limitations, and notices. TI is not responsible or liable for such altered documentation. Information of third parties may be subject to additional restrictions.

Resale of TI components or services with statements different from or beyond the parameters stated by TI for that component or service voids all express and any implied warranties for the associated TI component or service and is an unfair and deceptive business practice. TI is not responsible or liable for any such statements.

Buyer acknowledges and agrees that it is solely responsible for compliance with all legal, regulatory and safety-related requirements concerning its products, and any use of TI components in its applications, notwithstanding any applications-related information or support that may be provided by TI. Buyer represents and agrees that it has all the necessary expertise to create and implement safeguards which anticipate dangerous consequences of failures, monitor failures and their consequences, lessen the likelihood of failures that might cause harm and take appropriate remedial actions. Buyer will fully indemnify TI and its representatives against any damages arising out of the use of any TI components in safety-critical applications.

In some cases, TI components may be promoted specifically to facilitate safety-related applications. With such components, TI's goal is to help enable customers to design and create their own end-product solutions that meet applicable functional safety standards and requirements. Nonetheless, such components are subject to these terms.

No TI components are authorized for use in FDA Class III (or similar life-critical medical equipment) unless authorized officers of the parties have executed a special agreement specifically governing such use.

Only those TI components which TI has specifically designated as military grade or "enhanced plastic" are designed and intended for use in military/aerospace applications or environments. Buyer acknowledges and agrees that any military or aerospace use of TI components which have **not** been so designated is solely at the Buyer's risk, and that Buyer is solely responsible for compliance with all legal and regulatory requirements in connection with such use.

TI has specifically designated certain components as meeting ISO/TS16949 requirements, mainly for automotive use. In any case of use of non-designated products, TI will not be responsible for any failure to meet ISO/TS16949.

Products

Audio	www.ti.com/audio
Amplifiers	amplifier.ti.com
Data Converters	dataconverter.ti.com
DLP® Products	www.dlp.com
DSP	dsp.ti.com
Clocks and Timers	www.ti.com/clocks
Interface	interface.ti.com
Logic	logic.ti.com
Power Mgmt	power.ti.com
Microcontrollers	microcontroller.ti.com
RFID	www.ti-rfid.com
OMAP Applications Processors	www.ti.com/omap
Wireless Connectivity	www.ti.com/wirelessconnectivity

Applications

Automotive and Transportation	www.ti.com/automotive
Communications and Telecom	www.ti.com/communications
Computers and Peripherals	www.ti.com/computers
Consumer Electronics	www.ti.com/consumer-apps
Energy and Lighting	www.ti.com/energy
Industrial	www.ti.com/industrial
Medical	www.ti.com/medical
Security	www.ti.com/security
Space, Avionics and Defense	www.ti.com/space-avionics-defense
Video and Imaging	www.ti.com/video

TI E2E Community

e2e.ti.com

AMEYA360

Components Supply Platform

Authorized Distribution Brand :



Website :

Welcome to visit www.ameya360.com

Contact Us :

➤ Address :

401 Building No.5, JiuGe Business Center, Lane 2301, Yishan Rd
Minhang District, Shanghai , China

➤ Sales :

Direct +86 (21) 6401-6692

Email amall@ameya360.com

QQ 800077892

Skype [ameyasales1](#) [ameyasales2](#)

➤ Customer Service :

Email service@ameya360.com

➤ Partnership :

Tel +86 (21) 64016692-8333

Email mkt@ameya360.com