

44 V, 5.5 A, quad power half-bridge

Datasheet - production data

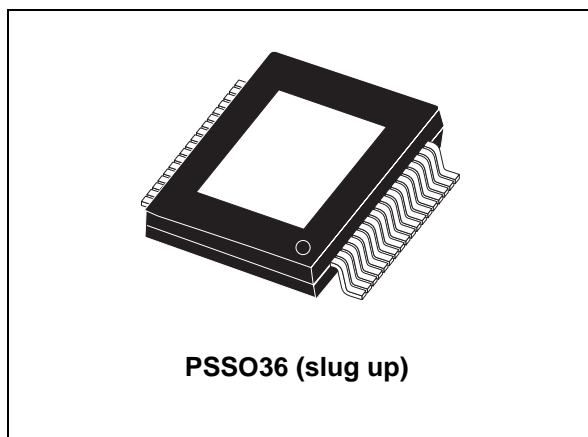

Features

- Minimum input/output pulse width distortion
- 150 mΩ R_{dsON} complementary DMOS output stage
- CMOS compatible logic inputs
- Thermal protection
- Thermal warning output
- Undervoltage protection
- No power-on, power-off sequence required

Description

The STA510F is a monolithic, quad, half-bridge stage in multipower BCD technology. The device can be used as dual-bridge or reconfigured, by connecting the CONFIG pin to the Vdd pin, as single-bridge with double current capability, and as half-bridge (binary mode).

The device is particularly designed to make the output stage of a stereo all-digital high-efficiency (FFX) amplifier capable of delivering 100 W + 100 W output power into 6 Ω loads with THD = 10% and $V_{CC} = 36$ V. In single BTL configuration the device can deliver 200 W into a 3 Ω load with THD = 10% and $V_{CC} = 36$ V.

The device is fully compatible with the FFX[®] driver device.

The input pins have a threshold proportional to V_L pin voltage.

Table 1. Device summary

Order code	Operating temp. range	Package	Packing
STA510F	0° to 70° C	PSSO36 (slug up)	Tube
STA510FTR	0° to 70° C	PSSO36 (slug up)	Tape & reel

Contents

1	Application diagram	3
2	Pin description	4
3	Electrical specifications	6
3.1	Absolute maximum ratings	6
3.2	Thermal data	6
3.3	Electrical specifications	6
4	Characterization curves	12
5	Output filter	19
5.1	Theoretical filter	19
5.2	Optimized filter	20
6	Package information	22
7	Trademarks and other acknowledgments	24
8	Revision history	25

1 Application diagram

Figure 1. Typical application

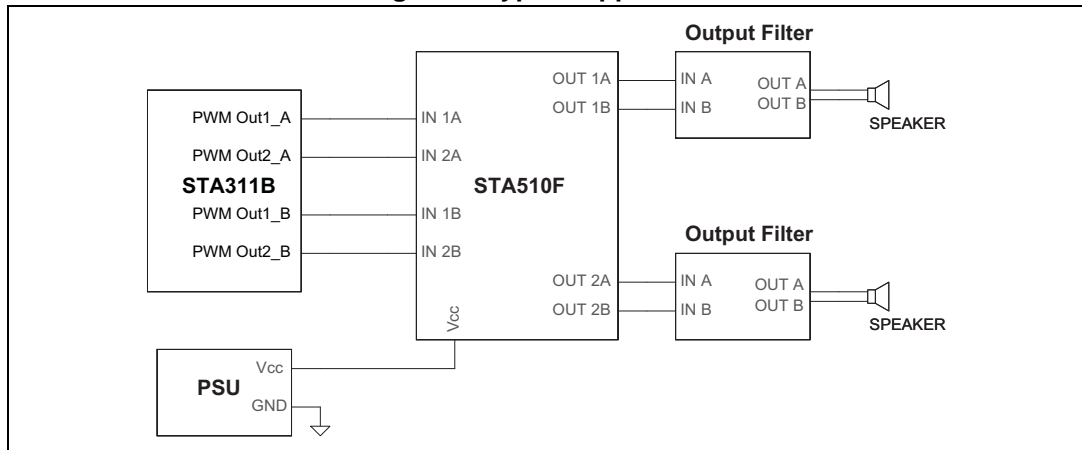

2 Pin description

Figure 2. Pin connections (top view)

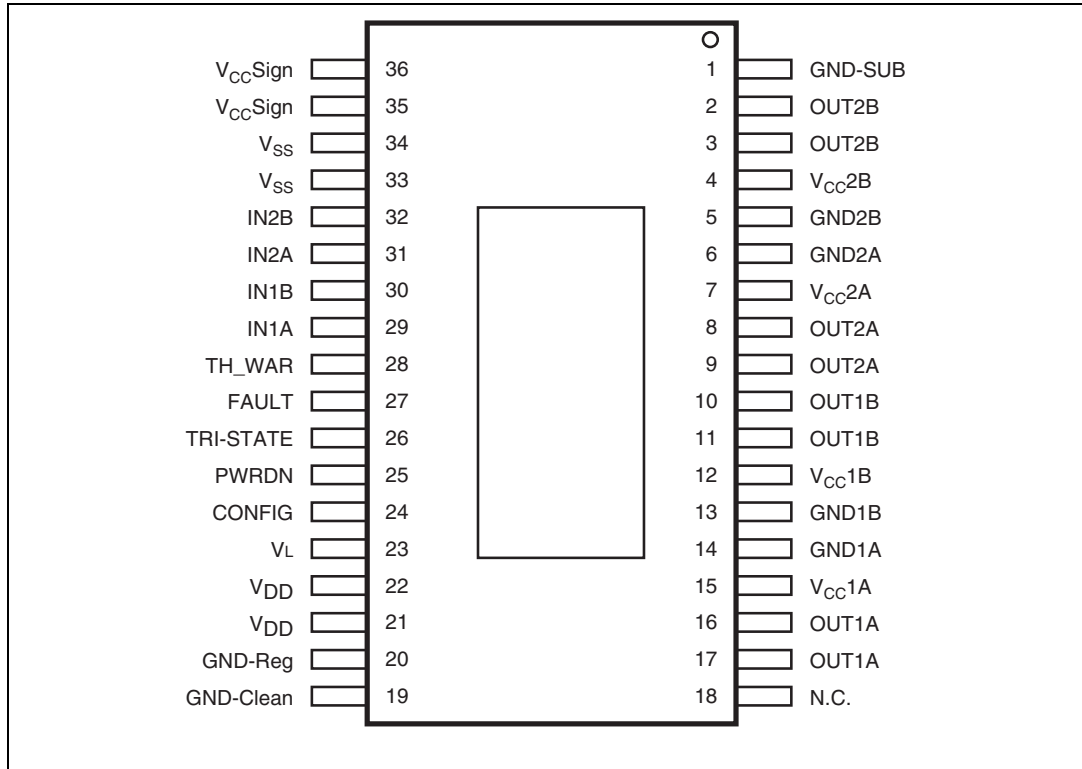

Table 2. Pin list

Pin	Name	Description
1	GND-SUB	Substrate ground
2, 3	OUT2B	Output half-bridge 2B
4	V _{CC} 2B	Positive supply
5	GND2B	Negative supply
6	GND2A	Negative supply
7	V _{CC} 2A	Positive supply
8, 9	OUT2A	Output half-bridge 2A
10, 11	OUT1B	Output half-bridge 1B
12	V _{CC} 1B	Positive supply
13	GND1B	Negative supply
14	GND1A	Negative supply
15	V _{CC} 1A	Positive supply
16, 17	OUT1A	Output half-bridge 1A
18	NC	Not connected

Table 2. Pin list (continued)

Pin	Name	Description
19	GND-clean	Logical ground
20	GND-Reg	Ground for regulator Vdd
21, 22	Vdd	5-V regulator referred to ground
23	V _L	High logical state setting voltage
24	CONFIG	Configuration
25	PWRDN	Standby
26	TRI-STATE	Hi-Z
27	FAULT	Fault pin advisor
28	TH-WAR	Thermal warning advisor
29	IN1A	Input of half-bridge 1A
30	IN1B	Input of half-bridge 1B
31	IN2A	Input of half-bridge 2A
32	IN2B	Input of half-bridge 2B
33, 34	Vss	5-V regulator referred to +V _{CC}
35, 36	VCCSIGN	Signal positive supply

Table 3. Pin values

Pin	Logical value	Device status
FAULT ⁽¹⁾	0	Fault detected (short-circuit, or thermal)
	1	Normal operation
TRI-STATE	0	All power stages in Hi-Z state
	1	Normal operation
PWRDN	0	Low-power mode
	1	Normal operation
THWAR ⁽¹⁾	0	Temperature of the IC = 130° C
	1	Normal operation
CONFIG ⁽²⁾	0	Normal operation
	1	OUT1A = OUT1B, OUT2A = OUT2B (IF IN1A = IN1B and IN2A = IN2B)

1. The pin is open collector. To have the high logic value, it needs a pull-up resistor.
2. CONFIG = 1 means connect pin 24 (CONFIG) to pins 21, 22 (Vdd).

3 Electrical specifications

3.1 Absolute maximum ratings

Table 4. Absolute maximum ratings

Symbol	Parameter	Value	Unit
V_{CC}	DC supply voltage (pin 4, 7, 12, 15)	44	V
V_{max}	Maximum voltage on pins 23 to 32	5.5	V
ESD	Max ESD on pins (HBM)	±1000	V
T_{op}	Operating temperature range	0 to 70	°C
T_{stg}, T_j	Storage and junction temperature	-40 to 150	°C

3.2 Thermal data

Table 5. Thermal data

Symbol	Parameter	Min.	Typ.	Max.	Unit
T_{j-case}	Thermal resistance junction to case (thermal pad)		1	2.5	°C/W
T_{jSD}	Thermal shut-down junction temperature		150		°C
T_{wam}	Thermal warning temperature		130		°C
t_{hSD}	Thermal shutdown hysteresis		25		°C

3.3 Electrical specifications

The results in [Table 6](#) below are given for the conditions: $V_L = 3.3$ V, $V_{CC} = 37$ V and $T = 25$ °C unless otherwise specified.

Table 6. Electrical specifications

Symbol	Parameter	Condition	Min.	Typ.	Max.	Unit
R_{dsON}	Power P-channel/N-channel MOSFET RdsON	$I_d = 1$ A		150	200	mΩ
I_{dss}	Power P-channel/N-channel leakage current				100	μA
g_N	Power P-channel RdsON matching	$I_d = 1$ A	95			%
g_P	Power N-channel RdsON matching	$I_d = 1$ A	95			%
Dt_s	Low current deadtime (static)	see test circuit Figure 3		10	20	ns
Dt_d	High current deadtime (dynamic)	$L = 22$ μH, $C = 470$ nF, $R_L = 8$ Ω, $I_d = 4.5$ A, see test circuit Figure 4			50	ns
t_{dON}	Turn-on delay time	Resistive load			100	ns

Table 6. Electrical specifications (continued)

Symbol	Parameter	Condition	Min.	Typ.	Max.	Unit
$t_{d\ OFF}$	Turn-off delay time	Resistive load			100	ns
t_r	Rise time	Resistive load, as Figure 4			25	ns
t_f	Fall time	Resistive load, as Figure 4			25	ns
V_{CC}	Supply voltage operating voltage		10		40	V
$V_{IN-High}$	High level input voltage		$V_L/2 + 300\text{ mV}$			V
V_{IN-Low}	Low level input voltage				$V_L/2 - 300\text{ mV}$	V
I_{IN-H}	High level input current	Pin voltage = V_L		1		μA
I_{IN-L}	Low level input current	Pin voltage = 0.3 V		1		μA
$I_{PWRDN-H}$	High level PWRDN pin input current	$V_L = 3.3\text{ V}$		35		μA
V_{Low}	Low logical state voltage (pins PWRDN, TRISTATE) (see Table 7)	$V_L = 3.3\text{ V}$			0.8	V
V_{High}	High logical state voltage (pins PWRDN, TRISTATE) (see Table 7)	$V_L = 3.3\text{ V}$	1.7			V
$I_{VCC-PWRDN}$	Supply current from V_{CC} in power down	PWRDN = 0			3	mA
I_{FAULT}	Output current pins FAULT -TH-WARN when FAULT CONDITIONS	$V_{PIN} = 3.3\text{ V}$		1		mA
$I_{VCC-hiz}$	Supply current from V_{CC} in tri-state	Pin TRI-STATE = 0		22		mA
I_{VCC}	Supply current from V_{CC} in operation both channel switching)	Input pulse width duty cycle = 50%, switching frequency = 384 kHz, no LC filters;		70		mA
I_{OUT-SH}	Overcurrent protection threshold I_{SC} (short-circuit current limit)		5.5	7	9	A
V_{UV}	Undervoltage protection threshold			7		V
t_{pw_min}	Output minimum pulse width	No load	25		40	ns

Table 7. V_{Low} , V_{High} threshold variation with V_L

V_L	$V_{Low} \text{ max}$	$V_{High} \text{ min}$	Unit
2.7	0.7	1.5	V
3.3	0.8	1.7	V
5	0.85	1.85	V

Table 8. Logic truth table

TRI-STATE	INxA	INxB	Q1	Q2	Q3	Q4	Output mode
0	x	x	OFF	OFF	OFF	OFF	Hi-Z
1	0	0	OFF	OFF	ON	ON	DUMP
1	0	1	OFF	ON	ON	OFF	NEGATIVE
1	1	0	ON	OFF	OFF	ON	POSITIVE
1	1	1	ON	ON	OFF	OFF	Not used

Figure 3. Test circuit for low current deadtime

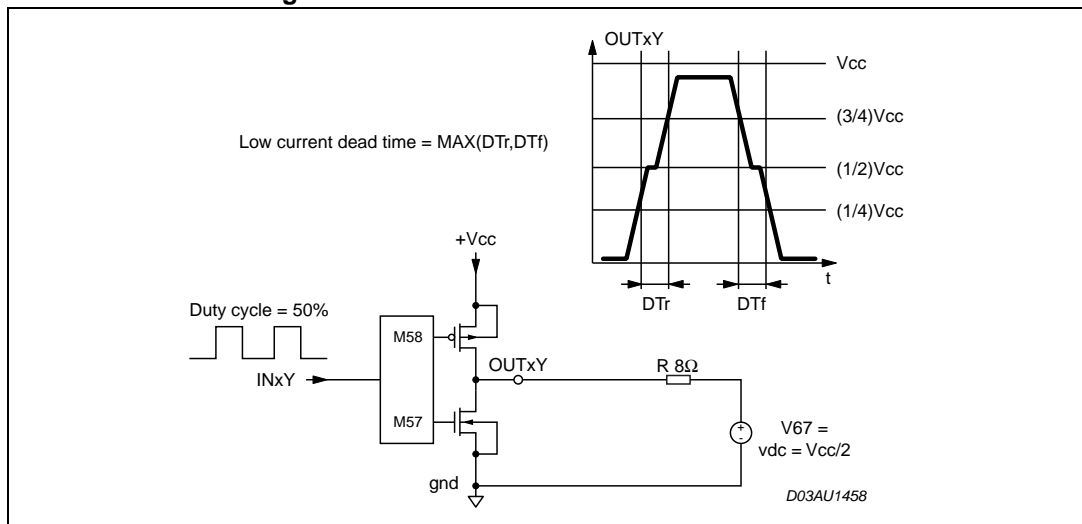

Figure 4. Test circuit for high current deadtime

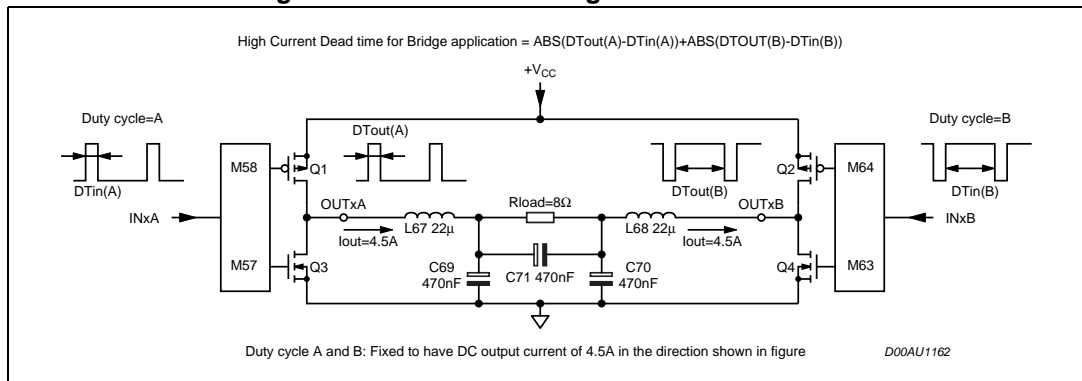

Figure 5. STA311B connections with STA510F

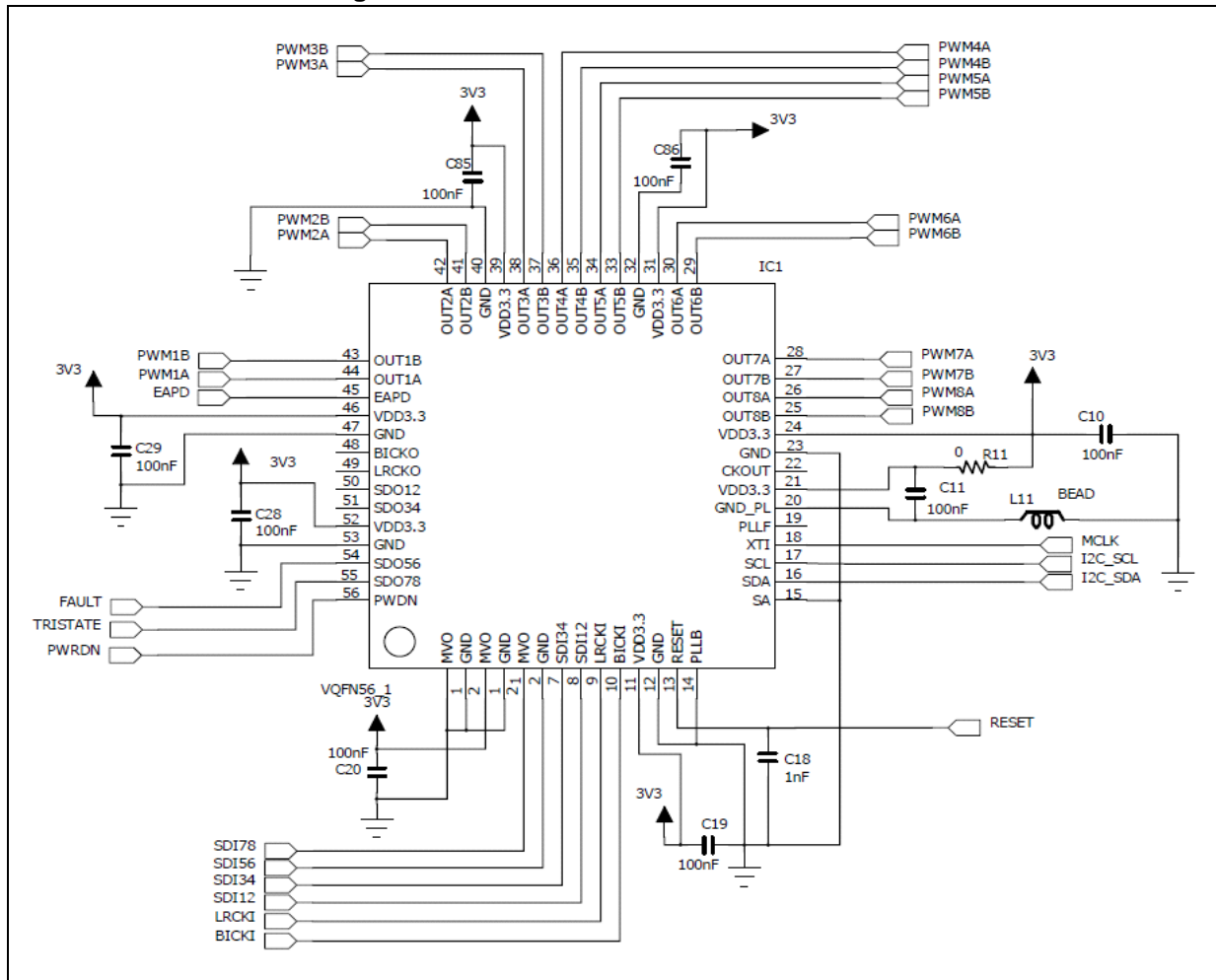

Figure 6. Typical stereo BTL configuration

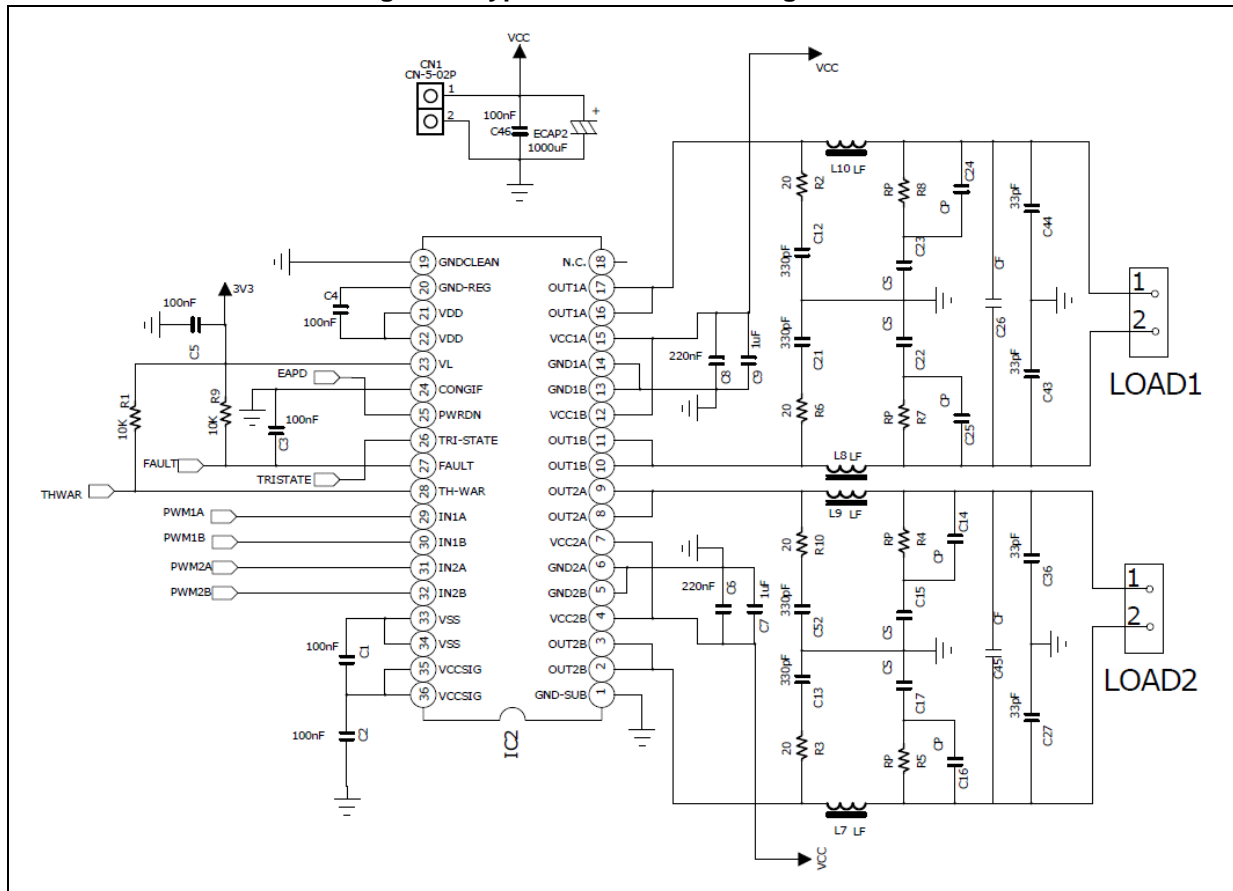
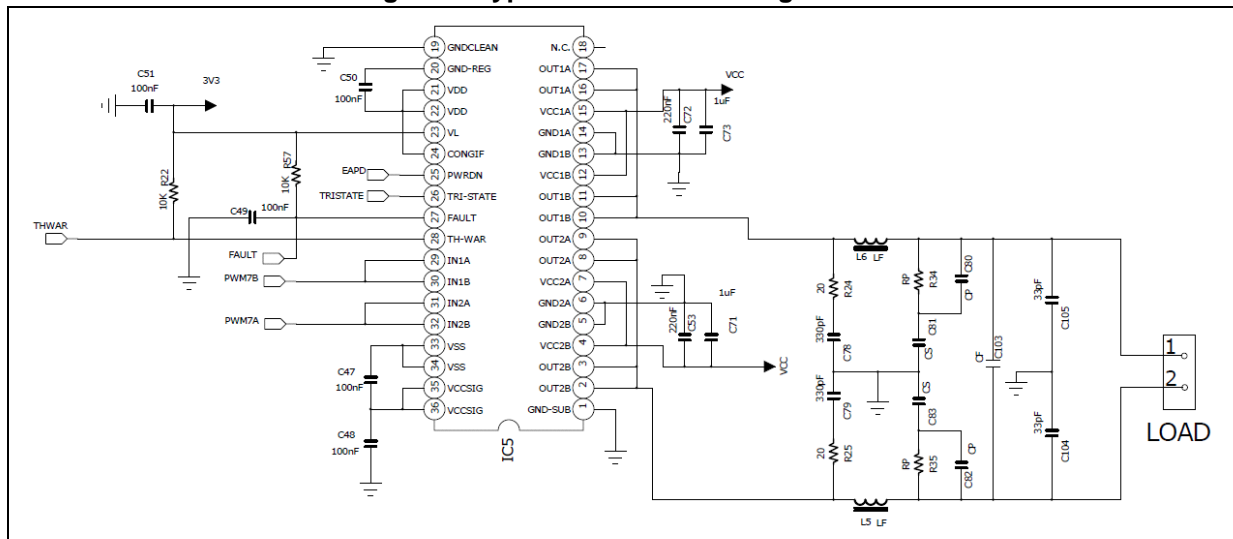

Figure 7. Typical mono BTL configuration



4 Characterization curves

Figure 9. THD+N vs. P_{OUT} 36 V 6 Ω BTL time slot 13, 0x03 = BB

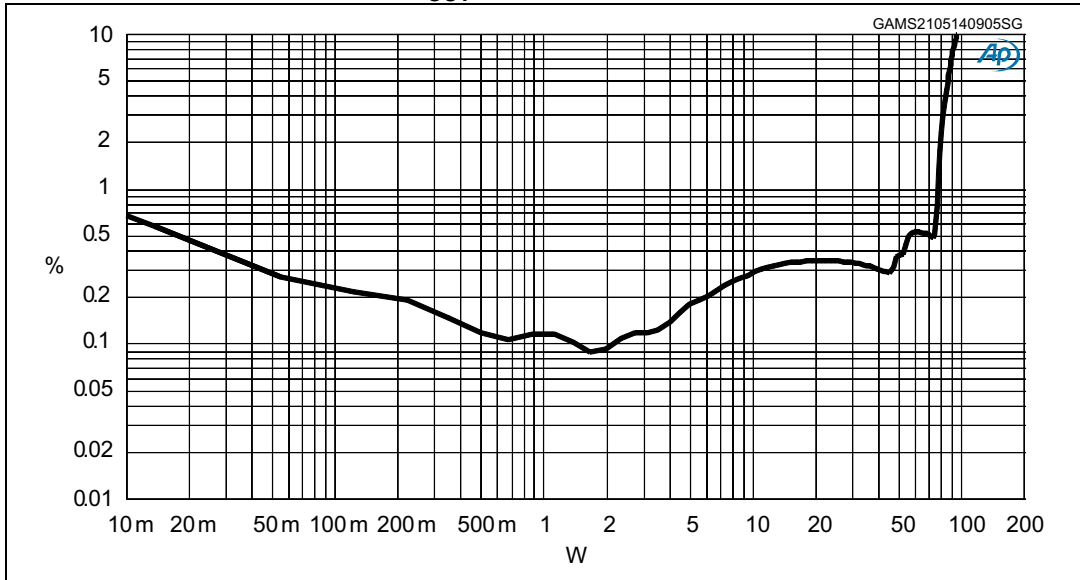

Figure 10. THD+N vs. P_{OUT} 36 V 3 Ω SE

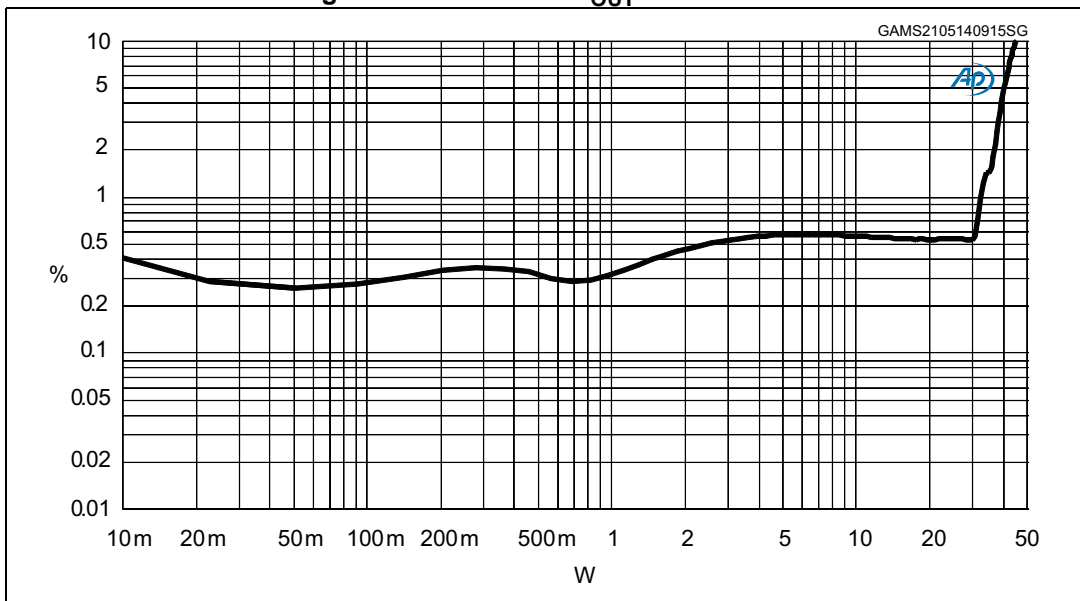

Figure 11. THD+N vs. P_{OUT} 36V 3 Ω mono BTL

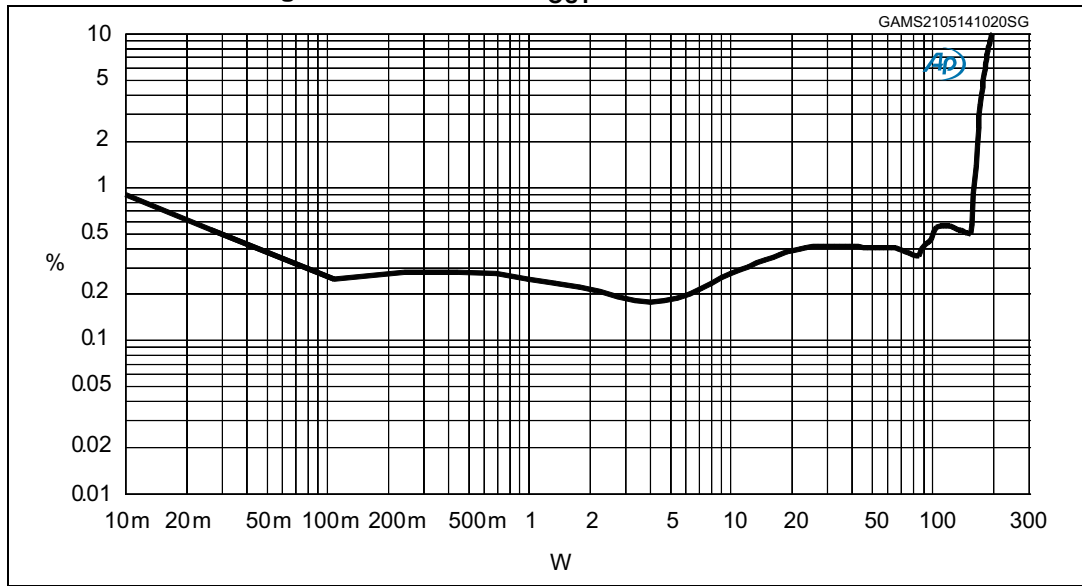

Figure 12. P_{OUT} vs. V_{CC} 6 Ω BTL

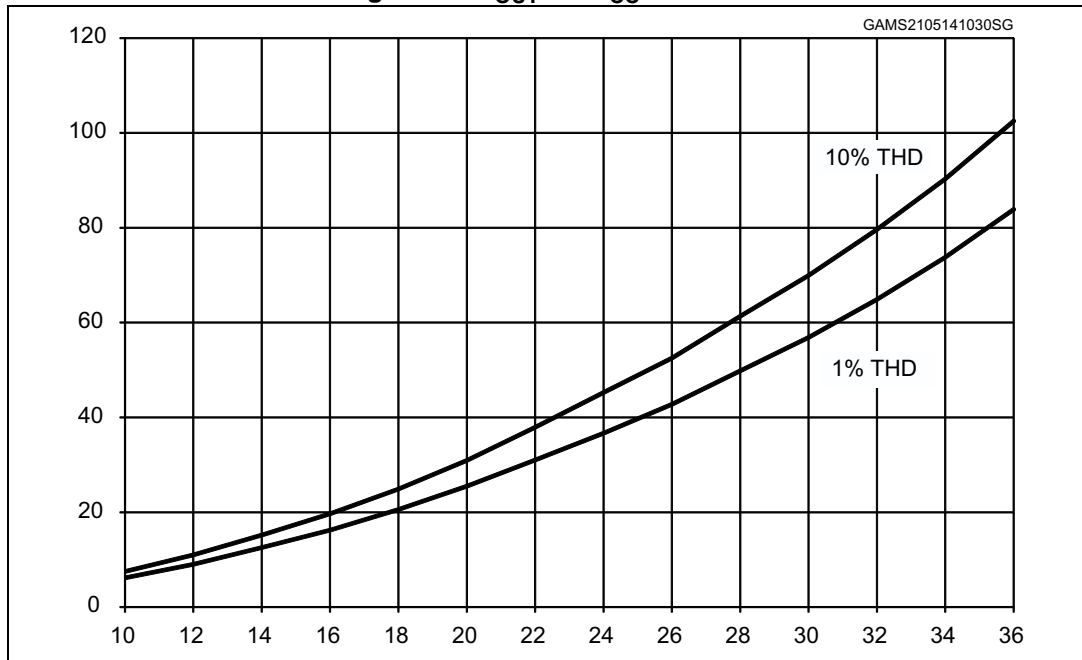

Figure 13. P_{OUT} vs. V_{CC} 3 Ω SE

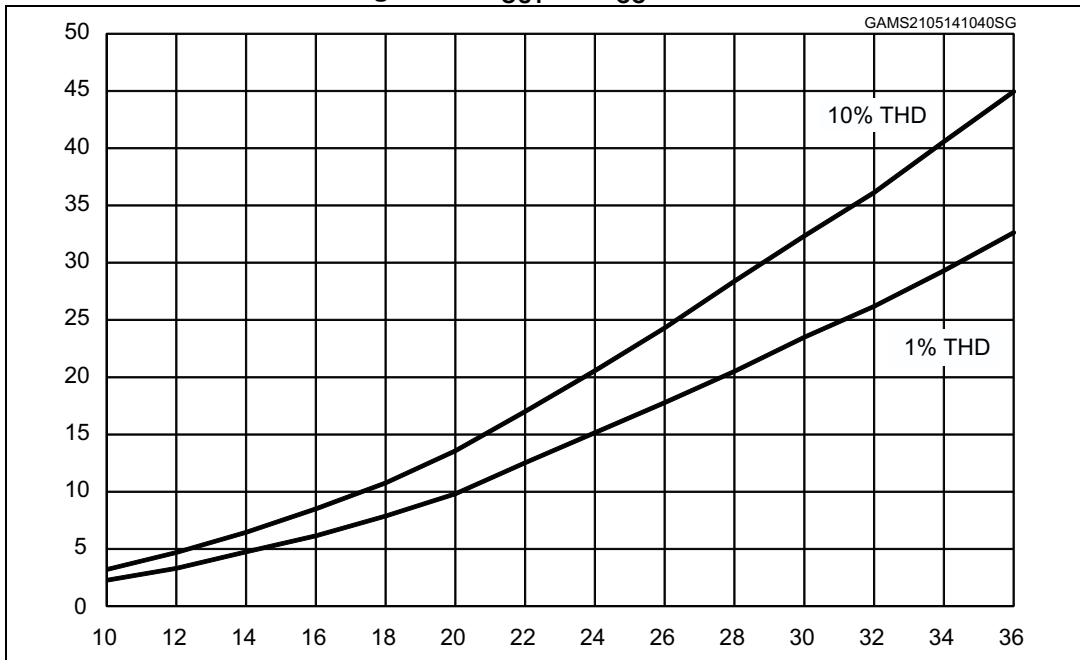

Figure 14. P_{OUT} vs. V_{CC} 3 Ω mono BTL

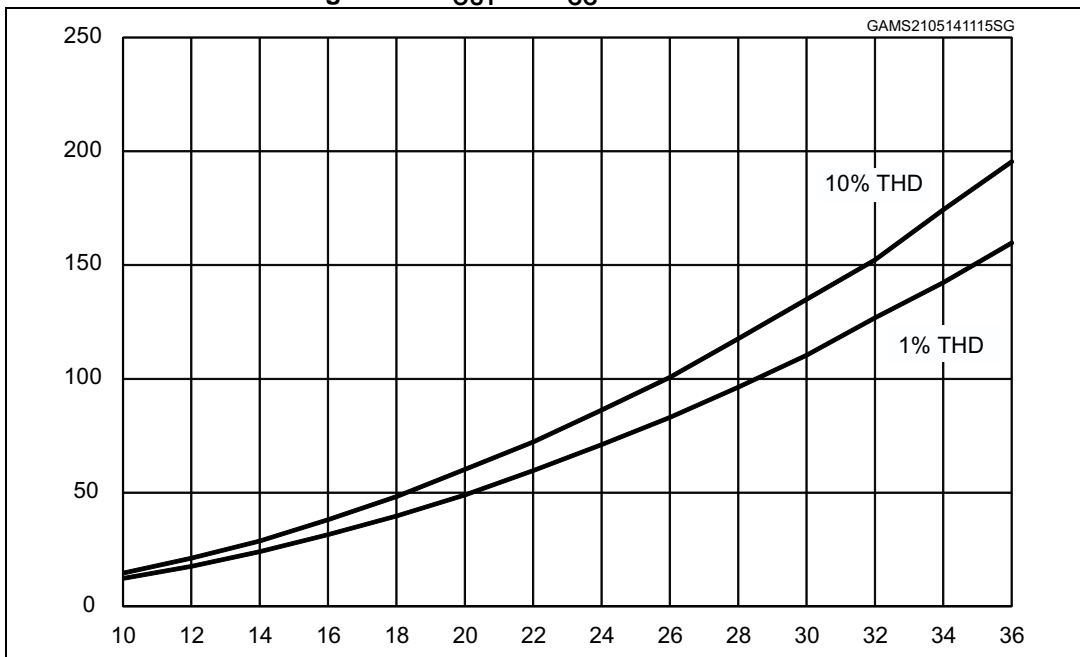

Figure 15. FFT 6 Ω BTL -6dBFs

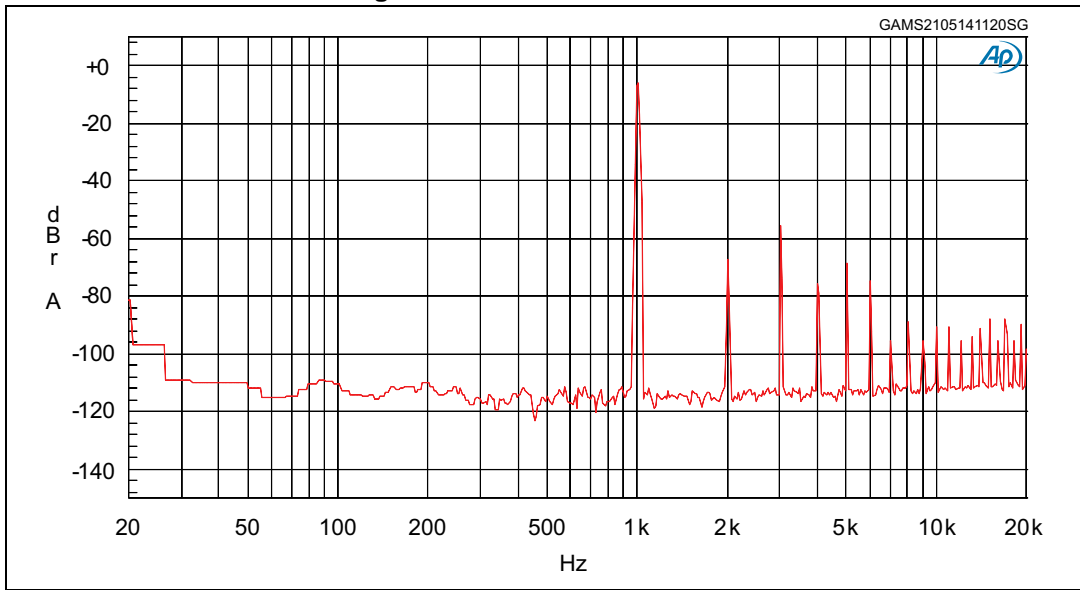

Figure 16. FFT 6 Ω BTL -60dBFs

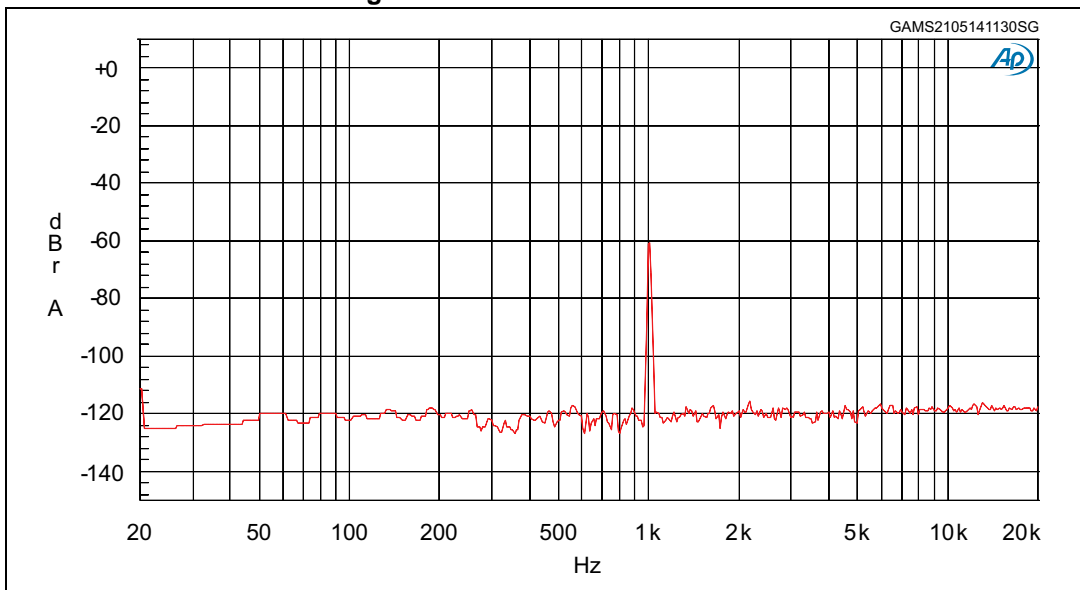

Figure 17. FFT 3 Ω SE -6dBFs

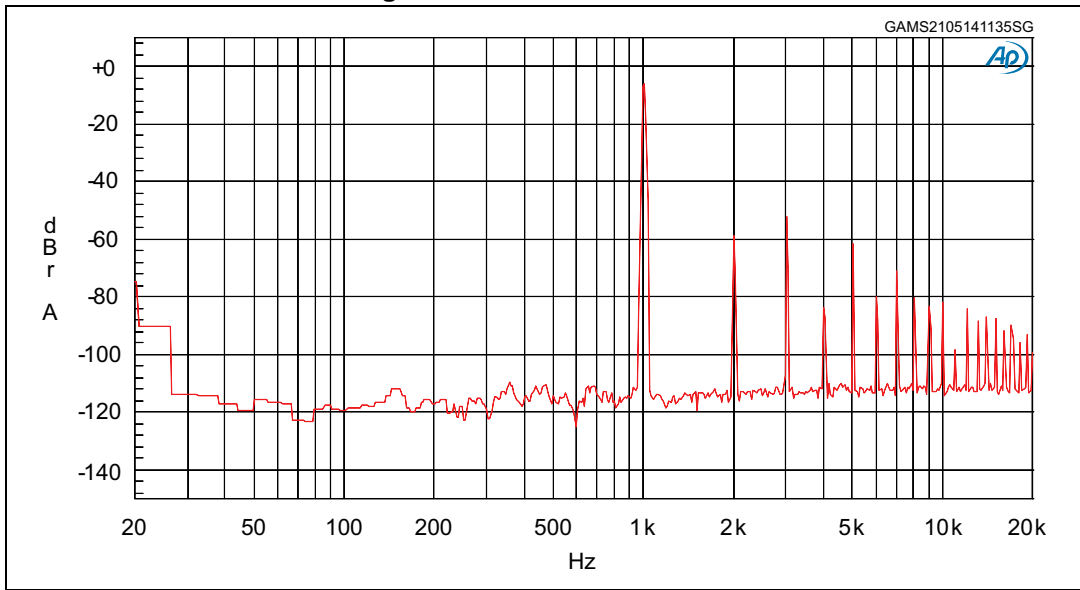

Figure 18. FFT 3 Ω SE -60dBFs

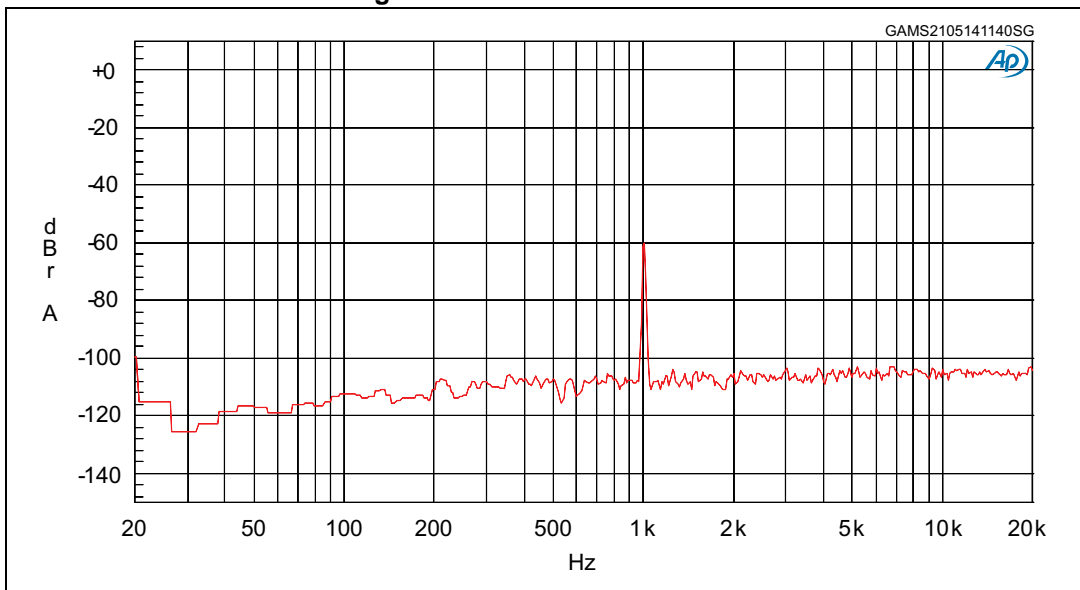

Figure 19. FFT 3 Ω mono BTL -6dBFs

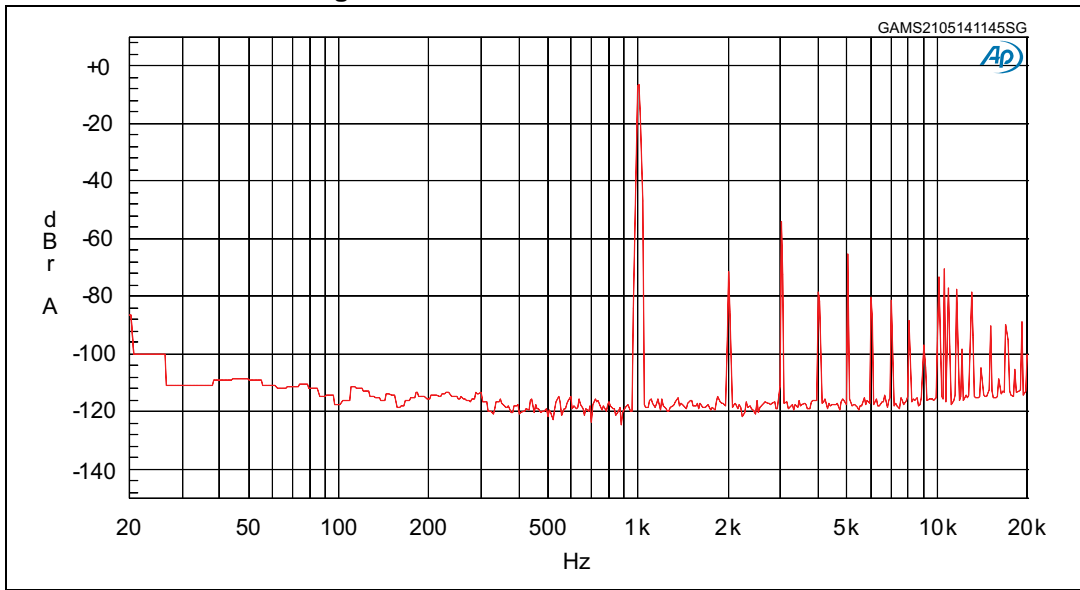

Figure 20. FFT 3 Ω mono BTL -60dBFs

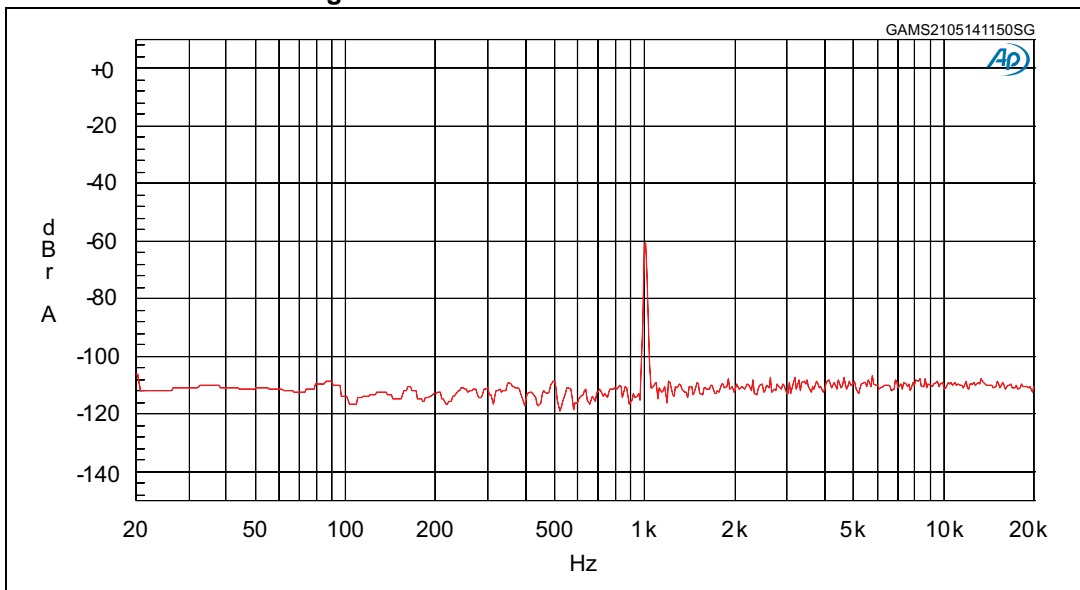

Figure 21. Crosstalk 36 V 6 BTL Ω 1 W

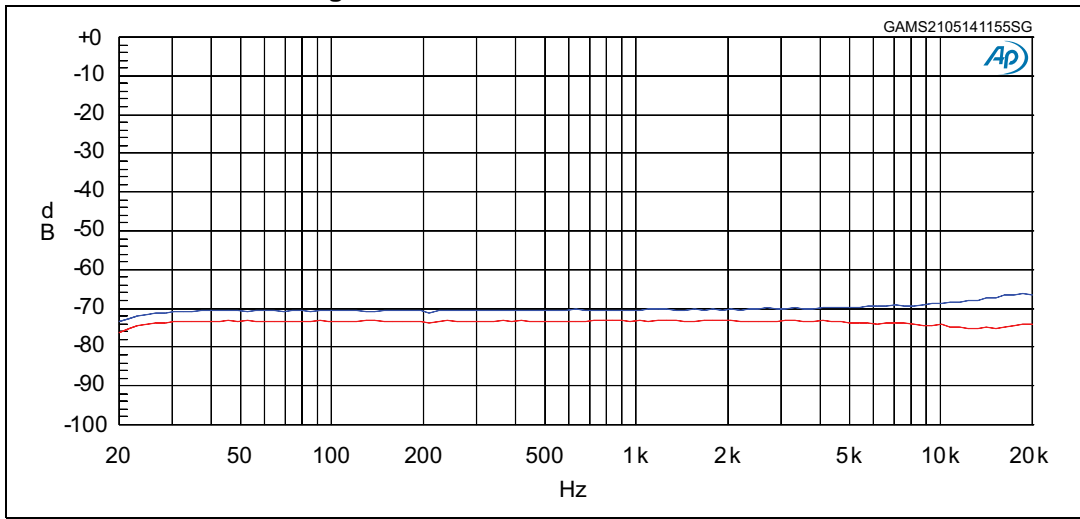
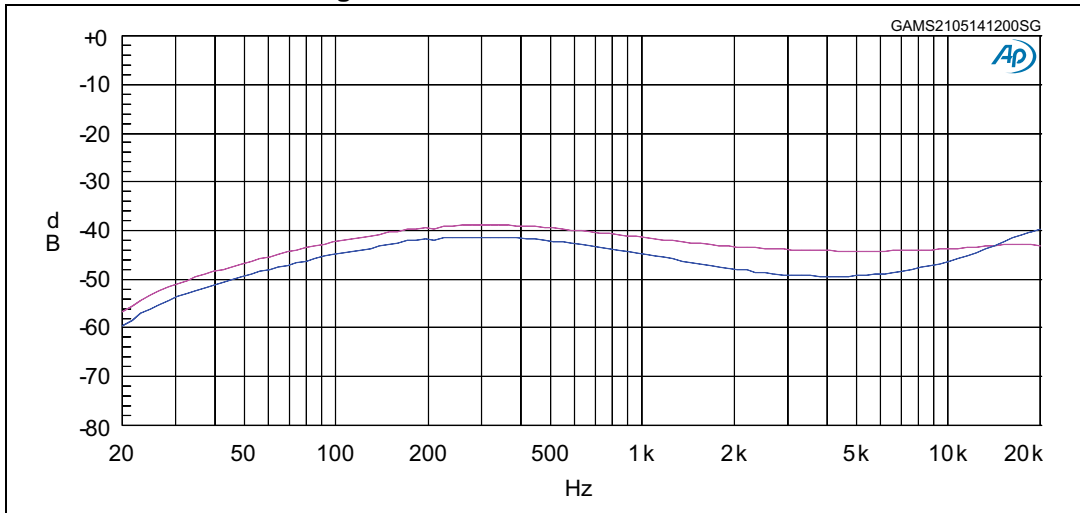

Figure 22. Crosstalk 36 V 3 Ω SE 1 W



5 Output filter

The differential-mode damping of a hybrid filter under no-load conditions is not as good as a pure common-mode filter because most of the high-frequency current flows through the larger capacitor across the speaker terminals. Normally this isn't a problem because the speaker provides the differential-mode damping, but if the amplifier is operated without the speaker connected, for instance when doing testing in production line, then the damping will not be as good.

Care needs to be taken to insure that the damping of a hybrid filter is good enough to protect the amplifier under no-load conditions, thus avoiding peak of voltage that exceed the absolute maximum voltage of the amplifier.

Figure 23. Output filter frequency response with and without load connected to the amplifier

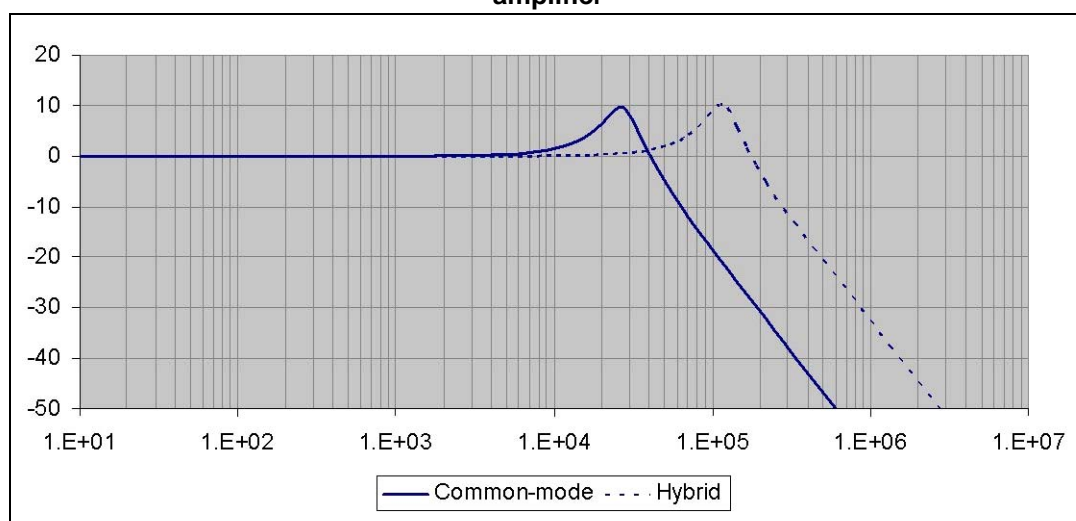

To allow the right filter selection both sets of coefficients are provided.

5.1 Theoretical filter

Perfect when using amplifiers always connected to speakers

Table 9. Theoretical table SE

Load Impedance	LC Low-Pass Filter		Damping network		
	LF	CF	CS	CP	RP
3	15 μ H	1 μ F	100 nF	100 nF	6.2 Ω
4	22 μ H	680 nF	100 nF	100 nF	6.2 Ω
6	33 μ H	470 nF	100 nF	100 nF	6.2 Ω
8	47 μ H	330 nF	100 nF	100 nF	6.2 Ω

See [Figure 8](#).

Table 10. Theoretical table BTL

Load Impedance	LC Low-Pass Filter		Damping network		
	LF	CF	CS	CP	RP
3	10 μ H	1 μ F	220 nF	220 nF	3.3 Ω
4	10 μ H	1 μ F	220 nF	220 nF	3.3 Ω
6	15 μ H	680 nF	100 nF	100 nF	4.7 Ω
8	22 μ H	470 nF	100 nF	100 nF	6.2 Ω

See [Figure 6](#).

Table 11. Theoretical table PBTL

Load Impedance	LC Low-Pass Filter		Damping network		
	LF	CF	CS	CP	RP
3	10 μ H	1 μ F	220 nF	220 nF	2.7 Ω
4	10 μ H	1 μ F	220 nF	220 nF	3.3 Ω
6	15 μ H	680 nF	100 nF	100 nF	6.2 Ω
8	22 μ H	470 nF	100 nF	100 nF	6.2 Ω

See [Figure 7](#).

5.2 Optimized filter

Suggest to avoid resonant peak when running amplifiers without load

Table 12. Filter optimized to minimize the peak SE

Load Impedance	LC Low-Pass Filter		Damping network		
	LF	CF	CS	CP	RP
3	15 μ H	680 μ F	100 nF	100 nF	6.2 Ω
4	22 μ H	470 nF	100 nF	100 nF	6.2 Ω
6	33 μ H	330 nF	100 nF	100 nF	6.2 Ω
8	47 μ H	220 nF	100 nF	100 nF	6.2 Ω

See [Figure 8](#).

Table 13. Filter optimized to minimize the peak BTL

Load Impedance	LC Low-Pass Filter		Damping network		
	LF	CF	CS	CP	RP
3	10 μ H	680 nF	220 nF	220 nF	3.3 Ω
4	10 μ H	680 nF	220 nF	220 nF	3.3 Ω
6	15 μ H	470 nF	100 nF	100 nF	4.7 Ω
8	22 μ H	330 nF	100 nF	100 nF	6.2 Ω

See [Figure 6](#).

Table 14. Filter optimized to minimize the peak PBTl

Load Impedance	LC Low-Pass Filter		Damping network		
	LF	CF	CS	CP	RP
3	10 μ H	680 nF	220 nF	220 nF	2.7 Ω
4	10 μ H	680 nF	220 nF	220 nF	3.3 Ω
6	15 μ H	470 nF	100 nF	100 nF	6.2 Ω
8	22 μ H	330 nF	100 nF	100 nF	6.2 Ω

See [Figure 7](#).

6 Package information

In order to meet environmental requirements, ST offers these devices in different grades of ECOPACK[®] packages, depending on their level of environmental compliance. ECOPACK[®] specifications, grade definitions and product status are available at: www.st.com. ECOPACK[®] is an ST trademark.

Figure 24. PSSO36 (slug up) package drawing

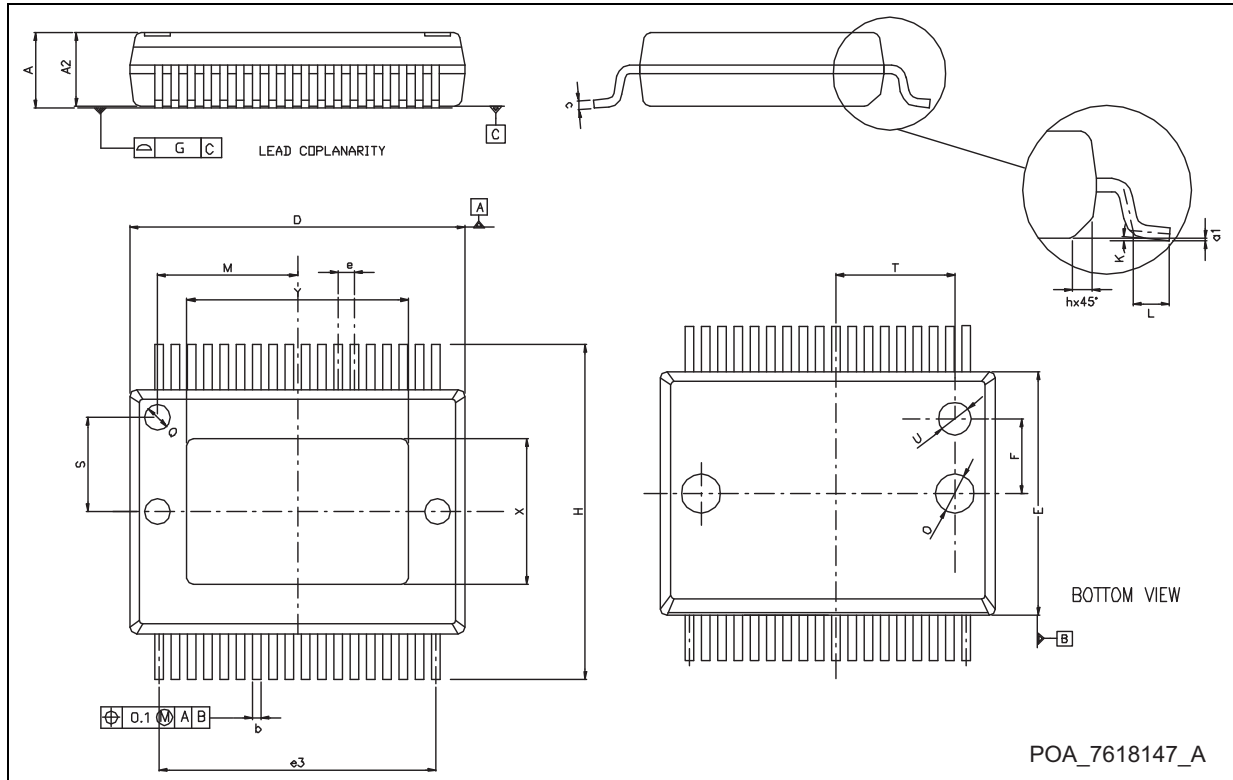

Table 15. PSSO36 (slug up) package dimensions

Dim.	mm.			inch.		
	Min.	Typ.	Max.	Min.	Typ.	Max.
A	2.15		2.47	0.084		0.097
A2	2.15		2.40	0.084		0.094
a1	0		0.075	0		0.003
b	0.18		0.36	0.007		0.014
c	0.23		0.32	0.009		0.012
D ⁽¹⁾	10.10		10.50	0.398		0.413
E ⁽¹⁾	7.4		7.6	0.291		0.299
e		0.50			0.020	
e3		8.50			0.035	
F		2.3			0.090	
G			0.10			0.004
G1			0.06			0.002
H	10.10		10.50	0.398		0.413
h			0.40			0.016
L	0.55		0.85	0.022		0.033
M		4.3			0.169	
N	10° (max.)			10° (max.)		
O		1.2			0.047	
Q		0.8			0.031	
S		2.9			0.114	
T		3.65			0.144	
U		1.0			0.039	
X	4.10		4.70	0.161		0.185
Y	6.50		7.10	0.256		0.279

1. "D and E" do not include mold flash or protrusion. Mold flash or protrusion shall not exceed 0.15 mm (0.006").

7 Trademarks and other acknowledgments

FFX is a STMicroelectronics proprietary digital modulation technology.

ECOPACK is a registered trademark of STMicroelectronics.

8 Revision history

Table 16. Document revision history

Date	Revision	Changes
13-Dec-2007	1	Initial release.
28-Jun-2011	2	Added part number STA510FTR to Table 1: Device summary Updated ECOPACK [®] text in Section 6: Package information Minor textual updates
02-Sep-2011	3	Updated package to PowerSSO36 throughout datasheet Corrected typographical error in Features Updated Figure 1 Updated Figure 2 Updated Figure 21
03-Jun-2014	4	Added: – Figure 5 on page 9 , Figure 6 on page 10 , Figure 7 on page 10 and Figure 8 on page 11 – Section 4: Characterization curves – Section 5: Output filter

Please Read Carefully:

Information in this document is provided solely in connection with ST products. STMicroelectronics NV and its subsidiaries ("ST") reserve the right to make changes, corrections, modifications or improvements, to this document, and the products and services described herein at any time, without notice.

All ST products are sold pursuant to ST's terms and conditions of sale.

Purchasers are solely responsible for the choice, selection and use of the ST products and services described herein, and ST assumes no liability whatsoever relating to the choice, selection or use of the ST products and services described herein.

No license, express or implied, by estoppel or otherwise, to any intellectual property rights is granted under this document. If any part of this document refers to any third party products or services it shall not be deemed a license grant by ST for the use of such third party products or services, or any intellectual property contained therein or considered as a warranty covering the use in any manner whatsoever of such third party products or services or any intellectual property contained therein.

UNLESS OTHERWISE SET FORTH IN ST'S TERMS AND CONDITIONS OF SALE ST DISCLAIMS ANY EXPRESS OR IMPLIED WARRANTY WITH RESPECT TO THE USE AND/OR SALE OF ST PRODUCTS INCLUDING WITHOUT LIMITATION IMPLIED WARRANTIES OF MERCHANTABILITY, FITNESS FOR A PARTICULAR PURPOSE (AND THEIR EQUIVALENTS UNDER THE LAWS OF ANY JURISDICTION), OR INFRINGEMENT OF ANY PATENT, COPYRIGHT OR OTHER INTELLECTUAL PROPERTY RIGHT.

ST PRODUCTS ARE NOT DESIGNED OR AUTHORIZED FOR USE IN: (A) SAFETY CRITICAL APPLICATIONS SUCH AS LIFE SUPPORTING, ACTIVE IMPLANTED DEVICES OR SYSTEMS WITH PRODUCT FUNCTIONAL SAFETY REQUIREMENTS; (B) AERONAUTIC APPLICATIONS; (C) AUTOMOTIVE APPLICATIONS OR ENVIRONMENTS, AND/OR (D) AEROSPACE APPLICATIONS OR ENVIRONMENTS. WHERE ST PRODUCTS ARE NOT DESIGNED FOR SUCH USE, THE PURCHASER SHALL USE PRODUCTS AT PURCHASER'S SOLE RISK, EVEN IF ST HAS BEEN INFORMED IN WRITING OF SUCH USAGE, UNLESS A PRODUCT IS EXPRESSLY DESIGNATED BY ST AS BEING INTENDED FOR "AUTOMOTIVE, AUTOMOTIVE SAFETY OR MEDICAL" INDUSTRY DOMAINS ACCORDING TO ST PRODUCT DESIGN SPECIFICATIONS. PRODUCTS FORMALLY ESCC, QML OR JAN QUALIFIED ARE DEEMED SUITABLE FOR USE IN AEROSPACE BY THE CORRESPONDING GOVERNMENTAL AGENCY.

Resale of ST products with provisions different from the statements and/or technical features set forth in this document shall immediately void any warranty granted by ST for the ST product or service described herein and shall not create or extend in any manner whatsoever, any liability of ST.

ST and the ST logo are trademarks or registered trademarks of ST in various countries.

Information in this document supersedes and replaces all information previously supplied.

The ST logo is a registered trademark of STMicroelectronics. All other names are the property of their respective owners.

© 2014 STMicroelectronics - All rights reserved

STMicroelectronics group of companies

Australia - Belgium - Brazil - Canada - China - Czech Republic - Finland - France - Germany - Hong Kong - India - Israel - Italy - Japan - Malaysia - Malta - Morocco - Philippines - Singapore - Spain - Sweden - Switzerland - United Kingdom - United States of America

www.st.com

AMEYA360

Components Supply Platform

Authorized Distribution Brand :



Website :

Welcome to visit www.ameya360.com

Contact Us :

➤ Address :

401 Building No.5, JiuGe Business Center, Lane 2301, Yishan Rd
Minhang District, Shanghai , China

➤ Sales :

Direct +86 (21) 6401-6692

Email amall@ameya360.com

QQ 800077892

Skype [ameyasales1](#) [ameyasales2](#)

➤ Customer Service :

Email service@ameya360.com

➤ Partnership :

Tel +86 (21) 64016692-8333

Email mkt@ameya360.com