



LFC Series 5mm Press Fit, Low Profile Diffused Rigid Light Pipe



LFC Series litepipe™ features diffused round 5mm surface for super wide viewing angle at 120 degrees

Applications

- audio/video
- communication
- darkroom equipment
- electrical panels
- entertainment
- industrial
- medical
- IoT
- security
- studio control
- transportation

Key features

- for use with surface-mount or through-hole LED
- optical grade polycarbonate for maximum light transmission
- low profile, flush panel design
- wide viewing angle at 120 degrees
- frosted surface diffuses light and provides uniform brightness and a soft glow
- press fit (front panel mount) with crushable ribs that simplifies installation
- no physical connection between light pipe and LED provides versatility for assembly
- standard lengths from 0.125" to 1.000"
- custom lengths available
- RTN125 retainer provides a reliable solution for high-vibration environments (optional)

Dimensions

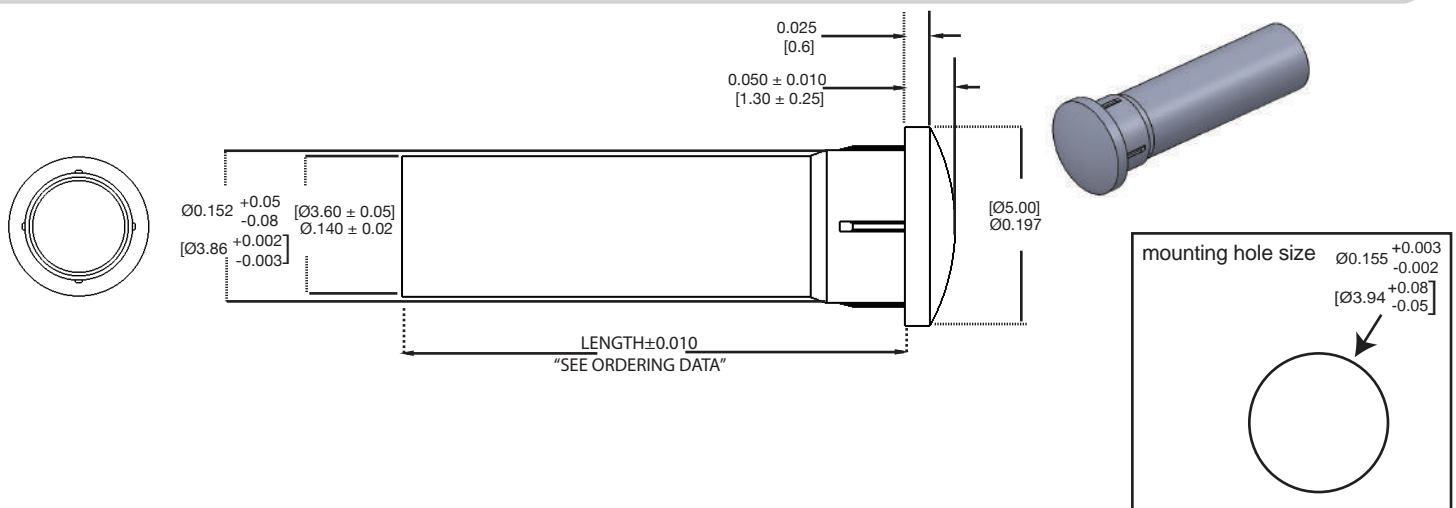

Dimensions in inches [mm]

Product Specifications

Material
Polycarbonate, clear, UL 94-V0

Installation Specification	
mounting hole	0.155" +0.003/-0.002 (3.94mm +0.08/-0.05)
panel thickness	0.040" (1.02mm) to 0.093"(2.36mm)

Recommendation: Maximum air gap (clearance) between LED and light pipe for best performance:

- 0.020" for wide viewing angle LED
- 0.050" for narrow viewing angle LED

Ordering Data

LFC CTP

	Length
012	0.125" (3.2mm)
025	0.250" (6.4mm)
035	0.350" (8.9mm)
037	0.375" (9.5mm)
050	0.500" (12.7mm)
063	0.625" (15.9mm)
075	0.750" (19.0mm)
100	1.000" (25.4mm)

Optional Accessory

Retainer for LFC Series 5mm Light Pipe (order separately)

Ordering Number: RTN125

- recommended for high vibration applications
- secure and uniform placement of the light pipe to the panel
- field-proven design

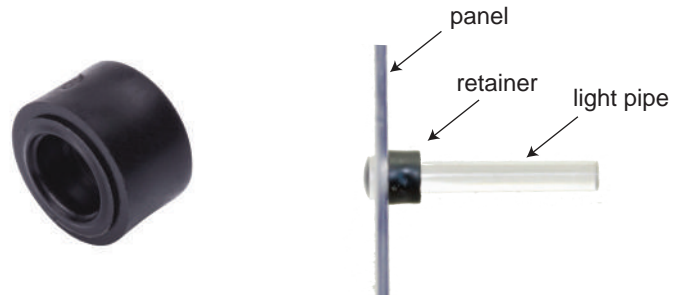

Please see datasheet RTN125 for more details

Compliance & Approvals



AMEYA360

Components Supply Platform

Authorized Distribution Brand :



Website :

Welcome to visit www.ameya360.com

Contact Us :

➤ Address :

401 Building No.5, JiuGe Business Center, Lane 2301, Yishan Rd
Minhang District, Shanghai , China

➤ Sales :

Direct +86 (21) 6401-6692

Email amall@ameya360.com

QQ 800077892

Skype [ameyasales1](#) [ameyasales2](#)

➤ Customer Service :

Email service@ameya360.com

➤ Partnership :

Tel +86 (21) 64016692-8333

Email mkt@ameya360.com