

# 74HC4060; 74HCT4060

## 14-stage binary ripple counter with oscillator

Rev. 4 — 10 February 2016

Product data sheet

### 1. General description

---

The 74HC4060; 74HCT4060 is a 14-stage ripple-carry counter/divider and oscillator with three oscillator terminals (RS, RTC and CTC), ten buffered parallel outputs (Q3 to Q9 and Q11 to Q13) and an overriding asynchronous master reset (MR). The oscillator configuration allows design of either RC or crystal oscillator circuits. The oscillator may be replaced by an external clock signal at input RS. In this case, keep the oscillator pins (RTC and CTC) floating. The counter advances on the HIGH-to-LOW transition of RS. A HIGH level on MR clears all counter stages and forces all outputs LOW, independent of the other input conditions. Inputs include clamp diodes. This enables the use of current limiting resistors to interface inputs to voltages in excess of  $V_{CC}$ .

### 2. Features and benefits

---

- All active components on chip
- RC or crystal oscillator configuration
- Complies with JEDEC standard no. 7 A
- Input levels:
  - ◆ For 74HC4060: CMOS level
  - ◆ For 74HCT4060: TTL level
- ESD protection:
  - ◆ HBM JESD22-A114F exceeds 2000 V
  - ◆ MM JESD22-A115-A exceeds 200 V
- Multiple package options
- Specified from  $-40\text{ }^{\circ}\text{C}$  to  $+85\text{ }^{\circ}\text{C}$  and from  $-40\text{ }^{\circ}\text{C}$  to  $+125\text{ }^{\circ}\text{C}$

### 3. Applications

---

- Control counters
- Timers
- Frequency dividers
- Time-delay circuits



### 4. Ordering information

Table 1. Ordering information

Type number	Package			Version
	Temperature range	Name	Description	
74HC4060D	-40 °C to +125 °C	SO16	plastic small outline package; 16 leads; body width 3.9 mm	SOT109-1
74HCT4060D				
74HC4060DB	-40 °C to +125 °C	SSOP16	plastic shrink small outline package; 16 leads; body width 5.3 mm	SOT338-1
74HCT4060DB				
74HC4060PW	-40 °C to +125 °C	TSSOP16	plastic thin shrink small outline package; 16 leads; body width 4.4 mm	SOT403-1
74HC4060BQ	-40 °C to +125 °C	DHVQFN16	plastic dual in-line compatible thermal-enhanced very thin quad flat package; no leads; 16 terminals; body 2.5 × 3.5 × 0.85 mm	SOT763-1
74HCT4060BQ				

### 5. Functional diagram

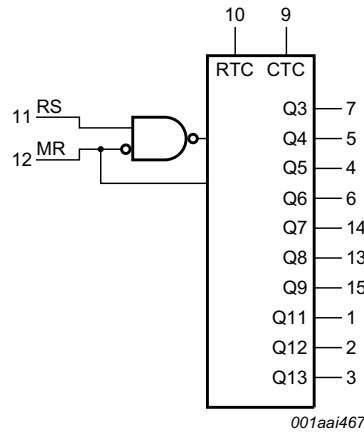

Fig 1. Logic symbol

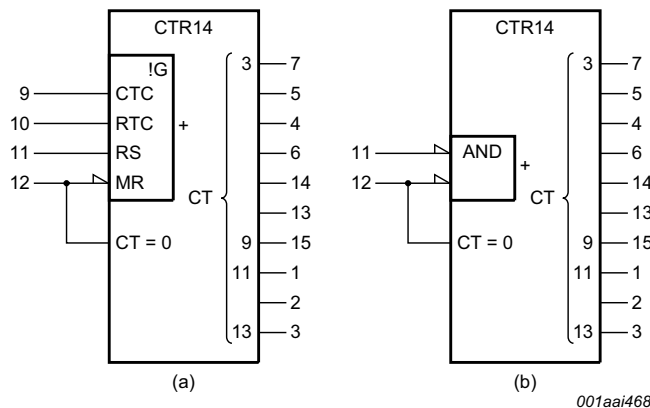

Fig 2. IEC logic symbol

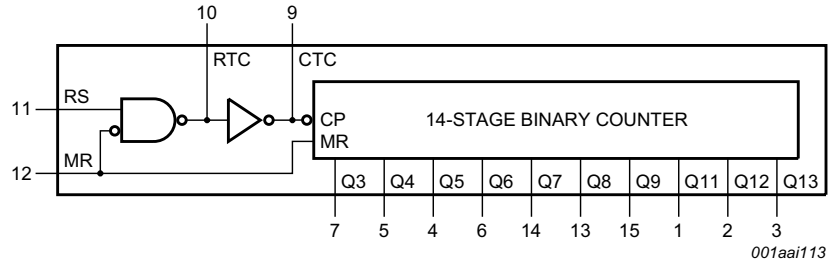

Fig 3. Functional diagram

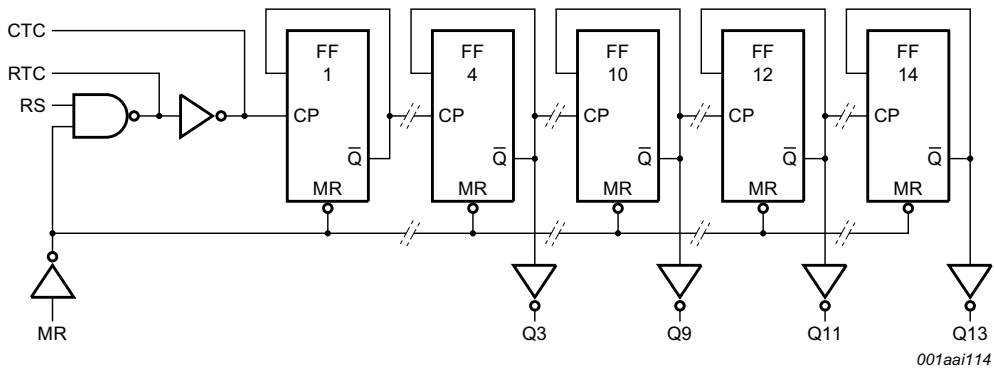
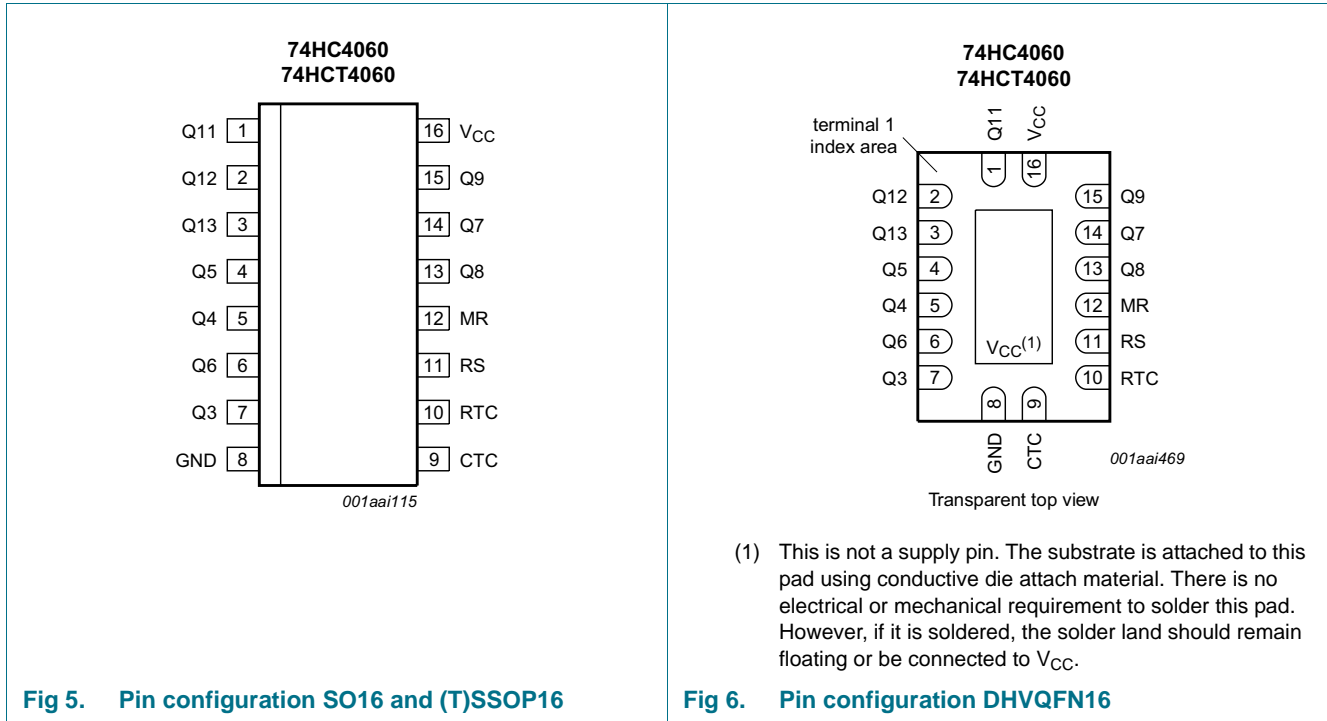

Fig 4. Logic diagram

## 6. Pinning information

### 6.1 Pinning



### 6.2 Pin description

Table 2. Pin description

Symbol	Pin	Description
Q11 to Q13	1, 2, 3	counter output
Q3 to Q9	7, 5, 4, 6, 14, 13, 15	counter output
GND	8	ground (0 V)
CTC	9	external capacitor connection
RTC	10	external resistor connection
RS	11	clock input /oscillator pin
MR	12	master reset input (active HIGH)
V <sub>CC</sub>	16	supply voltage

## 7. Functional description

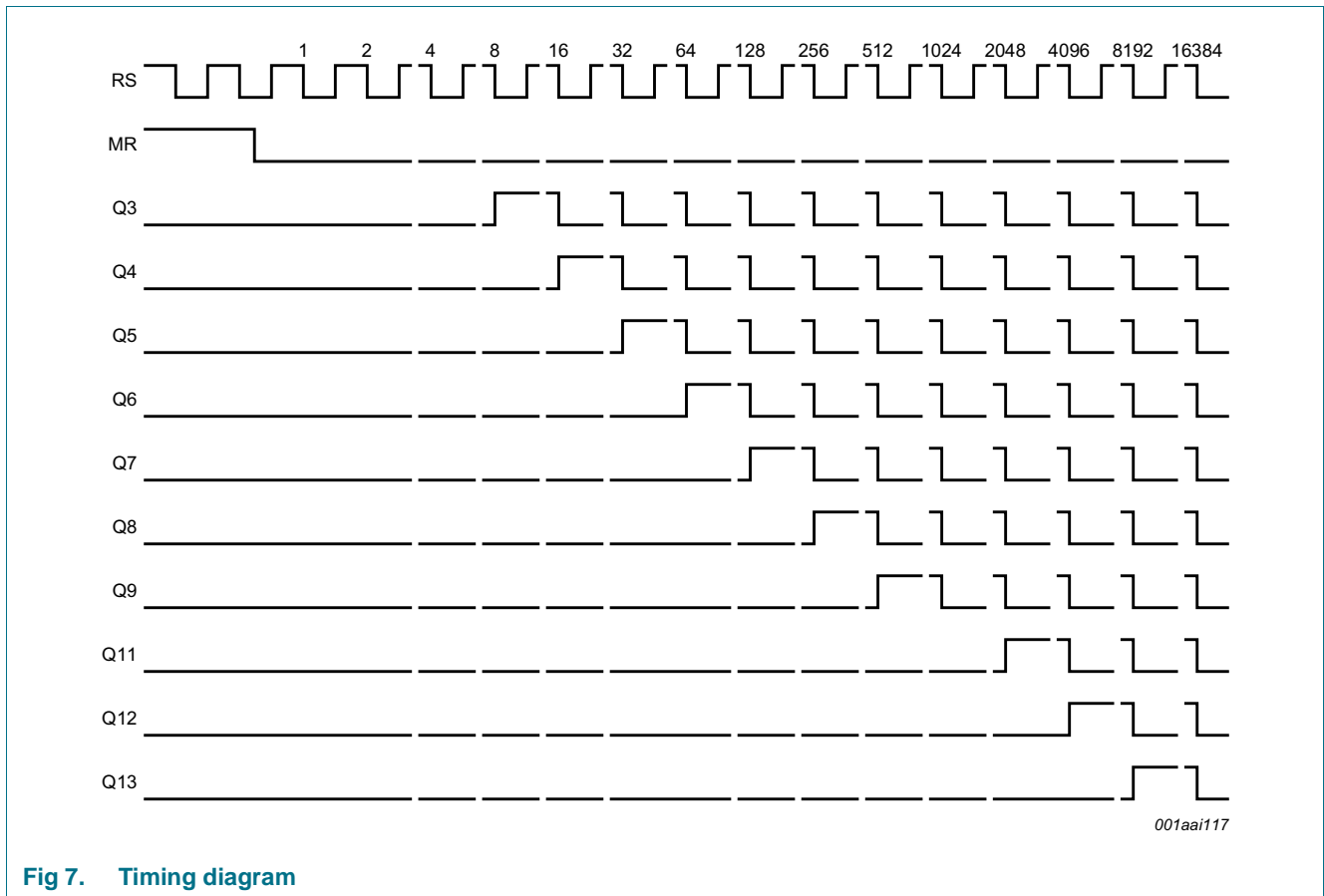

Fig 7. Timing diagram

## 8. Limiting values

Table 3. Limiting values

In accordance with the Absolute Maximum Rating System (IEC 60134). Voltages are referenced to GND (ground = 0 V).

Symbol	Parameter	Conditions	Min	Max	Unit
V <sub>CC</sub>	supply voltage		-0.5	+7	V
I <sub>IK</sub>	input clamping current	V <sub>I</sub> < -0.5 V or V <sub>I</sub> > V <sub>CC</sub> + 0.5 V [1]	-	±20	mA
I <sub>OK</sub>	output clamping current	V <sub>O</sub> < -0.5 V or V <sub>O</sub> > V <sub>CC</sub> + 0.5 V [1]	-	±20	mA
I <sub>O</sub>	output current	-0.5 V < V <sub>O</sub> < V <sub>CC</sub> + 0.5 V	-	±25	mA
I <sub>CC</sub>	supply current		-	50	mA
I <sub>GND</sub>	ground current		-50	-	mA
T <sub>stg</sub>	storage temperature		-65	+150	°C

**Table 3. Limiting values ...continued**

In accordance with the Absolute Maximum Rating System (IEC 60134). Voltages are referenced to GND (ground = 0 V).

Symbol	Parameter	Conditions	Min	Max	Unit
P <sub>tot</sub>	total power dissipation	T <sub>amb</sub> = -40 °C to +125 °C			
		SO16 package [2]	-	500	mW
		(T)SSOP16 package [3]	-	500	mW
		DHVQFN16 package [4]	-	500	mW

[1] The input and output voltage ratings may be exceeded if the input and output current ratings are observed.

[2] P<sub>tot</sub> derates linearly with 8 mW/K above 70 °C.

[3] P<sub>tot</sub> derates linearly with 5.5 mW/K above 60 °C.

[4] P<sub>tot</sub> derates linearly with 4.5 mW/K above 60 °C.

## 9. Recommended operating conditions

**Table 4. Recommended operating conditions**

Voltages are referenced to GND (ground = 0 V)

Symbol	Parameter	Conditions	74HC4060			74HCT4060			Unit
			Min	Typ	Max	Min	Typ	Max	
V <sub>CC</sub>	supply voltage		2.0	5.0	6.0	4.5	5.0	5.5	V
V <sub>I</sub>	input voltage		0	-	V <sub>CC</sub>	0	-	V <sub>CC</sub>	V
V <sub>O</sub>	output voltage		0	-	V <sub>CC</sub>	0	-	V <sub>CC</sub>	V
T <sub>amb</sub>	ambient temperature		-40	-	+125	-40	-	+125	°C
Δt/ΔV	input transition rise and fall rate	V <sub>CC</sub> = 2.0 V	-	-	625	-	-	-	ns/V
		V <sub>CC</sub> = 4.5 V	-	1.67	139	-	1.67	139	ns/V
		V <sub>CC</sub> = 6.0 V	-	-	83	-	-	-	ns/V

## 10. Static characteristics

**Table 5. Static characteristics**

At recommended operating conditions; voltages are referenced to GND (ground = 0 V).

Symbol	Parameter	Conditions	25 °C			-40 °C to +85 °C		-40 °C to +125 °C		Unit
			Min	Typ	Max	Min	Max	Min	Max	
<b>74HC4060</b>										
V <sub>IH</sub>	HIGH-level input voltage	MR input								
		V <sub>CC</sub> = 2.0 V	1.5	1.3	-	1.5	-	1.5	-	V
		V <sub>CC</sub> = 4.5 V	3.15	2.4	-	3.15	-	3.15	-	V
		V <sub>CC</sub> = 6.0 V	4.2	3.1	-	4.2	-	4.2	-	V
		RS input								
		V <sub>CC</sub> = 2.0 V	1.7	-	-	1.7	-	1.7	-	V
		V <sub>CC</sub> = 4.5 V	3.6	-	-	3.6	-	3.6	-	V
V <sub>CC</sub> = 6.0 V	4.8	-	-	4.8	-	4.8	-	V		

**Table 5. Static characteristics ...continued**

At recommended operating conditions; voltages are referenced to GND (ground = 0 V).

Symbol	Parameter	Conditions	25 °C			-40 °C to +85 °C		-40 °C to +125 °C		Unit
			Min	Typ	Max	Min	Max	Min	Max	
V <sub>IL</sub>	LOW-level input voltage	MR input								
		V <sub>CC</sub> = 2.0 V	-	0.8	0.5	-	0.5	-	0.5	V
		V <sub>CC</sub> = 4.5 V	-	2.1	1.35	-	1.35	-	1.35	V
		V <sub>CC</sub> = 6.0 V	-	2.8	1.8	-	1.8	-	1.8	V
		RS input								
		V <sub>CC</sub> = 2.0 V	-	-	0.3	-	0.3	-	0.3	V
		V <sub>CC</sub> = 4.5 V	-	-	0.9	-	0.9	-	0.9	V
		V <sub>CC</sub> = 6.0 V	-	-	1.2	-	1.2	-	1.2	V
V <sub>OH</sub>	HIGH-level output voltage	RTC output; RS = MR = GND								
		I <sub>O</sub> = -20 μA; V <sub>CC</sub> = 2.0 V	1.9	2.0	-	1.9	-	1.9	-	V
		I <sub>O</sub> = -20 μA; V <sub>CC</sub> = 4.5 V	4.4	4.5	-	4.4	-	4.4	-	V
		I <sub>O</sub> = -20 μA; V <sub>CC</sub> = 6.0 V	5.9	6.0	-	5.9	-	5.9	-	V
		I <sub>O</sub> = -2.6 mA; V <sub>CC</sub> = 4.5 V	3.98	-	-	3.84	-	3.7	-	V
		I <sub>O</sub> = -3.3 mA; V <sub>CC</sub> = 6.0 V	5.48	-	-	5.34	-	5.2	-	V
		RTC output; RS = MR = V <sub>CC</sub>								
		I <sub>O</sub> = -20 μA; V <sub>CC</sub> = 2.0 V	1.9	2.0	-	1.9	-	1.9	-	V
		I <sub>O</sub> = -20 μA; V <sub>CC</sub> = 4.5 V	4.4	4.5	-	4.4	-	4.4	-	V
		I <sub>O</sub> = -20 μA; V <sub>CC</sub> = 6.0 V	5.9	6.0	-	5.9	-	5.9	-	V
		I <sub>O</sub> = -0.65 mA; V <sub>CC</sub> = 4.5 V	3.98	-	-	3.84	-	3.7	-	V
		I <sub>O</sub> = -0.85 mA; V <sub>CC</sub> = 6.0 V	5.48	-	-	5.34	-	5.2	-	V
		CTC output; RS = V <sub>IH</sub> ; MR = V <sub>IL</sub>								
		I <sub>O</sub> = -3.2 mA; V <sub>CC</sub> = 4.5 V	3.98	-	-	3.84	-	3.7	-	V
		I <sub>O</sub> = -4.2 mA; V <sub>CC</sub> = 6.0 V	5.48	-	-	5.34	-	5.2	-	V
		V <sub>I</sub> = V <sub>IH</sub> or V <sub>IL</sub> ; except RTC output								
		I <sub>O</sub> = -20 μA; V <sub>CC</sub> = 2.0 V	1.9	2.0	-	1.9	-	1.9	-	V
		I <sub>O</sub> = -20 μA; V <sub>CC</sub> = 4.5 V	4.4	4.5	-	4.4	-	4.4	-	V
		I <sub>O</sub> = -20 μA; V <sub>CC</sub> = 6.0 V	5.9	6.0	-	5.9	-	5.9	-	V
		V <sub>I</sub> = V <sub>IH</sub> or V <sub>IL</sub> ; except RTC and CTC outputs								
I <sub>O</sub> = -4.0 mA; V <sub>CC</sub> = 4.5 V	3.98	-	-	3.84	-	3.7	-	V		
I <sub>O</sub> = -5.2 mA; V <sub>CC</sub> = 6.0 V	5.48	-	-	5.34	-	5.2	-	V		

**Table 5. Static characteristics ...continued**

At recommended operating conditions; voltages are referenced to GND (ground = 0 V).

Symbol	Parameter	Conditions	25 °C			-40 °C to +85 °C		-40 °C to +125 °C		Unit
			Min	Typ	Max	Min	Max	Min	Max	
V <sub>OL</sub>	LOW-level output voltage	RTC output; RS = V <sub>CC</sub> ; MR = GND								
		I <sub>O</sub> = 20 μA; V <sub>CC</sub> = 2.0 V	-	0	0.1	-	0.1	-	0.1	V
		I <sub>O</sub> = 20 μA; V <sub>CC</sub> = 4.5 V	-	0	0.1	-	0.1	-	0.1	V
		I <sub>O</sub> = 20 μA; V <sub>CC</sub> = 6.0 V	-	0	0.1	-	0.1	-	0.1	V
		I <sub>O</sub> = 2.6 mA; V <sub>CC</sub> = 4.5 V	-	-	0.26	-	0.33	-	0.4	V
		I <sub>O</sub> = 3.3 mA; V <sub>CC</sub> = 6.0 V	-	-	0.26	-	0.33	-	0.4	V
		CTC output; RS = V <sub>IL</sub> ; MR = V <sub>IH</sub>								
		I <sub>O</sub> = 3.2 mA; V <sub>CC</sub> = 4.5 V	-	-	0.26	-	0.33	-	0.4	V
		I <sub>O</sub> = 4.2 mA; V <sub>CC</sub> = 6.0 V	-	-	0.26	-	0.33	-	0.4	V
		V <sub>I</sub> = V <sub>IH</sub> or V <sub>IL</sub> ; except RTC output								
		I <sub>O</sub> = 20 μA; V <sub>CC</sub> = 2.0 V	-	0	0.1	-	0.1	-	0.1	V
		I <sub>O</sub> = 20 μA; V <sub>CC</sub> = 4.5 V	-	0	0.1	-	0.1	-	0.1	V
		I <sub>O</sub> = 20 μA; V <sub>CC</sub> = 6.0 V	-	0	0.1	-	0.1	-	0.1	V
		V <sub>I</sub> = V <sub>IH</sub> or V <sub>IL</sub> ; except RTC and CTC outputs								
I <sub>O</sub> = 4.0 mA; V <sub>CC</sub> = 4.5 V	-	-	0.26	-	0.33	-	0.4	V		
I <sub>O</sub> = 5.2 mA; V <sub>CC</sub> = 6.0 V	-	-	0.26	-	0.33	-	0.4	V		
I <sub>I</sub>	input leakage current	V <sub>I</sub> = V <sub>CC</sub> or GND; V <sub>CC</sub> = 6.0 V	-	-	±0.1	-	±1.0	-	±1.0	μA
I <sub>CC</sub>	supply current	V <sub>I</sub> = V <sub>CC</sub> or GND; I <sub>O</sub> = 0 A; V <sub>CC</sub> = 6.0 V	-	-	8.0	-	80	-	160	μA
C <sub>I</sub>	input capacitance		-	3.5	-	-	-	-	-	pF
<b>74HCT4060</b>										
V <sub>IH</sub>	HIGH-level input voltage	MR input; V <sub>CC</sub> = 4.5 V to 5.5 V <sup>[1]</sup>	2.0	-	-	2.0	-	2.0	-	V
		RS input; V <sub>CC</sub> = 4.5 V	3.6	-	-	3.6	-	3.6	-	V
V <sub>IL</sub>	LOW-level input voltage	MR input; V <sub>CC</sub> = 4.5 V to 5.5 V <sup>[1]</sup>	-	-	0.8	-	0.8	-	0.8	V
		RS input; V <sub>CC</sub> = 4.5 V	-	-	0.9	-	0.9	-	0.9	V



**Table 5. Static characteristics ...continued**

At recommended operating conditions; voltages are referenced to GND (ground = 0 V).

Symbol	Parameter	Conditions	25 °C			-40 °C to +85 °C		-40 °C to +125 °C		Unit
			Min	Typ	Max	Min	Max	Min	Max	
V <sub>OH</sub>	HIGH-level output voltage	RTC output; RS = MR = V <sub>CC</sub>								
		I <sub>O</sub> = -20 μA; V <sub>CC</sub> = 4.5 V	4.4	4.5	-	4.4	-	4.4	-	V
		I <sub>O</sub> = -0.65 mA; V <sub>CC</sub> = 4.5 V	3.98	-	-	3.84	-	3.7	-	V
		RTC output; RS = MR = GND								
		I <sub>O</sub> = -20 μA; V <sub>CC</sub> = 4.5 V	4.4	4.5	-	4.4	-	4.4	-	V
		I <sub>O</sub> = -2.6 mA; V <sub>CC</sub> = 4.5 V	3.98	-	-	3.84	-	3.7	-	V
		CTC output; RS = V <sub>IH</sub> ; MR = V <sub>IL</sub>								
		I <sub>O</sub> = -3.2 mA; V <sub>CC</sub> = 4.5 V	3.98	-	-	3.84	-	3.7	-	V
		V <sub>I</sub> = V <sub>IH</sub> or V <sub>IL</sub> ; except RTC output								
		I <sub>O</sub> = -20 μA; V <sub>CC</sub> = 4.5 V	4.4	4.5	-	4.4	-	4.4	-	V
V <sub>OL</sub>	LOW-level output voltage	RTC output; RS = V <sub>CC</sub> ; MR = GND								
		I <sub>O</sub> = 20 μA; V <sub>CC</sub> = 4.5 V	-	0	0.1	-	0.1	-	0.1	V
		I <sub>O</sub> = 2.6 mA; V <sub>CC</sub> = 4.5 V	-	-	0.26	-	0.33	-	0.4	V
		CTC output; RS = V <sub>IL</sub> ; MR = V <sub>IH</sub>								
		I <sub>O</sub> = 3.2 mA; V <sub>CC</sub> = 4.5 V	-	-	0.26	-	0.33	-	0.4	V
		V <sub>I</sub> = V <sub>IH</sub> or V <sub>IL</sub> ; except RTC output								
		I <sub>O</sub> = 20 μA; V <sub>CC</sub> = 4.5 V	-	0	0.1	-	0.1	-	0.1	V
		V <sub>I</sub> = V <sub>IH</sub> or V <sub>IL</sub> ; except RTC and CTC outputs								
I <sub>O</sub> = 4.0 mA; V <sub>CC</sub> = 4.5 V	-	-	0.26	-	0.33	-	0.4	V		
I <sub>I</sub>	input leakage current	V <sub>I</sub> = V <sub>CC</sub> or GND; V <sub>CC</sub> = 5.5 V	-	-	±0.1	-	±1.0	-	±1.0	μA
I <sub>CC</sub>	supply current	V <sub>I</sub> = V <sub>CC</sub> or GND; V <sub>CC</sub> = 5.5 V; I <sub>O</sub> = 0 A	-	-	8.0	-	80	-	160	μA
ΔI <sub>CC</sub>	additional supply current	per input pin; V <sub>I</sub> = V <sub>CC</sub> - 2.1 V; other inputs at V <sub>CC</sub> or GND; V <sub>CC</sub> = 4.5 V to 5.5 V; I <sub>O</sub> = 0 A	-	40	144	-	180	-	196	μA
C <sub>I</sub>	input capacitance		-	3.5	-	-	-	-	-	pF

[1] For HCT4060, only input MR (pin 12) has TTL input switching levels.

## 11. Dynamic characteristics

**Table 6. Dynamic characteristics**

$GND = 0\text{ V}$ ;  $C_L = 50\text{ pF}$  unless otherwise specified; for test circuit see [Figure 11](#).

Symbol	Parameter	Conditions	25 °C			-40 °C to +85 °C		-40 °C to +125 °C		Unit
			Min	Typ	Max	Min	Max	Min	Max	
<b>74HC4060</b>										
$t_{pd}$	propagation delay	RS to Q3; see <a href="#">Figure 8</a> <sup>[1]</sup>								
		$V_{CC} = 2.0\text{ V}$	-	99	300	-	375	-	450	ns
		$V_{CC} = 4.5\text{ V}$	-	36	60	-	75	-	90	ns
		$V_{CC} = 5.0\text{ V}$ ; $C_L = 15\text{ pF}$	-	31	-	-	-	-	-	ns
		$V_{CC} = 6.0\text{ V}$	-	29	51	-	64	-	77	ns
		Qn to Qn+1; see <a href="#">Figure 9</a> <sup>[2]</sup>								
		$V_{CC} = 2.0\text{ V}$	-	22	80	-	100	-	120	ns
		$V_{CC} = 4.5\text{ V}$	-	8	16	-	20	-	24	ns
$t_{PHL}$	HIGH to LOW propagation delay	MR to Qn; see <a href="#">Figure 10</a>								
		$V_{CC} = 2.0\text{ V}$	-	55	175	-	220	-	265	ns
		$V_{CC} = 4.5\text{ V}$	-	20	35	-	44	-	53	ns
		$V_{CC} = 5.0\text{ V}$ ; $C_L = 15\text{ pF}$	-	17	-	-	-	-	-	ns
$t_t$	transition time	Qn; see <a href="#">Figure 8</a> <sup>[3]</sup>								
		$V_{CC} = 2.0\text{ V}$	-	19	75	-	95	-	110	ns
		$V_{CC} = 4.5\text{ V}$	-	7	15	-	19	-	22	ns
		$V_{CC} = 6.0\text{ V}$	-	6	13	-	16	-	19	ns
$t_w$	pulse width	RS (HIGH or LOW); see <a href="#">Figure 8</a>								
		$V_{CC} = 2.0\text{ V}$	80	17	-	100	-	120	-	ns
		$V_{CC} = 4.5\text{ V}$	16	6	-	20	-	24	-	ns
		$V_{CC} = 6.0\text{ V}$	14	5	-	17	-	20	-	ns
		MR (HIGH); see <a href="#">Figure 10</a>								
		$V_{CC} = 2.0\text{ V}$	80	25	-	100	-	120	-	ns
		$V_{CC} = 4.5\text{ V}$	16	9	-	20	-	24	-	ns
$t_{rec}$	recovery time	MR to RS; see <a href="#">Figure 10</a>								
		$V_{CC} = 2.0\text{ V}$	100	28	-	125	-	150	-	ns
		$V_{CC} = 4.5\text{ V}$	20	10	-	25	-	30	-	ns
		$V_{CC} = 6.0\text{ V}$	17	8	-	21	-	26	-	ns

**Table 6. Dynamic characteristics ...continued**  
*GND = 0 V; C<sub>L</sub> = 50 pF unless otherwise specified; for test circuit see Figure 11.*

Symbol	Parameter	Conditions	25 °C			-40 °C to +85 °C		-40 °C to +125 °C		Unit
			Min	Typ	Max	Min	Max	Min	Max	
f <sub>max</sub>	maximum frequency	RS; see <a href="#">Figure 8</a>								
		V <sub>CC</sub> = 2.0 V	6	26	-	4.8	-	4	-	MHz
		V <sub>CC</sub> = 4.5 V	30	80	-	24	-	20	-	MHz
		V <sub>CC</sub> = 5.0 V; C <sub>L</sub> = 15 pF	-	87	-	-	-	-	-	MHz
		V <sub>CC</sub> = 6.0 V	35	95	-	28	-	24	-	MHz
C <sub>PD</sub>	power dissipation capacitance	V <sub>I</sub> = GND to V <sub>CC</sub> ; V <sub>CC</sub> = 5 V; f <sub>i</sub> = 1 MHz <a href="#">[4]</a>	-	40	-	-	-	-	-	pF
<b>74HCT4060</b>										
t <sub>pd</sub>	propagation delay	RS to Q3; see <a href="#">Figure 8</a> <a href="#">[1]</a>								
		V <sub>CC</sub> = 4.5 V	-	33	66	-	83	-	99	ns
		V <sub>CC</sub> = 5.0 V; C <sub>L</sub> = 15 pF	-	31	-	-	-	-	-	ns
		Qn to Qn+1; see <a href="#">Figure 9</a> <a href="#">[2]</a>								
		V <sub>CC</sub> = 4.5 V	-	8	16	-	20	-	24	ns
		V <sub>CC</sub> = 5.0 V; C <sub>L</sub> = 15 pF	-	6	-	-	-	-	-	ns
t <sub>PHL</sub>	HIGH to LOW propagation delay	MR to Qn; see <a href="#">Figure 10</a>								
		V <sub>CC</sub> = 4.5 V	-	21	44	-	55	-	66	ns
		V <sub>CC</sub> = 5.0 V; C <sub>L</sub> = 15 pF	-	18	-	-	-	-	-	ns
t <sub>t</sub>	transition time	Qn; see <a href="#">Figure 8</a> <a href="#">[3]</a>								
		V <sub>CC</sub> = 4.5 V	-	7	15	-	19	-	22	ns
t <sub>w</sub>	pulse width	RS (HIGH or LOW); see <a href="#">Figure 8</a>								
		V <sub>CC</sub> = 4.5 V	16	6	-	20	-	24	-	ns
		MR (HIGH); see <a href="#">Figure 10</a>								
		V <sub>CC</sub> = 4.5 V	16	6	-	20	-	24	-	ns
t <sub>rec</sub>	recovery time	MR to RS; see <a href="#">Figure 10</a>								
		V <sub>CC</sub> = 4.5 V	26	13	-	33	-	39	-	ns
f <sub>max</sub>	maximum frequency	RS; see <a href="#">Figure 8</a>								
		V <sub>CC</sub> = 4.5 V	30	80	-	24	-	20	-	MHz
		V <sub>CC</sub> = 5.0 V; C <sub>L</sub> = 15 pF	-	88	-	-	-	-	-	MHz

**Table 6. Dynamic characteristics ...continued**  
*GND = 0 V; C<sub>L</sub> = 50 pF unless otherwise specified; for test circuit see Figure 11.*

Symbol	Parameter	Conditions	25 °C			-40 °C to +85 °C		-40 °C to +125 °C		Unit
			Min	Typ	Max	Min	Max	Min	Max	
C <sub>PD</sub>	power dissipation capacitance	V <sub>I</sub> = GND to V <sub>CC</sub> - 1.5 V; [4] V <sub>CC</sub> = 5 V; f <sub>i</sub> = 1 MHz	-	40	-	-	-	-	-	pF

- [1] t<sub>pd</sub> is the same as t<sub>PHL</sub> and t<sub>PLH</sub>.
- [2] Q<sub>n+1</sub> is the next Q<sub>n</sub> output.
- [3] t<sub>i</sub> is the same as t<sub>THL</sub> and t<sub>TLH</sub>.
- [4] C<sub>PD</sub> is used to determine the dynamic power dissipation (P<sub>D</sub> in μW):  
 $P_D = C_{PD} \times V_{CC}^2 \times f_i \times N + \sum(C_L \times V_{CC}^2 \times f_o)$  where:  
 f<sub>i</sub> = input frequency in MHz;  
 f<sub>o</sub> = output frequency in MHz;  
 C<sub>L</sub> = output load capacitance in pF;  
 V<sub>CC</sub> = supply voltage in V;  
 N = number of inputs switching;  
 Σ(C<sub>L</sub> × V<sub>CC</sub><sup>2</sup> × f<sub>o</sub>) = sum of outputs.

## 12. Waveforms

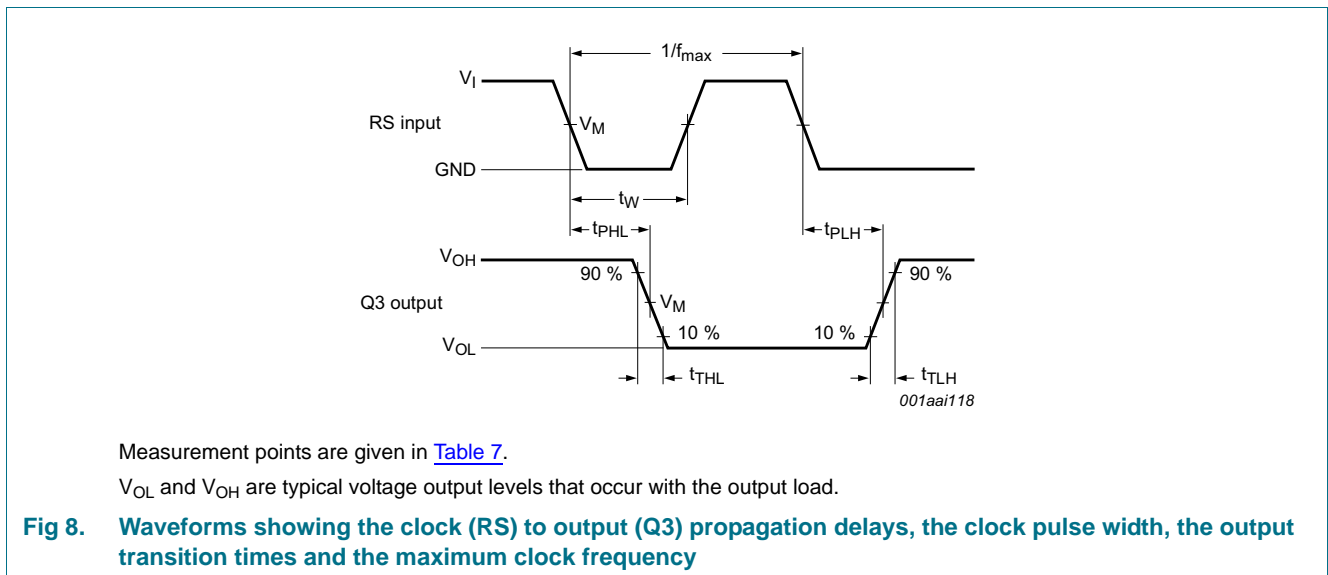

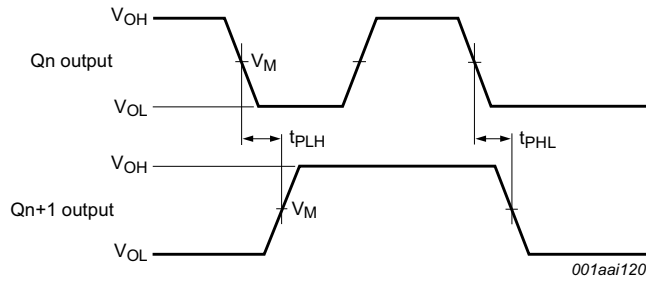

Measurement points are given in [Table 7](#).  
 $V_{OL}$  and  $V_{OH}$  are typical voltage output levels that occur with the output load.

**Fig 9. Waveforms showing the output Qn to output Qn+1 propagation delays**

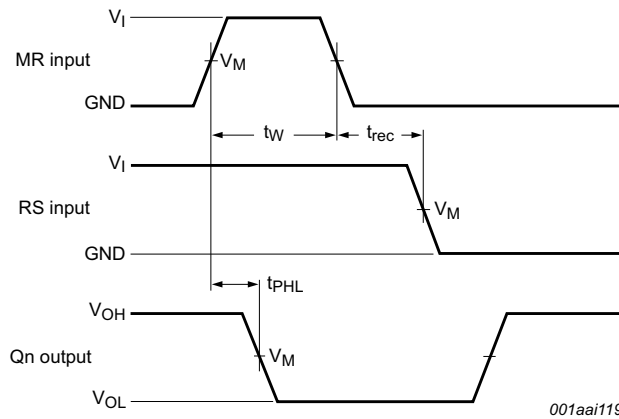

Measurement points are given in [Table 7](#).  
 $V_{OL}$  and  $V_{OH}$  are typical voltage output levels that occur with the output load.

**Fig 10. Waveforms showing the master reset (MR) pulse width, the master reset to output (Qn) propagation delays and the master reset to clock (RS) recovery time**

**Table 7. Measurement points**

Type	Input	Output
	$V_M$	$V_M$
74HC4060	$0.5 \times V_{CC}$	$0.5 \times V_{CC}$
74HCT4060	1.3 V	1.3 V

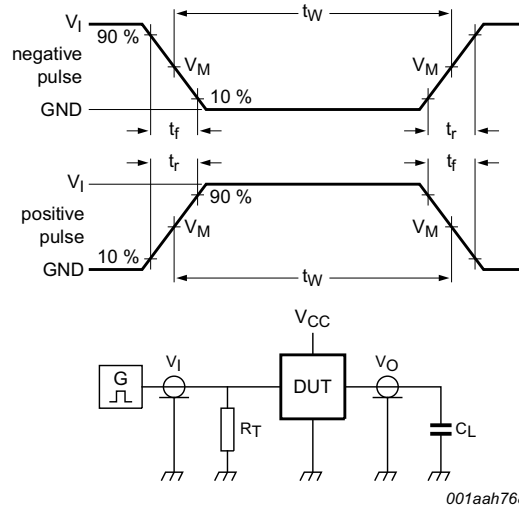

Test data is given in [Table 8](#).

Definitions test circuit:

$R_T$  = Termination resistance should be equal to output impedance  $Z_o$  of the pulse generator.

$C_L$  = Load capacitance including jig and probe capacitance.

**Fig 11. Test circuit for measuring switching times**

**Table 8. Test data**

Type	Input		Load
	$V_I$	$t_r, t_f$	$C_L$
74HC4060	$V_{CC}$	6 ns	15 pF, 50 pF
74HCT4060	3 V	6 ns	15 pF, 50 pF

### 13. RC oscillator

#### 13.1 Timing component limitations

The oscillator frequency is mainly determined by  $R_t C_t$ , provided  $R_2 \approx 2R_t$  and  $R_2 C_2 \ll R_t C_t$ . The function of  $R_2$  is to minimize the influence of the forward voltage across the input protection diodes on the frequency. The stray capacitance  $C_2$  should be kept as small as possible. In consideration of accuracy,  $C_t$  must be larger than the inherent stray capacitance.  $R_t$  must be larger than the ON resistance in series with it, which typically is 280  $\Omega$  at  $V_{CC} = 2.0$  V, 130  $\Omega$  at  $V_{CC} = 4.5$  V and 100  $\Omega$  at  $V_{CC} = 6.0$  V.

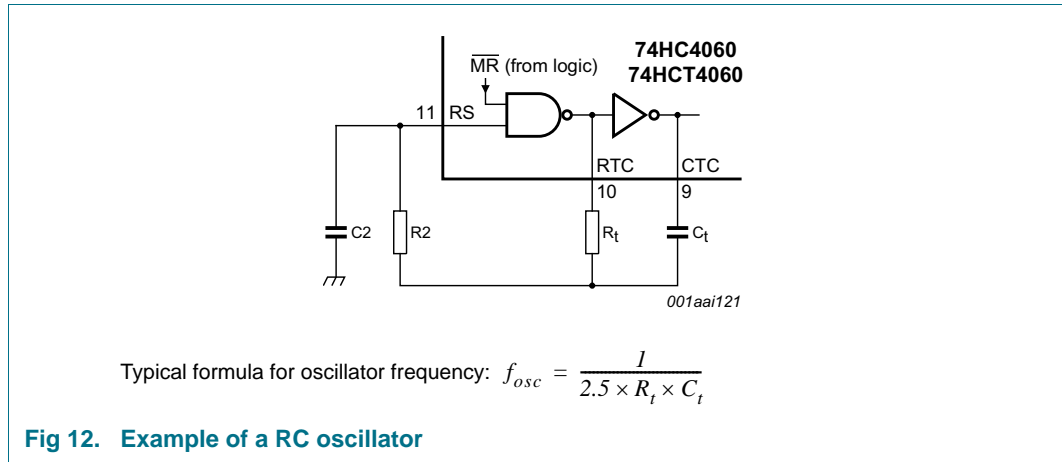

Fig 12. Example of a RC oscillator

The recommended values for these components to maintain agreement with the typical oscillation formula are:

$C_t > 50$  pF, up to any practical value and  $10 \text{ k}\Omega < R_t < 1 \text{ M}\Omega$ .

In order to avoid start-up problems,  $R_t \geq 1 \text{ k}\Omega$ .

#### 13.2 Typical crystal oscillator circuit

In [Figure 13](#),  $R_2$  is the power limiting resistor. For starting and maintaining oscillation a minimum transconductance is necessary, so  $R_2$  should not be too large. A practical value for  $R_2$  is 2.2 k $\Omega$ .

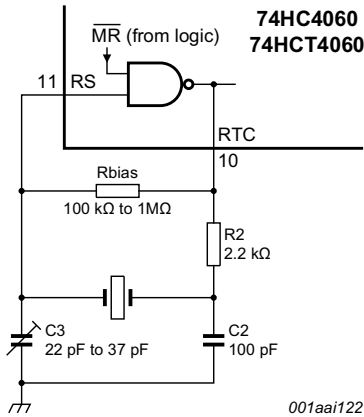

**Fig 13. External component connection for a crystal oscillator**

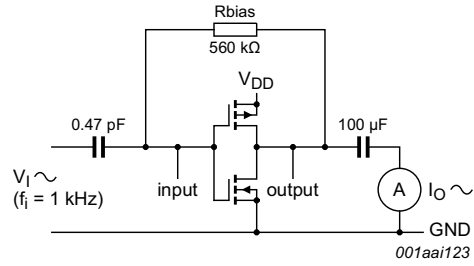

$g_{fs} = \Delta I_O / \Delta V_I$  at  $V_O$  is constant; MR = LOW.

See also [Figure 15](#).

**Fig 14. Test set-up for measuring forward transconductance**

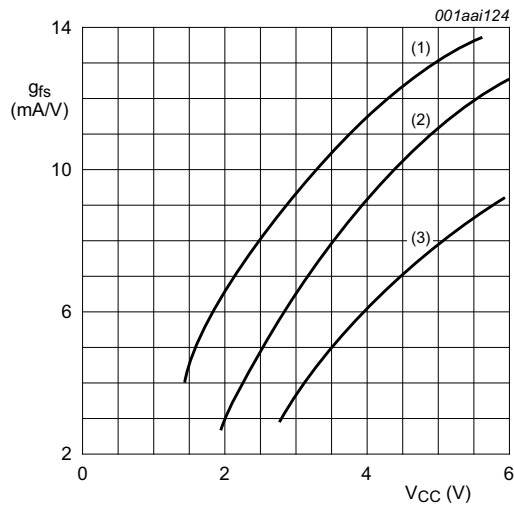

$T_{amb} = 25\text{ }^{\circ}\text{C}$ .

- (1) Maximum.
- (2) Typical.
- (3) Minimum.

**Fig 15. Typical forward transconductance as function of the supply voltage**



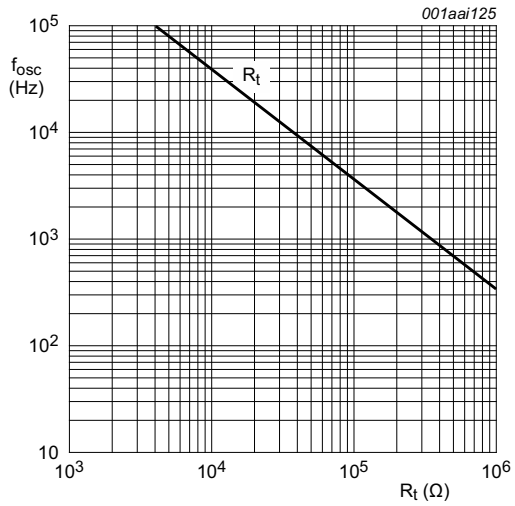

$V_{CC} = 2.0\text{ V to }6.0\text{ V}; T_{amb} = 25\text{ }^\circ\text{C}.$   
 For  $R_t$  curve:  $C_t = 1\text{ nF}; R_2 = 2 \times R_t.$

**Fig 16. RC oscillator frequency as a function of  $R_t$**

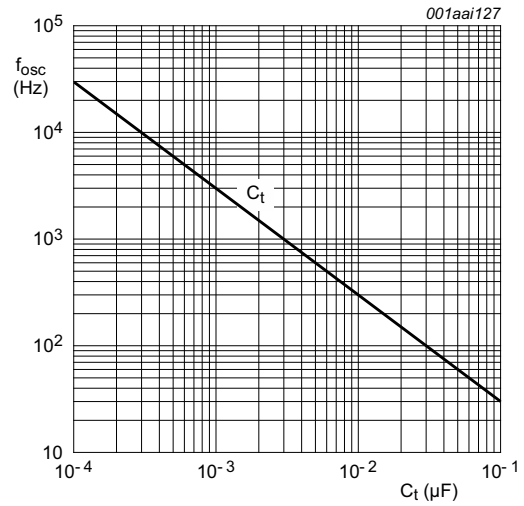

$V_{CC} = 2.0\text{ V to }6.0\text{ V}; T_{amb} = 25\text{ }^\circ\text{C}.$   
 For  $C_t$  curve:  $R_t = 100\text{ k}\Omega; R_2 = 200\text{ k}\Omega.$

**Fig 17. RC oscillator frequency as a function of  $C_t$**

14. Package outline

SO16: plastic small outline package; 16 leads; body width 3.9 mm

SOT109-1

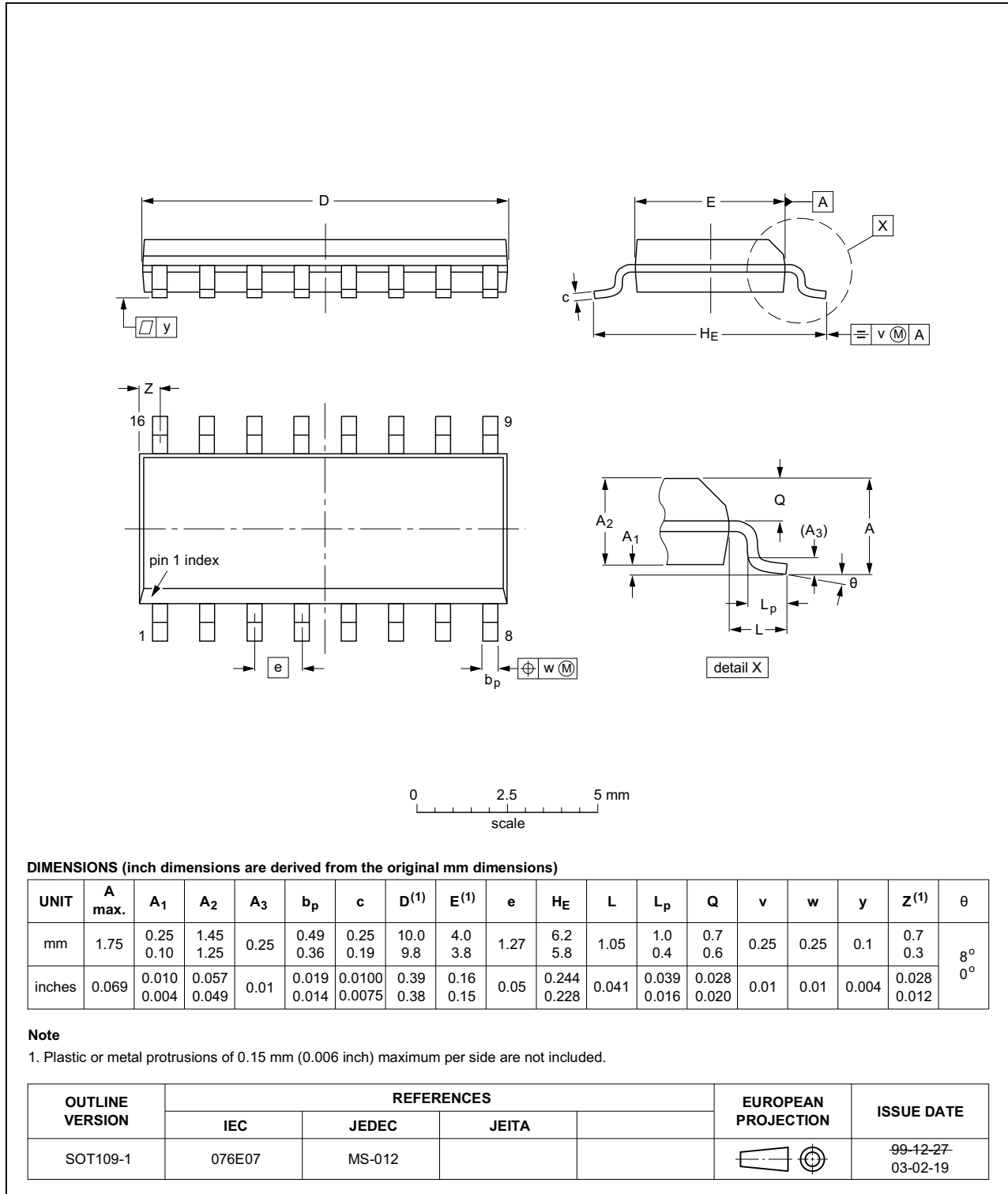

Fig 18. Package outline SOT109-1 (SO16)

SSOP16: plastic shrink small outline package; 16 leads; body width 5.3 mm

SOT338-1

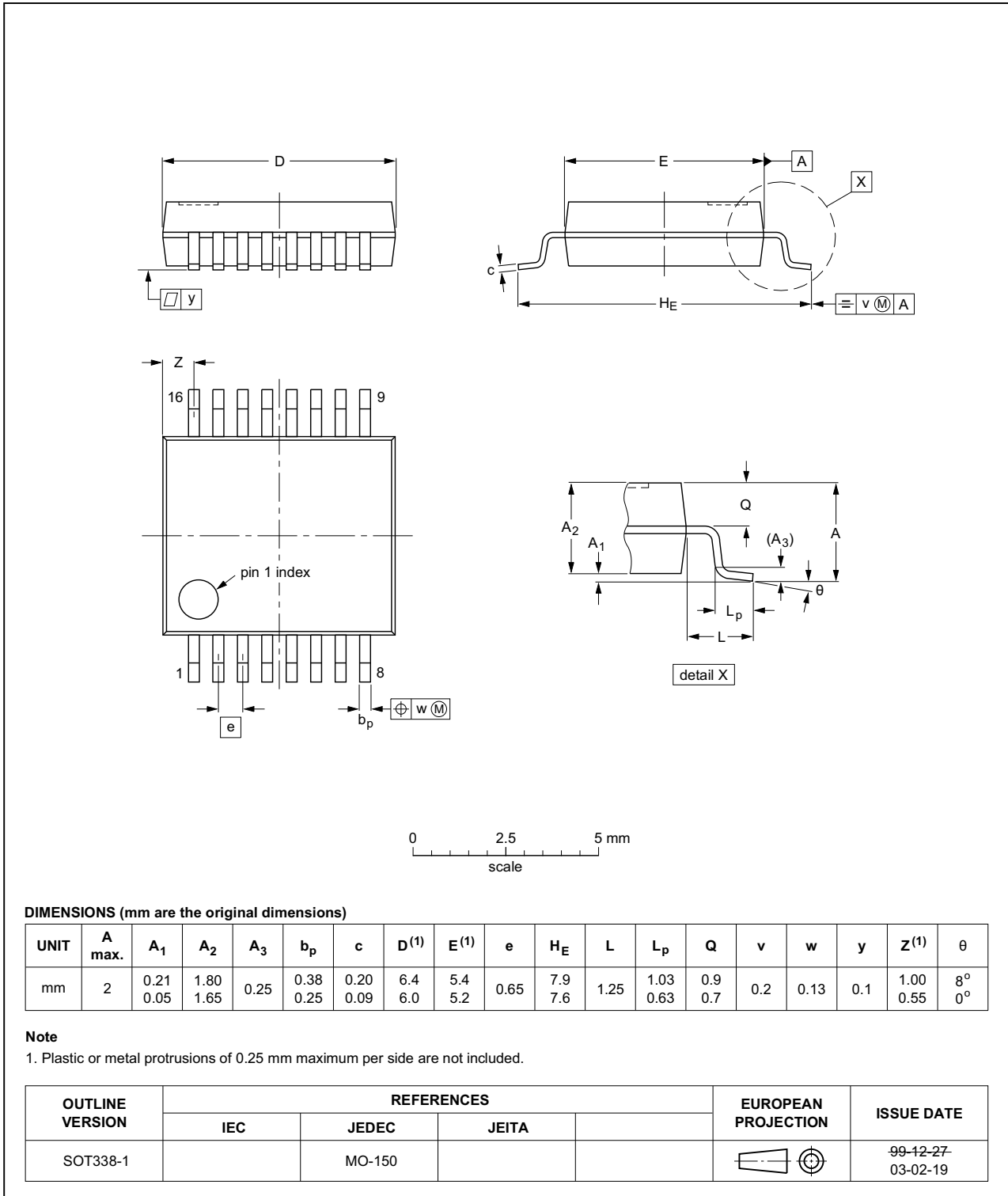

Fig 19. Package outline SOT338-1 (SSOP16)

TSSOP16: plastic thin shrink small outline package; 16 leads; body width 4.4 mm

SOT403-1

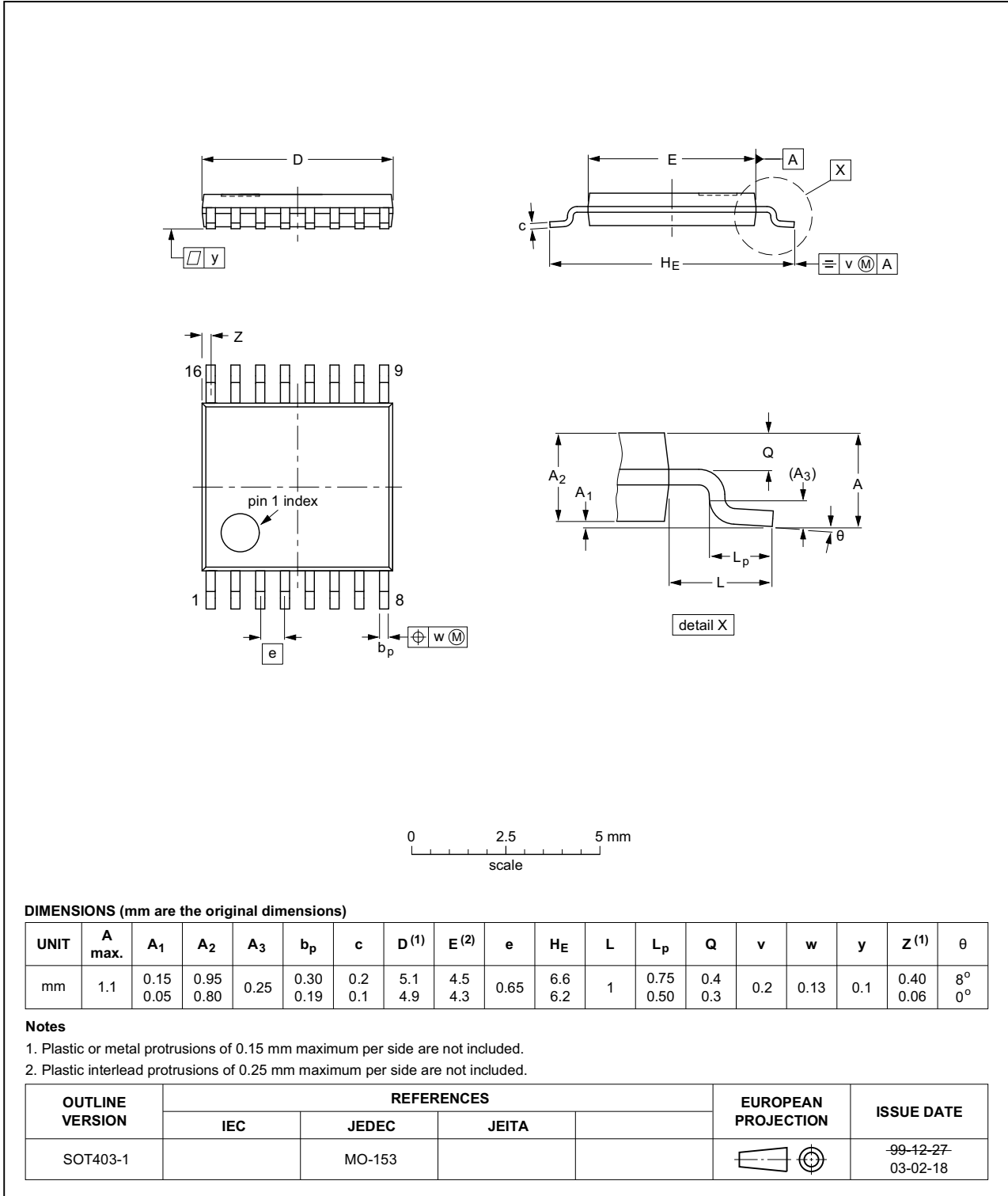

Fig 20. Package outline SOT403-1 (TSSOP16)

DHVQFN16: plastic dual in-line compatible thermal enhanced very thin quad flat package; no leads; 16 terminals; body 2.5 x 3.5 x 0.85 mm

SOT763-1

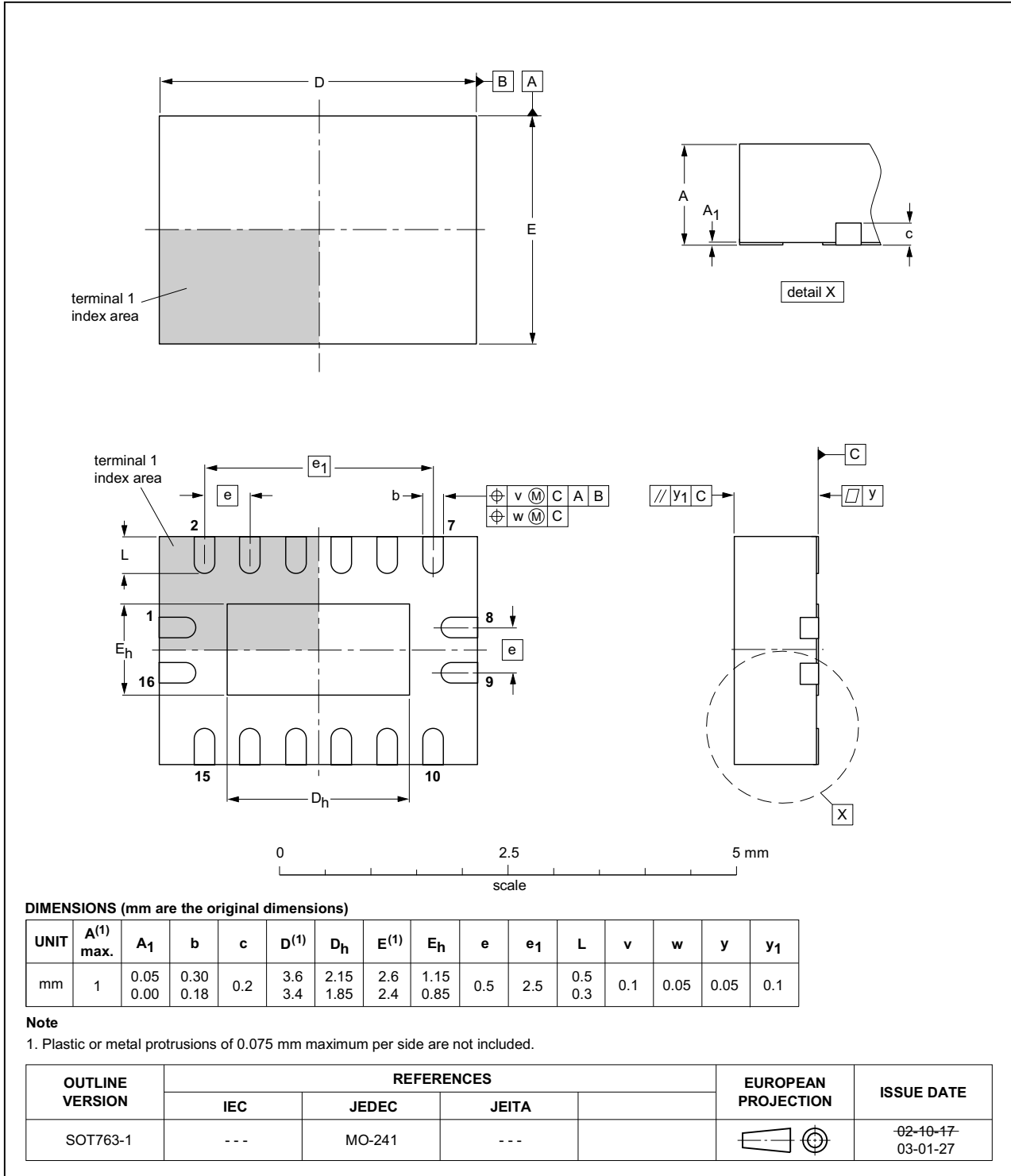

Fig 21. Package outline SOT763-1 (DHVQFN16)

## 15. Abbreviations

Table 9. Abbreviations

Acronym	Description
CMOS	Complementary Metal-Oxide Semiconductor
DUT	Device Under Test
ESD	ElectroStatic Discharge
HBM	Human Body Model
MM	Machine Model
TTL	Transistor-Transistor Logic

## 16. Revision history

Table 10. Revision history

Document ID	Release date	Data sheet status	Change notice	Supersedes
74HC_HCT4060 v.4	20160210	Product data sheet	-	74HC_HCT4060 v.3
Modifications:	<ul style="list-style-type: none"> <li>Type numbers 74HC4060N and 74HCT4060N (SOT38-4) removed.</li> <li><a href="#">Table 5</a>: HIGH and LOW input levels added for 74HCT4060. (errata)</li> </ul>			
74HC_HCT4060 v.3	20080714	Product data sheet	-	74HC_HCT4060_CNV v.2
Modifications:	<ul style="list-style-type: none"> <li>The format of this data sheet has been redesigned to comply with the new identity guidelines of NXP Semiconductors.</li> <li>Legal texts have been adapted to the new company name where appropriate.</li> <li><a href="#">Section 4</a>: DHVQFN16 package added.</li> <li><a href="#">Section 8</a>: derating values added for DHVQFN16 package.</li> <li><a href="#">Section 14</a>: outline drawing added for DHVQFN16 package.</li> </ul>			
74HC_HCT4060_CNV v.2	19970901	Product specification	-	-

## 17. Legal information

### 17.1 Data sheet status

Document status <sup>[1][2]</sup>	Product status <sup>[3]</sup>	Definition
Objective [short] data sheet	Development	This document contains data from the objective specification for product development.
Preliminary [short] data sheet	Qualification	This document contains data from the preliminary specification.
Product [short] data sheet	Production	This document contains the product specification.

[1] Please consult the most recently issued document before initiating or completing a design.

[2] The term 'short data sheet' is explained in section "Definitions".

[3] The product status of device(s) described in this document may have changed since this document was published and may differ in case of multiple devices. The latest product status information is available on the Internet at URL <http://www.nxp.com>.

### 17.2 Definitions

**Draft** — The document is a draft version only. The content is still under internal review and subject to formal approval, which may result in modifications or additions. NXP Semiconductors does not give any representations or warranties as to the accuracy or completeness of information included herein and shall have no liability for the consequences of use of such information.

**Short data sheet** — A short data sheet is an extract from a full data sheet with the same product type number(s) and title. A short data sheet is intended for quick reference only and should not be relied upon to contain detailed and full information. For detailed and full information see the relevant full data sheet, which is available on request via the local NXP Semiconductors sales office. In case of any inconsistency or conflict with the short data sheet, the full data sheet shall prevail.

**Product specification** — The information and data provided in a Product data sheet shall define the specification of the product as agreed between NXP Semiconductors and its customer, unless NXP Semiconductors and customer have explicitly agreed otherwise in writing. In no event however, shall an agreement be valid in which the NXP Semiconductors product is deemed to offer functions and qualities beyond those described in the Product data sheet.

### 17.3 Disclaimers

**Limited warranty and liability** — Information in this document is believed to be accurate and reliable. However, NXP Semiconductors does not give any representations or warranties, expressed or implied, as to the accuracy or completeness of such information and shall have no liability for the consequences of use of such information. NXP Semiconductors takes no responsibility for the content in this document if provided by an information source outside of NXP Semiconductors.

In no event shall NXP Semiconductors be liable for any indirect, incidental, punitive, special or consequential damages (including - without limitation - lost profits, lost savings, business interruption, costs related to the removal or replacement of any products or rework charges) whether or not such damages are based on tort (including negligence), warranty, breach of contract or any other legal theory.

Notwithstanding any damages that customer might incur for any reason whatsoever, NXP Semiconductors' aggregate and cumulative liability towards customer for the products described herein shall be limited in accordance with the *Terms and conditions of commercial sale* of NXP Semiconductors.

**Right to make changes** — NXP Semiconductors reserves the right to make changes to information published in this document, including without limitation specifications and product descriptions, at any time and without notice. This document supersedes and replaces all information supplied prior to the publication hereof.

**Suitability for use** — NXP Semiconductors products are not designed, authorized or warranted to be suitable for use in life support, life-critical or safety-critical systems or equipment, nor in applications where failure or malfunction of an NXP Semiconductors product can reasonably be expected to result in personal injury, death or severe property or environmental damage. NXP Semiconductors and its suppliers accept no liability for inclusion and/or use of NXP Semiconductors products in such equipment or applications and therefore such inclusion and/or use is at the customer's own risk.

**Applications** — Applications that are described herein for any of these products are for illustrative purposes only. NXP Semiconductors makes no representation or warranty that such applications will be suitable for the specified use without further testing or modification.

Customers are responsible for the design and operation of their applications and products using NXP Semiconductors products, and NXP Semiconductors accepts no liability for any assistance with applications or customer product design. It is customer's sole responsibility to determine whether the NXP Semiconductors product is suitable and fit for the customer's applications and products planned, as well as for the planned application and use of customer's third party customer(s). Customers should provide appropriate design and operating safeguards to minimize the risks associated with their applications and products.

NXP Semiconductors does not accept any liability related to any default, damage, costs or problem which is based on any weakness or default in the customer's applications or products, or the application or use by customer's third party customer(s). Customer is responsible for doing all necessary testing for the customer's applications and products using NXP Semiconductors products in order to avoid a default of the applications and the products or of the application or use by customer's third party customer(s). NXP does not accept any liability in this respect.

**Limiting values** — Stress above one or more limiting values (as defined in the Absolute Maximum Ratings System of IEC 60134) will cause permanent damage to the device. Limiting values are stress ratings only and (proper) operation of the device at these or any other conditions above those given in the Recommended operating conditions section (if present) or the Characteristics sections of this document is not warranted. Constant or repeated exposure to limiting values will permanently and irreversibly affect the quality and reliability of the device.

**Terms and conditions of commercial sale** — NXP Semiconductors products are sold subject to the general terms and conditions of commercial sale, as published at <http://www.nxp.com/profile/terms>, unless otherwise agreed in a valid written individual agreement. In case an individual agreement is concluded only the terms and conditions of the respective agreement shall apply. NXP Semiconductors hereby expressly objects to applying the customer's general terms and conditions with regard to the purchase of NXP Semiconductors products by customer.

**No offer to sell or license** — Nothing in this document may be interpreted or construed as an offer to sell products that is open for acceptance or the grant, conveyance or implication of any license under any copyrights, patents or other industrial or intellectual property rights.

**Export control** — This document as well as the item(s) described herein may be subject to export control regulations. Export might require a prior authorization from competent authorities.

**Non-automotive qualified products** — Unless this data sheet expressly states that this specific NXP Semiconductors product is automotive qualified, the product is not suitable for automotive use. It is neither qualified nor tested in accordance with automotive testing or application requirements. NXP Semiconductors accepts no liability for inclusion and/or use of non-automotive qualified products in automotive equipment or applications.

In the event that customer uses the product for design-in and use in automotive applications to automotive specifications and standards, customer (a) shall use the product without NXP Semiconductors' warranty of the product for such automotive applications, use and specifications, and (b) whenever customer uses the product for automotive applications beyond

NXP Semiconductors' specifications such use shall be solely at customer's own risk, and (c) customer fully indemnifies NXP Semiconductors for any liability, damages or failed product claims resulting from customer design and use of the product for automotive applications beyond NXP Semiconductors' standard warranty and NXP Semiconductors' product specifications.

**Translations** — A non-English (translated) version of a document is for reference only. The English version shall prevail in case of any discrepancy between the translated and English versions.

## 17.4 Trademarks

Notice: All referenced brands, product names, service names and trademarks are the property of their respective owners.

## 18. Contact information

For more information, please visit: <http://www.nxp.com>

For sales office addresses, please send an email to: [salesaddresses@nxp.com](mailto:salesaddresses@nxp.com)



## 19. Contents

---

<b>1</b>	<b>General description</b> .....	<b>1</b>
<b>2</b>	<b>Features and benefits</b> .....	<b>1</b>
<b>3</b>	<b>Applications</b> .....	<b>1</b>
<b>4</b>	<b>Ordering information</b> .....	<b>2</b>
<b>5</b>	<b>Functional diagram</b> .....	<b>2</b>
<b>6</b>	<b>Pinning information</b> .....	<b>4</b>
6.1	Pinning .....	4
6.2	Pin description .....	4
<b>7</b>	<b>Functional description</b> .....	<b>5</b>
<b>8</b>	<b>Limiting values</b> .....	<b>5</b>
<b>9</b>	<b>Recommended operating conditions</b> .....	<b>6</b>
<b>10</b>	<b>Static characteristics</b> .....	<b>6</b>
<b>11</b>	<b>Dynamic characteristics</b> .....	<b>10</b>
<b>12</b>	<b>Waveforms</b> .....	<b>12</b>
<b>13</b>	<b>RC oscillator</b> .....	<b>15</b>
13.1	Timing component limitations .....	15
13.2	Typical crystal oscillator circuit .....	15
<b>14</b>	<b>Package outline</b> .....	<b>18</b>
<b>15</b>	<b>Abbreviations</b> .....	<b>22</b>
<b>16</b>	<b>Revision history</b> .....	<b>22</b>
<b>17</b>	<b>Legal information</b> .....	<b>23</b>
17.1	Data sheet status .....	23
17.2	Definitions .....	23
17.3	Disclaimers .....	23
17.4	Trademarks .....	24
<b>18</b>	<b>Contact information</b> .....	<b>24</b>
<b>19</b>	<b>Contents</b> .....	<b>25</b>

---

Please be aware that important notices concerning this document and the product(s) described herein, have been included in section 'Legal information'.

---

© NXP Semiconductors N.V. 2016.

All rights reserved.

For more information, please visit: <http://www.nxp.com>

For sales office addresses, please send an email to: [salesaddresses@nxp.com](mailto:salesaddresses@nxp.com)

Date of release: 10 February 2016

Document identifier: 74HC\_HCT4060

# AMEYA360

## Components Supply Platform

Authorized Distribution Brand :



Website :

Welcome to visit [www.ameya360.com](http://www.ameya360.com)

Contact Us :

➤ Address :

401 Building No.5, JiuGe Business Center, Lane 2301, Yishan Rd  
Minhang District, Shanghai , China

➤ Sales :

Direct +86 (21) 6401-6692

Email [amall@ameya360.com](mailto:amall@ameya360.com)

QQ 800077892

Skype [ameyasales1](#) [ameyasales2](#)

➤ Customer Service :

Email [service@ameya360.com](mailto:service@ameya360.com)

➤ Partnership :

Tel +86 (21) 64016692-8333

Email [mkt@ameya360.com](mailto:mkt@ameya360.com)