

SERIES

PTxxxR PT

RoHS
Compliant

Traditional
First Quality

Power Toroids - Horizontal or Vertical Mount

MOUNTING AVAILABLE

IND. (μH) ±15% @ 1 kHz

DCR MAXIMUM (OHMS)

RATED IDC (AMPS)

FIG. "1" STANDARD VERTICAL

HORIZONTAL

FIG. "2" VERTICAL

FIG. "3" 2-LEAD VERTICAL

FIG. "4" 4-LEAD VERTICAL

DASH NUMBER*

Power Inductors

Inductance tested at 1 kHz, <10 gauss and 0 ADC

DC Resistance at 25°C

Rated Idc based on 40°C maximum rise from 25°C ambient with 0 Arms

Windings single layered to maximize operating frequency and minimize board space

Self leads solder coated to within 0.050" of seating plane

Other values available on request

Packaging Bulk only

Mounting Standard mounting is self-lead radial per Figure "1". Optional mounting methods are self-leaded horizontal per Figure "2" or vertical base mounted per Figures "3" and "4".

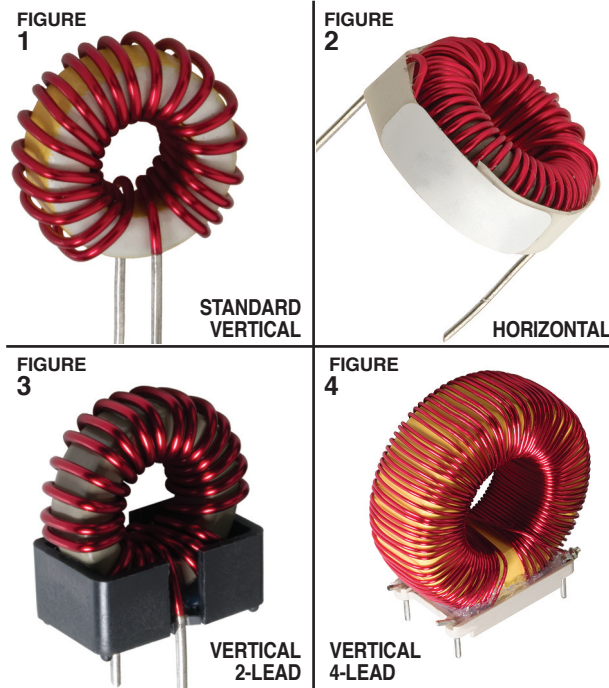

PT SERIES POWER TOROIDS							
Part #	Inductance (μH)	DCR (Ω)	Rated IDC (A)	Mounting	Mounting	Mounting	Mounting
PT5-530	5	0.015	6.1	•	•	•	
PT5-700	5	0.012	7.4	•	•	•	
PT5-800	5	0.010	10.6	•	•	•	
PT5-1000	5	0.008	12.8	•	•	•	
PT10-530	10	0.020	4.9	•	•	•	
PT10-680	10	0.015	6.8	•	•	•	
PT10-820	10	0.010	9.3	•	•	•	
PT10-990	10	0.008	13.2	•	•	•	
PT25-680	25	0.035	4.4	•	•	•	
PT25-800	25	0.025	6.6	•	•	•	
PT25-900	25	0.020	7.0	•	•	•	
PT25-1000	25	0.014	10.4	•	•	•	
PT50-780	50	0.050	3.8	•	•	•	
PT50-900	50	0.030	5.6	•	•	•	
PT50-1020	50	0.025	7.0	•	•	•	
PT50-1320	50	0.020	11.0	•	•	•	
PT75-900	75	0.060	3.9	•	•	•	
PT75-980	75	0.040	5.2	•	•	•	
PT75-1260	75	0.035	7.4	•	•	•	
PT75-1550	75	0.025	10.6	•	•	•	
PT100-1000	100	0.080	3.5	•	•	•	
PT100-1100	100	0.050	5.1	•	•	•	
PT100-1260	100	0.035	7.8	•	•	•	
PT100-1550	100	0.028	10.3	•	•	•	
PT150-1040	150	0.100	3.4	•	•	•	
PT150-1250	150	0.060	5.7	•	•	•	
PT150-1500	150	0.050	7.7	•	•	•	•
PT150-2050	150	0.040	12.3	•	•	•	•
PT250-1200	250	0.130	3.8	•	•	•	•
PT250-1500	250	0.080	6.1	•	•	•	•
PT250-1800	250	0.055	9.1	•	•	•	•
PT300-1200	300	0.150	3.3	•	•	•	•
PT300-1500	300	0.100	5.5	•	•	•	•
PT300-1750	300	0.075	7.3	•	•	•	•
PT400-1200	400	0.250	2.4	•	•	•	•
PT400-1500	400	0.180	4.7	•	•	•	•
PT400-1750	400	0.110	6.0	•	•	•	•
PT500-1450	500	0.220	3.4	•	•	•	•
PT500-1750	500	0.160	5.0	•	•	•	•
PT500-2000	500	0.090	8.0	•	•	•	•
PT750-1400	750	0.350	2.6	•	•	•	•
PT750-1700	750	0.280	3.7	•	•	•	•
PT750-2050	750	0.150	6.4	•	•	•	•
PT1000-1400	1000	0.620	1.8	•	•	•	•
PT1000-1750	1000	0.420	3.1	•	•	•	•
PT1000-2050	1000	0.200	5.9	•	•	•	•

*Complete part # must include series # PLUS the dash #

For surface finish information, refer to www.delevanfinishes.com

Notes to Figure 5 (Page 100) The PT Toroid Series inductance is specified at AC and DC signal levels which have no significant effect on the permeability of the powdered iron toroidal core. Superimposed AC and DC voltages will change the permeability and therefore the inductance, under operating conditions. Typically, DC currents will reduce the inductance, while AC signals will increase the inductance up to a point, before beginning to decrease. Supporting information is provided, detailing the AC or DC effects upon each part. Saturation resulting from DC currents is specified with waveform having less than a 1% ripple content. When considering the AC waveform, both the frequency and voltage level must be taken into account. As an aid in defining what effect the alternating sine wave signal will have, the voltage/frequency factor curve can be used. To determine what change of inductance can be expected at a given voltage level and frequency, simply divide the sinusoidal RMS voltage by the frequency. The voltage is in volts and the frequency is in hertz. As an example, if using part number PT25-680 at a 1VRMS signal level, and a frequency of 25KHz, the voltage/frequency factor is calculated to be: 1VRMS/25,000Hz = 40 x 10⁻⁶. Referring to the graph, a 39% increase in inductance would be expected.

Notes to Figure 6 (Page 100) Typical saturation effects as a function of DC flowing through the part. Data is representative of a DC waveform with less than 1% ripple, and an AC waveform less than 10 gauss.

Note This information is intended to be used in assisting the designer in part selection. Each operating application may contain other variables which must be considered in part selection; such as temperature effects, waveform distortion, etc.... Delevan Sales/Engineering staff is available to provide information as needed to fit each application.

PT SERIES (continued)

Power Toroids

ELECTRICAL **PHYSICAL PARAMETERS**

IND. (μH) ± 15% @ 1 kHz **RATED IDC (Amps)**

DCR MAX. (OHMS)

A Max. **B Max.** **C Nominal** **D Min.** **E Nominal** **F Nominal**

Inches **Inches** **Inches** **Inches** **Inches** **Inches**

mm **mm** **mm** **mm** **mm** **mm**

SERIES PT IRON CORE															
PT NUMBER	IND. (μH) ± 15% @ 1 kHz	DCR MAX. (OHMS)	RATED IDC (Amps)	A Max. Inches	A Max. mm	B Max. Inches	B Max. mm	C Nominal Inches	C Nominal mm	D Min. Inches	D Min. mm	E Nominal Inches	E Nominal mm	F Nominal Inches	F Nominal mm
PT5-530	5	0.015	6.1	0.53	13.46	0.23	5.84	0.17	4.32	0.50	12.7	0.025	0.64	0.450	11.43
PT5-700	5	0.012	7.4	0.70	17.78	0.33	8.38	0.24	6.10	0.50	12.7	0.032	0.81	0.600	15.24
PT5-800	5	0.010	10.6	0.80	20.32	0.36	9.14	0.31	7.87	0.50	12.7	0.040	1.02	0.720	18.30
PT5-1000	5	0.008	12.8	1.00	25.40	0.40	10.16	0.34	8.64	0.50	12.7	0.051	1.30	0.950	24.13
PT10-530	10	0.020	4.9	0.53	13.46	0.23	5.84	0.17	4.32	0.50	12.7	0.025	0.64	0.450	11.43
PT10-680	10	0.015	6.8	0.68	17.27	0.33	8.38	0.24	6.10	0.50	12.7	0.032	0.81	0.600	15.24
PT10-820	10	0.010	9.3	0.82	20.83	0.37	9.40	0.29	7.37	0.50	12.7	0.040	1.02	0.720	18.30
PT10-990	10	0.008	13.2	0.99	25.15	0.40	10.16	0.34	8.64	0.50	12.7	0.051	1.30	0.950	24.13
PT25-680	25	0.035	4.4	0.68	17.27	0.37	9.40	0.29	7.37	0.50	12.7	0.025	0.64	0.580	14.73
PT25-800	25	0.025	6.6	0.80	20.32	0.35	8.89	0.28	7.11	0.50	12.7	0.032	0.81	0.700	17.78
PT25-900	25	0.020	7.0	0.90	22.86	0.40	10.16	0.30	7.62	0.50	12.7	0.040	1.02	0.820	20.83
PT25-1000	25	0.014	10.4	1.00	25.40	0.40	10.16	0.37	9.40	0.50	12.7	0.051	1.30	0.950	24.13
PT50-780	50	0.050	3.8	0.78	19.81	0.36	9.14	0.27	6.86	0.50	12.7	0.025	0.64	0.680	17.27
PT50-900	50	0.030	5.6	0.90	22.86	0.38	9.65	0.30	7.62	0.50	12.7	0.032	0.81	0.790	20.07
PT50-1020	50	0.025	7.0	1.02	25.91	0.62	15.75	0.43	10.92	0.50	12.7	0.040	1.02	0.920	23.37
PT50-1320	50	0.020	11.0	1.32	33.53	0.63	16.00	0.53	13.46	0.50	12.7	0.051	1.30	1.220	30.99
PT75-900	75	0.060	3.9	0.90	22.86	0.36	9.14	0.29	7.37	0.50	12.7	0.025	0.64	0.770	19.56
PT75-980	75	0.040	5.2	0.98	24.89	0.38	9.65	0.30	7.62	0.50	12.7	0.032	0.81	0.890	22.61
PT75-1260	75	0.035	7.4	1.26	32.00	0.60	15.24	0.49	12.45	0.50	12.7	0.040	1.02	1.200	30.48
PT75-1550	75	0.025	10.6	1.55	39.37	0.64	16.26	0.53	13.46	0.50	12.7	0.051	1.30	1.500	38.10
PT100-1000	100	0.080	3.5	1.00	25.40	0.36	9.14	0.29	7.37	0.50	12.7	0.025	0.64	0.880	22.35
PT100-1100	100	0.050	5.1	1.10	27.94	0.50	12.70	0.42	10.67	0.50	12.7	0.032	0.81	0.890	22.61
PT100-1260	100	0.035	7.8	1.26	32.00	0.60	15.24	0.49	12.45	0.50	12.7	0.040	1.02	1.200	30.48
PT100-1550	100	0.028	10.3	1.55	39.37	0.64	16.26	0.53	13.46	0.50	12.7	0.051	1.30	1.500	38.10
PT150-1040	150	0.100	3.4	1.04	26.42	0.50	12.70	0.41	10.41	0.50	12.7	0.025	0.64	0.880	22.35
PT150-1250	150	0.060	5.7	1.25	31.75	0.58	14.73	0.48	12.19	0.50	12.7	0.032	0.81	1.160	29.46
PT150-1500	150	0.050	7.7	1.50	38.10	0.62	15.75	0.50	12.70	0.50	12.7	0.040	1.02	1.420	36.07
PT150-2050	150	0.040	12.3	2.05	52.07	0.92	23.37	0.80	20.32	0.50	12.7	0.051	1.30	2.000	50.80
PT250-1200	250	0.130	3.8	1.20	30.48	0.55	13.97	0.49	12.45	0.50	12.7	0.025	0.64	1.200	30.48
PT250-1500	250	0.080	6.1	1.50	38.10	0.60	15.24	0.50	12.70	0.50	12.7	0.036	0.91	1.450	36.83
PT250-1800	250	0.055	9.1	1.80	45.72	0.77	19.56	0.69	17.53	0.50	12.7	0.051	1.30	1.750	44.45
PT300-1200	300	0.150	3.3	1.20	30.48	0.55	13.97	0.48	12.19	0.50	12.7	0.025	0.64	1.200	30.48
PT300-1500	300	0.100	5.5	1.50	38.10	0.60	15.24	0.51	12.95	0.50	12.7	0.032	0.81	1.400	35.56
PT300-1750	300	0.075	7.3	1.75	44.45	0.76	19.30	0.65	16.51	0.50	12.7	0.045	1.14	1.750	44.45
PT400-1200	400	0.250	2.4	1.20	30.48	0.55	13.97	0.48	12.19	0.50	12.7	0.020	0.51	1.150	29.21
PT400-1500	400	0.180	4.7	1.50	38.10	0.60	15.24	0.50	12.70	0.50	12.7	0.025	0.64	1.400	35.56
PT400-1750	400	0.110	6.0	1.75	44.45	0.78	19.81	0.70	17.78	0.50	12.7	0.040	1.02	1.750	44.45
PT500-1450	500	0.220	3.4	1.45	36.83	0.58	14.73	0.50	12.70	0.50	12.7	0.025	0.64	1.400	35.56
PT500-1750	500	0.160	5.0	1.75	44.45	0.75	19.05	0.62	15.75	0.50	12.7	0.036	0.91	1.700	43.18
PT500-2000	500	0.090	8.0	2.05	52.07	0.88	22.35	0.76	19.30	0.50	12.7	0.045	1.14	2.000	50.80
PT750-1400	750	0.350	2.6	1.40	35.56	0.55	13.97	0.48	12.19	0.50	12.7	0.020	0.51	1.400	35.56
PT750-1700	750	0.280	3.7	1.70	43.18	0.70	17.78	0.62	15.75	0.50	12.7	0.025	0.64	1.660	42.16
PT750-2050	750	0.150	6.4	2.05	52.07	0.85	21.59	0.78	19.81	0.50	12.7	0.036	0.91	2.000	50.80
PT1000-1400	1000	0.620	1.8	1.40	35.56	0.55	13.97	0.48	12.19	0.50	12.7	0.016	0.41	1.360	34.54
PT1000-1750	1000	0.420	3.1	1.75	44.45	0.70	17.78	0.62	15.75	0.50	12.7	0.025	0.64	1.660	42.16
PT1000-2050	1000	0.200	5.9	2.05	52.07	0.85	21.59	0.78	19.81	0.50	12.7	0.032	0.81	2.000	50.80

Note: Vertical configuration is standard; add suffix "HM" for horizontal mounting

FIGURE 1: STANDARD VERTICAL MOUNT

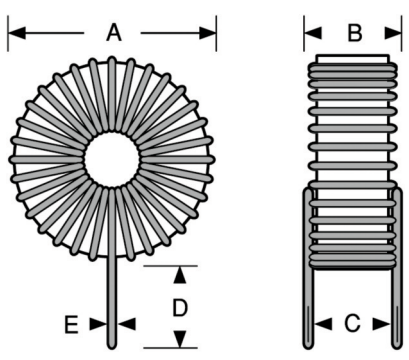
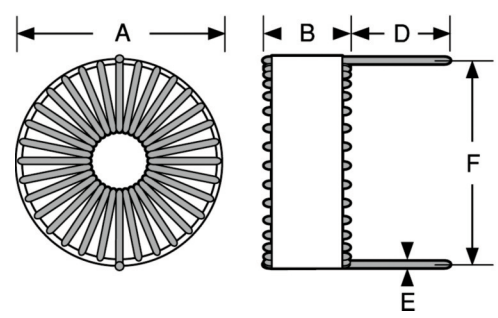

FIGURE 2: HORIZONTAL MOUNT



PT SERIES (continued)

Power Inductors

Power Toroids

PART NUMBER	ELECTRICAL		PHYSICAL PARAMETERS													
	IND. (μH) ± 15% @ 1 kHz	DCR MAX. (OHMS)	RATED IDC (Amps)	FIGURE#	A Max. Inches	A Max. mm	B Max. Inches	B Max. mm	C Typical Inches	C Typical mm	D Typical Inches	D Typical mm	E Max. Inches	E Max. mm	F Typical Inches	F Typical mm
SERIES PT VERTICAL MOUNT IRON CORE																
PT5-530-VM	5	0.015	6.1	3	0.580	14.73	0.340	8.64	0.220	5.59	0.025	0.63	0.640	16.26	0.290	7.37
PT5-700-VM	5	0.012	7.4	3	0.650	16.51	0.450	11.43	0.300	7.62	0.032	0.81	0.810	20.57	0.325	8.25
PT5-800-VM	5	0.010	10.6	3	0.830	21.08	0.450	11.43	0.300	7.62	0.040	1.02	0.910	23.11	0.415	10.54
PT10-530-VM	10	0.020	4.9	3	0.580	14.73	0.340	8.64	0.220	5.59	0.025	0.63	0.640	16.26	0.290	7.37
PT10-680-VM	10	0.015	6.8	3	0.650	16.51	0.450	11.43	0.300	7.62	0.032	0.81	0.790	20.07	0.325	8.25
PT10-820-VM	10	0.010	9.3	3	0.830	21.08	0.450	11.43	0.300	7.62	0.040	1.02	0.930	23.62	0.415	10.54
PT25-680-VM	25	0.035	4.4	3	0.650	16.51	0.450	11.43	0.300	7.62	0.025	0.63	0.790	20.07	0.325	8.25
PT25-800-VM	25	0.025	6.6	3	0.830	21.08	0.450	11.43	0.300	7.62	0.032	0.81	0.910	23.11	0.415	10.54
PT25-900-VM	25	0.020	7.0	3	0.950	24.13	0.600	15.24	0.450	11.43	0.040	1.02	1.010	25.65	0.475	12.06
PT50-780-VM	50	0.050	3.8	3	0.830	21.08	0.450	11.43	0.300	7.62	0.025	0.63	0.890	22.61	0.415	10.54
PT50-900-VM	50	0.030	5.6	3	0.830	21.08	0.450	11.43	0.300	7.62	0.032	0.81	1.110	28.19	0.415	10.54
PT50-1020-VM	50	0.025	7.0	3	1.250	31.75	0.700	17.78	0.500	12.70	0.040	1.02	1.130	28.70	0.625	15.87
PT75-900-VM	75	0.060	3.9	3	0.950	24.13	0.600	15.24	0.450	11.43	0.025	0.63	1.010	25.65	0.475	12.06
PT75-980-VM	75	0.040	5.2	3	0.950	24.13	0.600	15.24	0.450	11.43	0.032	0.81	1.090	27.69	0.475	12.06
PT75-1260-VM	75	0.035	7.4	3	1.250	31.75	0.700	17.78	0.500	12.70	0.040	1.02	1.390	35.31	0.625	15.87
PT100-1000-VM	100	0.080	3.5	3	0.950	24.13	0.600	15.24	0.450	11.43	0.025	0.63	1.130	28.70	0.475	12.06
PT100-1100-VM	100	0.050	5.1	3	0.950	24.13	0.600	15.24	0.450	11.43	0.032	0.81	1.230	31.24	0.475	12.06
PT100-1260-VM	100	0.035	7.8	3	1.250	31.75	0.700	17.78	0.500	12.70	0.040	1.02	1.390	35.31	0.625	15.87
PT150-1040-VM	150	0.100	3.4	3	0.950	24.13	0.600	15.24	0.450	11.43	0.025	0.63	1.170	29.72	0.475	12.06
PT150-1250-VM	150	0.060	5.7	3	1.250	31.75	0.700	17.78	0.500	12.70	0.032	0.81	1.380	35.05	0.625	15.87
PT150-1500-VM	150	0.050	7.7	4	1.500	38.10	0.800	20.32	0.600	15.24	0.050	1.27	1.630	41.40	0.900	22.86
PT250-1200-VM	250	0.130	3.8	3	1.250	31.75	0.700	17.78	0.500	12.70	0.025	0.63	1.330	33.78	0.625	15.87
PT250-1500-VM	250	0.080	6.1	4	1.500	38.10	0.800	20.32	0.600	15.24	0.050	1.27	1.630	41.40	0.900	22.86
PT300-1200-VM	300	0.150	3.3	3	1.250	31.75	0.700	17.78	0.500	12.70	0.025	0.63	1.330	33.78	0.625	15.87
PT300-1500-VM	300	0.100	5.5	4	1.500	38.10	0.800	20.32	0.600	15.24	0.050	1.27	1.630	41.40	0.900	22.86
PT400-1200-VM	400	0.250	2.4	3	1.250	31.75	0.700	17.78	0.500	12.70	0.020	0.51	1.330	33.78	0.625	15.87
PT400-1500-VM	400	0.180	4.7	4	1.500	38.10	0.800	20.32	0.600	15.24	0.050	1.27	1.630	41.40	0.900	22.86
PT400-1750-VM	400	0.110	6.0	4	1.750	44.45	0.900	22.86	0.700	17.78	0.050	1.27	1.880	47.75	1.200	30.48
PT500-1450-VM	500	0.220	3.4	4	1.450	36.83	0.800	20.32	0.600	15.24	0.050	1.27	1.580	40.13	0.900	22.86
PT500-1750-VM	500	0.160	5.0	4	1.750	44.45	0.900	22.86	0.700	17.78	0.050	1.27	1.880	47.75	1.200	30.48
PT750-1400-VM	750	0.350	2.6	4	1.400	35.56	0.800	20.32	0.600	15.24	0.050	1.27	1.530	38.86	0.900	22.86
PT750-1700-VM	750	0.280	3.7	4	1.700	43.18	0.900	22.86	0.700	17.78	0.050	1.27	1.830	46.48	1.200	30.48
PT750-2050-VM	750	0.150	6.4	4	2.050	52.07	0.900	22.86	0.700	17.78	0.050	1.27	2.180	55.37	1.200	30.48
PT1000-1400-VM	1000	0.620	1.8	4	1.400	35.56	0.800	20.32	0.600	15.24	0.050	1.27	1.530	38.86	0.900	22.86
PT1000-1750-VM	1000	0.420	3.1	4	1.750	44.45	0.900	22.86	0.700	17.78	0.050	1.27	1.980	50.29	1.200	30.48
PT1000-2050-VM	1000	0.200	5.9	4	2.050	52.07	0.900	22.86	0.700	17.78	0.050	1.27	2.180	55.37	1.200	30.48

FIGURE 3: 2-LEAD VERTICAL BASE MOUNT

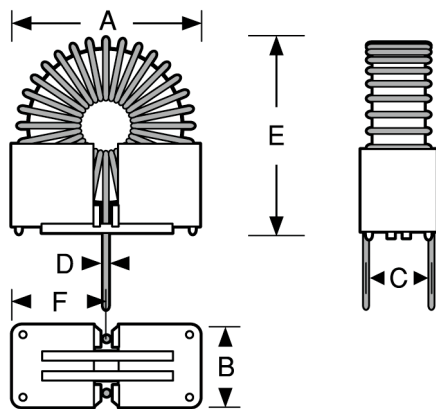
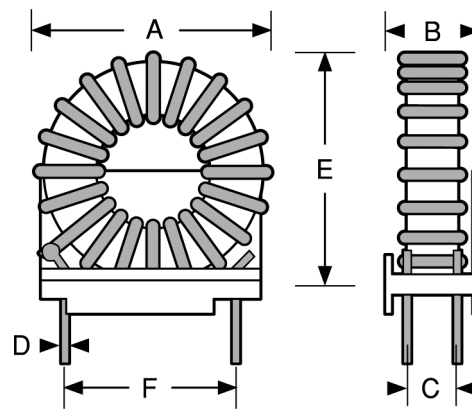
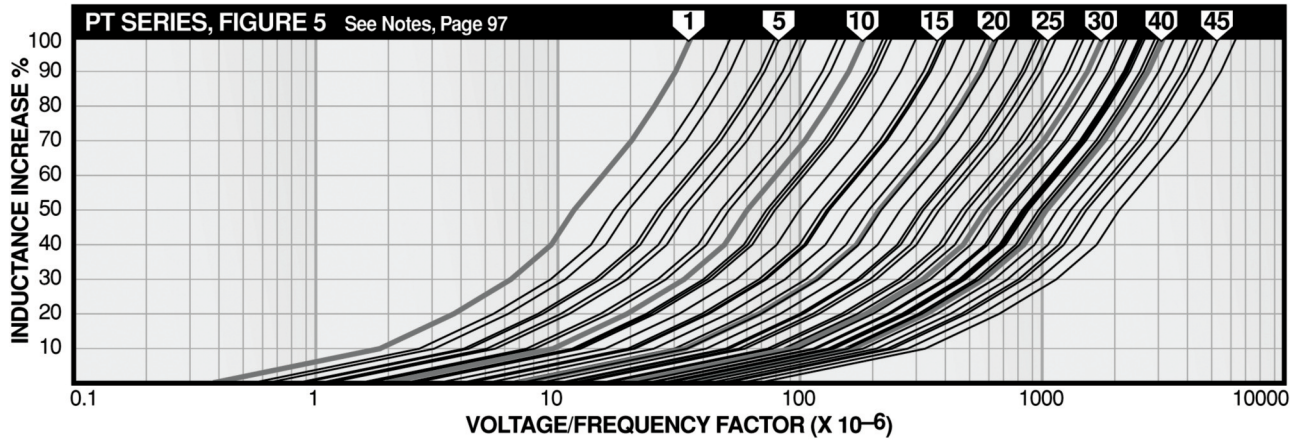

FIGURE 4: 4-LEAD VERTICAL BASE MOUNT



Power Toroids - Horizontal or Vertical Mount



KEY TO FIGURE 5 CURVE NUMBERS Graphs apply to all mounting styles. For more detailed graphs, contact factory.

- | | | | | | | | |
|-------------|---------------|----------------|----------------|----------------|----------------|-----------------|-----------------|
| 1) PT5-530 | 7) PT10-820 | 13) PT50-780 | 19) PT100-1100 | 25) PT100-1550 | 31) PT400-1200 | 37) PT500-1450 | 43) PT500-2000 |
| 2) PT10-530 | 8) PT10-990 | 14) PT50-900 | 20) PT50-1320 | 26) PT150-1250 | 32) PT300-1500 | 38) PT400-1750 | 44) PT1000-1750 |
| 3) PT5-700 | 9) PT25-680 | 15) PT75-900 | 21) PT150-1040 | 27) PT150-1500 | 33) PT400-1500 | 39) PT750-1400 | 45) PT750-2050 |
| 4) PT5-800 | 10) PT25-800 | 16) PT75-980 | 22) PT75-1260 | 28) PT250-1200 | 34) PT250-1800 | 40) PT500-1750 | 46) PT1000-2050 |
| 5) PT10-680 | 11) PT25-900 | 17) PT50-1020 | 23) PT100-1260 | 29) PT300-1200 | 35) PT150-2050 | 41) PT1000-1400 | |
| 6) PT5-1000 | 12) PT25-1000 | 18) PT100-1000 | 24) PT75-1550 | 30) PT250-1500 | 36) PT300-1750 | 42) PT750-1750 | |

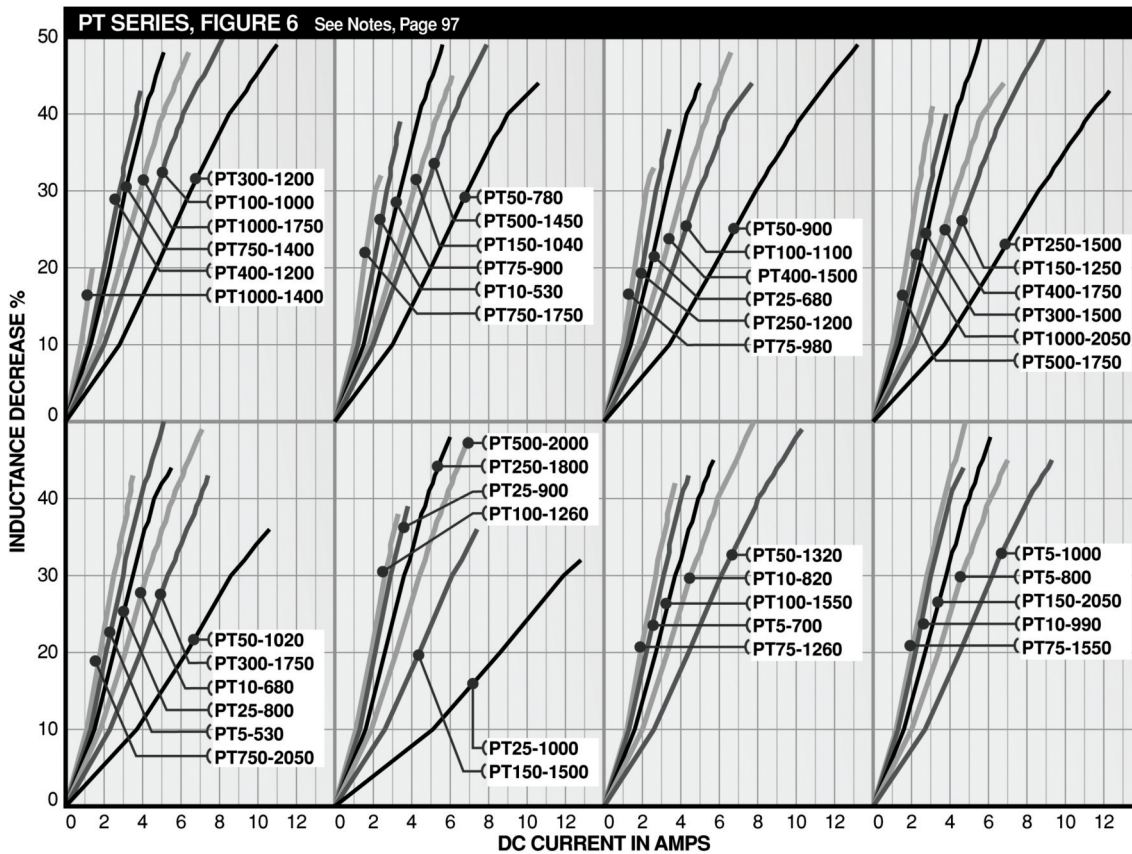

For more detailed graphs, contact factory



AMEYA360

Components Supply Platform

Authorized Distribution Brand :



Website :

Welcome to visit www.ameya360.com

Contact Us :

➤ Address :

401 Building No.5, JiuGe Business Center, Lane 2301, Yishan Rd
Minhang District, Shanghai , China

➤ Sales :

Direct +86 (21) 6401-6692

Email amall@ameya360.com

QQ 800077892

Skype [ameyasales1](#) [ameyasales2](#)

➤ Customer Service :

Email service@ameya360.com

➤ Partnership :

Tel +86 (21) 64016692-8333

Email mkt@ameya360.com