

ST7 SOFTWARE LIBRARY

USER MANUAL

November 2005



USE IN LIFE SUPPORT DEVICES OR SYSTEMS MUST BE EXPRESSLY AUTHORIZED.

STMicroelectronics PRODUCTS ARE NOT AUTHORIZED FOR USE AS CRITICAL COMPONENTS IN LIFE SUPPORT DEVICES OR SYSTEMS WITHOUT THE EXPRESS WRITTEN APPROVAL OF STMicroelectronics. As used herein:

1. Life support devices or systems are those which (a) are intended for surgical implant into the body, or (b) support or sustain life, and whose failure to perform, when properly used in accordance with instructions for use provided with the product, can be reasonably expected to result in significant injury to the user.

2. A critical component is any component of a life support device or system whose failure to perform can reasonably be expected to cause the failure of the life support device or system, or to affect its safety or effectiveness.



1 INTRODUCTION

This document describes the features, the files structure, examples, module drivers and guidelines for using the ST7 software library package.

1.1 ABBREVIATIONS USED

• SCI	Serial Communication Interface
• ADC	Analog to Digital Converter
• SPI	Serial peripheral Interface
• I2C	Inter Integrated Circuit
• CAN	Controller Area Network
• WDG	Watchdog
• EEPROM	Electrically Erasable Prog. Read Only Memory
• ITC	Interrupt Controller
• I/O	Input/Output Ports
• PWM	Pulse Width Modulation
• ART	Auto Reload Timer
• TBU	Time Base Unit
• TIMER	16-bit Timer
• TIMER8	8-bit Timer
• LT	Lite Timer
• LART	Lite Auto Reload Timer
• STVD7	ST Visual Debug 7
• MCD	Microcontroller Division

1.2 NAMING CONVENTIONS

Periph. All names starting with Periph are referring to the name of the peripheral.

Table of Contents

1 INTRODUCTION	3
1.1 ABBREVIATIONS USED	3
1.2 NAMING CONVENTIONS	3
2 OVERVIEW	7
2.1 FUNCTIONAL SCOPE	7
2.2 FEATURES	7
3 GETTING STARTED WITH TOOLS	8
3.1 SOFTWARE TOOLS	8
3.2 HARDWARE TOOLS	8
3.3 TECHNICAL LITERATURE	8
3.4 HOW TO INSTALL THE LIBRARY	9
4 LIBRARY STRUCTURE	10
4.1 ST7_LIBX	10
4.2 ST7LIB_CONFIG.H	10
4.2.1 User part of the ST7lib_config.h	11
4.2.2 Non-User part of the ST7lib_config.h	11
4.3 PERIPHERALS LIBRARY	11
4.3.1 Peripherals directory	11
4.3.2 Periph directory	11
4.3.2.1 C directory	12
4.4 DEVICES	12
4.5 DOCUMENTATION	13
4.6 DEMO	13
5 EXAMPLE	14
5.1 SOURCES FOLDER	14
5.2 WORKSPACE	15
5.2.1 STVD7_2x	15

Table of Contents

5.2.2	STVD7_3x	15
5.2.3	winIDEA (only for ST72F561 and CAN peripheral)	15
6	HOW TO USE THE LIBRARY	16
6.1	STANDARD PROCEDURE FOR ALL PERIPHERALS	16
6.2	USING THE COMMUNICATION PERIPHERALS LIBRARY	17
6.2.1	SCI	17
6.2.2	SPI	18
6.2.3	I2C	19
6.2.4	CAN	21
6.2.4.1	DESCRIPTION	22
6.2.4.2	DATA STRUCTURES	22
6.2.4.3	DATA TYPES	23
6.2.4.4	MEMORY USAGE	23
6.2.4.5	PARAMETER CONFIGURATION	23
6.2.4.6	Tx & Rx BUFFER USAGE	25
6.2.4.7	IMPLEMENTATION HINTS	25
6.3	OTHER PERIPHERALS	26
6.3.1	TIMER	26
6.3.2	I/O	26
6.4	MEMORY MODELS	26
6.5	PORTING APPLICATIONS FROM LIBRARY VERSION 1.0	26
7	PRESENTATION OF LIBRARY FUNCTIONS	27
7.1	LIBRARY REFERENCES	27
8	RELEASE INFORMATION	28
8.1	PERIPHERALS	28
8.2	DEVICES	29
9	FUNCTION DESCRIPTIONS	30
9.1	GENERAL PURPOSE PERIPHERALS	30
9.1.1	ADC	30
9.1.2	SCI	34
9.1.3	SPI	59
9.1.4	I2C MASTER	81
9.1.5	I2C SLAVE	107

Table of Contents

9.1.6	16-bit TIMER (TIMER)	124
9.1.7	8-bit TIMER (TIMER8)	137
9.1.8	LITE TIMER (LT)	150
9.1.9	PWMART	159
9.1.10	LITE AUTO-RELOAD TIMER (LART)	171
9.1.11	TBU	187
9.1.12	WDG	192
9.1.13	ITC	196
9.1.14	MCC	208
9.1.15	EEPROM	214
9.1.16	I/O	219
9.2	APPLICATION SPECIFIC PERIPHERALS	227
9.2.1	CAN LIBRARY FUNCTION LIST	227
9.2.1.1	Initialization-Services	227
9.2.1.2	Transmit-Services	228
9.2.1.3	Sleep/Wakeup Services	230
9.2.1.4	Status Information Service	231
9.2.1.5	Transmit/Receive Task Services	231
9.2.1.6	Interrupt Services	232
10	APPENDIX A	233
10.1	SUPPORTED DEVICES AND THEIR PERIPHERALS	233
11	REVISION HISTORY	234

2 OVERVIEW

2.1 FUNCTIONAL SCOPE

ST7 library is a software package consisting of device drivers for all standard ST7 peripherals. Each device driver has a set of functions covering the functionality of the peripheral. The source code, developed in 'C' is fully documented and thoroughly tested.

This library has been developed to make it easy for you to develop ST7 applications. A basic knowledge of C programming is required. With ST7 library, you can use any ST7 device in your application without having to study each peripheral specification in-depth. As a result, using this library can save you a lot of coding time and save part of the cost of developing and integrating your application.

2.2 FEATURES

- NEW: Supports new devices ST72325 and ST7232A
- NEW: Provided workspace for both STVD7 version 3.x and 2.x
- The ST7 library package consists of device driver library files, the configuration and setup files.
- With each peripheral, application example code is provided. This is an application tailored to a specific ST7 device, which uses the library functions to drive the peripheral. You can use it without modification in an ST development kit.
- A detailed function reference is provided for each peripheral
- The functional behaviour and input/output parameters of each function are described in detail in the user manual
- The functions are coded in 'C' and are compatible with Metrowerks & Cosmic compilers
- The ST7 library is MISRA compliant
- Registry Key is added to provide information on installation path and version

3 GETTING STARTED WITH TOOLS

3.1 SOFTWARE TOOLS

The library functions have been debugged with the ST7 software toolset. The ST7 software toolset can be found on the MCU CD-ROM or can be downloaded from the ST website:

<http://www.st.com/mcu>

The following versions of the C compilers are used:

- METROWERKS C toolchain version 4.2.5
- COSMIC C toolchain version 4.4d

A valid license has to be purchased for Metrowerks and Cosmic compilers. Free versions with code limitations may also be available, check the websites of the two providers for further information.

Note: Since Metrowerks was previously known as Hiware, both C compilers are compatible.

3.2 HARDWARE TOOLS

Hardware tools are not required for using the library, you can use the STVD7 simulator if it supports the target device (check with the latest device documentation). However you can use the following Hardware tools for development support:

- ICD based debugging tools (like InDart from Softec or R-Link ST from Raisonance)
- ST Emulators (EMU or DVP)
- ST7232x - SK/ RAIS (Starter Kit by Raisonance)
- ST evaluation boards / starter kits (for example ST7232x-EVAL)
- ST7-STICK - ST in-circuit communication kits
- ICC socket boards - these complement any tool that has ICC programming capabilities (like ST7-STICK, InDART, R-Link, DVP, EMU, etc.)
- Third party emulators (from Hitex or iSYSTEM)
- Engineering Programming Board (EPB) or Gang Programmer

3.3 TECHNICAL LITERATURE

As well as reading the ST7 device datasheet, you should also read the following documents before using the library. All the documents and the device datasheets are available on the ST website and on the MCU CD ROM.

ST7 Software library user manual

Application note: AN978: Key features of the STVD7 ST7 Visual debug package

Application note: AN989: Getting started with the ST7 Hiware C Toolchain

Application note: AN983: Key features of the Cosmic ST7 C- Compiler package

Application note: AN1064: Writing Optimized Hiware C Language for ST7

Application note: AN1938: Visual Develop for ST7 Cosmic C Toolset Users

Application note: AN1939: Visual Develop for ST7 Metrowerks C Toolset Users

3.4 HOW TO INSTALL THE LIBRARY

The library is supplied in a zip package. Extraction of this zip file will give the setup file ST7LibxSetup.exe, where x represents the latest numeric version of the library. Click on the setup file to install the library on the host system.

4 LIBRARY STRUCTURE

4.1 ST7_LIBX

Location: \Root directory

Description: The ST7_libx (where x represents the latest numeric version of the library) is installed by default in the root directory. It is comprised of five main components: the ST7library configuration file, the Peripherals (Device driver) library folder, the devices configuration files folder, documentation on the package and the demo folder. The location of these components is described in this section and shown in the figure given below.

Note: The Example directory is shown in [Figure 2 on page 14](#).

Figure 1. Main Directory structure

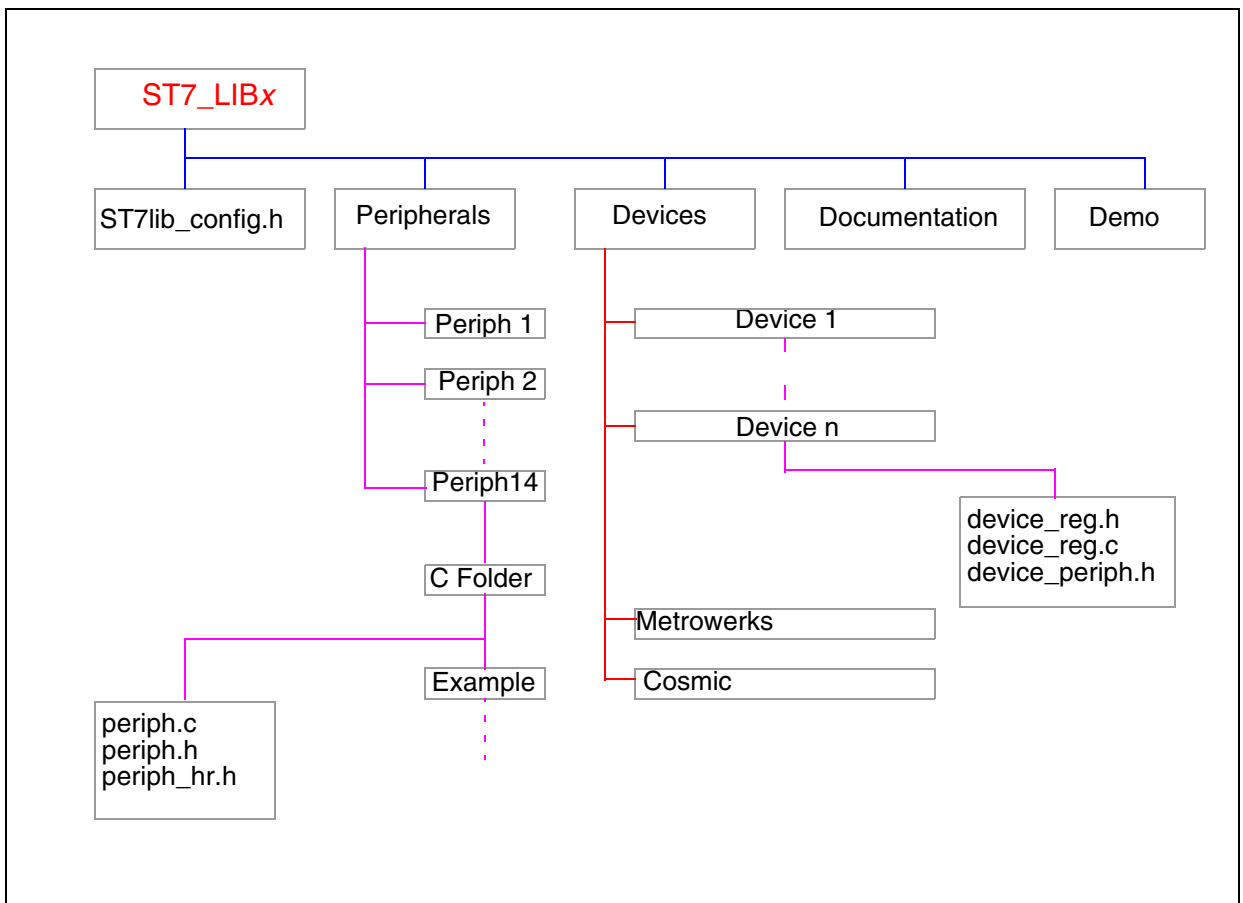

4.2 ST7LIB_CONFIG.H

Location: ST7_libx\ST7lib_config.h

Description: ST7lib_config.h is the entry point for the user. You have to include this file in your application (main.c). This file is used to define specific labels for example, to define the mode of transmission of communication peripherals, cpu frequency, etc.

St7lib_config.h is divided into two major sections:

4.2.1 User part of the ST7lib_config.h

- You can customize this portion to your application requirement
- You can define your own labels and macros here
- You can change the CPU clock value (default is 8MHz)
- For the ST72F264 device you can select whether to use Port C as ei0 or ei1
- The target ST7 device file (st72xxx_periph.h) has to be included in this file

Note: An error message “No Valid ST7 MCU Configuration” will be generated by the compiler if no device file has been included.

4.2.2 Non-User part of the ST7lib_config.h

This part contains the labels for METROWERKS and COSMIC compilers. It contains the compiler definitions as follows:

```
#if (defined __HIWARE__ | defined __MWERKS__ )
#define _HIWARE_
#else
#ifdef __CSMC__
#define _COSMIC_
#else #error "Unsupported Compiler!" /* Compiler defines not found */
#endif
#endif
```

The labels `__MWERKS__` (`__HIWARE__`) and `__CSMC__` are automatically set by the Metrowerks and cosmic compilers respectively. If none of these two compilers are selected then an error message “Unsupported Compiler!” appears on the debugger window.

Macros definitions in ST7lib_config.h:

ST7lib_Config.h file also contains a list of macros. They are as follows.

1. EnableInterrupts: You can use this macro to reset the interrupt mask, this macro is equivalent to the RIM instruction in assembly.
2. Nop: No operation. This is equivalent to the nop instruction in assembly
3. DisableInterrupts: You can use this macro to set the interrupt mask, this macro is equivalent to the SIM instruction in assembly.
4. WaitForInterrupt: This is equivalent to the “wfi” instruction in assembly.

4.3 PERIPHERALS LIBRARY

4.3.1 Peripherals directory

Location: ST7_lib\Peripherals

Description: This directory contains subdirectories by the name of the peripheral.

Subdirectory names: ADC, EEPROM, I2C, I2CSlave, IO, ITC, LART, LT, MCC, PWMART, SCI, SPI, TBU, TIMER, TIMER8, WDG, CAN.

4.3.2 Periph directory

Location: ST7_lib\Peripherals\Periph\sources

Description: Each subdirectory contains a 'C' sub folder which contains peripheral library files.

4.3.2.1 C directory

Location: ST7_lib\Peripherals\Periph\sources\C

Description: Each subdirectory contains the source files, header files and an example folder showing the usage of the functions.

Files: Periph.c, Periph.h, Periph_hr.h

Periph.c

Inclusion of periph_hr.h, periph.h, ST7lib_config.h. It contains the Peripheral functions with some conditional compilation options.

Periph.h:

This contains the (typedef enum) parameters for each peripheral, prototypes of functions defined in Peripheral.c and definition of Peripheral constant definitions.

Periph_hr.h

This file contains the bit mapping of the hardware registers used for the peripherals.

4.4 DEVICES

Location: ST7_LIB\Devices

Description:

1. Contains the files which define all registers for each device and includes the file which is used to select peripherals for the application. This register file is included in the ST7lib_config.h.

The folder ST7_LIB\Devices\ST7xx contains st7xx_reg.h, st7xx_reg.c and st7xx_periph.h files.

st7xx_reg.h: This file contains a declaration of the register variables of st7xx for Metrowerks and definitions of the register variables for the Cosmic compiler.

st7xx_reg.c: This file contains definitions of the register variables of st7xx device.

st7xx_periph.h: This file is used to select which peripherals of st7xx device are used in the application.

2. Contains the generic configuration files both Metrowerks and Cosmic compilers.

Metrowerks: Contains the mapping file (ST72xxx.prm) for all the hardware registers in device, Make file (ST72xxx.mak) to build the application and the default.env which defines all the useful paths and options for the application.

COSMIC: make file to build the application (ST72xxx.mak), link file (ST72xxx.lkf) used to link the device and the interrupt mapping file (vector_xxx.c) for the target device.

Notes:

1. This software covers 13 main devices and their subsets. You have to include the file from the main device section in order to support the related subsets.
2. The register files in the ST7 library are different from those provided with the STVD7 ver 3.x. Take care to include the correct one.

Table 1. Supported devices

Main device	Subsets
ST72F62	ST72F621, ST72F622, ST72F623, ST72F611
ST72F63B	ST72F63BK1, ST72F63BK2, ST72F63BK3
ST72F65	ST72F65
ST72F521	ST72F521, ST72F321, ST72F324
ST72325	ST72F325(C/J/K)4, ST72F325(AR/C/J/K)6/7/9
ST7232A	ST72F32AK2
ST7FLITE0	ST7FLITE05, ST7FLITE09
ST7FLITE1	ST7FLITE10, ST7FLITE15, ST7FLITE19, ST7FLITE1B
ST7FLITE2	ST7FLITE20, ST7FLITE25, ST7FLITE29
ST7FLITE3	ST7FLITE3
ST72F264	ST72F260G1, ST72F262G1, ST72F262G2, ST72F264G1, ST72F264G2
ST72F561	ST72F561(R/J/K)9, ST72F561(R/J/K)6
ST7SUPERLITE	ST7FLITES2, ST7FLITES5

4.5 DOCUMENTATION

Location: ST7_LIB\Documentation

Description: This directory contains the global user manual describing each peripheral library and its use in detail.

Files: user manual.pdf

4.6 DEMO

Location: ST7_LIB\DEMO

Description: This directory contains an application program which demonstrates the use of the ST7LIB on the devices ST72F521, ST72F62, ST7FLITE0, ST7FLITE2, ST7SUPERLITE, ST72F561 and ST72325. The program uses all the peripheral libraries together for a particular application. The purpose of the demo is to help to develop an application using the software library.

5 EXAMPLE

Location: ST7_LIB\Peripherals\Periph\sources\C\Example

Description: Contains the example application code for each peripheral individually. The code has been developed using the peripheral library functions exercises the functionality of that peripheral. The configuration and workspace has been provided for users of both STVD7 ver2.x and 3.x. The example has been compiled and tested using both Metrowerks and Cosmic compilers and configuration files are provided.

Subdirectories: Sources, workspace

Figure 2. Example directory structure

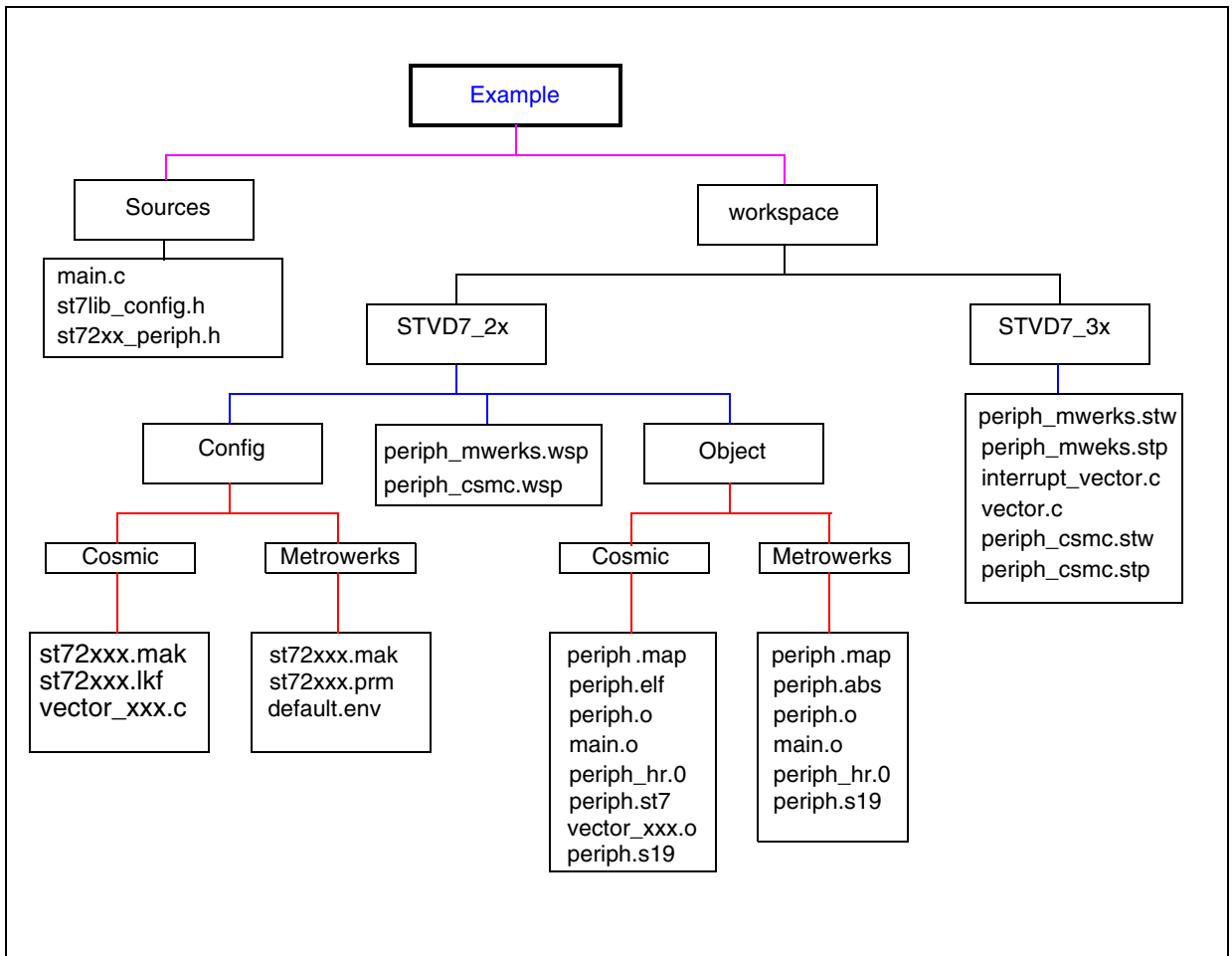

5.1 SOURCES FOLDER

Description: Contains the ST7lib_config.h, the main application file and the peripheral source files needed to run the application

5.2 WORKSPACE

This folder contains configuration and workspace files for both STVD7 ver2.x and 3.x as per the directory structure shown in figure 2.

Note:

1. For ST72F561 demo and CAN peripheral, winIDEA workspace is also available.
2. For ST72325 and ST7232A demo STVD7_3X workspace is only available.

5.2.1 STVD7_2x

This folder contains relevant configuration files for ST7 Visual Debug ver 2.x. Subdirectories: Config, Object

Config Folder: Contains the configuration files for both Metrowerks and Cosmic compilers.

metrowerks: Contains the mapping file (ST72xxx.prm) for all the hardware registers in the device, the Make file (ST72xxx.mak) for building the application and the default.env file which defines all the useful paths names and options for the application.

COSMIC: Contains the make file for building the application (ST72xxx.mak), the link file (ST72xxx.lkf) used to link the device and the interrupt mapping file (vector_xxx.c) for the target device.

Object Folder:

These folders are used for temporary storage of object and executable files generated by the compiler in respective directories - metrowerks and cosmic.

5.2.2 STVD7_3x

This folder contains relevant Cosmic and Metrowerks workspace for ST7 Visual Debug ver 3.X, as the configuration files are automatically generated.

5.2.3 winIDEA (only for ST72F561 and CAN peripheral)

This folder contains relevant configuration files for winIDEA.

Subdirectories: Config, Object

For details related to Subdirectories refer to [Section 5.2.1](#)

6 HOW TO USE THE LIBRARY

The next section gives the standard procedure to be followed for all the peripherals. Some specific instructions are given in the section 7.2 which have to be followed if you use the communication peripherals.

6.1 STANDARD PROCEDURE FOR ALL PERIPHERALS

Note: This section is only applicable if you are using STVD7 v2.x.

1. Install ST7_LIBx in one directory as per the installation procedure.
2. When starting for the first time, copy the structure from the demo directory.
3. Choose the target device and copy the configuration files (for Metrowerks or Cosmic) from the devices directory into the user configuration directory.
4. Update the useful paths and link the chosen peripherals files. The source path will refer to the directory where ST7_LIBx is installed. For example, assuming that you have installed ST7_LIBx in D:\

a) The following paths will be updated for Metrowerks in the Default.env:

ST7LIB_PT: Change this path to installation of library

TOOL_PT: Change this path to Metrowerks toolchain path

Depending on the peripherals required for the application update the object list in *.prm and *.mak files.

b) The following paths will be updated for Cosmic in *.mak file

– Update the source path

PATHC: Change this path to cosmic toolchain installation path

LIB_PT: Change this path to library installation path

SRx_PT = \$(LIB_PT)\peripherals\periph\C

where x is the no. of source path for each peripheral

where periph is the name of the peripheral used in the application

– Update the include path

CFLAGS = +mods +debug -co \$(OBJ_PT) -i \$(SRx_PT)

where x is the no. of source path for each peripheral (give the path of all the peripherals present in the particular device)

– Update the source list

SRC_LIST = \$(OBJ_PT)\..\source\main.c \$(SRx_PT)

where x is the no. of peripheral used

5. Modify ST7lib_config.h file to include the target device, CPU frequency and the communication mode if any of the communication peripherals is used.

6. Include ST7lib_config.h in main.c

7. Write the application program using the library functions given in the user manual for each peripheral and compile.

Caution: Only the ST7lib_config.h and the files contained in the configuration subdirectory of the examples folder are user-modifiable, the rest of the source files are write protected. Changing peripheral source files and header files may adversely affect the library operations and this will be complicated to update when there are new library releases.

6.2 USING THE COMMUNICATION PERIPHERALS LIBRARY

6.2.1 SCI

This part of the user manual contains the detailed description of all the functions for the SCI. An example 'C' program has been given at the end.

You can select either of the two Transmission/Reception modes of SCI implemented inside the library. For selecting any of the possible modes described below you need to select the corresponding #define statement inside the ST7lib_Config.h file

Polling:

With this mechanism the data can be transmitted or received by polling the status of the corresponding flag. Here both the single as well as continuous Transmission/Reception is possible. In continuous Transmission/Reception, control will be inside the function until all the requested data is Transmitted/Received and hence the application software has the risk of losing control if there is a breakdown in communication (the SCI mode is disabled). To avoid this risk, you can use the single byte transmission with some time out protection inside this mechanism. This mechanism can only be used with the SCI in half duplex mode. To use this mode you must have selected the following # define labels inside the ST7lib_config.h file:

```
SCI_POLLING_TX           -- For Transmission mode
SCI_POLLING_RX           -- For Reception mode
```

For SCI2 in ST72F561 device the labels are:

```
SCI2_POLLING_TX         -- For Transmission mode
SCI2_POLLING_RX         -- For Reception mode
```

Interrupt driven without communication buffer:

With this method data can be Transmitted/Received either in single or continuous mode using interrupts. In continuous mode the user data is directly being read/written from/to the addresses passed by the user. After each byte of data transfer an interrupt is acknowledged and the control goes to the interrupt subroutine. The main advantage of using interrupts rather than polling is that control does not stay in the function till the last data is Transmitted/Received and hence the SCI can be used in full duplex mode. Here, you should take care not to read/write the user buffer until the Transmission/Reception is complete. To use this mode you must select the following # define labels in the ST7lib_config.h file:

```
SCI_ITDRV_WITHOUTBUF_TX  -- For Transmission
SCI_ITDRV_WITHOUTBUF_RX  -- For Reception
```

For SCI2 in ST72F561 device the labels are:

```
SCI2_ITDRV_WITHOUTBUF_TX -- For Transmission on SCI2
SCI2_ITDRV_WITHOUTBUF_RX -- For Reception on SCI2
```

6.2.2 SPI

SPI: This part of the user manual contains the detailed description of all the functions for the SPI. An example C program has been given at the end.

The SPI can be used as Single master (multiple slaves) and multi master systems in full duplex mode. This can be configured by using parallel port pins to control the SS pin by software. The transfer of master or slave control can be implemented using a handshake method through the I/O ports or by an exchange of code messages through the serial peripheral interface system.

In order to respect the SPI protocol, you must define the configuration setting `SPI_SLAVE_CONFIG` in `ST7lib_config.h` file as shown below, in order to be able to transmit data in software slave mode. `#define SPI_SLAVE_CONFIG` To select any of the possible communication modes described below you need to select the corresponding `#define` statement inside the `ST7lib_config.h` file. These modes are applicable for all communication peripherals (SPI, SCI and I2C).

Polling:

With this mechanism the data can be transmitted or received by polling the status of the corresponding flag. Both single and continuous Transmission/Reception is possible. In the case of continuous Transmission/Reception the function keeps control until all the requested data is Transmitted/Received and hence the application software has the risk of losing control if there is a breakdown in communication (the SCI mode is disabled). To avoid the risk, you can use the single byte transmission with some timeout protection inside this mechanism. This mechanism can only be used with the SPI in half duplex mode. To use this mode, you must have selected the following `# define` labels inside the `ST7lib_config.h` file:

```
SPI_POLLING_TX           -- For Transmission mode
SPI_POLLING_RX          -- For Reception mode
```

Interrupt driven without communication buffer:

Data can be Transmitted/Received both in single as well as continuous mode through the interrupt driven mechanism. In the continuous mode the user data is directly being read/written from/to the addresses passed by the user. After each byte of data transfer an interrupt is acknowledged and the control goes to the interrupt subroutine. The main advantage of using interrupts rather than polling is that control does not stay in the function till the last data is Transmitted/Received and hence the SPI can be used in full duplex mode. Here you should take care not to read/write the user buffer until the Transmission/Reception completion. To use this mode you must select the following `# define` labels inside the `ST7lib_config.h` file:

```
SPI_ITDRV_WITHOUTBUF_TX  -- For Transmission
SPI_ITDRV_WITHOUTBUF_RX  -- For Reception
```

Notes:

1. If both `SPI_ITDRV_WITHOUTBUF_TX` and `SPI_ITDRV_WITHOUTBUF_RX` are defined in full duplex mode, then the program will perform either transmission or reception (only transmission as per the present structure) since, the peripheral has a single interrupt for both Transmission and Reception completion. Because of this correct full duplex communication will be prevented. In order to operate the SPI in Full Duplex Mode, it is required that either the

Transmission or Reception is performed in Polling Mode and the other in Interrupt Driven Mode. So, you can use any one of the following combinations in full duplex mode.

```
SPI_POLLING_TX           -- For Transmission mode
SPI_ITDRV_WITHOUTBUF_RX -- For Reception
(or)
SPI_ITDRV_WITHOUTBUF_TX -- For Transmission
SPI_POLLING_RX          -- For Reception mode
```

6.2.3 I2C

This part of the user manual contains the detailed description of all the functions for I2C. An example C program has been given at the end. You can select either of the two Transmission/Reception modes implemented in the library. To select any of the possible modes described below, you need to select the corresponding #define statement inside the ST7lib_config.h file.

Polling:

With this mechanism the data can be transmitted or received by polling the status of the corresponding flag. Either single or continuous Transmission/Reception is possible. In continuous Transmission/Reception control stays inside the function until all the requested data is Transmitted/Received and hence the application software risks losing control if there is a breakdown in communication (if the I2C mode is disabled). To avoid the risk, the application can use single byte transmission with some timeout protection. This mechanism can only be used with the I2C in half duplex mode. To use this mode, you must have selected the following # define labels in the ST7lib_config.h file:

```
I2C_POLLING_TX           -- For Transmission mode
I2C_POLLING_RX          -- For Reception mode
```

Interrupt driven without communication buffer

Data can be Transmitted/Received both in single as well as continuous mode through the interrupt driven mechanism. In continuous mode the user data is directly read/written from/to the addresses passed by the user. After each byte of data transfer an interrupt is acknowledged and the control goes to the interrupt subroutine. The advantage of using interrupts rather than polling is that control does not stay in the function till the last data is Transmitted/Received. Here, care should be taken not to read/write the user-buffer until the Transmission/Reception completes. To use this mode, you must select the following # define labels inside the ST7lib_config.h file:

```
I2C_ITDRV_WITHOUTBUF_TX -- For Transmission
I2C_ITDRV_WITHOUTBUF_RX -- For Reception
```

Master Receiver Communication Methodology:

In Master receiver mode, to close the communication the STOP bit must be set to generate a stop condition, before reading the last byte from the DR register. In order to generate the non-acknowledge pulse after the last received data, the ACK bit must be cleared just before reading the second last byte. The following flowchart shows the management of the ACK and STOP bits, when the master is receiving.

For Example, if 'N' Bytes to be received,

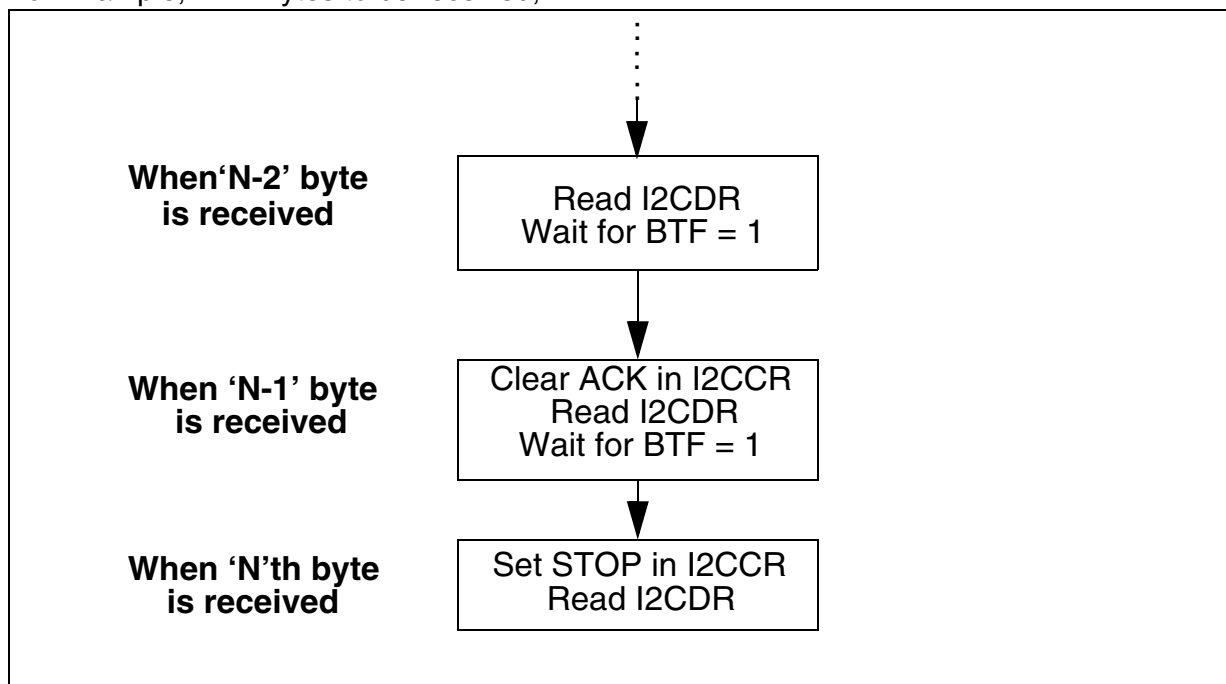

In I2C_GetBuffer, the ACK and STOP bits are automatically managed inside the function. In I2C_GetByte you must manage the ACK and STOP bits as shown below, in order to receive only one byte.

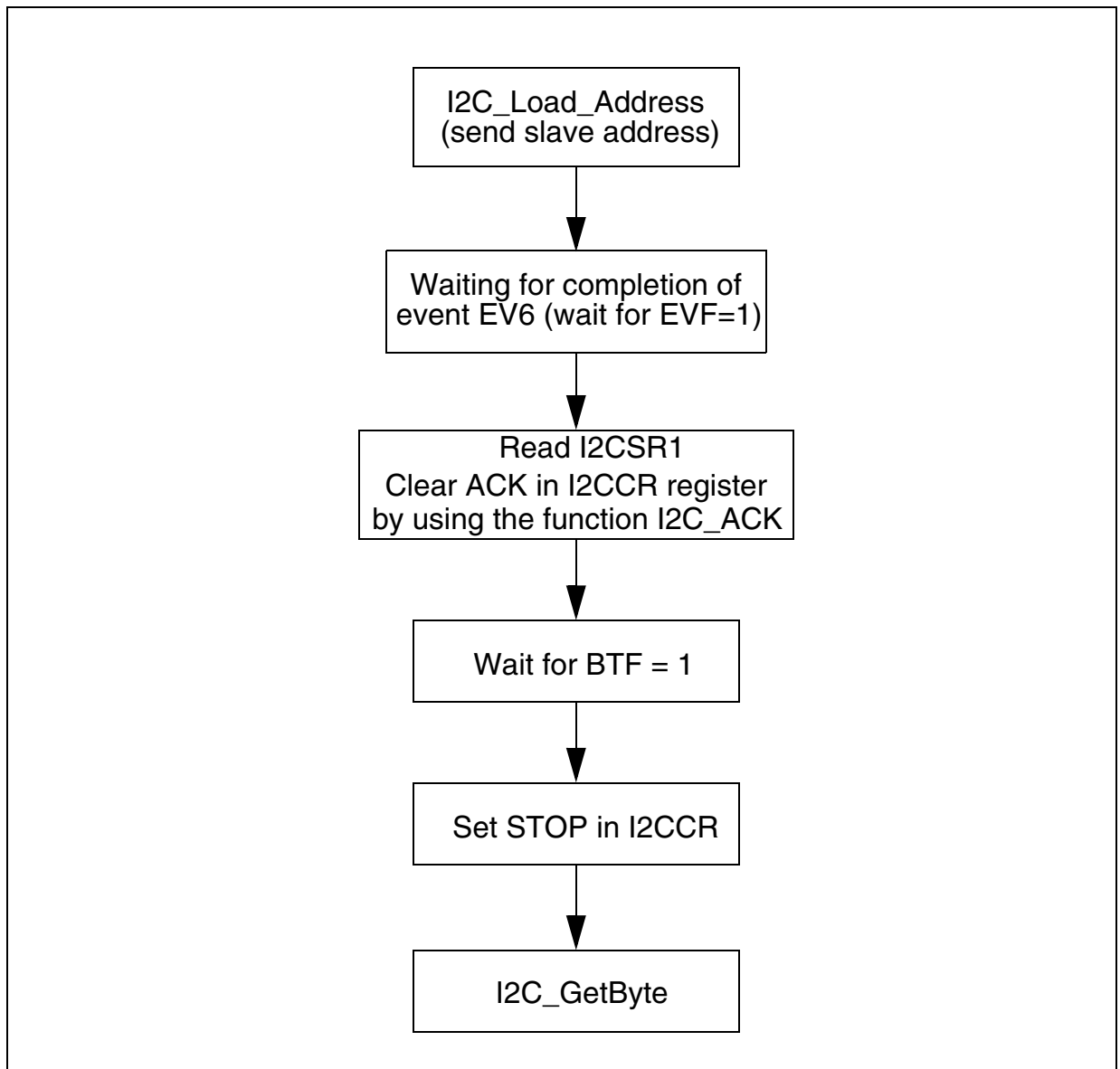
Figure 3. Flow-Chart for single byte reception in Master mode

6.2.4 CAN

This Section gives an overview of the user guidelines for the CAN Library. The library provides the software routines to use the CAN peripheral for ST72F561 device. The library is based on the HIS / Vector CAN driver specification. The implemented function list is a subset of the functions described in the HIS / Vector CAN driver specification document.

6.2.4.1 DESCRIPTION

Files

Can.c - This file contains the CAN driver source code.

Can.h - This file contains the data structure, data type definitions and function prototypes for the driver functions.

Can_hr.h - This file contains the #define statements for the driver functions.

User.c - This file contains the Global data declaration which is used by both driver as well as application. For example - Tx & Rx buffers, Tx & Rx Id, Confirmation & Indication flags etc.

User.h - This file contains all user configurable parameters. For example- size of Tx & Rx buffers, Number of Tx & Rx messages, hardware registers initialization values etc.

Note: User.c and User.h can be configured by the user depending on the application.

6.2.4.2 DATA STRUCTURES

Init Structure

Init structure contains the initialization values for the CAN controller registers. The user application may have more than one Init Structures which is configured by the parameter NO_OF_INIT_HANDLES. The init handle is used as an index for the init structure.

Transmit Structure

The transmit structure contains the information about the transmitted message, for example tx_id, tx_dlc, tx_buffer. There is a separate table each for Id, dlc, pointer to tx_buffer. The number of transmit structures depends on the number of messages to be transmitted in an application. It is configured by the parameter NO_OF_TX_HANDLES. The tx_handle is used as an index for each transmit structure. The tx_identifier has two tables: one table each for standard and extended identifiers. The tx_id, tx_dlc tables are configured by the user as per the message to be transmitted. There is a single bit confirmation flag for each transmit message.

Receive Structure

The receive structure contains the information about the received message, for example rx_id, rx_dlc, rx_buffer. There is separate table each for Id, dlc, pointer to rx_buffer. The number of receive structures depends up on number of messages to be received in an application. It is configured by the parameter NO_OF_RX_HANDLES. The rx_handle is used as an index for each receive structure. The rx_identifier has two tables: one table each for standard and extended identifiers. The identifier for the received message is stored inside this table by the driver. The rx_dlc is configured by the user as per the length of the message. There is a single bit indication flag and overflow flag for each received message.

6.2.4.3 DATA TYPES

The following are the data types used by the driver-

canuint8 8-bit unsigned integer

canuint16 16-bit unsigned integer

There are some data types referenced while calling driver function -

CanInitHandle 8-bit unsigned integer (application-specific, depends on the number of configured initialization modes).

CanTransmitHandle 8-bit unsigned integer (application-specific, depends on the number of transmit objects).

```
tCanMsgObject typedef volatile struct
{
    canuint16 stdid;
    canuint16 extid;
    canuint8 dlc;
    canuint8 data[8];
}
```

This is a transmit message structure referenced for the CAN driver service CanMsgTransmit().

6.2.4.4 MEMORY USAGE

Constants

This includes the initialization values inside the Init Structure for the CAN controller registers, transmit message information(tx_id, tx_dlc) inside the transmit structure, and receive message information(rx_dlc). These are stored in ROM.

Global Variables

These include the transmit & receive buffers, confirmation & indication flags, pointers to the Tx & Rx buffers, and receive message id's(rx_id).

6.2.4.5 PARAMETER CONFIGURATION

There are certain parameters that you have to configure depending on the application. These parameters are configured inside the files user.c & user.h.

The following are the parameters that must be configured in the file user.h -

1. NO_OF_TX_HANDLES - This parameter defines the number of messages to be transmitted by the application.
2. NO_OF_RX_HANDLES- The number of messages to be received by the application which depends on the number of messages configured in the filter registers.
3. NO_OF_INIT_HANDLES- The number of initialization structures required in an application. By default, its value is set to 1.

4. TX_MSGx_STDID - The standard id part for the MSGx to be transmitted, where x = transmit message number.
5. TX_MSGx_EXTID - The extended id part for the MSGx to be transmitted, where x = transmit message number.
6. TX_MSGx_DLC - The length for the MSGx to be transmitted, where x = transmit message number. The maximum length that can be defined is 8.
7. RX_MSGx_DLC - The length for the MSGx to be received, where x = receive message number. The maximum length that can be defined is 8.
8. REG_INITx_VALUE - The register initialization value for the CAN controller register, where REG - register name, x = init structure number.

The following are the parameters that must be configured in the file user.c -

1. MSGx_Tx_Buffer - This declares the buffer for the MSGx to be transmitted. The length of the buffer is the same as defined by the parameter TX_MSGx_DLC in the file user.h. The number of such buffers to be declared is the same as defined by the parameter NO_OF_TX_HANDLES in the file user.h.
2. tx_stdid[] - This table stores the standard id value/s for the message/s to be transmitted. The length of the table is the same as defined by the parameter NO_OF_TX_HANDLES and the value/s stored inside is/are the same as defined by the parameter TX_MSGx_STDID in the file user.h. If the message to be transmitted is Extended then above has to logical-ORed with the EXT_ID_MASK(IDE bit), EXID17 & EXID16 bit values. As a result, the values stored inside the table are in the same format as of MIDR0 & MIDR1 registers.
3. tx_extid[] - This table stores the extended id value/s for the message/s to be transmitted. The length of the table is the same as defined by the parameter NO_OF_TX_HANDLES and the value/s stored inside the table is/are the same as defined by the parameter TX_MSGx_EXTID in the file user.h. It stores the values into the same format as of MIDR2 & MIDR3 registers.
4. tx_dlc[] - This table stores the length for the message/s to be transmitted. The length of the table is the same as defined by the parameter NO_OF_TX_HANDLES and the value/s stored inside the table is/are the same as defined by the parameter TX_MSGx_DLC in the file user.h.
5. tx_data_ptr[] - This pointer table stores the address of transmit buffer/s (MSGx_Tx_buffer). The length of the table is the same as defined by the parameter NO_OF_TX_HANDLES in the file user.h.
6. MSGx_Rx_Buffer - This declares the buffer for the MSGx to be received. The length of the buffer is the same as defined by the parameter RX_MSGx_DLC in the file user.h. Number of such buffers to be declared is the same as defined by the parameter NO_OF_RX_HANDLES in the file user.h.

7. `rx_stdid` - This declares the memory for storing the standard id part of the message to be received. The length of the table is the same as defined by the parameter `NO_OF_RX_HANDLES` in the file `user.h`.

8. `rx_extid` - This declares the memory for storing the extended id part of the message to be received. The length of the table is the same as defined by the parameter `NO_OF_RX_HANDLES` in the file `user.h`.

9. `rx_dlc[]` - This table stores the length for the message/s to be received. The length of the table is the same as defined by the parameter `NO_OF_RX_HANDLES` and the value/s stored inside the table is/are the same as defined by the parameter `TX_MSGx_DLC` in the file `user.h`.

10. `rx_data_ptr[]` - This pointer table stores the address of receive buffer/s (`MSGx_Rx_Buffer`). The length of the table is the same as defined by the parameter `NO_OF_RX_HANDLES` in the file `user.h`.

6.2.4.6 Tx & Rx BUFFER USAGE

Data can be accessed through the Tx & Rx buffers using the `tx_handle` & `rx_handle` as an index. For example, data can be written into the `MSGx_Tx_Buffer` using the pointer `tx_data_ptr[x]`, where `x = tx_handle` for the message. Similarly, data can be received from `MSGx_Rx_Buffer` using the pointer `rx_data_ptr[x]`, where `x = rx_handle` for the message.

6.2.4.7 IMPLEMENTATION HINTS

- `CanSleep()` service must not be called when message transmission is in progress otherwise sleep mode is not entered and service returns `KCANFAILED`. Also `CanTransmit()` service shall not be called while the CAN driver is in sleep mode.
- Confirmation flag is set by the driver after the successful transmission of a message and flag has to be cleared by the application. Application must call `CanInterruptDisable()` and `CanInterruptRestore()` services when clearing the confirmation flag in order to avoid CAN interrupt.
- Indication flag is set by the driver for a message received and this flag has to be cleared by the application. Application must call `CanInterruptDisable()` and `CanInterruptRestore()` services when clearing the indication flag in order to avoid CAN interrupt.
- Overflow flag is set by the driver if the indication flag is not cleared by the application or message is not copied by the application from the global buffer into the application buffer.

If the overflow is set it means that the new message has been overwritten over the previous message. Overflow flag has to be cleared by the application. Application must call `CanInterruptDisable()` and `CanInterruptRestore()` services when clearing the overflow flag in order to avoid CAN interrupt.

- While copying data from receive buffer, application must call `CanInterruptDisable()` and `CanInterruptRestore()` services in order to avoid a CAN interrupt. Similarly, while copying

data into the transmit buffer, application must call `CanInterruptDisable()` and `CanInterruptRestore()` services to avoid an interrupt.

6.3 OTHER PERIPHERALS

6.3.1 TIMER

TIMERA and TIMERB can both be used simultaneously, depending on the TIMER selected. You have to define `USE_TIMERA` and/or `USE_TIMERB` in `ST7lib_config.h`. Each function name in the user manual contains `TIMERx` where `x` can be `A` or `B` depending on whether it is for TIMERA or TIMERB. This is also explained in the example given at the end of the TIMER library.

6.3.2 I/O

You must select the following parameters as per the device package.

`#define IO_521_80PIN` - Select this for an 80-pin package for ST72F521 device in `ST7lib_config.h` file.

`#define IO_62_42PIN` - Select this for a 42-pin package for ST72F62 device in `ST7lib_config.h` file.

`#define IO_62_32PIN` - Select this for a 32-pin package for ST72F62 device in `ST7lib_config.h` file.

If you are using other device packages, you must comment out these declarations in `ST7lib_config.h` file.

6.4 MEMORY MODELS

Limitation: in Cosmic, you are not allowed to use the same function in both the main program and interrupt subroutine. This will give the error of Reentrant function in all memory models except `mods` and `modsl`.

6.5 PORTING APPLICATIONS FROM LIBRARY VERSION 1.0

Applications can be ported easily from ST7 Library Version 1.0 to ST7 Library Version 2.0 by making the following changes:

- Change the configuration files `st7lib_config.h`, `default.env`, `.mak`, `.prm`, and `.lkf`
- Add `device_reg.o` in compile list and link list in `.mak`, `.prm` and `.lkf` files
- Remove inclusion of `periph_hr.h` files from main to access device registers directly
- Replace use of `TIMERA`, `TIMERB` macros with `USE_TIMERA`, `USE_TIMERB`
- Replace `ITC_EXT_ITSensitivity` with `ITC_ConfigureInterrupt`
- Refer to the Release Notes for the list of changes in new version

7 PRESENTATION OF LIBRARY FUNCTIONS

7.1 LIBRARY REFERENCES

Functions are described in the format given below:

Function name	Peripheral name and main functionality covered
Function prototype	Prototype declaration
Behaviour Description	Brief explanation of how the functions are executed
Input Parameters	Description of the parameters to be passed
Output Parameters	Value returned by the function
Required preconditions	Specific requirements to run the function
Functions called	Library Functions called
Post conditions	Function required to call immediately after this function
See also	Related functions for user reference
Note	Important points that you must take into consideration
Caution	Important points to be considered to avoid any failures
Code example	Example to show the proper way to use the library functions

8 RELEASE INFORMATION

This release supports the following peripherals and devices.

8.1 PERIPHERALS

- ADC (8-bit and 10bit): The on-chip Analog to Digital Converter (ADC) peripheral is a 10-bit, successive approximation converter with internal sample and hold circuitry.
- SCI (with/without extended Baud Rate Pre scalar): The Serial Communications Interface (SCI) offers a flexible means of full-duplex data exchange with external equipment requiring an industry standard NRZ asynchronous serial data format.
- SPI: The Serial Peripheral Interface (SPI) allows full duplex, synchronous, serial communication with external devices.
- I2C single/multi master: The Inter-Integrated Circuit Bus Interface serves as an interface between the microcontroller and the serial I2C bus.
- I2C Slave
- 16-bit Timer: The timer consists of a 16-bit free-running counter driven by a programmable prescaler.
- 8-bit Timer: The timer consists of a 8-bit free-running counter driven by a programmable prescaler.
- 8-bit Lite timer: The Lite Timer can be used for general-purpose timing functions.
- PWM ART 8-bit: The Pulse Width Modulated Auto-Reload Timer on-chip peripheral consists of an 8-bit auto reload counter with compare/capture capabilities and of a 7-bit prescaler clock source.
- AR 12-bit timer: The 12-bit Autoreload Timer can be used for general-purpose timing functions.
- TBU: The Timebase unit (TBU) can be used to generate periodic interrupts.
- WDG: The Watchdog timer is used to detect the occurrence of a software fault.
- ITC: The Interrupt Controller manages the hardware and software interrupts with flexible interrupt priority and level configuration.
- MCC: The Main Clock Controller consists of a programmable CPU clock prescaler, a clock-out signal to supply external devices and a real time clock timer with interrupt capability.
- EEPROM: The Electrically Erasable Programmable Read Only Memory can be used as a non volatile backup for storing data.
- I/Os: An I/O port contains up to 8 pins. Each pin can be programmed independently as digital input (with or without interrupt generation) or digital output.
- CAN: The Controller area Network peripheral allows communication over a CAN network.

8.2 DEVICES

- ST72F62
- ST72F63B
- ST72F65
- ST72F521
- ST7FLITE0
- ST7FLITE1
- ST7FLITE2
- ST7FLITE3
- ST72F264
- ST72F561
- ST7SUPERLITE
- ST72325
- ST7232A

9 FUNCTION DESCRIPTIONS

9.1 GENERAL PURPOSE PERIPHERALS

9.1.1 ADC

This software library consists of the following functions for 8-bit and 10-bit ADC.

Function Name	ADC_Init
Function Prototype	Void ADC_Init (Typ_ADC_InitParameter InitValue)
Behaviour Description	Initialization of the ADC, sets by default, channel to AIN0, speed to default value of the device, ADC off, amplifier off, interrupt disable and Continuous conversion mode. You can pass one or more input parameters by logically ORing them together to change the default configuration.
Input Parameters	<p>ADC_SPEED ¹⁾ Fadc=Fcpu/4 or Fcpu/2 or Fcpu, depending upon the device selected.</p> <p>ADC_SLOW ²⁾ It is used together with ADC_SPEED to configure ADC clock for device.</p> <p>ADC_ONESHOT ³⁾ One shot conversion active</p> <p>ADC_AMPLIFIER_ON ⁴⁾ Amplifier on</p> <p>ADC_DEFAULT sets ADC in default configuration.</p> <p>ADC_IT_ENABLE ³⁾ Interrupt enable for end of conversion.</p>
Output Parameters	None
Required Preconditions	<ol style="list-style-type: none"> 1. Configure IO properly. 2. Selection of the right ADC in the file ST7lib_config.h
Functions called	None
Postconditions	ADC correctly configured
See also	ADC_Enable and ADC_Select_Channel

1)Speed bit is present in ST72F561, ST72F62, ST72F264, ST72F521, ST72325, ST7232A, ST7DALI, ST7FLITE0/1/2/3 and ST7SUPERLITE.

2)Slow bit is present in ST72F561, ST72F264, ST7DALI, ST7FLITE0/1/2/3 and ST7SUPERLITE.

3)Feature present only in ST72F62.

4)Amplifier present in ST7DALI, ST7FLITE0/1/2 and ST7SUPERLITE.

Table 2. ADC_Select_Channel

Function Name	ADC_Select_Channel
Function Prototype	Void ADC_Select_Channel (unsigned char ADC_AIN)
Behaviour Description	Selects the conversion channel by passing the channel number as input parameter
Input Parameters	ADC_AIN ADC_AIN is in the range [0:15] The channel number depends on the device, please refer to the corresponding datasheet.
Output Parameters	None
Required Preconditions	1. 'ADC_Init' must have been called. 2. The selected channel must be configured as floating input.
Functions called	None
Postconditions	ADC channel selected
See also	ADC_Enable

Table 3. ADC_Enable

Function Name	ADC_Enable
Function Prototype	Void ADC_Enable (void)
Behaviour Description	Switches on the ADC to start conversion on the selected channel.
Input Parameters	None
Output Parameters	None
Required Preconditions	ADC_Select_Channel must have been called.
Functions called	None
Postconditions	ADC conversion started
See also	ADC_Disable

Table 4. ADC_Test_Conversn_Complete

Function Name	ADC_Test_Conversn_Complete
Function Prototype	BOOL ADC_Test_Conversn_Complete (void)
Behaviour Description	Returns the latest status of conversion
Input Parameters	None
Output Parameters	TRUE : conversion completed FALSE : conversion not completed
Required Preconditions	ADC_Enable must have been called.
Functions called	None
Postconditions	If TRUE, ADC conversion is complete and you can call the ADC_Conversn_Read. If FALSE, ADC conversion not completed. This function can be looped until the conversion is complete.
See also	ADC_Disable, ADC_Conversn_Read

Table 5. ADC_Conversn_Read

Function Name	ADC_Conversn_Read
Function Prototype	For 10-bit ADC, unsigned int ADC_Conversn_Read (void) For 8-bit ADC, unsigned char ADC_Conversn_Read (void)
Behaviour Description	Reads the converted digital value from the data register.
Input Parameters	None
Output Parameters	Data Register value (it depends upon the device selected, please refer to the corresponding data sheet).
Required Preconditions	ADC_Test_Conversn_Complete must have been called.
Functions called	None
Postconditions	1. EOC flag is cleared. 2. Equivalent digital value available in the data register is returned.
See also	None

Note: The EOC flag may be set again during the execution of this function, this depends on the conversion time.

Table 6. ADC_Disable

Function Name	ADC_Disable
Function Prototype	Void ADC_Disable (void)
Behaviour Description	Stops ADC conversion on the selected channel.
Input Parameters	None
Output Parameters	None
Required Preconditions	ADC is switched on
Functions called	None
Postconditions	ADC switched off
See also	ADC_Enable

Example:

The following C program shows the use of the ADC functions.

Program description:

This program converts the analog value on channel 5 of the ST72F62 device to a digital value.

```

/* Program start */
#include "st7lib_config.h"                                /* Select st72F62 device */
void main (void);

void main(void)
{
    unsigned int Conv_Data1;                               /* Variable to get the converted digital value */
    unsigned char channel = 5;

    ADC_Init ((unsigned char )ADC_SPEED | (unsigned char )ADC_ONESHOT); /* FADC= FCPU/4 */
    ADC_Select_Channel (channel);                          /* Channel 5 selected */
    ADC_Enable ();                                        /* Start conversion */
    while (ADC_Test_Conversn_Complete () == FALSE);
    Conv_Data1 = ADC_Conversn_Read ();                    /* Read the converted value */
    ADC_Disable ();
    Nop;                                                  /* Macro defined in st7lib_config.h */
}
/* Program end */

```

9.1.2 SCI

This Library supports 2 SCI of ST72F561 device and 1 SCI on all other devices.

For devices with only one SCI no suffix “x” is used in the function names.

For 2nd SCI of ST72F561 you must replace suffix “x” in the function names with 2.

Function Name	SCIx_Init
Function Prototype	Void SCIx_Init (SCI_Type_Param1 Init_Value1, SCI_Type_Param2 Init_Value2)
Behaviour Description	Initialization of SCI, sets by default receiver sleep off, no break character will be transmitted, wakeup from sleep by idle frame detection, Parity disabled, 8-bit transmission mode and Receiver in active mode. You can select the parity, 9-bit transmission mode, Receiver wakeup, Receiver Mute and Break Enable feature through properly selecting the Init_Value1 and Init_Value2.
Input Parameter 1	<p>SCI_ODPARITY_SELECT Select odd Parity</p> <p>SCI_EVPARITY_SELECT Select even parity</p> <p>SCI_WAKEUP_ADDR Receiver wake up from mute mode while address mark is detected(i.e MSBit of the data transmitted should be 1)</p> <p>SCI_WORDLENGTH_9 Select 9-bit transmission</p> <p>SCI_DEFAULT_PARAM1 Load the register with the default value(0x00)</p>
Input Parameter 2	<p>SCI_MUTE_ENABLE Receiver in mute mode</p> <p>SCI_BREAK_ENABLE Transmit break characters</p> <p>SCI_DEFAULT_PARAM2 Load the register with the default value(0x00)</p>
Output Parameter	None
Required Preconditions	SCI port pin should be configured properly.

Table 7. SC1x_Compute_Baudrate

Function Name	SC1x_Compute_Baudrate
Function Prototype	Void SC1x_Compute_Baudrate(unsigned int BaudRate_Tx, unsigned int BaudRate_Rx)
Behaviour Description	Selects Transmitter/ Receiver baudrate for the SCI without extended prescaler.
Input Parameter 1	BaudRate_Tx* You can select any possible baudrate for transmission.
Input Parameter 2	BaudRate_Rx* You can select any possible baudrate for reception.
Output Parameter	None
Required Preconditions	1. SC1x_Init, must have been called. 2. fcpu must have been defined in ST7lib_Config.h
Functions called	None
Postconditions	None

Note:

- This function takes a large ROM area as calculations for TR, RR and PR are done inside the function. However, you can choose to pass the baudrate directly.
- If the selected baudrate speed is not possible, the closest possible value will be used.
- If there is no common prescalar factor for receiver and transmitter baudrates, then you will get the nearest possible receiver baudrate, at the prescalar division factor selected for the transmitter.
- In half Duplex mode you can pass the same transmitter and receiver baudrates to get the exact Tx/Rx baudrate (whichever mode you are using)

Table 8. SCIx_Select_Baudrate

Function Name	SCIx_Select_Baudrate
Function Prototype	Void SCIx_Select_Baudrate (SCI_Baudrate_Type Baudrate_Prescaler)
Behaviour Description	Selects Transmit/Receive baudrate for SCI without extended baudrate prescaler. You have to define all the prescaler parameters corresponding to the desired baudrate speed. You have to pass the three input parameters by logically ORing them to select the baudrate.
Input Parameters	SCI_PR_X X=1,3, 4,13 SCI_TR_Y Y=1,2,4,8,16,32,64,128 SCI_RR_Z Z=1,2,4,8,16,32,64,128
Output Parameter	None
Required Preconditions	1. SCIx_Init must have been called 2. You have to specify the PR, RR and TR values for the desired baudrate
Functions called	None
Postconditions	Refer to the table below.

SCI_PR_X	SCI_TR_Y	SCI_RR_Z	Transmitter baudrate speed	Receiver baudrate Speed
SCI_PR_13	SCI_TR_1	SCI_RR_1	38400	38400
SCI_PR_13	SCI_TR_2	SCI_RR_2	19200	19200
SCI_PR_13	SCI_TR_4	SCI_RR_4	9600	9600
SCI_PR_13	SCI_TR_8	SCI_RR_8	4800	4800
SCI_PR_13	SCI_TR_16	SCI_RR_16	2400	2400
SCI_PR_13	SCI_TR_32	SCI_RR_32	1200	1200

Note: This function saves the ROM area but you have to pass the values for the TR,PR RR.

Table 9. SCIx_Extend_Baudrate

Function Name	SCIx_Extend_Baudrate
Function Prototype	Void SCIx_Extend_Baudrate (SCI_Baudrate_Type Baudrate_Prescaler, unsigned char EPTR, unsigned char EPRR)
Behaviour Description	Selects Transmit/Receive baudrate for SCI with extended baudrate prescaler. You have to define all the prescaler parameters corresponding to the desired baudrate speed.
Input Parameter 1	SCI_PR_X X=1,3, 4,13 SCI_TR_Y Y=1,2,4,8,16,32,64,128 SCI_RR_Z Z=1,2,4,8,16,32,64,128
Input Parameter 2	EPTR Select any value from 0 to 255
Input Parameter 3	EPRR Select any value of EPRR from 0 to 255
Output Parameter	None
Required Preconditions	1.SCIx_Init must have been called 2. You have to specify the PR, RR and TR values for the desired baudrate
Functions called	None
Postconditions	Refer to the table below.

SCI_PR_X	TR_Y	RR_Z	EPTR	EPRR	Transmitter baudrate speed	Receiver baudrate Speed
SCI_PR_13	SCI_T R_1	SCI_RR _1	1	1	38400	38400
SCI_PR_13	SCI_T R_2	SCI_RR _2	2	2	9600	9600
SCI_PR_13	SCI_T R_4	SCI_RR _4	3	3	3200	3200
SCI_PR_13	SCI_T R_8	SCI_RR _8	4	4	1200	1200
SCI_PR_13	SCI_T R_16	SCI_RR _16	5	5	480	480
SCI_PR_13	SCI_T R_32	SCI_RR _32	6	6	200	200

Table 10. SCIx_IT_Enable

Function Name	SCIx_IT_Enable
Function Prototype	Void SCIx_IT_Enable (SCI_IT_Type SCI_IT_Param)
Behaviour Description	Selects SCI interrupts
Input Parameters	<p>SCI_IDLE_LINE Enable interrupt due to idle frame reception.</p> <p>SCI_RECEIVE_OVERRUN Enable interrupt due to data reception or overrun error.</p> <p>SCI_TRANSMIT_REGISTER_READY Enable interrupt when transmit data register is ready to load.</p> <p>SCI_FRAME_TRANSMITTED Enable Interrupt due to Transmission completion.</p> <p>SCI_PARITY_ERROR Enable Interrupt due to Parity Error.</p>
Output Parameter	None
Required Preconditions	<ol style="list-style-type: none"> 1. SCIx_ComputeBaudrate or SCIx_SelectBaudrate must have been called. 2. You should reset the interrupt mask with EnableInterrupts.
Functions called	None
Postconditions	None
See also	None

Table 11. SC1x_IT_Disable

Function Name	SC1x_IT_Disable
Function Prototype	Void SC1x_IT_Disable (SCI_IT_Type SCI_IT_Param)
Behaviour Description	Disables SCI interrupts
Input Parameters	<p>SCI_IDLE_LINE Disable interrupt due to idle frame reception.</p> <p>SCI_RECEIVE_OVERRUN Disable interrupt due to data reception or overrun error.</p> <p>SCI_TRANSMIT_REGISTER_READY Disable interrupts triggered when transmit data register is ready to load.</p> <p>SCI_FRAME_TRANSMITTED Disable Interrupt due to Transmission completion.</p> <p>SCI_PARITY_ERROR Disable Interrupt due to Parity Error.</p>
Output Parameters	None
Required Preconditions.	The baudrate must have been selected
Functions called	None
Postconditions	None
See also	None

Table 12. SC1x_Mode

Function Name	SC1x_Mode
Function Prototype	Void SC1x_Mode (SCI_Mode_Type SCI_Mode_Param)
Behaviour Description	Enables Transmitter/Receiver mode of SCI.
Input Parameter	<p>SCI_TX_ENABLE Enable the Transmitter mode.</p> <p>SCI_RX_ENABLE Enable the Receiver mode.</p>
Output Parameter	None
Required Preconditions	SC1x_IT_Enable must have been called for interrupt mode
Functions called	None
Postconditions	None
See also	None

Note: To disable the SCI Mode, select the SC1x_Init function.

Table 13. SC1x_PutByte

Function Name	SC1x_PutByte
Function Prototype	Void SC1x_PutByte (unsigned char Tx_Data)
Behaviour Description	Transmits a single byte of data polling mode or interrupt driven mode.
Input Parameters	Tx_Data Data byte to be transmit.
Output Parameters	None
Required Preconditions	<ol style="list-style-type: none"> 1. SC1x_Mode must have been called. 2. SC1x_IsTransmitCompleted must have been called (Refer to example on page 53 for more details). 3. You must enable the interrupt due to Transmit Complete/Transmit Data Ready Flag for the Interrupt driven mode 4. You must select Polling or Interrupt driven Transmission mode in ST7lib_config.h
Functions called	None
Postconditions	None
See also	None

Notes:

- You can use some timeout protection while using this function.
- This function is for **Polling** or **Interrupt driven** mode.

Table 14. SC1x_IsTransmitCompleted

Function Name	SC1x_IsTransmitCompleted
Function Prototype	BOOL SC1x_IsTransmitCompleted (void)
Behaviour Description	Checks for the completion of current byte transmission. Returns TRUE if byte transmission is completed otherwise returns FALSE.
Input Parameters	None
Output Parameters	Boolean
Required Preconditions	SC1x_PutByte must have been called.
Functions called	None
Postconditions	None
See also	None

Note: This function is for **Polling** mode.

Table 15. SCIx_PutBuffer

Function Name	SCIx_PutBuffer
Function Prototype	Void SCIx_PutBuffer(const unsigned char *PtrToBuffer, unsigned char NbOfBytes)
Behaviour Description	Starts transmission from the user buffer. The data transmission will be driven either in Polling or Interrupt driven mode depending on the mode you selected.
Input Parameter 1	*PtrToBuffer Start address of the user buffer
Input Parameter 2	NbOfBytes Number of bytes to be transmitted
Output Parameter	None
Required Preconditions	<ol style="list-style-type: none"> 1. SCIx_Mode must have been called. 2. You must enable the interrupt due to Transmit Data Ready Flag for the Interrupt driven mode 3. You must select the Polling or Interrupt driven transmission mode in ST7lib_Config.h file. 4. The SCIx_IT_Function must have been called inside the SCI interrupt subroutine.
Functions called	SCIx_IsTransmitCompleted
Postconditions	None
See also	None

Note: This function is for **Polling** or **Interrupt driven** mode.

Caution:

- The application can lose control if the SCI is disabled while using this function in polling mode.
- Take care not to access the user buffer until transmission is complete.

Table 16. SCIx_PutString

Function Name	SCIx_PutString
Function Prototype	Void SCIx_PutString (const unsigned char *PtrToString)
Behaviour Description	Starts transmission of a string passed by the user. The data transmission will be through polling or interrupt driven modes depending on the mode you selected.
Input Parameters	*PtrToString Start address of the user string
Output Parameters	None
Required Preconditions	<ol style="list-style-type: none"> 1. SCIx_Mode must have been called. 2. You must enable the interrupt due to Transmit Data Ready Flag for Interrupt driven mode. 3. You must select the transmission mode Polling or Interrupt driven in ST7lib_Config.h. 4. SCIx_IT_Function must have been called inside the SCI interrupt subroutine.
Functions called	SCIx_IsTransmitCompleted
Postconditions	None
See also	None

Note: This function is for **Polling** or **Interrupt driven** mode.

Caution:

- The application can lose control if the SCI is disabled while using this function in polling mode.
- Take care not to access the string until transmission is complete.

Table 17. SCIx_IsTransmitCompleted

Function Name	SCIx_IsTransmitCompleted
Function Prototype	BOOL SCIx_IsTransmitCompleted (void)
Behaviour Description	Checks for the completion of data transmission. It returns FALSE till all the data bytes have been transmitted and TRUE when the request is over.
Input Parameters	None
Output Parameters	Boolean
Required Preconditions	Transmission must have been requested.
Functions called	None
Postconditions	SCIx_PutByte/SCIx_PutBuffer/SCIx_PutString must be called after this function
See also	None

Note: This function is for **Interrupt driven** mode.

Table 18. SC1x_9thBit_TxRx

Function Name	SC1x_9thBit_TxRx
Function Prototype	BOOL SC1x_9thBit_TxRx (BOOL Bit9_Val)
Behaviour Description	This function configures the 9th bit to be transmitted as 0 or 1 for 9-bit transmission. Also it returns the status of the 9th bit in the 9-bit reception mode.
Input Parameters	TRUE If 1 is to be transmitted as 9th bit. FALSE If 0 is to be transmitted as 9th bit.
Output Parameters	TRUE If 9th bit received is 1. FALSE If 9th bit received is 0.
Required Preconditions	1.SCI must be configured in 9 bit mode. 2.For reception function SC1x_GetString/SC1x_GetBuffer/SC1x_GetByte must have been called before this function.
Functions called	None
Postconditions	For transmission SC1x_PutByte/SC1x_PutBuffer/SC1x_PutString must be called after this function.
See also	None

Notes:

- In transmission, the return value of the function is ignored. In reception, the input parameter is not significant.
- You must call this function while using 9 bit mode.
- The Status of the 9th bit remains same during the complete buffer/string transmission.
- You can change the status of 9th bit in the next request.

Table 19. SC1x_GetByte

Function Name	SC1x_GetByte
Function Prototype	Unsigned char SC1x_GetByte (void)
Behaviour Description	Returns the most recent Byte received in <i>Polling</i> or <i>Interrupt driven</i> mode.
Input Parameters	None
Output Parameters	Unsigned char Received data byte
Required Preconditions	<ol style="list-style-type: none"> 1. The SC1x_Mode must have been called 2. You must have called SC1x_IsReceptionCompleted to check the reception status. 3. You must enable the interrupt due to Receive Data Ready flag for <i>Interrupt driven</i> mode. 4. You must select <i>Polling</i> or <i>Interrupt driven</i> Reception mode in ST7lib_Config.h. 5. For <i>Interrupt driven</i> mode SC1x_IT_Function must have been called inside the SCI interrupt subroutine.
Functions called	None
Postconditions	None
See also	None

Notes:

- You can use some timeout protection while using this function.
- This function can be used in ***Polling*** or ***Interrupt driven*** mode.

Table 20. SCIx_GetBuffer

Function Name	SCIx_GetBuffer
Function Prototype	SCI_RxError_t SCIx_GetBuffer (unsigned char *PtrToBuffer, unsigned char NbOfBytes)
Behaviour Description	Receives a number of data bytes and stores them in the user buffer. The reception stops as soon as an error occurs and error status is returned. The data reception is controlled by <i>polling</i> .
Input Parameter 1	*PtrtoBuffer Start address of the user buffer
Input Parameter 2	NbOfBytes Total number of bytes to be received
Output Parameters	SCI_NOISE_ERR Noise error occurred during transmission. SCI_OVERRUN_ERR Overrun error occurred during reception SCI_FRAMING_ERR Framing error occurred during reception SCI_PARITY_ERR Parity error occurred during reception SCI_RECEIVE_OK Error free reception
Required Preconditions	1.The SCIx_Mode must have been called. 2.You must select <i>Polling</i> reception mode in ST7lib_Config.h
Functions called	None
See also	SCIx_GetBuffer (<i>Interrupt driven</i> mode)

Note: This function is only for *Polling* mode

Caution: The application can lose control if the SCI is disabled while using this function in polling mode.

Table 21. SCIx_GetString

Function Name	SCIx_GetString
Function Prototype	SCI_RxError_t SCIx_GetString (unsigned char *PtrToString)
Behaviour Description	Receives and stores the data in the user-defined string. The reception stops as soon as an error occurs and error status is returned. The data reception is controlled by polling .
Input Parameters	*PtrToString Start address of the String
Output Parameters	SCI_NOISE_ERR Noise error occurred during reception. SCI_OVERRUN_ERR Overrun error has occurred during reception SCI_FRAMING_ERR Framing error occurred during reception SCI_RECEIVE_OK Error free reception SCI_PARITY_ERR Parity error occurred during reception
Required Preconditions	1. SCIx_Mode must have been called 2. You must select Polling reception mode in ST7lib_Config.h
Functions called	None
Postconditions	None
See also	SCIx_GetString (Interrupt driven mode)

Note: This function is only for **Polling** mode

Caution: The application can lose control if the SCI is disabled while using this function in polling mode.

Table 22. SC1x_GetBuffer

Function Name	SC1x_GetBuffer
Function Prototype	Void SC1x_GetBuffer (unsigned char *PtrToBuffer, unsigned char NbOfBytes)
Behaviour Description	Starts reception of the bytes and stores it into the user-buffer in interrupt driven mode.
Input Parameter 1	*PtrToBuffer Start address of the user buffer
Input Parameter 2	NbOfBytes Total number of bytes to be received
Output Parameters	None
Required Preconditions	<ol style="list-style-type: none"> 1. The SC1x_Mode must have been called 2. You must enable the interrupt due to Receive Data Ready flag. 3. You must select the Interrupt driven reception mode in ST7lib_Config.h 4. SC1x_IT_Function must have been called inside the SCI interrupt subroutine.
Functions called	None
Postconditions	You must call SC1x_IsReceptionCompleted after this function to check the reception status.
See also	SC1x_GetBuffer (Polling mode)

Note: This function is only for **Interrupt driven** mode.

Caution:

- Take care not to access the user buffer until reception is completed.
- Any data received before calling this function is ignored
- The data reception will stop as soon as an error occurs.

Table 23. SC1x_GetString

Function Name	SC1x_GetString
Function Prototype	Void SC1x_GetString (unsigned char *PtrToString)
Behaviour Description	Reception of data string starts through <i>interrupt driven</i> mode
Input Parameters	*PtrToString Start address of the location where string is to be placed.
Output Parameters	None
Required Preconditions	<ol style="list-style-type: none"> 1. SC1x_Mode must have been called 2. You must enable the interrupt due to Receive Data Ready flag. 3. You must select the <i>Interrupt driven</i> reception mode in ST7lib_Config.h. 4. SC1x_IT_Function must have been called inside the SCI interrupt subroutine.
Functions called	None
Postconditions	You must call SC1x_IsReceptionCompleted after this function to check the reception status.
See also	SC1x_GetString (<i>Polling</i> mode)

Note: This function is only for ***Interrupt driven*** mode.

Caution:

- Take care not to access the user buffer until reception is completed
- Any data received before calling this function is ignored
- The data reception will stop as soon as an error occurs.

Table 24. SCIx_IsReceptionCompleted

Function Name	SCIx_IsReceptionCompleted
Function Prototype	SCI_RxError_t SCIx_IsReceptionCompleted(void)
Behaviour Description	<p>In Interrupt driven mode, this function checks for the completion of reception of a set of data or the occurrence of an error and returns the reception status.</p> <p>In both Polling and Interrupt driven modes, the function checks if a single byte of data is received and ready for processing. It returns SCI_RX_DATA_EMPTY until the data byte is received and returns the reception status afterwards.</p>
Input Parameter	None
Output Parameters	<p>SCI_BUFFER_ONGOING ¹⁾ User buffer is not full</p> <p>SCI_STRING_ONGOING ¹⁾ Complete string is not received in the user buffer</p> <p>SCI_NOISE_ERR Noise error occurred during reception.</p> <p>SCI_OVERRUN_ERR Overrun error occurred during reception</p> <p>SCI_FRAMING_ERR Framing error occurred during reception</p> <p>SCI_RECEIVE_OK Error free data is stored in the user buffer</p> <p>SCI_PARITY_ERR Parity error occurred during reception</p> <p>SCI_RX_DATA_EMPTY ²⁾ No data byte is received.</p>
Required Preconditions	None
Functions called	None
Postconditions	For single byte reception, if the byte is received, then SCIx_GetByte can be called after this function.

1) These Parameters are returned in **Interrupt driven** mode only.

2) This Parameter is returned in case of single byte reception only, for both **Polling** and **Interrupt driven** modes.

Notes:

– If this function is called before any reception request is made, it will check for single byte reception, and will return SCI_RX_DATA_EMPTY until the data byte is received, and returns the reception status afterwards.

- If a reception request for a set of data is over, this function will return the error status of that request only once. If this function is called again (before making next reception request), then the function will check for single byte reception.
- In **Polling** mode, this function is used in conjunction with SC1x_GetByte only.

Table 25. SC1x_Forced_Clear_Flag

Function Name	SC1x_Forced_Clear_Flag
Function Prototype	Void SC1x_Forced_Clear_Flag(void)
Behaviour Description	Clears all the status and Error flags (TC, TDRE, RDRF, IDLE, OR, NF, FE, PE) in SCI Status register(SCISR).
Input Parameters	None
Output Parameters	None
Required Preconditions.	Transmission or Reception must have taken place.
Functions called	None
Postconditions	None
See also	None

Note: You can call this function whenever you want to force the error and status flags be cleared.

Caution: Do not call this function if a reception request is ongoing as it will corrupt the reception status by clearing all the flags and you will not receive any error status.

Table 26. SC1x_IT_Function

Function Name	SC1x_IT_Function
Function Prototype	Void SC1x_IT_Function (void)
Behaviour Description	Transmits or receives data in Interrupt driven mode. You must call this function inside the interrupt service routine.
Input Parameters	None
Output Parameters	None
Required Preconditions.	You must have called transmission or reception function in Interrupt driven mode.
Functions called	None
Postconditions	Communication is started inside the interrupt subroutine.
See also	None

Note: Only use this function in the Interrupt service routine.

Caution: Special care must be taken, while you write your own code along with this function in the interrupt service routine, otherwise, data transfer synchronisation could be affected, which may lead to data corruption.

Table 27. SCI2_Clkout_Enable

Function Name	SCI2_Clkout_Enable
Function Prototype	Void SCI2_Clkout_Enable (void)
Behaviour Description	This function enables the ClockOutput of SCI2 of ST72F561 device.
Input Parameters	None
Output Parameters	None
Required Preconditions.	None
Functions called	None
Postconditions	SCI clock is available at a dedicated pin during communication.
See also	None

Table 28. SCI2_ClkConfigure

Function Name	SCI2_ClkConfigure
Function Prototype	Void SCI2_ClkConfigure(SCI_PO_PH_t SCI_PO_PH_Param, SCI_LBCL_t SCI_LBCL_Param)
Behaviour Description	Configures the Polarity, Phase and numbers of Clock pulses for the SCI2 Clock out.
Input Parameter 1	<p>SCI_PO_LOW_PH_LOW Default value on CLK pin low CLK activated at the in the middle of data bit</p> <p>SCI_PO_LOW_PH_HIGH Default value on CLK pin low CLK activated at the beginning of data bit</p> <p>SCI_PO_HIGH_PH_LOW Default value on CLK pin High CLK activated in the middle of data bit</p> <p>SCI_PO_HIGH_PH_HIGH Default value on CLK pin high CLK activated at the beginning of data bit</p>
Input Parameter 2	<p>SCI_LBCL_DISABLE The CLK pulse of last data bit is not output to the pin</p> <p>SCI_LBCL_ENABLE The CLK pulse of last data bit is output to the pin</p>
Output Parameters	None
Required Preconditions.	None
Functions called	None
Postconditions	SCI clock is available at a dedicated pin during communication.
See also	None

EXAMPLE:

The following C program shows how the SCI functions are used.

This program runs the following sequence for an SCI without extended baudrate prescaler for polling or interrupt driven mode:

- transmits a single byte passed by the user
- transmits the 20 bytes of data at the baudrate 9600
- receives 20 bytes of data at a baud rate of 9600.

Note: You must define the communication mode and cpu speed (Fcpu) in the ST7lib_config.h file.

You can select any of the communication speeds from the following list :

SCI_POLLING_TX	-- For Transmission mode
SCI_POLLING_RX	-- For Reception mode
SCI_ITDRV_WITHOUTBUF_TX	-- For Transmission
SCI_ITDRV_WITHOUTBUF_RX	-- For Reception

/* You can use a timeout function to handle the fault in which the control will get stuck in side a loop.This function should have the Boolean return, i.e it should return TRUE if the expected wait Time is not elapsed and FALSE if it is elapsed.*/

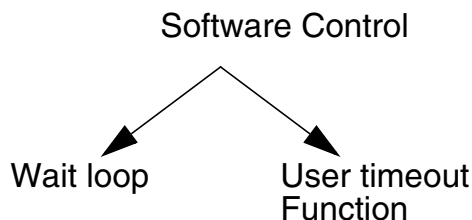

/*=====*/

The following variables are declared in main.h file.

main.h:

```

#ifndef MAIN
#define MAIN

void Userfunction(void); /*Declaration of user function*/
BOOL User_Timeout_Function(void);
void sci_rt (void);

#endif
/*=====*/
  
```



```

} while ((User_Timeout_Function()) && (Err == SCI_RX_DATA_EMPTY) );

if(User_Timeout_Function())                               /*Byte received before Timeout */
{
    if(Err == SCI_RECEIVE_OK)
    {
        Rx_Data = SCI_GetByte();                          /*Correct Data Byte received*/
        Nop
    }
    else
    {
        if ((unsigned char)Err & SCI_NOISE_ERR)
        {
            Userfunction ();
        }
        if ((unsigned char)Err & SCI_OVERRUN_ERR)
        {
            Userfunction ();
        }
        if ((unsigned char)Err & SCI_FRAMING_ERR)
        {
            Userfunction ();
        }
        if ((unsigned char)Err & SCI_PARITY_ERR)
        {
            Userfunction ();
        }
        Rx_Data = SCI_GetByte();                          /*Corrupted Data Byte received*/
    }
}                                                         /*Timeout elapsed*/
else
{
    while(1);                                             /*Transmitter or Receiver having problem */
}

/*-----Buffer Reception-----*/

Err = (SCI_GetBuffer (Buff_Rcv, (unsigned char)19));

if(Err == SCI_RECEIVE_OK)                                /*Reception of data in user buffer*/
{                                                         /*Checks the error status*/
    Nop                                                  /* Reception OK*/
}
else                                                    /*Error Occurred during reception*/
{
    if ((unsigned char)Err & SCI_NOISE_ERR)
    {
        Userfunction ();
    }
    if ((unsigned char)Err & SCI_OVERRUN_ERR)
    {
        Userfunction ();
    }
    if ((unsigned char)Err & SCI_FRAMING_ERR)
    {

```

Function Descriptions

```
        Userfunction ();
    }
    if ((unsigned char)Err & SCI_PARITY_ERR)
    {
        Userfunction ();
    }
}
#endif
/*-----
Transmission through Interrupt Driven without Buffer mode
-----*/
#ifdef SCI_ITDRV_WITHOUTBUF_TX                /*Selects interrupt mode for transmission*/
                                           /*Interrupt enable when TDRE flag is set */
    SCI_Mode(SCI_TX_ENABLE);
    if(SCI_IsTransmitCompleted())
    {
        SCI_PutByte((unsigned char)55);
        while (!(SCI_IsTransmitCompleted()));
        SCI_PutString(Buffer);                /*user pointer is copied to the global pointer*/
/* Here, user can perform other tasks or operations except transmission till the
time transmission is complete, after which user can perform transmission again*/

        while (!(SCI_IsTransmitCompleted()));
    }
#endif
/*-----
Reception through Interrupt driven without Buffer mechanism
-----*/
#ifdef SCI_ITDRV_WITHOUTBUF_RX                /* Selects interrupt mode for transmission */
                                           /*Interrupt enable when RDR register is ready to read*/
    SCI_IT_Enable((unsigned char)SCI_RECEIVE_OVERRUN);
    SCI_Mode(SCI_RX_ENABLE);

/*-----Single Byte reception-----*/
do
{
    Err = SCI_IsReceptionCompleted();
}while ((User_Timeout_Function()) && (Err == SCI_RX_DATA_EMPTY));
                                           /* Wait for the completion of current data byte reception*/
if(User_Timeout_Function())
{
    if(Err == SCI_RECEIVE_OK)
    {
                                                /*Reception OK */
        Nop
        Rx_Data = SCI_GetByte();
        Nop
    }
    else
    {
        if ((unsigned char)Err & SCI_NOISE_ERR)
        {
            Userfunction ();
        }
        if ((unsigned char)Err & SCI_OVERRUN_ERR)
        {

```

```

        Userfunction ();
    }
    if ((unsigned char)Err & SCI_FRAMING_ERR)
    {
        Userfunction ();
    }
    if ((unsigned char)Err & SCI_PARITY_ERR)
    {
        Userfunction ();
    }
    Rx_Data = SCI_GetByte();      /*User will receive the corrupted data */
}
else
{
    while(1);                    /*Transmitter or Receiver having problem */
}

/*-----Buffer Reception-----*/

SCI_GetBuffer (Buff_Rcv, (unsigned char)19);
/* Any data received before calling this function is ignored*/
/* Here, user can perform other tasks or operations except reception till the
time the function SCI_IsReceptionCompleted() returns RECEIVE_OK,
after which user can perform reception again          */

do
{
    Err = SCI_IsReceptionCompleted();
}while (Err == SCI_BUFFER_ONGOING);
    /* To be sure that the communication by this point has been completed */

if(Err == SCI_RECEIVE_OK)
{
    Nop                          /*ReceptionOK*/
}
else
{
    if ((unsigned char)Err & SCI_NOISE_ERR)
    {
        Userfunction ();
    }
    if ((unsigned char)Err & SCI_OVERRUN_ERR)
    {
        Userfunction ();
    }
    if ((unsigned char)Err & SCI_FRAMING_ERR)
    {
        Userfunction ();
    }
    if ((unsigned char)Err & SCI_PARITY_ERR)
    {
        Userfunction ();
    }
}
}

```

9.1.3 SPI

Following are the functions related to SPI:

Function Name	SPI_Init
Function Prototype	Void SPI_Init (SPI_Init_Parameter1 Init_Value1, SPI_Init_Parameter2 Init_Value2)
Behaviour Description	Initialization of the SPI. By default the SPI is put in slave mode (hardware selected), baudrate Fcpu/8, the SPI peripheral is not connected to the external pins (SPE=0), alternate function of SPI output enabled (SOD=0) and interrupts are disabled. You can change the default configuration by selecting input parameters given below.
Input Parameter 1	<p>You can pass one or more parameters by 'OR'ing them.</p> <p>SPI_DEFAULT Reset Value</p> <p>SPI_ENABLE Enables the serial peripheral output (SPI alternate functions connected to pins).</p> <p>SPI_ENABLE_IT Enables the Interrupt</p> <p>Selects the clock baudrate by selecting one of the below parameters. For SPI_BAUDRATE_4, Clock baudrate is Fcpu/4 For SPI_BAUDRATE_8, Clock baudrate is Fcpu/8, (Default baudrate value) For SPI_BAUDRATE_16, Clock baudrate is Fcpu/16. For SPI_BAUDRATE_32, Clock baudrate is Fcpu/32. For SPI_BAUDRATE_64, Clock baudrate is Fcpu/64. For SPI_BAUDRATE_128, Clock baudrate is Fcpu/128.</p> <p>Selects the clock polarity and clock phase by selecting one of the below parameters. SPI_CLK_PP_0, For CPOL=0, CPHA =0 (Default clock polarity and phase) SPI_CLK_PP_1, For CPOL=0, CPHA =1 SPI_CLK_PP_2, For CPOL=1, CPHA =0 SPI_CLK_PP_3, For CPOL=1, CPHA =1</p>

Input Parameter 2	<p>You can select master/ slave in hardware/ software mode by selecting one of the below parameters.</p> <p>SPI_MSTR_SW Selects Master in software mode</p> <p>SPI_SLAVE_SW Selects Slave in software mode</p> <p>SPI_HW Selects hardware mode. You have to manage the SS pin accordingly for selecting Master/Slave.</p>
Output Parameters	None
Required Preconditions	<ol style="list-style-type: none"> 1. SS pin must be GND for default slave mode. 2. In hardware mode, if slave has to transmit, the SS pin of the slave has to be released and made HIGH before writing in SPIDR and repute to GND to avoid write collision error. 3. Fcpu must be defined in ST7lib_config.h. 4. SPI port pin must be configured correctly in hardware.
Functions called	SPI_Clear_Flags
Postconditions	If you want to enable the interrupt, the SPI_ENABLE_IT parameter has to be passed in the SPI_Init function. After the SPI_Init function is called, you should use the macro EnableInterrupts macro to reset the Interrupt mask.
See also	SPI_Output_Disable

Note: If you want to select the *Interrupt driven* communication mode, you must enable interrupts during initialization.

Table 29. SPI_Output_Disable

Function Name	SPI_Output_Disable
Function Prototype	Void SPI_Output_Disable (void)
Behaviour Description	Disables the alternate function of the SPI output.
Input Parameters	None
Output Parameters	None
Required Preconditions	None
Functions called	None
Postconditions	If you want to enable the SPI output again, you must call SPI_Init and pass the 'SPI_DEFAULT' parameter.
See also	SPI_Init

Table 30. SPI_PutByte

Function Name	SPI_PutByte
Function Prototype	Void SPI_PutByte (unsigned char Tx_Data)
Behaviour Description	Transmits a single byte of data in SPI Polling or SPI Interrupt driven modes.
Input Parameters	Tx_Data Data byte to be transmitted.
Output Parameters	None
Required Preconditions	<ol style="list-style-type: none"> 1. SPI should be configured correctly. 2. You must define the Transmission mode (SPI Polling or SPI Interrupt driven) 3. You must enable interrupts for SPI Interrupt driven mode. 4. For SPI Interrupt driven mode, SPI_IsTransmitCompleted must have been called to ensure that there are no pending requests. 5. For SPI Interrupt driven mode, SPI_IT_Function must have been called in the Interrupt service routine.
Functions called	None
Postconditions	Call SPI_IsTransmitCompleted after this function to get the transmission status.
See also	SPI_IsTransmitCompleted

Notes:

- The above function is only for **SPI Polling** or **SPI Interrupt driven** modes.
- It is recommended to add timeout protection when using this function.
- For transmission in software slave mode, you must define SPI_SLAVE_CONFIG in ST7lib_config.h.

Table 31. SPI_PutString

Function Name	SPI_PutString
Function Prototype	SPI_TxErrCode_t SPI_PutString (const unsigned char *PtrToString)
Behaviour Description	Transmits data string from the user defined address for SPI Polling mode. The data transmission will stop if any error occurs during transmission. The transmission status will be returned.
Input Parameters	*PtrToString Start address of the user string.
Output Parameters	SPI_TX_WCOL If write collision error occurs. SPI_TX_MODF If master mode fault occurs. SPI_TRANSMIT_OK If there is no error in transmission.
Required Preconditions	1. SPI should be configured correctly. 2. You must define ' SPI Polling ' mode in ST7lib_config.h.
Functions called	None
Postconditions	None
See also	SPI_PutString (SPI Interrupt driven mode)

Notes:

- The above function is only for **SPI Polling** mode.
- For transmission in software slave mode, you must define SPI_SLAVE_CONFIG in ST7lib_config.h.

Caution: The application can lose control if the SPI is disabled while using this function in polling mode.

Table 32. SPI_PutBuffer

Function Name	SPI_PutBuffer
Function Prototype	SPI_TxErrCode_t SPI_PutBuffer (const unsigned char *PtrToBuffer, unsigned char NbOfBytes)
Behaviour Description	Transmits data bytes from the user defined area for SPI Polling mode. The data transmission will stop if any error occurs during transmission. The transmission status will be returned.
Input Parameter 1	*PtrToBuffer Start address of the user buffer.
Input Parameter 2	NbOfBytes Number of data bytes to be transmitted.
Output Parameters	SPI_TX_WCOL If write collision error occurs. SPI_TX_MODF If master mode fault occurs. SPI_TRANSMIT_OK If there is no error in transmission.
Required Preconditions	1. SPI should be configured correctly. 2. You must define SPI Polling transmission mode in ST7lib_config.h.
Functions called	None
See also	SPI_PutBuffer (SPI Interrupt driven mode)

Notes:

- The above function is only for **SPI Polling** mode.
- For transmission in software slave mode, you must define SPI_SLAVE_CONFIG in ST7lib_config.h.

Caution: The application can lose control if the SPI is disabled while using this function in polling mode.

Table 33. SPI_PutString

Function Name	SPI_PutString
Function Prototype	Void SPI_PutString (const unsigned char *PtrToString)
Behaviour Description	Starts transmission of data string in the interrupt service routine, from the user defined area for SPI Interrupt driven mode.
Input Parameters	*PtrToString Start address of the user string.
Output Parameters	None
Required Preconditions	<ol style="list-style-type: none"> 1. The SPI should be configured correctly. 2. You must define SPI Interrupt driven mode in ST7lib_config.h. 3. You must enable interrupts for this mode. 4. For SPI Interrupt driven mode, SPI_IT_Function must have been called in the Interrupt service routine.
Functions called	None
Postconditions	SPI_IsTransmitCompleted can be called after this function to get the transmission status.
See also	SPI_IsTransmitCompleted, SPI_PutString (SPI Polling mode)

Notes:

- The above function is only for **SPI Interrupt driven** mode.
- For software slave mode transmission, you must define SPI_SLAVE_CONFIG in ST7lib_config.h.

Caution:

- Do not access the string until transmission is completed
- Data transmission will stop if any error occurs during transmission.

Table 34. SPI_PutBuffer

Function Name	SPI_PutBuffer
Function Prototype	Void SPI_PutBuffer (const unsigned char *PtrToBuffer, unsigned char NbOfBytes)
Behaviour Description	Starts transmission of data in the interrupt service routine, from the user defined area for SPI Interrupt driven mode.
Input Parameter 1	*PtrToBuffer Start address of the user buffer.
Input Parameter 2	NbOfBytes Number of data bytes to be transmitted.
Output Parameters	None
Required Preconditions	<ol style="list-style-type: none"> 1. The SPI should be configured correctly. 2. You must define the transmission mode as SPI Interrupt driven in ST7lib_config.h. 3. You must enable interrupts for this mode. 4. For SPI Interrupt driven mode, SPI_IT_Function must have been called in the Interrupt service routine.
Postconditions	You can call 'SPI_IsTransmitCompleted' after this function to get the transmission status.
See also	SPI_IsTransmitCompleted, SPI_PutBuffer (SPI Polling mode)

Notes:

- The above function is only for **SPI Interrupt driven** mode.
- For transmission in software slave mode, you must define SPI_SLAVE_CONFIG in ST7lib_config.h.

Caution:

- Do not access the string until transmission is completed.
- Data transmission will stop if any error occurs during transmission.

Table 35. SPI_IsTransmitCompleted

Function Name	SPI_IsTransmitCompleted
Function Prototype	SPI_TxErrCode_t SPI_IsTransmitCompleted (void)
Behaviour Description	Checks for errors, checks for pending requests and returns the transmission status.
Input Parameters	None
Output Parameters	<p>SPI_TX_WCOL If write collision error occurs.</p> <p>SPI_TX_MODF If master mode fault occurs.</p> <p>SPI_TRANSMIT_OK If there is no error in transmission and all data bytes are transmitted.</p> <p>SPI_TX_BUFFER_ONGOING ¹⁾ If all the data bytes from user buffer are not transmitted.</p> <p>SPI_TX_STRING_ONGOING ¹⁾ If the complete string is not transmitted.</p>
Required Preconditions	None
Functions called	None
Postconditions	None
See also	None

1) These Parameters are returned in **SPI Interrupt driven** mode only.

Notes:

- The above function is for **SPI Polling** and **SPI Interrupt driven** modes.
- In '**SPI Polling**' mode, this function is called only after SPI_PutByte function.

Table 36. SPI_GetByte

Function Name	SPI_GetByte
Function Prototype	Unsigned char SPI_GetByte (void)
Behaviour Description	Returns the most recent Byte received in SPI Polling or SPI Interrupt driven mode.
Input Parameters	None
Output Parameters	Unsigned char Returns the received data byte.
Required Preconditions	<ol style="list-style-type: none"> 1. The SPI should be configured correctly. 2. You must define SPI Polling or SPI Interrupt driven mode in ST7lib_config.h. 3. You must enable interrupts for SPI Interrupt driven mode. 4. In both SPI Polling and SPI Interrupt driven modes you must call SPI_IsReceptionCompleted before this function to check the reception status. 5. For SPI Interrupt driven mode, SPI_IT_Function must have been called in the Interrupt service routine.
Functions called	None
Postconditions	None
See also	SPI_IsReceptionCompleted

Notes:

- The above function is for **SPI Polling** or **SPI Interrupt driven** mode.
- It is recommended to add a timeout protection when using this function.

Table 37. SPI_GetString

Function Name	SPI_GetString
Function Prototype	SPI_RxErrCode_t SPI_GetString (unsigned char *PtrToString)
Behaviour Description	Receives the data string in SPI Polling mode and stores it in a user defined area. The data reception will stop if any error occurs during reception. The reception status will be returned.
Input Parameters	*PtrToString Start address of the String
Output Parameters	SPI_RX_MODF If master mode fault occurs. SPI_RX_OVR If overrun condition occurs. SPI_RECEIVE_OK If there is no error in reception.
Required Preconditions	1. The SPI must be configured correctly. 2. You must define SPI Polling mode in ST7lib_config.h.
Functions called	None
Postconditions	None
See also	SPI_GetString (SPI Interrupt driven mode)

Note: The above function is only for **SPI Polling** mode.

Caution: The application can lose control if the SPI is disabled while using this function in polling mode.

Table 38. SPI_GetBuffer

Function Name	SPI_GetBuffer
Function Prototype	SPI_RxErrCode_t SPI_GetBuffer (unsigned char *PtrToBuffer, unsigned char NbOfBytes)
Behaviour Description	Receives a number of data bytes in SPI Polling mode and stores them in a user defined area. The data reception will stop if any error occurs during reception. The reception status will be returned.
Input Parameter 1	*PtrToBuffer Start address of the user buffer.
Input Parameter 2	NbOfBytes Number of bytes to be received.
Output Parameters	SPI_RX_MODF If master mode fault occurs. SPI_RX_OVR If overrun condition occurs. SPI_RECEIVE_OK If there is no error in reception.
Required Preconditions	1. The SPI should be configured correctly. 2. You must define SPI Polling mode in ST7lib_config.h.
Functions called	None
See also	SPI_GetBuffer (SPI Interrupt driven mode)

Note: The above function is only for **SPI Polling** mode.

Caution: The application can lose control if the SPI is disabled while using this function in polling mode.

Table 39. SPI_GetString

Function Name	SPI_GetString
Function Prototype	Void SPI_GetString (unsigned char *PtrToString)
Behaviour Description	Starts reception of a data string in SPI Interrupt driven mode in the interrupt service routine and stores it in a user defined area.
Input Parameters	*PtrToString Start address of the location where the string is to be placed.
Output Parameters	None
Required Preconditions	<ol style="list-style-type: none"> 1. The SPI should be configured correctly. 2. You must define SPI Interrupt driven reception mode in ST7lib_config.h. 3. You must enable interrupts for this mode. 4. For SPI Interrupt driven mode, SPI_IT_Function must have been called in the Interrupt service routine.
Functions called	None
Postconditions	You must call SPI_IsReceptionCompleted after this, to check the reception status.
See also	SPI_IsReceptionCompleted, SPI_GetString (SPI Polling mode)

Note: The above function is only for **SPI Interrupt driven** mode.

Caution:

- Take care not to access the string until reception is complete.
- Any data received before calling this function is ignored.
- The data reception will stop if any error occurs during reception.

Table 40. SPI_GetBuffer

Function Name	SPI_GetBuffer
Function Prototype	Void SPI_GetBuffer (unsigned char *PtrToBuffer, unsigned char NbOfBytes)
Behaviour Description	Starts reception of data in the interrupt service routine and stores it in user defined area for SPI Interrupt driven mode.
Input Parameter 1	*PtrToBuffer Start address of the user buffer.
Input Parameter 2	NbOfBytes Number of bytes to be received.
Output Parameters	None
Required Preconditions	<ol style="list-style-type: none"> 1. The SPI should be configured correctly. 2. You must define the SPI Interrupt driven reception mode in ST7lib_config.h. 3. You must enable interrupts for this mode. 4. For SPI Interrupt driven mode, SPI_IT_Function must have been called in the Interrupt service routine.
Functions called	None
Postconditions	You must call SPI_IsReceptionCompleted after this to check the reception status.
See also	SPI_IsReceptionCompleted, SPI_GetBuffer (SPI Polling mode)

Note: The above function is only for **SPI Interrupt driven** mode.

Caution:

- Take care not to access the string until reception is complete.
- Any data received before calling this function is ignored
- The data reception will stop if any error occurs during reception.

Table 41. SPI_IsReceptionCompleted

Function Name	SPI_IsReceptionCompleted
Function Prototype	SPI_RxErrCode_t SPI_IsReceptionCompleted (void)
Behaviour Description	<p>For reception of a set of data in SPI Interrupt driven mode, this function checks for the completion of the reception or the occurrence of an error and returns the reception status.</p> <p>For reception of single byte of data in either SPI Polling or SPI Interrupt driven mode, it checks if a data byte has been received and is ready for processing. It returns SPI_RX_DATA_EMPTY until the data byte is received and returns the reception status afterwards.</p>
Input Parameters	None
Output Parameters	<p>SPI_RX_MODF If master mode fault occurs.</p> <p>SPI_RX_OVR If overrun condition occurs.</p> <p>SPI_RECEIVE_OK If the reception is completed without any error.</p> <p>SPI_RX_BUFFER_ONGOING ¹⁾ If the buffer is not full.</p> <p>SPI_RX_STRING_ONGOING ¹⁾ If the complete string is not received in the user buffer.</p> <p>SPI_RX_DATA_EMPTY ²⁾ If no data byte is received.</p>
Required Preconditions	None
Functions called	None
Postconditions	<p>1.For single byte reception, if the byte is received, then SPI_GetByte can be called after this function.</p> <p>2.SPI_Clear_Flags can be called to clear the error and status flags, if required.</p>
See also	None

1) These Parameters are returned in **SPI Interrupt driven** mode only.

2) This Parameter is returned in case of single byte reception only, for both **SPI Polling** and **SPI Interrupt driven** modes.

Notes:

- In **SPI Polling** mode, this function is used in conjunction with SPI_GetByte only.
 - If this function is called before any reception request is made, it will check for single byte reception, and will return SPI_RX_DATA_EMPTY until the first data byte is received, and returns the reception status when reception is complete.
- If a reception request is over, this function will return the error status of that request only once. If this function is called again (before making next reception request), then the function will check for single byte reception.

Table 42. SPI_IT_Function

Function Name	SPI_IT_Function
Function Prototype	Void SPI_IT_Function (void)
Behaviour Description	Transmits or receives data in <i>SPI Interrupt driven</i> mode. You must call this function in the interrupt service routine.
Input Parameters	None
Output Parameters	None
Required Preconditions	You must have called transmission or reception function in <i>SPI Interrupt driven</i> mode before this.
Functions called	None
Postconditions	None
See also	None

Note: You must use this function only in the Interrupt service routine.

Caution: Special care must be taken, while you write your own code along with this function inside the interrupt service routine. Otherwise, data transfer synchronisation will be affected, which may lead to data loss or overrun error.

Table 43. SPI_Clear_Flags

Function Name	SPI_Clear_Flags
Function Prototype	Void SPI_Clear_Flags (void)
Behaviour Description	Clears the SPI error (WCOL, MODF and OVR bits of SPICSR register) and status (SPIF bit of SPICSR) flags.
Input Parameters	None
Output Parameters	None
Required Preconditions	Transmission or Reception must have taken place.
Functions called	None
Postconditions	None
See also	SPI_IsTransmitCompleted SPI_IsReceptionCompleted

Note: You can call this function whenever you want to force the error and status flags to be cleared.

Caution: Do not call this function if a reception request is ongoing as it will corrupt the reception status by clearing all the flags and you will not receive any error status.

EXAMPLE:

The following C program shows the use of SPI functions.

Program Description:

This program runs the following sequence for the SPI for **SPI Polling** and **SPI Interrupt driven** modes:

1. Transmits a single byte passed by the user and receives single byte of data,
2. Transmits and receives the 10 bytes of data,

You can select one pair of the following communication modes, for transmission and reception respectively:

SPI_POLLING_TX	-- For Transmission mode
SPI_POLLING_RX	-- For Reception mode
SPI_ITDRV_WITHOUTBUF_TX	- For Transmission mode
SPI_ITDRV_WITHOUTBUF_RX	-- For Reception mode

/* User can use a time out function to handle the fault in which the control will get stuck in side a loop.This function should have the Boolean return, i.e it should return TRUE if the expected wait Time is not elapsed and FALSE if it is elapsed.*/

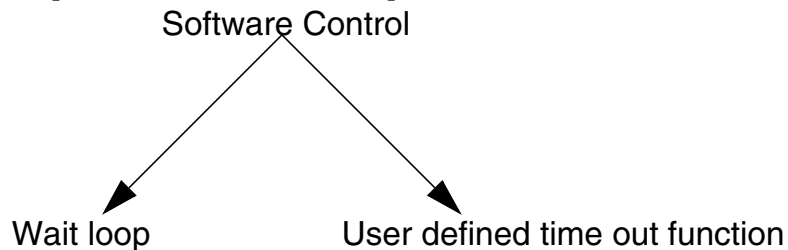

/*-----*/

The following variables are declared in main.h file.

main.h:

```
#ifndef MAIN
#define MAIN
```

```
BOOL User_Timeout_Function(void) ; /* Prototypes of user function */
void User_Function(void);
void SPI_User_IT_Routine (void) ;//newly added
```

```
/* Declaration of all global variables used in main.c */
```

```
#define buf_size 0x0A
#define My_Data (unsigned char)0x55
static unsigned int Timeoutcount;
```

```
#endif
```

```
/*-----*/
```

```

/* Program Start */

#include "ST7lib_config.h"           /*List of all ST7 devices and communication mode */
#include "main.h"                   /* Declaration of prototypes of user defined functions used in main.c */

void main(void);

void main(void)
{
    unsigned char NbOfBytes_get = 10;
    unsigned char NbOfBytes_put = 10;
    unsigned char Rx_Data;
    unsigned char Buff_Test[buf_size];
    unsigned char Buff[buf_size] = {0x00, 0x55, 0xAA, 0xFF, 0x00, 0x55, 0xAA, 0xFF, 0x00, 0x55};
    SPI_TxErrCode_t Temp1= 0x00 ;
    SPI_RxErrCode_t Temp2= 0x00 ;

    SPI_Init((((unsigned char)SPI_DEFAULT | ((unsigned char)SPI_ENABLE |
        ((unsigned char)SPI_ENABLE_IT | ((unsigned char)SPI_BAUDRATE_4 |
        ((unsigned char)SPI_CLK_PP_0))))), SPI_MSTR_SW);
        /* SPI Initialised in master software mode, Serial peripheral output
        enabled, Interrupt enabled, CPOL=0, CPHA=1 and baudrate is 2MHz */
    EnableInterrupts                /* Interrupt mask is reset for enabling interrupt */

    /*=====
        Transmission through 'Polling' mode
        =====*/
#ifdef SPI_POLLING_TX
    /* Single byte data transmission */
    SPI_PutByte (My_Data) ;
    Temp1 = SPI_IsTransmitCompleted();
    while (!(User_Timeout_Function()) && (Temp1 != SPI_TRANSMIT_OK) )
    {
        Temp1 = SPI_IsTransmitCompleted() ;
    }
    if (!(User_Timeout_Function()))
    {
        switch (Temp1)
        {
            case (SPI_TX_MODF + SPI_TX_WCOL) :
            case (SPI_TX_MODF) :
            case (SPI_TX_WCOL) :
                User_Function();                /* Error Management */
                break;
            default:                            /* If none of the above condition is met */
                User_Function();
                break;
        }
    }

    /* Transmission of 10 data bytes from user buffer */
    switch(SPI_PutBuffer(Buff, (unsigned char)10))

    {
        case (SPI_TX_MODF + SPI_TX_WCOL) :

```

```

    case (SPI_TX_MODF):
    case (SPI_TX_WCOL):
        User_Function();                                /* Error Management */
        break;
    case SPI_TRANSMIT_OK:                                /*Transmission is successful */
        break;
    default:                                            /* If none of the above condition is met */
        User_Function();
        break;
}
#endif
/*=====
    Reception through 'Polling' mode
=====*/
#ifdef SPI_POLLING_RX
                                                    /* Single byte data reception */
Temp2 = SPI_IsReceptionCompleted() ;
while ((User_Timeout_Function()) && (Temp2 == SPI_RX_DATA_EMPTY))
{
    Temp2 = SPI_IsReceptionCompleted() ;
}
                                                    /* Waiting for data byte reception */
if (User_Timeout_Function())
{
    switch (Temp2)
    {
        case (SPI_RX_MODF + SPI_RX_OVR):
        case (SPI_RX_MODF):
        case (SPI_RX_OVR):
            User_Function();                            /* Error Management */
            Rx_Data = SPI_GetByte () ;                  /* Corrupted data byte received */
            break;
        case SPI_RECEIVE_OK:                            /* Reception successful */
            Rx_Data = SPI_GetByte () ;
            break;
        default:                                        /* If none of the above condition is met */
            User_Function();
            break;
    }
}
else
{
    while (1) ;
        /* Handle time out as Transmitter/Receiver is having some problem */
}
                                                    /* Reception of set of data */
switch ((SPI_GetBuffer(Buff_Test, (unsigned char)10))
{
    case (SPI_RX_MODF + SPI_RX_OVR):
    case (SPI_RX_MODF):
    case (SPI_RX_OVR):
        User_Function();                                /* Error Management */
        break;
    case SPI_RECEIVE_OK:                                /* Reception is successful */
        break;
}

```

```

        default:                                /* If none of the above condition is met */
            User_Function();
            break;
    }
#endif
/*=====
    Transmission through 'Interrupt Driven without Buffer Mode'
=====*/
#ifdef SPI_ITDRV_WITHOUTBUF_TX
                                                    /* Single byte transmission */
SPI_PutByte (My_Data) ;

/* Here, user can perform other tasks or operations except transmission
till the time transmission is complete, after which user can perform
transmission again */

Temp1 = SPI_IsTransmitCompleted() ;
while ((Temp1 == SPI_TX_BUFFER_ONGOING) && (Temp1 == SPI_TX_STRING_ONGOING))
                                                    /* Wait for transmission completion */
{
    Temp1 = SPI_IsTransmitCompleted() ;
}
switch (Temp1)
{
    case (SPI_TX_MODF + SPI_TX_WCOL) :
    case (SPI_TX_MODF) :
    case (SPI_TX_WCOL) :
        User_Function();                                /* Error Management */
        break;
    case SPI_TRANSMIT_OK:                            /* Transmission is successful */
        break;
    default:                                        /* If none of the above condition is met */
        User_Function();
        break;
}
                                                    /* Transmission of 10 data bytes from user buffer */
                                                    /* User pointer is copied to the global pointer */
SPI_PutBuffer (Buff, NbOfBytes_put);

/* Here, user can perform other tasks or operations except transmission
till the time transmission is complete, after which user can perform
transmission again */

Temp1 = SPI_IsTransmitCompleted() ;
while ((User_Timeout_Function()) && (Temp1 == SPI_TX_BUFFER_ONGOING))
{
    Temp1 = SPI_IsTransmitCompleted() ;
} /* To be sure that the communication by this point has been completed */
if (User_Timeout_Function())
{
    switch (Temp1)
    {
        case (SPI_TX_MODF + SPI_TX_WCOL) :
        case (SPI_TX_MODF) :
        case (SPI_TX_WCOL) :

```

Function Descriptions

```
        User_Function();                                /* Error Management */
        break;
    case SPI_TRANSMIT_OK:                               /* Transmission successful */
        break;
    default:                                           /* If none of the above condition is met */
        User_Function();
        break;
    }
}
else
{
    while (1);

        /* Time-Out elapsed without transmission completion. Error in
        communication and user should handle the case */
}
#endif
/*=====
Reception through 'Interrupt Driven without Buffer Mode'
=====*/
#ifdef SPI_ITDRV_WITHOUTBUF_RX
/* Single byte reception */
Temp2 = SPI_IsReceptionCompleted();
while ((User_Timeout_Function()) && (Temp2 == SPI_RX_DATA_EMPTY))
/* Waits for data byte reception */
{
    Temp2 = SPI_IsReceptionCompleted();
}
if (User_Timeout_Function())
{
    switch (Temp2)
    {
        case (SPI_RX_MODF + SPI_RX_OVR):
        case (SPI_RX_MODF):
        case (SPI_RX_OVR):
            User_Function();                                /* Error Management */
            Rx_Data = SPI_GetByte ();
/* User will get the corrupted data */
            break;
        case SPI_RECEIVE_OK:                             /* Reception successful */
            Rx_Data = SPI_GetByte ();
            break;
        default:                                         /* If none of the above condition is met */
            User_Function();
            break;
    }
}
else
{
    while (1);

        /* Time-Out elapsed without reception completion. Error in
        communication and user should handle the case */
}

/* Reception of the data in the user buffer */
SPI_GetBuffer (Buff_Test, NbOfBytes_get);
/* Any data received before calling this function is ignored */
```

```

        /* Here, user can perform other tasks or operations except reception till
        the time re-reception is complete, after which user can perform reception
        again */

Temp2 = SPI_IsReceptionCompleted();
while ((User_Timeout_Function()) && (Temp2 == SPI_RX_BUFFER_ONGOING))
{
    Temp2 = SPI_IsReceptionCompleted();
}    /* To be sure that the communication by this point has been completed */

if (User_Timeout_Function())
{
    switch (Temp2)
    {
        case (SPI_RX_MODF + SPI_RX_OVR):
        case (SPI_RX_MODF):
        case (SPI_RX_OVR):
            User_Function();                /* Error Management */
            break;
        case SPI_RECEIVE_OK:                /* Reception successful */
            break;
        default:                            /* If none of the above condition is met */
            User_Function();
            break;
    }
}
else
{
    while (1);

                                /* Time-Out elapsed without reception completion. Error in
                                communication and user should handle the case */
}
#endif
}

/*-----
ROUTINE NAME : SPI_User_IT_Routine
INPUT      : None
OUTPUT     : None
DESCRIPTION : Control comes into this routine when an interrupt is generated.
            User can use the SPI interrupt service routine function or he
            can write his own code inside this routine at his own risk. The
            data transfer synchronisation may be affected if user includes
            his own code along with SPI ISR function.
COMMENTS   : None
-----*/

#ifdef _HIWARE_                                /* Test for HIWARE Compiler */
#pragma TRAP_PROC SAVE_REGS                    /* Additional registers will be saved */
#else
#ifdef _COSMIC_                                /* Test for Cosmic Compiler */
@interrupt                                    /* Cosmic interrupt handling */
#else
#error "Unsupported Compiler!"                /* Compiler Defines not found! */
#endif
#endif

```

Function Descriptions

```
#endif
```

```
void SPI_User_IT_Routine (void)
```

```
{  
    SPI_IT_Function () ;                               /* SPI Interrupt service routine function */  
}
```

```
/*-----  
                USER FUNCTIONS  
-----*/
```

```
BOOL User_Timeout_Function(void)
```

```
{  
    while(Timeoutcount < 50000)  
    {  
        Timeoutcount++ ;  
        return (TRUE) ;                               /* Time-out not elapsed */  
    }  
    return (FALSE) ;                                  /* Time-out elapsed */  
}
```

```
void User_Function(void)
```

```
{  
    SPI_Clear_Flags () ;                               /* Clears error and status flags */  
}
```

9.1.4 I2C MASTER

Following are the functions related to both Single master and multi master I2C.

Function Name	I2C_Init
Function Prototype	Void I2C_Init (I2C_Init_Param Init_Value)
Behaviour Description	Initialization of I2C. By default, I2C peripheral is enabled, acknowledge and interrupts are disabled. If single master I2C device is selected, I2C will be idle. You can change the default configuration by selecting the input parameters given below. You can pass one or more parameters by logically 'OR'ing them.
Input Parameters	I2C_DEFAULT_PARAM1 Load all I2C registers with default value. Only I2C peripheral is enabled (PE bit is set). I2C_ENABLE_ACK Enables acknowledge. I2C_IT_ENABLE Enables interrupt
Output Parameters	None
Required Preconditions	<ol style="list-style-type: none"> 1. I/O port should be configured correctly. 2. If you want to configure single master I2C, the ST72F65 device must be selected.
Functions called	None
Postconditions	<ol style="list-style-type: none"> 1. If you want to enable interrupts, the I2C_IT_ENABLE parameter has to be passed in the I2C_Init function. After the I2C_Init function is called, you should use the EnableInterrupts macro to reset the Interrupt mask. 2. For single master I2C, to configure I2C in master mode, you have to call I2C_Generate_Start after this function .
See also	None

Note: If you select *I2C Interrupt driven* communication mode, interrupts must be enabled during initialization.

Table 44. I2C_MultiMaster_Config

Function Name	I2C_MultiMaster_Config
Function Prototype	Void I2C_MultiMaster_Config (void)
Behaviour Description	Configures I2C as multimaster I2C device
Input Parameters	None**
Output Parameters	None
Required Preconditions	1. ST72F521/ ST72F63B/ ST72325 devices must be selected for multimaster I2C. 2. I2C_Init must have been called
Functions called	None
Postconditions	I2C is configured in slave mode. To configure in master mode, you have to call I2C_Generate_Start after this.
See also	None

*This is only valid for ST72F521/ ST72F63B/ ST72325 devices.

**The input parameter, which was available in earlier versions of ST7 library, has been removed.

Table 45. I2C_Select_Speed

Function Name	I2C_Select_Speed
Function Prototype	Void I2C_Select_Speed (I2C_Speed_Param Speed_Value, unsigned int I2C_Speed)
Behaviour Description	Selects the I2C clock speed both in standard and fast speed modes.
Input Parameter 1	I2C_DEFAULT_PARAM2 Sets standard speed mode I2C_FASTSPEED Sets fast speed mode
Input Parameter 2	I2C_Speed You can select any value from 0 to 400. Standard speed mode range: 0 to 100 kHz Fast speed mode range: 101 to 400 kHz
Output Parameters	None
Required Preconditions	<ol style="list-style-type: none"> 1. I2C_Init must have been called. 2. Fcpu must be defined in ST7lib_config.h. 3. For multimaster I2C configuration the I2C_MultiMaster_Config function must have been called. 4. If you enter speed ranges from 101 to 400 kHz, the parameter 'I2C_FASTSPEED' must be selected in input parameter 1.
Functions called	None
Postconditions	None
See also	None

Note: I2C speed is strongly dependant on the R and C wired on the lines, F_{cpu} and V_{dd} values, and not solely on the value programmed in I2CCCR register. So you must take account of the R and C values. You must not pass the speed value less than the minimum speed limit. (For ex., minimum speed limit for $F_{cpu} = 8\text{MHz}$ is 16 kHz).

Table 46. I2C_Generate_Start

Function Name	I2C_Generate_Start
Function Prototype	Void I2C_Generate_Start (void)
Behaviour Description	Generates start condition.
Input Parameters	None
Output Parameters	None
Required Preconditions	1. I2C_Select_Speed must have been called. 2. In I2C Interrupt driven mode, I2C_IT_Function must have been called in the Interrupt service routine.
Functions called	None
Postconditions	I2C_IsTransmitCompleted should be called after this to ensure that start condition is generated correctly.
See also	None

Notes:

- A start condition is not generated unless I2C_Init or I2C_Generate_Stop is called before this function.
- When start condition is generated for ST72F65/ST72F521/ ST72F63B/ ST72325 devices, the I2C switches over from Idle/Slave modes to Master mode.

Table 47. I2C_Load_Address

Function Name	I2C_Load_Address
Function Prototype	Void I2C_Load_Address (unsigned char Addr_Byte, I2C_Mode_Param Mode_Value)
Behaviour Description	In master mode, transmits the address byte to select the slave device.
Input Parameter 1	Addr_Byte You can select any value from 00 to FFh.
Input Parameter 2	You have to pass one of the below parameters. I2C_TX_MODE Enters into transmitter mode after slave address is transmitted. I2C_RX_MODE Enters into receiver mode after slave address is transmitted. I2C_SUB_ADD You must pass this parameter, if slave sub-address has to be transmitted.
Output Parameters	None
Required Preconditions	1. I2C_Generate_Start must have been called. 2. In <i>I2C Interrupt driven</i> mode, I2C_IT_Function must have been called in the Interrupt service routine.
Functions called	None
Postconditions	If you want to transmit the sub-address (the slave address where the transmitted data to be received, in case of transmission or the slave address from where data to be transmitted, in case of reception), this function has to be called again.
See also	None

Table 48. I2C_PutByte

Function Name	I2C_PutByte
Function Prototype	Void I2C_PutByte (unsigned char Tx_Data)
Behaviour Description	Transmits a single byte of data in <i>I2C Polling</i> or <i>I2C Interrupt driven</i> mode.
Input Parameters	Tx_Data Data byte to be transmitted.
Output Parameters	None
Required Preconditions	<ol style="list-style-type: none"> 1. I2C_Load_Address must have been called (If I2C is configured in master transmitter mode). 2. You must define <i>I2C Polling</i> or <i>I2C interrupt driven</i> transmission mode in ST7lib_config.h. 3. You must enable interrupts in <i>I2C interrupt driven</i> mode. 4. In <i>I2C interrupt driven</i> mode I2C_IsTransmitCompleted must have been called to ensure that there are no pending requests. 5. In <i>I2C Interrupt driven</i> mode, I2C_IT_Function must have been called in the Interrupt service routine.
Functions called	None
Postconditions	I2C_IsTransmitCompleted can be called after this function to get the transmission status.
See also	None

Notes:

- The above function is for ***I2C Polling*** or ***I2C Interrupt driven*** mode.
- It is recommended to add a timeout protection when using this function.

Table 49. I2C_PutString

Function Name	I2C_PutString
Function Prototype	I2C_TxErrCode_t I2C_PutString (const unsigned char *PtrToString)
Behaviour Description	Transmits data string in I2C Polling mode from the user defined area. Data transmission will stop if any error occurs during transmission. The transmission status will be returned.
Input Parameters	*PtrToString Start address of the user string.
Output Parameters	I2C_TX_AF If Acknowledge failure has occurred. I2C_TX_ARLO* If Arbitration lost is detected. I2C_TX_BERR* If misplaced start or stop condition detected. I2C_DATA_TX_OK If there is no error in transmission.
Required Preconditions	1. I2C_Load_Address must have been called (If I2C is configured in master transmitter mode). 2. You must define I2C Polling mode in ST7lib_config.h.
Functions called	None
Postconditions	None
See also	I2C_PutString (I2C Interrupt driven mode)

* This is applicable only in multimaster I2C.

Note: The above function is only for **I2C Polling** mode.

Caution: The application can lose control if the I2C is disabled while using this function.

Table 50. I2C_PutBuffer

Function Name	I2C_PutBuffer
Function Prototype	I2C_TxErrCode_t I2C_PutBuffer (const unsigned char *PtrToBuffer, unsigned char NbOfBytes)
Behaviour Description	Transmits data string in I2C Polling mode from the user defined area. The data transmission will stop if any error occurs during transmission. The transmission status will be returned.
Input Parameter 1	*PtrToBuffer Start address of the user buffer.
Input Parameter 2	NbOfBytes Number of data bytes to be transmitted.
Output Parameters	I2C_TX_AF If Acknowledge failure has occurred. I2C_TX_ARLO* If Arbitration lost is detected. I2C_TX_BERR* If misplaced start or stop condition detected. I2C_DATA_TX_OK If sub-address is successfully transmitted or there is no error in data transmission.
Required Preconditions	1. I2C_Load_Address must have been called (If I2C is configured in the master transmitter mode). 2. You must define I2C Polling mode in ST7lib_config.h.
Functions called	None
Postconditions	None
See also	I2C_PutBuffer (I2C Interrupt driven mode)

* This is applicable only in multimaster I2C.

Note: The above function is only for **I2C Polling** mode.

Caution: The application can lose control if I2C is disabled when using this function in I2C Polling mode.

Table 51. I2C_PutString

Function Name	I2C_PutString
Function Prototype	Void I2C_PutString (const unsigned char *PtrToString)
Behaviour Description	Starts transmission of a data string in I2C interrupt driven mode from the user defined area.
Input Parameters	*PtrToString Start address of the user string.
Output Parameters	None
Required Preconditions	<ol style="list-style-type: none"> 1. I2C_Load_Address must have been called (If I2C is configured in master transmitter mode). 2. You must define I2C interrupt driven mode in ST7lib_config.h. 3. I2C_IsTransmitCompleted must have been called to ensure that there are no pending requests. 4. You must enable interrupt for this mode. 5. I2C_IT_Function must have been called in the Interrupt service routine.
Functions called	None
Postconditions	I2C_IsTransmitCompleted can be called after this function to get the transmission status.
See also	I2C_PutString (I2C Polling mode)

Note: The above function is only for **I2C Interrupt driven** mode.

Caution:

- Take care not to access the string until transmission is complete.
- The data transmission will stop if any error occurs during transmission.

Table 52. I2C_PutBuffer

Function Name	I2C_PutBuffer
Function Prototype	Void I2C_PutBuffer (const unsigned char *PtrToBuffer, unsigned char NbOfBytes)
Behaviour Description	Starts transmission of data from the user defined area for <i>I2C interrupt driven</i> mode.
Input Parameter 1	*PtrToBuffer Start address of the user buffer.
Input Parameter 2	NbOfBytes Number of data bytes to be transmitted.
Output Parameters	None
Required Preconditions	<ol style="list-style-type: none"> 1. I2C_Load_Address must have been called (If I2C is configured in master transmitter mode). 2. You must define <i>I2C interrupt driven</i> mode in ST7lib_config.h. 3. I2C_IsTransmitCompleted must have been called to ensure that there are no pending requests. 4. You must enable interrupts for this mode. 5. In <i>I2C Interrupt driven</i> mode, I2C_IT_Function must have been called in the Interrupt service routine.
Functions called	None
Postconditions	I2C_IsTransmitCompleted can be called after this function to get the transmission status.
See also	I2C_PutBuffer (<i>I2C Polling</i> mode)

Note: The above function is only for ***I2C Interrupt driven*** mode.

Caution:

- Take care not to access the string until transmission is complete.
- The data transmission will stop if any error occurs during transmission.

Table 53. I2C_IsTransmitCompleted

Function Name	I2C_IsTransmitCompleted
Function Prototype	I2C_TxErrCode_t I2C_IsTransmitCompleted (void)
Behaviour Description	Checks for any error during transmission and returns the error status. It also checks for any pending requests.
Input Parameters	None
Output Parameters	<p>I2C_TX_AF If Acknowledge failure has occurred.</p> <p>I2C_TX_ARLO ¹⁾ If Arbitration lost is detected.</p> <p>I2C_TX_BERR ¹⁾ If misplaced start or stop condition detected.</p> <p>I2C_ADD_TX_OK If there is no error in transmission of address bytes.</p> <p>I2C_HEADERADD_TX_OK ¹⁾ If there is no error in transmission of header byte.</p> <p>I2C_START_OK If there is no error in start condition generation</p> <p>I2C_DATA_TX_OK If there is no error in transmission and all data bytes are transmitted.</p> <p>I2C_TX_BUFFER_ONGOING ²⁾ If all the data bytes from user buffer are not transmitted.</p> <p>I2C_TX_STRING_ONGOING ²⁾ If the complete string is not transmitted.</p>
Required Preconditions	None
Functions called	None
Postconditions	I2C_Error_Clear can be called to clear the error and status flags, if required.
See also	None

1) This is applicable only in multimaster I2C device.

2) These Parameters are returned in **I2C interrupt driven** mode only.

Notes:

- The above function is for **I2C Polling** or **I2C Interrupt driven** mode.
- In **I2C Polling** mode, this function is used in conjunction with I2C_PutByte only.

Table 54. I2C_GetByte

Function Name	I2C_GetByte
Function Prototype	Unsigned char I2C_GetByte (void)
Behaviour Description	Returns the most recent Byte received in <i>I2C Polling</i> or <i>I2C interrupt driven</i> mode.
Input Parameters	None
Output Parameters	Unsigned char Returns the received data byte.
Required Preconditions	<ol style="list-style-type: none"> 1. I2C_Load_Address must have been called if master receiver. 2. You must define <i>I2C Polling</i> or <i>I2C interrupt driven</i> reception mode in ST7lib_config.h. 3. I2C_IsReceptionCompleted must have been called to ensure that there are no pending requests and also to check if data byte has been received or not. 4. You must enable interrupts for <i>I2C interrupt driven</i> mode. 5. In <i>I2C Interrupt driven</i> mode, I2C_IT_Function must have been called in the Interrupt service routine.
Functions called	None
Postconditions	None
See also	None

Notes:

- The above function is for ***I2C Polling*** or ***I2C Interrupt driven*** mode.
- It is recommended to use a timeout protection when using this function.
- To terminate communication after receiving one byte using I2C_GetByte, you have to manage ACK bit and STOP generation as shown in the introduction.

Table 55. I2C_GetBuffer

Function Name	I2C_GetBuffer
Function Prototype	I2C_RxErrCode_t I2C_GetBuffer (unsigned char *PtrToBuffer, unsigned char NbOfBytes)
Behaviour Description	Receives number of data bytes and stores it in user defined area for I2C Polling mode. The data reception will stop if any error occurs during reception. The reception status will be returned.
Input Parameter 1	*PtrToBuffer Start address of the user buffer.
Input Parameter 2	NbOfBytes Number of bytes to be received.
Output Parameters	I2C_RX_AF If Acknowledge failure has occurred. I2C_RX_ARLO* If Arbitration lost is detected. I2C_RX_BERR* If misplaced start or stop condition detected. I2C_DATA_RX_OK If there is no error in reception.
Required Preconditions	1. I2C_Load_Address must have been called (If I2C is configured in the master receiver mode). 2. You must define I2C Polling mode in ST7lib_config.h.
Functions called	None
Postconditions	None
See also	I2C_GetBuffer (I2C Interrupt driven mode)

* This is applicable only in multimaster I2C.

Notes:

- The above function is only for **I2C Polling** mode.
- ACK bit is managed automatically inside this routine.
- STOP bit is set automatically inside this routine, before the last byte is read. So there is no need to call I2C_Generate_Stop after this.

Caution: The application can lose control if I2C is disabled when using this function in I2C Polling mode.

Table 56. I2C_GetBuffer

Function Name	I2C_GetBuffer
Function Prototype	Void I2C_GetBuffer (unsigned char *PtrToBuffer, unsigned char NbOfBytes)
Behaviour Description	Starts reception of data and stores it in user defined area for I2C Interrupt driven mode.
Input Parameter 1	*PtrToBuffer Start address of the user buffer.
Input Parameter 2	NbOfBytes Number of bytes to be received.
Output Parameters	None
Required Preconditions	<ol style="list-style-type: none"> 1. I2C_Load_Address must have been called (If I2C is configured in master receiver mode). 2. You must define I2C Interrupt driven mode in ST7lib_config.h. 3. I2C_IsReceptionCompleted must have been called to ensure that there are no pending requests. 4. You must enable interrupts for this mode. 5. In I2C Interrupt driven mode, I2C_IT_Function must have been called in the Interrupt service routine.
Functions called	None
Postconditions	I2C_IsReceptionCompleted must be called after this function to get the status of reception.
See also	I2C_GetBuffer (I2C Polling mode)

Notes:

- The above function is only for **I2C Interrupt driven** mode.
- ACK bit is managed automatically inside this routine.
- STOP bit is set automatically inside this routine, before the last byte is read. So there is no need to call I2C_Generate_Stop after this.

Caution:

- Take care not to access the string until reception completion.
- Any data received before calling this function is ignored.
- The data reception will stop if any error occurs during reception.
- In String reception, the NULL character must be taken into account.

Table 57. I2C_IsReceptionCompleted

Function Name	I2C_IsReceptionCompleted
Function Prototype	I2C_RxErrCode_t I2C_IsReceptionCompleted (void)
Behaviour Description	<p>For reception of a set of data in I2C Interrupt driven mode, the function checks for the completion of the reception or the occurrence of the error and returns the reception status.</p> <p>For reception of single byte of data in both I2C Polling and I2C Interrupt driven modes, it checks if a data byte is received and ready for processing. It returns I2C_RX_DATA_EMPTY until the data byte is received and returns the reception status when reception is complete.</p>
Input Parameters	None
Output Parameters	<p>I2C_RX_ARLO¹⁾ If Arbitration lost is detected.</p> <p>I2C_RX_BERR¹⁾ If misplaced start or stop condition is detected.</p> <p>I2C_RX_AF If Acknowledge failure has occurred.</p> <p>I2C_DATA_RX_OK If the data reception is completed without any error.</p> <p>I2C_RX_BUFFER_ONGOING²⁾ User buffer is not full.</p> <p>I2C_RX_DATA_EMPTY³⁾ If no data byte is received.</p>
Required Preconditions	None
Functions called	None
Postconditions	<p>1. For single byte reception, if the byte is received, then I2C_GetByte can be called after this function.</p> <p>2. I2C_Error_Clear can be called to clear the error and status flags, if required.</p>
See also	None

1) This is applicable only in multimaster I2C devices.

2) These Parameters are returned in **I2C Interrupt driven** mode only.

3) This Parameter is returned in case of single byte reception only, for both **I2C Polling** and **I2C Interrupt driven** modes

Notes:

- The above function is for **I2C Polling** or **I2C Interrupt driven** mode.
- In **I2C Polling** mode, this function is used in conjunction with I2C_GetByte only.
- If this function is called before any reception request is made, it will check for a single byte reception, and will return I2C_RX_DATA_EMPTY, until the first data byte is received, and

returns the reception status afterwards.

If a reception request is over, this function will return the error status of that request only once. If this function is called again (before making next reception request), then the function will check for single byte reception.

Table 58. I2C_IT_Function

Function Name	I2C_IT_Function
Function Prototype	Void I2C_IT_Function (void)
Behaviour Description	Transmits or receives data in I2C interrupt driven mode. You must call this function in the interrupt service routine.
Input Parameters	None
Output Parameters	None
Required Preconditions	You must have called transmission or reception function in I2C interrupt driven mode.
Functions called	None
Postconditions	None
See also	None

Note: You must use this function only inside the Interrupt service routine.

Caution: Special care must be taken, when you write your own code along with this function inside the interrupt service routine. As all **I2C interrupt driven** functions rely on this function, you are advised to call only this function in Interrupt service routine. Otherwise, data transfer synchronisation will be affected, which may lead to data loss or errors.

Table 59. I2C_Error_Clear

Function Name	I2C_Error_Clear
Function Prototype	Void I2C_Error_Clear (void)
Behaviour Description	Clear the error flags, if there are any.
Input Parameters	None
Output Parameters	None
Required Preconditions	Transmission or Reception should have taken place, before calling this function.
Functions called	None
Postconditions	None
See also	None

Note: You can call this function whenever the error flags are required to be cleared forcibly.

Caution: Do not call this function if a reception request is ongoing as it will corrupt the reception status by clearing all the flags and you will not receive any error status.

Table 60. I2C_ACK

Function Name	I2C_ACK
Function Prototype	Void I2C_ACK (I2C_ACK_Param ACK_Value)
Behaviour Description	Enables or disables acknowledge bit depending on the input.
Input Parameters	I2C_ACK_ENABLE Enables the acknowledge bit. I2C_ACK_DISABLE Disables the acknowledge bit.
Output Parameters	None
Required Preconditions	None
Functions called	None
Postconditions	None
See also	None

Table 61. I2C_Peripheral_Disable

Function Name	I2C_Peripheral_Disable
Function Prototype	Void I2C_Peripheral_Disable (void)
Behaviour Description	Disables the peripheral.
Input Parameters	None
Output Parameters	None
Required Preconditions	None
Functions called	None
Postconditions	You must call I2C_Init after this to enable peripheral.
See also	None

Note: When the peripheral is disabled, all I2C register bits except the stop bit and speed selection bits are cleared.

Table 62. I2C_Generate_Stop

Function Name	I2C_Generate_Stop
Function Prototype	Void I2C_Generate_Stop (void)
Behaviour Description	Generate stop condition.
Input Parameters	None
Output Parameters	None
Required Preconditions	Transmission or Reception must have taken place.
Functions called	None
Postconditions	None
See also	None

Note: In master mode, you must call this function to end data transfer.

Caution: In order to generate the non-acknowledge pulse after the last received data byte, the ACK bit must be cleared just before reading the second last byte. You must call I2C_GetBuffer before calling the I2C_Generate_Stop function or you have to manage non-acknowledge pulse.

Table 63. I2C_Generate_9Stops

Function Name	I2C_Generate_9Stops
Function Prototype	Void I2C_Generate_9Stops (void)
Behaviour Description	Generate 9 consecutive stop bits to re-synchronize I2C bus in a indefinite state.
Input Parameters	None
Output Parameters	None
Required Preconditions	When there are problems in communication and I2C bus is in indefinite state.
Functions called	None
Postconditions	You must call I2C_Init after this to start I2C operation.
See also	None

Note: This function is used only as a recovery measure. If the I2C slaves are powered separately or the MCU was reset during an I2C transmission, the I2C bus can be in an unknown state. In this case, this function can be used to re-synchronise the I2C. This routine must be called only one time after the MCU was reset.

Caution: The port register values of SDA and SCL pins changes if user calls this function. So, you must take the port register values into account.

EXAMPLE:

The following C program shows the uses of the I2C functions.

Program Description:

This program runs the following sequence for multimaster I2C (ST72F521 device) for **I2C Polling** and **I2C Interrupt driven** communication modes:

1. Transmits a single byte passed by the user and receives single byte of data in 7 bit addressing mode,
2. Transmits and receives the 10 bytes of data in 7 bit addressing mode.

The following modes are used for transmission and reception,

7 bit Tx - 7 bit master transmitter,

7 bit Rx - 7 bit master receiver,

You can select one pair of the following communication modes, for transmission and reception respectively:

I2C_POLLING_TX	-- For Transmission mode
I2C_POLLING_RX	-- For Reception mode
I2C_ITDRV_WITHOUTBUF_TX	-- For Transmission mode
I2C_ITDRV_WITHOUTBUF_RX	-- For Reception mode

/* You can use a timeout function to handle the fault in which the control will get stuck inside a loop. This function should have the Boolean return, i.e it should return TRUE if the expected wait Time is not elapsed and FALSE if it is elapsed.*/

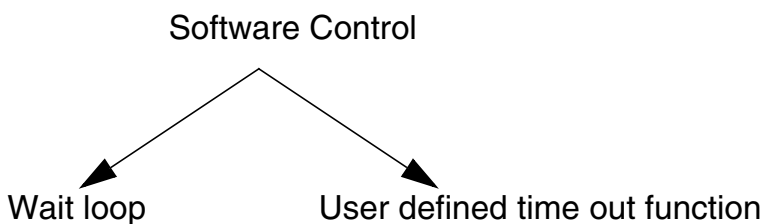

/*=====*/

The following variables are declared in main.h file.

main.h:

```
#ifndef MAIN
#define MAIN
```

```
void main(void);
void I2C_User_IT_Routine (void);
```



```

                                                                    /* Single byte data transmission */
I2C_PutByte (My_Data);
Timeoutcount = 0 ;
Temp1 = I2C_IsTransmitCompleted() ;
while ((User_Timeout_Function()) && (Temp1 != I2C_DATA_TX_OK))
{
    Temp1 = I2C_IsTransmitCompleted() ;
}
switch (Temp1)
{
    case I2C_TX_AF:
    case I2C_TX_ARLO:
    case I2C_TX_BERR:
        User_Function();
        break;
    default:
        User_Function();
        break;
}
                                                                    /* To check transmission status */
                                                                    /* Transmission of 10 data bytes from user buffer */
switch(I2C_PutBuffer (Buff, (unsigned char)10))
{
    case I2C_TX_AF:
    case I2C_TX_ARLO:
    case I2C_TX_BERR:
        User_Function();
        break;
    case I2C_DATA_TX_OK:
        break;
    default:
        User_Function();
        break;
}
                                                                    /* Error Management */
                                                                    /* None of the above condition is true */
                                                                    /* Transmission Stopped */
I2C_Generate_Stop ();
while (!(I2C_IsStopGen ()));
#endif
/*=====
Reception through 'Polling' mode
=====*/
/* Communication mode defined as POLLING_RX in ST7lib_config.h */
/* Single byte data reception */
#ifdef I2C_POLLING_RX
I2C_Generate_Start ();
while(!(I2C_IsTransmitCompleted()== I2C_START_OK));
I2C_Load_Address (Addr_Byte_Tx, I2C_RX_MODE);
Timeoutcount = 0 ;
Temp1 = I2C_IsTransmitCompleted() ;
while ((User_Timeout_Function()) && (Temp1 != I2C_ADD_TX_OK))
{
    Temp1 = I2C_IsTransmitCompleted() ;
}
switch (Temp1)
{
    case I2C_TX_AF:
        User_Function();
}
                                                                    /* To check reception status */

```

```

        break;
    default:
        break;
}
Timeoutcount = 0 ;
Temp2 = I2C_IsReceptionCompleted() ;
while ((User_Timeout_Function()) && (Temp2 == I2C_RX_DATA_EMPTY))
{
    Temp2 = I2C_IsReceptionCompleted() ;
}
/* Waits for data byte reception */
if (User_Timeout_Function())
{
    switch (Temp2)
    {
        case I2C_RX_ARLO:
        case I2C_RX_BERR:
            Rx_Data = I2C_GetByte();          /* Corrupted data byte received */
            User_Function();                  /* Error Management */
            break;
        case I2C_DATA_RX_OK:                  /* Reception successful */
            Rx_Data = I2C_GetByte();
            break;
        default:                               /* None of the above condition is true */
            User_Function ();
            break;
    }
}
else
{
    /* Handle time out as Transmitter/Receiver is having some problem */
}
/* Reception of a set of data */
switch(I2C_GetBuffer (Buff_Test, (unsigned char)10))
{
    case I2C_RX_ARLO:
    case I2C_RX_BERR:
        User_Function();                    /* Error Management */
        break;
    case I2C_DATA_RX_OK:
        break;
    default:                                  /* None of the above condition is met */
        User_Function ();
        break;
}
#endif

/*=====
Transmission through 'Interrupt driven without buffer' mode
=====*/
/* Communication mode defined as ITDRV_WITHOUTBUF_TX in
ST7lib_config.h */
/* Single byte transmission */
#ifdef I2C_ITDRV_WITHOUTBUF_TX
if ((I2C_IsTransmitCompleted()) == I2C_DATA_TX_OK)

```

```

/* Ensure that there are no pending requests */
{
    I2C_Generate_Start ();
    while(! (I2C_IsTransmitCompleted())== I2C_START_OK);
    I2C_Load_Address (Addr_Byte_Tx, I2C_TX_MODE);
    Timeoutcount = 0 ;
    Temp1 = I2C_IsTransmitCompleted() ;
    while ((User_Timeout_Function()) && ( Temp1 != I2C_ADD_TX_OK))
    {
        Temp1 = I2C_IsTransmitCompleted() ;
    }
    switch (Temp1) /* To check transmission status */
    {
        case I2C_TX_AF:
            User_Function();
            break;
        default:
            break;
    }
    I2C_PutByte (My_Data) ; /* User data is copied to global variable */
    /* Here, user can perform other tasks or operations except
    transmission till the time transmission is complete, after which
    user can perform transmission again */
    switch (I2C_IsTransmitCompleted()) /* To check transmission status */
    {
        case I2C_TX_AF:
        case I2C_TX_ARLO:
        case I2C_TX_BERR:
            User_Function(); /* Error Management */
            break;
        case I2C_DATA_TX_OK:
            break;
        default: /* If none of the above condition is true */
            User_Function();
            break;
    }
    /* Transmission of set of data from the user buffer */
    I2C_PutBuffer (Buff, (unsigned char)10);
    /* User pointer is copied to global pointer */
    /* Here, user can perform other tasks or operations except
    transmission till the time transmission is complete, after which
    user can perform transmission again */
    Timeoutcount = 0 ;
    Temp1 = I2C_IsTransmitCompleted() ;
    while ( (User_Timeout_Function())&& ((Temp1) == I2C_TX_BUFFER_ONGOING))
    {
        Temp1 = I2C_IsTransmitCompleted() ;
    } /* To be sure that the communication by this
    point has been completed */
    if (User_Timeout_Function())
    {
        switch(Temp1)
        {
            case I2C_TX_AF:
            case I2C_TX_BERR:

```

```

        User_Function();                /* Error Management */
        break;
    case I2C_DATA_TX_OK:                /* Transmission successful */
        break;
    default:                            /* If none of the above condition is true */
        User_Function();
        break;
    }
}
I2C_Generate_Stop ();
while (!(I2C_IsStopGen ()));
}
#endif

/*=====
Reception through 'Interrupt driven without buffer' mode
=====*/
/* Communication mode defined as ITDRV_WITHOUTBUF_RX in
ST7lib_config.h */
/* Single byte reception */
#ifdef I2C_ITDRV_WITHOUTBUF_RX
I2C_Generate_Start ();
while (!(I2C_IsTransmitCompleted()) == I2C_START_OK));
I2C_Load_Address (Addr_Byte_Tx, I2C_RX_MODE);
Timeoutcount = 0 ;
Temp1 = I2C_IsTransmitCompleted() ;
while ((User_Timeout_Function()) && ( Temp1 != I2C_ADD_TX_OK))
{
    Temp1 = I2C_IsTransmitCompleted() ;
}
switch (Temp1)                        /* To check address transmission status */
{
    case I2C_TX_AF:
        User_Function();
        break;
    default:
        break;
}
Timeoutcount = 0 ;
Temp2 = I2C_IsReceptionCompleted() ;
while ((User_Timeout_Function()) && ((Temp2) == I2C_RX_DATA_EMPTY) )
{
    Temp2 = I2C_IsReceptionCompleted() ;
}
/* Waits for data byte reception */
if (User_Timeout_Function())
{
    switch (Temp2)
    {
        case I2C_RX_ARLO:
        case I2C_RX_BERR:
            Rx_Data =I2C_GetByte ();
            User_Function();
            break;
        case I2C_DATA_RX_OK:

```

```

        Rx_Data =I2C_GetByte ();
        break;
    default:                                /* None of the above condition is true */
        User_Function ();
        break;
    }
}
/* Reception of set of data in the user buffer */
I2C_GetBuffer (Buff_Test, (unsigned char) 10);    /* Any data received before calling
                                                    this function is ignored */

/* Here, user can perform other tasks or operations except reception till
the time reception is complete, after which user can perform reception
again */

Timeoutcount = 0 ;
Temp2 = I2C_IsReceptionCompleted() ;
while ((User_Timeout_Function()) && ((Temp2) == I2C_RX_BUFFER_ONGOING))
{
    Temp2 = I2C_IsReceptionCompleted() ;
}
/* To be sure that the communication by this point has been completed */
if (User_Timeout_Function())
{
    switch (Temp1)
    {
        case I2C_RX_BERR:
        case I2C_RX_BUFFER_ONGOING:
            User_Function();                    /* Error Management */
            break;
        case I2C_DATA_RX_OK:                    /* Reception successful */
            break;
        default:                                /* If none of the above condition is true */
            break;
    }
}
#endif
}

/*-----
ROUTINE NAME : I2C_User_IT_Routine
INPUT      : None
OUTPUT     : None
DESCRIPTION : Control comes into this routine when an interrupt is generated.
              User can use the I2C interrupt service routine function or he
              can write his own code inside this routine at his own risk. The
              data transfer synchronisation may be affected if user includes
              his own code along with I2C ISR function.
COMMENTS   : None
-----*/
#ifdef _HIWARE_                                /* Test for HIWARE Compiler */
#pragma TRAP_PROC SAVE_REGS                    /* Additional registers will be saved */
#else
#ifdef _COSMIC_                                /* Test for Cosmic Compiler */
@interrupt                                    /* Cosmic interrupt handling */

```

Function Descriptions

```
#else
#error "Unsupported Compiler!"           /* Compiler Defines not found! */
#endif
#endif

void I2C_User_IT_Routine (void)
{
    I2C_IT_Function () ;                 /* I2C Interrupt service routine */
}

/*-----
                USER FUNCTIONS
-----*/

BOOL User_Timeout_Function(void)
{
    while(Timeoutcount < 50000)
    {
        Timeoutcount++ ;
        return (TRUE) ;                 /* Time-out not elapsed */
    }
    return (FALSE) ;                   /* Time-out elapsed */
}

void User_Function(void)
{
    I2C_Error_Clear () ;               /* Clears error and status flags */
}
```

9.1.5 I2C SLAVE

This section contains the description of all the functions for I2C slave. You can select either of the Transmission/Reception modes of I2C implemented inside the library by using the corresponding #define statement.

Figure 4. General Flow Chart For I2C -Slave (Polling Mode)

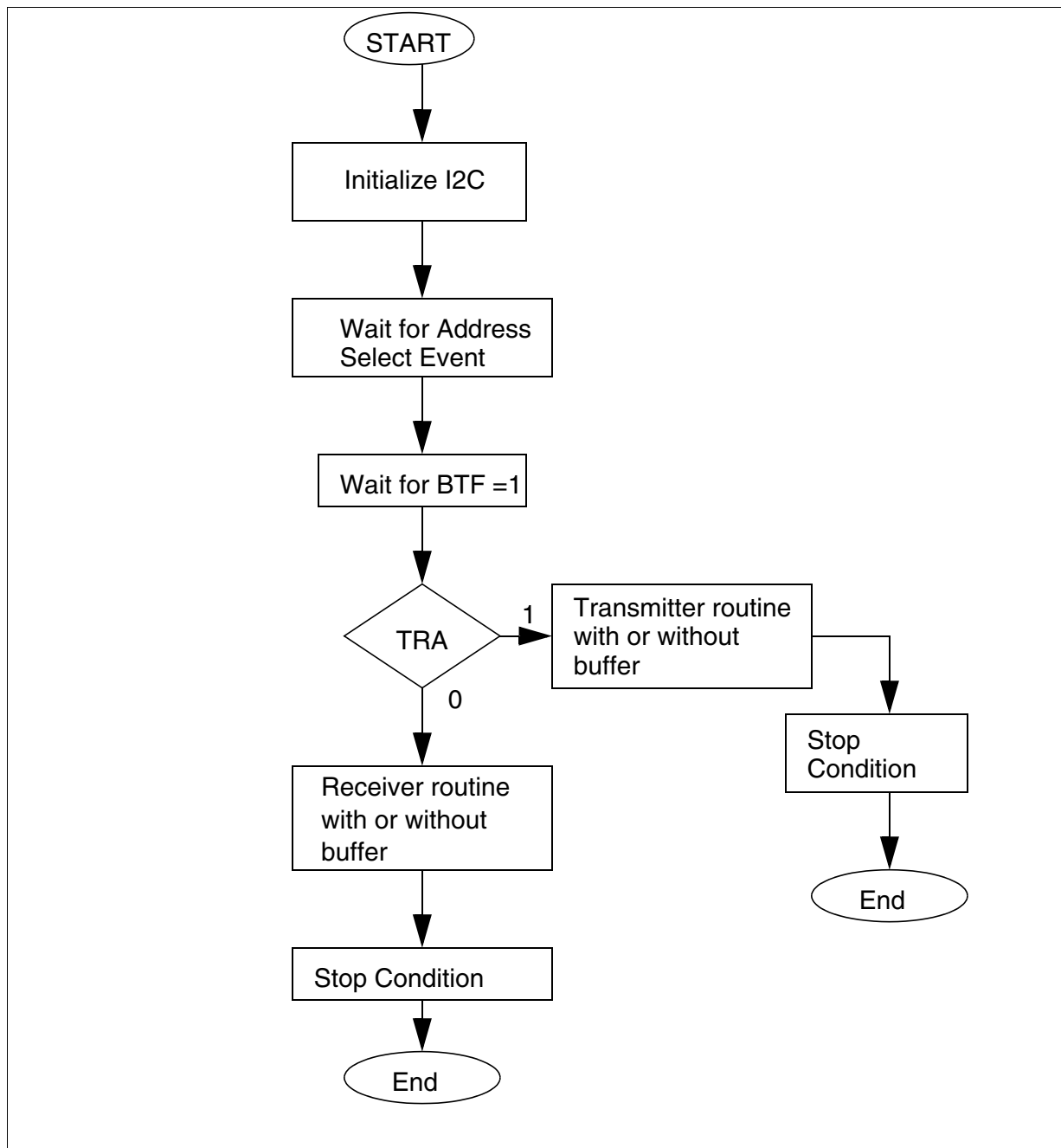

Note: This is a general flow part. Error management is not shown here for the purpose of simplicity.

Table 64. I2C Slave Functions:

Function Name	I2Cs_Init
Function Prototype	Void I2Cs_Init(I2Cs_Control_Param InitParam,unsigned char I2Cs_OAR1Value,unsigned char I2Cs_OAR2Value)
Behaviour Description	By default, Acknowledge and General Call are disabled. You can change the default configuration by selecting input parameters given below. You can pass one or more parameters by logically ORing them. I2C peripheral is also enabled.
Input Parameter 1	I2Cs_DEFAULT_PARAM Load I2C control registers with default value I2Cs_ENABLE_ACK Enables acknowledge. I2Cs_ENABLE_ENGC Enables General Call
Input Parameter 2	I2Cs_OAR1Value Load the OAR1 address.
Input Parameter 3	I2Cs_OAR2Value Load 10 bit higher address bits and also sets FRi bits according to the value of Fcpu.
Output Parameters	None
Required Preconditions	I/O port should be configured correctly.
Functions called	None
Postconditions	None
See also	None

Notes:

- For ST72F63B device there is only one address register I2COAR (It does not support 10 bit addressing). Here I2COAR will get the value of I2Cs_OAR1Value and the value of I2Cs_OAR2Value will be neglected.
- If single master I2C device is selected, I2C will remain idle as in this case I2C can not behave as slave.
- When slave is in the interrupt mode. That is,
if #ifdef I2C_ITDRV_WITHOUTBUF_TX Or,
ifdef I2C_ITDRV_WITHOUTBUF_RX are defined then ITE bit is also set in control register automatically. There is no separate parameter for enabling the ITE bit.

Caution:

- If ITE bit is forcibly modified in the User routine using the hardware register then the behaviour of the I2C slave library is unpredictable.
- If you are using the I2C as both transmitter and receiver, then both should be configured in the same mode (Polling/ Interrupt driven).

Table 65. I2Cs_GetCommMode

Function Name	I2Cs_GetCommMode
Function Prototype	I2Cs_Mode I2Cs_GetCommMode(void)
Behaviour Description	It will return I2Cs_DEFAULT mode before first BTF event and, will return I2Cs_TX_MODE or I2Cs_RX_MODE mode after that.
Input Parameters	None
Output Parameters	I2Cs_TX_MODE Slave is transmitter I2Cs_RX_MODE Slave is receiver I2Cs_DEFAULT The default mode
Required Preconditions	I2Cs_IsReceptionCompleted
Functions called	None
Postconditions	None
See also	None

Notes:

1. In I2Cs_DEFAULT mode, you should use I2Cs_IsReceptionCompleted to detect the start condition. As by default the slave is considered as a receiver.
2. You can directly call this function to get the mode of communication after getting Address matched condition irrespective of whether it is 7-bit or 10-bit address detection.
3. If you are calling this function in a loop for detecting the mode of communication then control will not come out of this loop till the first BTF condition occurs. So if BTF is never set then the program will lose control in the above loop. In this case you can use note (1) to tackle this problem to detect the error condition inside the loop.

Table 66. I2Cs_PutBuffer

Function Name	I2Cs_PutBuffer
Function Prototype	I2Cs_ErrCode_t I2Cs_PutBuffer(unsigned char *PtrToBuffer, unsigned char MaxSize)
Behaviour Description	Transmits data buffer from the user defined area for I2C_POLLING_TX mode. The data transmission will discontinue, if any error occurs during transmission and the error status will be returned.
Input Parameter 1	*PtrToBuffer Start address of the user buffer
Input Parameter 2	MaxSize The maximum no of bytes to be transmitted
Output Parameters	<p>I2Cs_BERR An bus error has occurred</p> <p>I2Cs_ADDRESS_DETECTED If the device address is matched</p> <p>I2Cs_GENERAL_CALL If the general call is detected</p> <p>I2Cs_TX_DATA_OK If there is no error in data transmission and stop is detected correctly.</p> <p>I2Cs_OVERFLOW_TX If transmission has taken place correctly but the some byte transmitted will be dummy bytes (0xFF). As the no of bytes transmitted are more than the maximum size of the buffer.</p>
Required Preconditions	<ol style="list-style-type: none"> 1. You must define I2C_POLLING_TX mode in ST7lib_config.h 2. I2C communication mode must be detected through the I2Cs_GetCommMode
Functions called	None
Postconditions	None
See also	I2Cs_GetBuffer, I2Cs_PutBuffer (<i>I2C Interrupt driven mode</i>)

* The maximum size of the buffer is under user control.

Notes:

- This function is only for **I2C_POLLING_TX** mode.
- Here, an Acknowledge Failure (I2Cs_TX_AF) error is not returned as it is handled internally.

Caution: Control can be lost if I2C is disabled while using this function for I2C Polling mode.

Overflow condition: The overflow bytes neglected through dummy bytes (0xFF).

Table 67. I2Cs_PutBuffer ‘I2C interrupt driven’

Function Name	I2Cs_PutBuffer
Function Prototype	Void I2Cs_PutBuffer(unsigned char *PtrToBuffer, unsigned char MaxSize)
Behaviour Description	Starts transmission of data from the user defined area by initializing the transmission buffer for I2C_ITDRV_WITHOUTBUF_TX mode
Input Parameter 1	*PtrToBuffer Start address of the user buffer
Input Parameter 2	MaxSize Size of the buffer
Output Parameters	None
Required Preconditions	1. You must define I2C_ITDRV_WITHOUTBUF_TX mode in ST7lib_config.h 2. I2C communication mode must be detected through the I2Cs_GetCommMode
Functions called	None
Postconditions	I2Cs_IsTransmitCompleted should be called to know the current status of transmission
See also	I2Cs_PutBuffer (I2C Polling mode)

* The maximum size of the buffer is under user control.

Note: The above function is only for I2C_ITDRV_WITHOUTBUF_TX mode.

Caution:

– Any data transmitted before using this function will be neglected through dummy byte

Overflow condition: The overflow bytes are neglected through dummy bytes.

Table 68. I2Cs_PutByte

Function Name	I2Cs_PutByte
Function Prototype	Void I2Cs_PutByte (unsigned char Tx_Byte)
Behaviour Description	Transmits single byte on the I2C bus
Input Parameter	Tx_Byte The byte to be transmit on the I2C bus
Output Parameters	None
Required Preconditions	1) I2Cs_GetCommMode must have been called before transmitting first byte to check whether the I2Cs_TX_MODE is selected or not 2) Transmission of previous data has been taken successfully, which should be checked through the I2Cs_IsTransmitCompleted
Functions called	None
Postconditions	None
See also	I2Cs_GetByte

Table 69. I2Cs_IsTransmitCompleted

Function Name	I2Cs_IsTransmitCompleted
Function Prototype	I2Cs_ErrCode_t I2Cs_IsTransmitCompleted (void)
Behaviour Description	Returns the current status of I2C in transmission mode for Single Byte (Polling and Interrupt both), and Interrupt mode Buffer I2C communication
Input Parameters	None
Output Parameters	<p>Common:</p> <p>I2Cs_TX_AF If Acknowledge failure condition is detected. Also the SCL and SDA lines are released inside the function</p> <p>I2Cs_BERR If misplaced start or stop condition detected</p> <p>I2Cs_ADDRESS_DETECTED If Address matched condition is detected</p> <p>I2Cs_GENERAL_CALL If the general call is detected</p> <p>I2Cs_DEFAULT_STATUS No communication event has occurred</p> <p>Byte Specific:</p> <p>I2Cs_TX_DATA_OK Transmission of current byte has taken place successfully</p> <p>I2Cs_STOP_DETECTED If the stop condition is detected</p> <p>Buffer Specific:</p> <p>I2Cs_BUFF_TX_ONGOING If the transmission of the buffer is ongoing successfully</p> <p>I2Cs_TX_DATA_OK Transmission has taken place successfully and Stop condition is detected</p> <p>I2Cs_OVERFLOW_TX Transmission has taken place successfully and stop is detected correctly. But overflow condition has occurred</p>
Required Preconditions	Check through I2Cs_GetCommMode If I2Cs_TX_MODE is selected or not
Functions called	None
Postconditions	None
See also	I2Cs_IsReceptionCompleted

Notes:

- The above function is for both polling and Interrupt driven mode. But in **I2C_POLLING_TX** mode, this function is used in conjunction with I2Cs_PutByte only.

- SCL and SDA lines are released in this function in case of Acknowledge failure and communication proceeds according to the I2C protocol. This function should be called again to detect the next event (START / STOP).

Table 70. I2Cs_GetBuffer

Function Name	I2Cs_GetBuffer
Function Prototype	I2Cs_ErrCode_t I2Cs_GetBuffer(unsigned char *PtrToBuffer, unsigned char MaxSize)
Behaviour Description	Receives data bytes in I2C_POLLING_RX mode and stores in the buffer, whose start address is passed as pointer. The data reception will discontinue, if any error occurs during reception and the error status will be returned .
Input Parameter 1	*PtrToBuffer Start address of the user buffer
Input Parameter 2	MaxSize Maximum size of the buffer
Output Parameters	I2Cs_BERR Bus error is detected I2Cs_ADDRESS_DETECTED If address matched condition is detected I2Cs_GENERAL_CALL If general call is detected I2Cs_RX_DATA_OK If there is no error in data transmission and stop condition is detected correctly I2Cs_OVERFLOW_RX If reception has taken place correctly but overflow condition has occurred
Required Preconditions	1. You must define I2C_POLLING_RX mode in ST7lib_config.h. 2. I2C communication must be detected through the I2Cs_GetCommMode.
Functions called	None
Postconditions	None
See also	I2Cs_GetBuffer (I2C Interrupt driven mode), I2Cs_PutBuffer

Notes:

- The above function is only for **I2C_POLLING_RX** mode.
- Control from this function comes only after receiving a STOP or any Error condition.

Caution: You can lose the control if I2C is disabled while using this function.

Table 71. I2Cs_GetBuffer *'I2C Interrupt driven'*

Function Name	I2Cs_GetBuffer
Function Prototype	Void I2Cs_GetBuffer (unsigned char *PtrToBuffer, unsigned char MaxSize)
Behaviour Description	Starts reception of data from the user defined area by initializing the reception buffer in the I2C_ITDRV_WITHOUTBUF_RX mode.
Input Parameter 1	*PtrToBuffer Start address of the user buffer
Input Parameter 2	MaxSize Size of the buffer
Output Parameters	None
Required Preconditions	1. You must define I2C_ITDRV_WITHOUTBUF_RX mode in ST7lib_config.h 2. I2Cs_RX_MODE must be detected through I2Cs_GetCommMode before calling this function
Functions called	The status of the reception should be checked through I2Cs_IsReceptionCompleted function
Postconditions	None
See also	I2Cs_GetBuffer (<i>I2C Polling</i> mode)

Note: The above function is only for **I2C_ITDRV_WITHOUTBUF_RX** mode.

Table 72. I2Cs_GetByte

Function Name	I2Cs_GetByte
Function Prototype	Unsigned char I2Cs_GetByte(void)
Behaviour Description	Returns received byte from I2C bus
Input Parameters	None
Output Parameters	Received data byte
Required Preconditions	I2Cs_GetCommMode must have been called before receiving first byte or reception of previous data has taken successfully, which should be detected through I2Cs_IsReceptionCompleted.
Functions called	None
Postconditions	None
See also	I2Cs_PutByte

Table 73. I2Cs_IsReceptionCompleted

Function Name	I2Cs_IsReceptionCompleted
Function Prototype	I2Cs_ErrCode_t I2Cs_IsReceptionCompleted(void)
Behaviour Description	Returns the current status of I2C in reception mode for Single Byte (Polling and Interrupt both), and Interrupt mode Buffer I2C communication
Input Parameters	None
Output Parameters	<p>Common</p> <p>I2Cs_BERR If bus error is detected</p> <p>I2Cs_ADDRESS_DETECTED If the start condition is detected</p> <p>I2Cs_GENERAL_CALL If general call is detected</p> <p>I2Cs_EMPTY The first byte has not received yet</p> <p>I2Cs_DEFAULT_STATUS No Communication event has occurred after receiving first byte</p> <p>Byte Specific</p> <p>I2Cs_RX_DATA_OK Reception of the current byte has taken place successfully</p> <p>I2Cs_STOP_DETECTED If the stop condition is detected</p> <p>BufferSpecific</p> <p>I2Cs_BUFF_RX_ONGOING If the reception is ongoing successfully</p> <p>I2Cs_RX_DATA_OK Reception has taken place successfully and stop is detected correctly</p> <p>I2Cs_OVERFLOW_RX Reception has taken place successfully and stop is detected correctly. But overflow condition has occurred.</p>
Required Preconditions	None
Functions called	None
Postconditions	None
See also	I2Cs_IsTransmitCompleted

Notes:

- The above function is for both Polling and Interrupt driven Mode. But in I2C_POLLING_RX it is used only with I2Cs_GetByte.

– If this function is called before any reception request is made then it will return I2C_EMPTY until the first data byte is received, and returns the reception status thereafter. If a reception request is over, this function will return the error status of that request only once.

Table 74. I2Cs_ErrorClear

Function Name	I2Cs_ErrorClear
Function Prototype	Void I2Cs_ErrorClear (void)
Behaviour Description	Clears the error flags, if there are any
Input Parameters	None
Output Parameters	None
Required Preconditions	None
Functions called	None
Postconditions	None
See also	None

Note: You can call this function, whenever the error flags are required to be cleared forcibly.

Caution: Do not call this function if a reception request iOs ongoing as it will corrupt the reception status by clearing all the flags and you will not receive the error status.

Table 75. I2Cs_PeripheralDisable

Function Name	I2Cs_PeripheralDisable
Function Prototype	Void I2Cs_PeripheralDisable (void)
Behaviour Description	Disables the peripheral
Input Parameters	None
Output Parameters	None
Required Preconditions	None
Functions called	None
Postconditions	You must call I2Cs_Init after this to reconfigure the peripheral.
See also	None

Note: When you disable the peripheral, all registers are also cleared except the Stop bit and address registers. So to reinitiate the communication, the I2C peripheral needs to be initialized again.

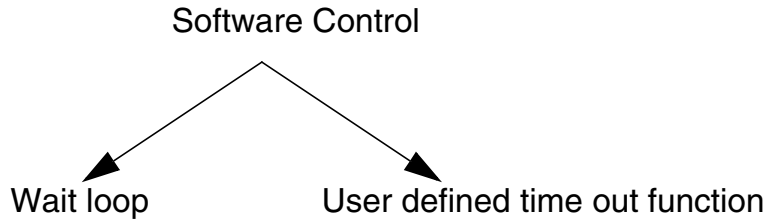

```
/*=====*/
```

The following variables are declared in main.h file.

main.h:

```
#ifndef MAIN
#define MAIN
```

```
void I2Cs_User_IT_Routine(void);
void main(void);
BOOL Time_Out(void); /* Prototypes of user function */
void User_Function(void);
unsigned int count=0;
```

```
#endif
```

```
/*=====*/
```

```
/* Program Start */
```

```
/* This example code explains the usage of I2C slave in the transmitter
and receiver mode. First the slave is configured as a transmitter and it
transmits 10 bytes of data from the user buffer. Then it is configured as a
receiver and it reads the same 10 bytes of data and they are compared.
In case of any mismatch control gets struck in a loop*/
```

```
#include "ST7lib_config.h"
#include "main.h"
unsigned char Buff_In[9]= {0x00};
unsigned char Buff_Out[]={1,2,3,4,5,6,7,8,9};
```

```
void main(void) /* This is for polling & interrupt driven */
{
```

```
    unsigned char OAR1Value = 0x30;
    unsigned char OAR2Value = 0x00;
    unsigned char maxsize = 9, single_byte = 0x05, first_byte = 0x00;
    BOOL TX_STATUS = TRUE;
    I2Cs_ErrCode_t Error_Status = I2Cs_DEFAULT_STATUS;
    I2Cs_Mode Comm_Mode = I2Cs_DEFAULT;
    unsigned int i;
```

```
    EnableInterrupts
```

```
    I2Cs_Init(((unsigned char) I2Cs_ENABLE_ACK) | ((unsigned char)
        I2Cs_ENABLE_ENGC), OAR1Value, OAR2Value); /* ACK bit is set */
```

```

Error_Status=I2Cs_IsReceptionCompleted();
while((!Time_Out()) && (Error_Status != I2Cs_ADDRESS_DETECTED))
/* Time_out() is bring before to remove side-effect error */
{
    Error_Status=I2Cs_IsReceptionCompleted();
}

Comm_Mode=I2Cs_GetCommMode();
while(Comm_Mode == I2Cs_DEFAULT)
{
    Comm_Mode=I2Cs_GetCommMode();          /* checking for communication mode */
}

/***** Polling Mode Transmission *****/
if(Comm_Mode == I2Cs_TX_MODE)              /* transmitter mode */
{
    /* SINGLE BYTE TRANSMISSION */
    I2Cs_PutByte(single_byte);
    Error_Status=I2Cs_IsTransmitCompleted();
    while((!Time_Out())) && (Error_Status != I2Cs_TX_DATA_OK)
    {
        Error_Status=I2Cs_IsTransmitCompleted();
    }
    switch( Error_Status)
    {
        case I2Cs_TX_AF:
        case I2Cs_BERR:
        case I2Cs_DEFAULT_STATUS:
        case I2Cs_STOP_DETECTED:
        case I2Cs_GENERAL_CALL:
        case I2Cs_ADDRESS_DETECTED:
            User_Function();
            break;
        default:
            User_Function();
            break;
    }
}

/***** BUFFER TRANSMISSION *****/
/***** POLLING MODE *****/
#ifdef I2C_POLLING_TX
Error_Status = I2Cs_PutBuffer(Buff_Out,maxsize);
switch(Error_Status)
{
    case I2Cs_TX_DATA_OK:
    case I2Cs_OVERFLOW_TX:
        break;

    case I2Cs_BERR:
    case I2Cs_ADDRESS_DETECTED:
    case I2Cs_GENERAL_CALL:
        User_Function();
        break;
    default:
        User_Function();
}

```

Function Descriptions

```
                break;
            }
        #endif

/***** end of polling mode *****/
/***** INTERRUPT DRIVEN MODE *****/
    #ifdef I2C_ITDRV_WITHOUTBUF_TX

        I2Cs_PutBuffer(Buff_Out,maxsize);
        Error_Status=I2Cs_IsTransmitCompleted();

        while((!(Time_Out())) && ((Error_Status != I2Cs_TX_DATA_OK) && (Error_Status
!= I2Cs_OVERFLOW_TX)))
        {
            Error_Status=I2Cs_IsTransmitCompleted();
        }

        switch( Error_Status)
        {
            case I2Cs_BUFF_TX_ONGOING:
                Error_Status=I2Cs_IsTransmitCompleted();
                while((Error_Status != I2Cs_TX_DATA_OK) && (Error_Status !=
I2Cs_OVERFLOW_TX))
                {
                    Error_Status=I2Cs_IsTransmitCompleted();
                }
                break;

            case I2Cs_TX_DATA_OK:
            case I2Cs_OVERFLOW_TX:
                break;

            case I2Cs_TX_AF:
            case I2Cs_BERR:
            case I2Cs_GENERAL_CALL:
            case I2Cs_ADDRESS_DETECTED:
            case I2Cs_DEFAULT_STATUS:
                User_Function();
                break;
            default:
                User_Function();
                break;
        }
    #endif
/*****END OF INTERRUPT DRIVEN MODE *****/
}

/*****
/***** RECEIVER ROUTINE *****/

        Error_Status=I2Cs_IsReceptionCompleted();
        while((!(Time_Out()))&& ((Error_Status != I2Cs_ADDRESS_DETECTED) && (Error_Status
!= I2Cs_GENERAL_CALL)))
        {
            Error_Status=I2Cs_IsReceptionCompleted();
```

```

}
Comm_Mode=I2Cs_GetCommMode();
while((Comm_Mode == I2Cs_DEFAULT))
{
    Comm_Mode=I2Cs_GetCommMode();
}
if(Comm_Mode == I2Cs_RX_MODE) /* POLLING AND INTERRUPT DRIVEN RECEIVER */
{
    Error_Status=I2Cs_IsReceptionCompleted();
    /* ONE BYTE RECEPTION */

    while((!(Time_Out())) && (Error_Status != I2Cs_RX_DATA_OK))
    {
        Error_Status=I2Cs_IsReceptionCompleted();
    }
    switch(Error_Status)
    {
        case I2Cs_RX_DATA_OK:
            first_byte=I2Cs_GetByte();
            break;
        case I2Cs_STOP_DETECTED:
        case I2Cs_BERR:
        case I2Cs_GENERAL_CALL:
        case I2Cs_ADDRESS_DETECTED:
        case I2Cs_EMPTY:
        case I2Cs_DEFAULT_STATUS:
            User_Function();
            break;
        default:
            User_Function();
            break;
    }
}

/*****BUFFER RECEPTION *****/
/*****POLLING MODE *****/
#ifdef I2C_POLLING_RX
Error_Status=I2Cs_GetBuffer(Buff_In,maxsize);
switch(Error_Status)
{
    case I2Cs_RX_DATA_OK:
    case I2Cs_OVERFLOW_RX:
        break;
    case I2Cs_BERR:
    case I2Cs_ADDRESS_DETECTED:
    case I2Cs_GENERAL_CALL:
        User_Function();
        break;
    default:
        User_Function();
        break;
}
#endif
/***** end of polling mode *****/

/*****INTERRUPT DRIVEN MODE *****/

```

```
#ifdef I2C_ITDRV_WITHOUTBUF_RX
Error_Status=I2Cs_IsReceptionCompleted();
while((!(Time_Out())) && (Error_Status != I2Cs_RX_DATA_OK))
{
    Error_Status=I2Cs_IsReceptionCompleted();
}

switch(Error_Status)
{
    case I2Cs_BUFF_RX_ONGOING:
    case I2Cs_OVERFLOW_RX:
    case I2Cs_BERR:
    case I2Cs_EMPTY:
    case I2Cs_ADDRESS_DETECTED:
    case I2Cs_GENERAL_CALL:
        User_Function();
        break;
    case I2Cs_RX_DATA_OK:
        break;
    default:
        User_Function();
        break;
}

I2Cs_GetBuffer (Buff_In,maxsize);

Error_Status=I2Cs_IsReceptionCompleted();
while((!(Time_Out())) && (Error_Status != I2Cs_RX_DATA_OK))
{
    Error_Status=I2Cs_IsReceptionCompleted();
}

switch(Error_Status)
{
    case I2Cs_BUFF_RX_ONGOING:
    case I2Cs_OVERFLOW_RX:
    case I2Cs_BERR:
    case I2Cs_EMPTY:
    case I2Cs_ADDRESS_DETECTED:
    case I2Cs_GENERAL_CALL:
        User_Function();
        break;
    case I2Cs_RX_DATA_OK:
        break;
    default:
        User_Function();
        break;
}
#endif

/*****END OF INTERRUPT DRIVEN MODE *****/
} /* END OF RECEIVER ROUTINE */
```

```

/*****
/**** COMPARE THE TRANSMITTED AND RECEIVED BYTES *****/

    while (single_byte != first_byte);
    for (i=0;i<maxsize;i++)
    { //add braces
        while(Buff_Out[i] != Buff_In[i]);
    }
/*****
    while(1);
} /* End of the main */

/*-----
ROUTINE NAME : User_IT_Routine
INPUT      : None
OUTPUT     : None
DESCRIPTION : Control comes into this routine when an interrupt is generated.
             User can use the I2C interrupt service routine function for
             slave or he can write his own code inside this routine at his
             own risk. The data transfer synchronisation may be affected if
             user includes his own code along with I2C ISR function.
COMMENTS   : None
-----*/

#ifdef _HIWARE_                                     /* Test for HIWARE Compiler */
#pragma TRAP_PROC SAVE_REGS                       /* Additional registers will be saved */
#else
#ifdef _COSMIC_                                     /* Test for Cosmic Compiler */
@interrupt                                       /* Cosmic interrupt handling */
#else
#error "Unsupported Compiler!"                 /* Compiler Defines not found! */
#endif
#endif

void I2Cs_User_IT_Routine (void)
{
    I2Cs_ITFunction() ;
}
/*****
    Time_Out Function
*****/
BOOL Time_Out(void)
{
    while(count < 5000)
    {
        count++ ;
        return (FALSE);                          /* Time-out not elapsed */
    }
    return (TRUE) ;                               /* Time-out elapsed */
}

void User_Function(void)
{
    I2Cs_ErrorClear() ;
    /* user can include his code here */
}

```

9.1.6 16-bit TIMER (TIMER)

This software library for the 16-bit TIMER can be used for both Timer A and Timer B. To use any of the timers you have to replace x by A or B.

Function Name	TIMERx_Init
Function Prototype	Void TIMERx_Init(Typ_Timer_InitParameter InitValue)
Behaviour Description	Initializes the timer control registers and status register to their default values. Timer clock can be selected as Fcpu/2, Fcpu/8 and external clock can also be set. Default value of clock is Fcpu/4.
Input Parameters	<p>TIMER_FCPU_2 Timer clock is set to Fcpu/2</p> <p>TIMER_FCPU_4 Timer clock is set to Fcpu/4</p> <p>TIMER_FCPU_8 Timer clock is set to Fcpu/8</p> <p>TIMER_EXCLK_F Timer counter will be triggered through the falling (trailing) edge of external clock.</p> <p>TIMER_EXCLK_R Timer counter will be triggered through the rising (leading) edge of external clock.</p> <p>TIMER_DEFAULT Reset value (Default value)</p>
Output Parameters	None
Required Preconditions	None
Functions called	None
Postconditions	Timer clock is configured correctly.
See also	None

Note: Timer B available in ST72F521, ST72F264, ST72325 and ST7232A.

Table 77. TIMERx_IT_Enable

Function Name	TIMERx_IT_Enable
Function Prototype	Void TIMERx_IT_Enable(Typ_Timer_EITParameter EITValue)
Behaviour Description	Enables the timer interrupts. One or more input parameters can be passed by logically ORing them together.
Input Parameters	TIMER_OCMP_IT_ENABLE Enables the output compare interrupts TIMER_ICAP_IT_ENABLE ¹⁾ Enables the input capture interrupts TIMER_OVF_IT_ENABLE Enables the timer overflow interrupt
Output Parameters	None
Required Preconditions	None
Functions called	None
Postconditions	Interrupts are enabled for a particular flag. You also have to enable the interrupt with instruction 'rim'.
See also	TIMERx_IT_Disable

1) Not available in ST72F65.

Note: Timer B available in ST72F521, ST72F264, ST72325 and ST7232A.

Table 78. TIMERx_IT_Disable

Function Name	TIMERx_IT_Disable
Function Prototype	Void TIMERx_IT_Disable(Typ_Timer_DITParameter DITValue)
Behaviour Description	Disables the interrupts. One or more input parameters can be passed by logically ORing them together.
Input Parameters	TIMER_OCMP_IT_DISABLE Disables the output compare interrupts TIMER_ICAP_IT_DISABLE ¹⁾ Disables the input capture interrupts TIMER_OVF_IT_DISABLE Disable the timer overflow interrupt
Output Parameters	None
Required Preconditions	Any Interrupts enabled.
Functions called	None
Postconditions	Interrupts are masked due to a particular flag.
See also	TIMERx_IT_Enable

1) Not available in ST72F65.

Note: Timer B available in ST72F521, ST72F264, ST72325 and ST7232A.

Table 79. TIMERx_OCMP_Mode

Function Name	TIMERx_OCMP_Mode
Function Prototype	Void TIMERx_OCMP_Mode(Timer_Compare CMP, unsigned int OCR_VALUE, Timer_Olevel OUTPUT_L)
Behaviour Description	Configures the timer in Output compare or Forced compare mode, depending upon the input parameter passed. This function should be called twice in order to get both the compare mode OCMP1 & OCMP2.
Input Parameter 1	<p>TIMER_OCMP_X X=1, output compare1 mode is selected. X=2, output compare2 mode is selected.</p> <p>TIMER_FORCDCMP_Y Y = 1, Forced compare 1 is selected. Y = 2, Forced compare 2 is selected.</p>
Input Parameter 2	<p>OCR_VALUE You can select this value from 0x0000 to 0xFFFF.</p>
Input Parameter 3	<p>TIMER_OUTPUT_F A low level is reflected at the output compare pin after successful comparison.</p> <p>TIMER_OUTPUT_R A high level is reflected at the output compare pin after successful comparison.</p>
Output Parameters	None
Required Preconditions	Timer correctly initialized.
Functions called	None
Postconditions	Timer starts functioning in either of the above selected mode and compare flag is set whenever the compare occurs.
See also	None

Note: If you select Forced compare mode, the input parameter 2 will not affect the output waveform and hence you can pass any value between 0x0000 to 0xFFFF.

Table 80. **TIMERx_ICAP_Mode**

Function Name	TIMERx_ICAP_Mode ¹⁾
Function Prototype	Void TIMERx_ICAP_Mode(Timer_Icap ICAP_I, Timer_Edge EDGE_SELECT_Y)
Behaviour Description	Configures the timer to Input capture mode. It determines the type of level transition on input capture pins. This function should be called twice in order to use both ICAP1 & ICAP2.
Input Parameter 1	TIMER_ICAP_I where I can be 1 or 2. I = 1, Input capture 1 is selected. I = 2, Input capture 2 is selected.
Input Parameter 2	TIMER_EDGE_Y where Y can be 0 or 1. Y= 0, Capture occurs at falling edge. Y= 1, Capture occurs at the rising edge.
Output Parameter	None
Required Preconditions	1. Input Capture pin used must be configured as floating input. 2. Only input capture 2 can be used if PWM or OPM is active.
Functions called	None
Postconditions	1. Timer configured for input capture mode. 2. To detect the occurrence of valid edge, you can poll the input capture flag using the function <code>TIMERx_Status_Flag</code> . This is in case you have not enabled the input capture interrupt.
See also	<code>TIMERx_Status_Flag</code> , <code>TIMERx_PWM_Mode</code> , <code>TIMERx_OPM_Mode</code> , <code>TIMERx_ICAP_Getvalue</code>

1) Function not available in ST72F65.

Table 81. TIMERx_PWM_Mode

Function Name	TIMERx_PWM_Mode ¹⁾
Function Prototype	Void TIMERx_PWM_Mode(Timer_Olevel OUTPUT1_L,Timer_Olevel OUTPUT2_L,unsigned int OCR1_VALUE,unsigned int OCR2_VALUE)
Behaviour Description	Configures the timer in Pulse width modulation mode. It enables the generation of a signal with frequency and duty cycle depending upon input parameters given by user. If both PWM and OPM modes are active then only PWM works. In PWM mode, ICAP1 pin cannot be used for input capture function, but ICAP2 can be used.
Input Parameter 1	TIMER_OUTPUT1_F Low level is reflected at the output compare1 pin after successful comparison of output compare1 register with free running counter. TIMER_OUTPUT1_R High level is reflected at the output compare1 pin after successful comparison of output compare1 register with free running counter.
Input Parameter 2	TIMER_OUTPUT2_F Low level is reflected at the output compare1 pin after successful comparison of output compare2 register with free running counter. TIMER_OUTPUT2_R High level is reflected at the output compare1 pin after successful comparison of output compare2 register with free running counter.
Input Parameter 3	OC1R_VALUE You can select this value from 0x0000 to 0xFFFF.
Input Parameter 4	OC2R_VALUE You can select this value from 0x0000 to 0xFFFF.
Output Parameters	None
Required Preconditions	1.Timer correctly configured. 2.Timer interrupt due to input capture 1 can be used by enabling the input capture interrupt.
Functions called	None
Postconditions	1.Timer is active in Pulse width modulation mode and waveform can be seen on OCMP1 pin. 2. Output compare interrupt is inhibited.
See also	TIMERx_Init,TIMERx_ICAP_Mode

1) Function not available in ST72F65.

Notes:

- Flags for compare1 & compare 2 can not be set by hardware in PWM mode, therefore the output compare interrupt is inhibited.

- The flag due to capture1 is set by hardware when counter reaches the output compare 2 register value and can produce the timer interrupt if the input capture interrupt is enabled and the instruction 'rim' is used to clear the '1' bit in CC register.
- By enabling the Forced compare mode or OPM mode while PWM mode is enabled, the polarity of the PWM Output waveform may change.

Table 82. TIMERx_OPM_Mode

Function Name	TIMERx_OPM_Mode ¹⁾
Function Prototype	Void TIMERx_OPM_Mode(Timer_Edge EDGE_SELECT_Y,Timer_Olevel OUTPUT1_L,Timer_Olevel OUTPUT2_L, unsigned int OCR_VALUE)
Behaviour Description	Configures the timer in One Pulse Mode. It enables the generation of a pulse when an external event occurs. If both PWM and OPM modes are active then OPM will not work. In OPM,OCMP1 cannot be used for output compare only OCMP2 is available for output compare.
Input Parameter 1	TIMER_EDGE_X X = 0, input capture1 occurs at falling edge. X = 1, input capture1 occurs at rising edge.
Input Parameter 2	TIMER_OUTPUT1_F Low level is reflected at the output compare1 pin after successful comparison of output compare1 register with free running counter. TIMER_OUTPUT1_R High level is reflected at the output compare1 pin after successful comparison of output compare1 register with free running counter.
Input Parameter 3	TIMER_OUTPUT2_F Low level is reflected at the output compare1 pin after successfully capturing edge at ICAP1 pin. TIMER_OUTPUT2_R High level is reflected at the output compare1 pin after successfully capturing edge at ICAP1 pin.
Input Parameter 4	OCR_VALUE You can select this value from 0x0000 to 0xFFFF.
Output Parameter	None
Required Preconditions	1. ICAP1 pin used must be configured as floating input. 2. To get OPM active, PWM must be disabled.
Functions called.	None
Postconditions	1. Input capture1 flag is set. 2.Timer is active in One pulse mode and waveform can be seen on OCMP1 pin. 3.Only Input capture 2 function can be used.
See also	TIMERx_PWM_Mode

1) Function not available in ST72F65.

Notes:

- The compare 1 flag can not be set by hardware but the compare interrupt can be generated when the compare 2 flag is set.

- To perform the input capture only the ICAP2 pin can be used, not the ICAP1 pin. Take care that the counter is reset each time a valid edge occurs on ICAP1 pin and that the capture 1 flag can also generate interrupts if the input capture interrupt is enabled and the 'rim' instruction has been used to clear the I-bit.
- When OPM is used, the input capture1 register is dedicated to this mode. Similarly output compare 2 cannot be used as level OLVL2 is dedicated to OPM.
- By enabling the Forced compare mode while OPM mode is enabled, the polarity of the OPM Output waveform may change.

Table 83. TIMERx_ICAP_Getvalue

Function Name	TIMERx_ICAP_Getvalue ¹⁾
Function Prototype	Unsigned int TIMERx_ICAP_Getvalue(Timer_Icap ICAP_I)
Behaviour Description	Returns the input capture1 or input capture 2 register value depending upon the input parameter passed. This function should be called twice in order to get both input capture1 and input capture2 register values.
Input Parameters	TIMER_ICAP_I where I can be 1 or 2. I = 1 Input capture 1 register value is returned I = 2 Input capture 2 register value is returned
Output Parameters	Input capture 1 or Input capture 2 register value. The returned value can be in the range 0x0000 to 0xFFFF.
Required Preconditions	ICF1 and/or ICF2 = 1 You have to call this function after the ICF1 and/or ICF2 flag is set, to get the capture value.
Functions called	None
Postconditions	Input capture 1 or Input capture 2 register value is returned.
See also	TIMERx_ICAP_Mode

1) Function not available in ST72F65.

Note: The input capture flag gets cleared if this function is called after the TIMERx_Status_Flag.

Table 84. TIMERx_Status_Flag

Function Name	TIMERx_Status_Flag
Function Prototype	Bool TIMERx_Status_Flag(Timer_Flag FLAG_F)
Behaviour Description	Checks the status of any one of the timer flags depending upon the input parameter. The function can be called more than once for checking more than one flag.
Input Parameters	<p>TIMER_FLAG_F where F can be OCF1, OCF2, ICF1, ICF2 or OVF. F = OCF1 checks for OCF1 flag F = OCF2 checks for OCF2 flag F = ICF1 checks for ICF1 flag ¹⁾ F = ICF2 checks for ICF2 flag ¹⁾ F = OVF check for OVF flag</p>
Output Parameters	<p>TRUE or FALSE If TRUE: flag is set. If FALSE: flag is not set.</p>
Required Preconditions	Timer must be configured in any one of the modes.
Functions called	None
Postconditions	<p>If TRUE, timer flag is set and can be cleared by calling TIMERx_Clear_Flag. If FALSE, timer flag is not set and this function can be looped till the flag is set.</p>
See also	TIMERx_Clear_Flag

1) Function not available in ST72F65.

Table 85. **TIMERx_Mode_Disable**

Function Name	TIMERx_Mode_Disable
Function Prototype	Void TIMERx_Mode_Disable(Timer_Mode MODE_M)
Behaviour Description	Disables the timer mode depending upon Input parameter passed. This function should be called more than once to disable more than one mode.
Input Parameter	TIMER_MODE_M where M can be 1, 2, 3, 4, 5, 6, 7, 8, 9. M=1, Output compare1 mode (OCMP1) M=2, Output compare 2 mode (OCMP2) M=3, Input capture 1 mode (ICAP1) ¹⁾ M=4, Input capture 2 mode (ICAP2) ¹⁾ M=5, Pulse width modulation mode (PWM) ¹⁾ M=6, One pulse modulation mode (OPM) ¹⁾ M=7, Forced compare1 mode (FORCDCMP1) M=8, Forced compare2 mode (FORCDCMP2) M=9, timer prescalar, counter and outputs disabled
Output Parameters	None
Required Preconditions	Timer active in any of the modes.
Functions called	None
Postconditions	Selected timer mode is disabled and the Corresponding status flag is cleared.
See also	None

1) Function not available in ST72F65.

Table 86. TIMERx_Clear_Flag

Function Name	TIMERx_Clear_Flag.
Function Prototype	Void TIMERx_Clear_Flag(Timer_Flag FLAG_F)
Behaviour Description	Clears the status flag depending upon the input parameter passed. This function can be called more than once to clear more than one flag.
Input Parameters	<p>TIMER_FLAG_F where F can be ICF1,ICF2,OCF1,OCF2 or OVF F = ICF1 ¹⁾ Clears the Input Capture1 Flag. F = ICF2 ¹⁾ Clears the Input Capture2 Flag. F = OCF1 Clears the output compare1 Flag. F = OCF2 Clears the output compare2 Flag. F = OVF Clears the timer overflow Flag.</p>
Output Parameters	None
Required Preconditions	ICF1=1 or ICF2=1 or OVF=1 or OCF1=1 or OCF2=1
Functions called	None
Postconditions	Selected status flag is cleared.
See also	TIMERx_IT_Routine,TIMERx_Status_Flag

1) Function not available in ST72F65.

EXAMPLE:

The following C program shows the use of the TIMERx functions. Here, x=A as TIMERA is used. You must define TIMERA in ST7lib_config.h.

Program description:

It compares the output compare2 register value with the free running counter, checks the occurrence of (event) leading edge at ICAP2 pin. It generates PWM signal with a frequency of 10KHz and a Duty cycle of 33% on the OCMP1 pin, if **_Enable_PWM_** is defined in ST7lib_conf1.h or it generates a 5ms pulse at OCMP1 pin, if **_Enable_OPM_** is defined in ST7lib_config.h (Fcpu = 8 MHz).

```

/* Program start */
#include "st7lib_config.h"

//prototype declaration
void main(void);
void TIMERA_IT_Routine(void);

void main(void)
{
    unsigned int OCR_VALUE = 0x2050;
    IO_Input (IO_FLOATING, IO_PORT_F, ((unsigned char) IO_PIN_5 | (unsigned char)
                                         IO_PIN_6));
                                         /* ICAP1, ICAP2 pins as floating input */
    TIMERA_Init (TIMER_FCPU_8);           /* Timer Clock to Fcpu/8 and reset counter */
    EnableInterrupts                       /* Clear I bit in CC reg */
    /* Timer compares 0x2050 with free running counter */
    TIMERA_OCMP_Mode (TIMER_OCMP_2, OCR_VALUE, TIMER_OUTPUT_R);
    while (!(TIMERA_Status_Flag (TIMER_FLAG_OCF2) == TRUE));
    TIMERA_Clear_Flag (TIMER_FLAG_OCF2);   /* Clear output compare2 flag */
    TIMERA_IT_Enable (TIMER_ICAP_IT_ENABLE); /* Enable capture interrupt */
    TIMERA_ICAP_Mode (TIMER_ICAP_2, TIMER_EDGE_1); /* Detect rising edge at ICAP2 pin */

    /* Run TIMERA in PWM mode if _Enable_PWM_ is defined */
    #ifdef _Enable_PWM_
        /* Generate PWM */
        TIMERA_PWM_Mode (TIMER_OUTPUT1_F, TIMER_OUTPUT2_R, (unsigned int) 0x001C,
                        (unsigned int) 0x005F);
    #endif

    /* Run TIMERA in OPM mode if _Enable_OPM_ is defined */
    #ifdef _Enable_OPM_
        TIMERA_Clear_Flag (TIMER_FLAG_ICF1); /* Clear Input capture1 Flag */
        TIMERA_Mode_Disable (TIMER_MODE_5); /* Disable PWM */
        TIMERA_OPM_Mode (TIMER_EDGE_1, TIMER_OUTPUT1_F, TIMER_OUTPUT2_R,
                        (unsigned int) 0x1383);
    #endif
    while(1); /* 5ms pulse */
    /* For testing only */
}
/* Program end */

/* -----
ROUTINE NAME : TIMERA_IT_Routine
INPUT      : None
OUTPUT     : None

```

Function Descriptions

DESCRIPTION : Interrupt service routine

COMMENTS : This gets automatically executed when any of the timer interrupt is enabled. If the same functions are called in the main Tree and the interrupt Tree, the function Re-entrant error occurs in case COSMIC compiler is used with models other than stack models.
The timer_hr.h is included as the actual hardware register are read to clear the flags. For configuring the port pins, I/O library is used.

```
-----*/
#ifdef USE_TIMER_A
#ifdef _HIWARE_ /* Test for HIWARE Compiler */
#pragma TRAP_PROC SAVE_REGS /* Additional registers will be saved */
#else
#ifdef _COSMIC_ /* Test for Cosmic Compiler */
@interrupt
#else
#error "Unsupported Compiler!" /* Compiler Defines not found! */
#endif
#endif
void TIMERA_IT_Routine(void)
{
    unsigned int CAP2_Value; /* Define local variables */
    unsigned char i,Temp;
    if(TACSR & 0x10)
        /* if(TIMERA_Status_Flag(TIMER_FLAG_ICF1)==TRUE) Call to Check ICF2 */
    {
        Temp = TACSR; /* Clear ICF2 */
        Temp = TAIC2LR;
        /* TIMERA_Clear_Flag(TIMER_FLAG_ICF2); Call to clear ICF2 */
        /* call to get capture value and also clear ICF2 */
        CAP2_Value = TIMERA_ICAP_Getvalue(TIMER_ICAP_2);
        /* Port PB0 pushpull output */
        IO_Output (IO_PUSH_PULL, IO_PORT_B, IO_PIN_0);
        IO_Write (IO_PORT_B, IO_PIN_0, IO_DATA_HIGH); /* Turn ON LED at PB0 */
        //turn on LED when input capture occurs
        for(i=0;i<=250;i++) /* Delay */
        {
            Nop
        }
        IO_Write (IO_PORT_B, IO_PIN_0, IO_DATA_LOW); /* Turn ON LED at PC0 */
    }
}
#endif
```

9.1.7 8-bit TIMER (TIMER8)

The software library for the 8-bit Timer supports the following function.

Note: Currently Timer8 is only available for ST72F561.

Function Name	TIMER8_Init
Function Prototype	Void TIMER8_Init(Typ_Timer8_InitParameter InitValue)
Behaviour Description	Initializes the timer8 control registers and status register to their default values. Timer8 clock can be selected as Fcpu/2, Fcpu/8 and Fcpu/8000. Default value of clock is Fcpu/4.
Input Parameters	TIMER8_FCPU_2 Timer clock is set to Fcpu/2 TIMER8_FCPU_4 Timer clock is set to Fcpu/4 TIMER8_FCPU_8 Timer clock is set to Fcpu/8 TIMER8_FCPU_8000 Timer clock is set to Fcpu/8000 TIMER8_DEFAULT Reset value (Default value)
Output Parameters	None
Required Preconditions	None
Functions called	None
Postconditions	Timer8 clock is configured correctly.
See also	None

Table 87. TIMER8_IT_Enable

Function Name	TIMER8_IT_Enable
Function Prototype	Void TIMER8_IT_Enable(Typ_Timer8_EITParameter EITValue)
Behaviour Description	Enables the timer8 interrupts. One or more input parameters can be passed by logically ORing them together.
Input Parameters	TIMER8_OCMP_IT_ENABLE Enables the output compare interrupts TIMER8_ICAP_IT_ENABLE Enables the input capture interrupts TIMER8_OVF_IT_ENABLE Enables the timer overflow interrupt
Output Parameters	None
Required Preconditions	None
Functions called	None
Postconditions	Interrupt is enabled for a particular flag. You also have to enable the interrupt with instruction 'rim'.
See also	TIMER8_IT_Disable

Table 88. TIMER8_IT_Disable

Function Name	TIMER8_IT_Disable
Function Prototype	Void TIMER8_IT_Disable(Typ_Timer8_DITParameter DITValue)
Behaviour Description	Disables the interrupts. One or more input parameters can be passed by logically ORing them together.
Input Parameters	TIMER8_OCMP_IT_DISABLE Disables the output compare interrupts TIMER8_ICAP_IT_DISABLE Disables the input capture interrupts TIMER8_OVF_IT_DISABLE Disable the timer overflow interrupt
Output Parameters	None
Required Preconditions	Any Interrupts enabled.
Functions called	None
Postconditions	Interrupt is masked due to a particular flag.
See also	TIMER8_IT_Enable

Table 89. TIMER8_OCMP_Mode

Function Name	TIMER8_OCMP_Mode
Function Prototype	Void TIMER8_OCMP_Mode(Timer8_Compare CMP, unsigned char OCR_VALUE, Timer8_Olevel OUTPUT_L)
Behaviour Description	Configures the timer8 in Output compare or Forced compare mode, depending upon the input parameter passed. This function should be called twice in order to get both the compare mode OCMP1 & OCMP2.
Input Parameter 1	TIMER8_OCMP_X X=1, output compare1 mode is selected. X=2, output compare2 mode is selected. TIMER8_FORCDCMP_Y Y = 1, Forced compare1 is selected. Y = 2, Forced compare2 is selected.
Input Parameter 2	OCR_VALUE You can select this value from 0x00 to 0xFC.
Input Parameter 3	TIMER8_OUTPUT_F A low level is reflected at the output compare pin after successful comparison. TIMER8_OUTPUT_R A high level is reflected at the output compare pin after successful comparison.
Output Parameters	None
Required Preconditions	Timer correctly initialized.
Functions called	None
Postconditions	Timer8 starts functioning in either of the above selected modes, and the compare flag is set whenever the compare occurs.
See also	None

Note: When the Forced compare mode is selected, the input parameter 2 will not affect the output waveform and hence you can pass any value between 0x00 to 0xFC.

Table 90. TIMER8_ICAP_Mode

Function Name	TIMER8_ICAP_Mode
Function Prototype	Void TIMER8_ICAP_Mode(Timer8_Icap ICAP_I, Timer8_Edge EDGE_SELECT_Y)
Behaviour Description	Configures the timer8 to Input capture mode. It determines the type of level transition occurred on input capture pins. This function should be called twice in order to use both ICAP1 & ICAP2.
Input Parameter 1	TIMER8_ICAP_I where I can be 1 or 2. I = 1, Input capture 1 is selected. I = 2, Input capture 2 is selected.
Input Parameter 2	TIMER8_EDGE_Y where Y can be 0 or 1. Y= 0, Capture occurs at falling edge. Y= 1, Capture occurs at the rising edge.
Output Parameter	None
Required Preconditions	1. Input Capture pin used must be configured as floating input or pull up without interrupt. 2. Only input capture2 can be used if PWM or OPM is active.
Functions called	None
Postconditions	1. Timer8 configured for input capture mode. 2. To detect the occurrence of valid edge, you can poll the input capture flag using the function TIMER8_Status_Flag. This is in case you have not enabled the input capture interrupt.
See also	TIMER8_Status_Flag, TIMER8_PWM_Mode, TIMER8_OPM_Mode, TIMER8_ICAP_Getvalue

Table 91. TIMER8_PWM_Mode

Function Name	TIMER8_PWM_Mode
Function Prototype	Void TIMER8_PWM_Mode(Timer8_Olevel OUTPUT1_L,Timer8_Olevel OUTPUT2_L,unsigned char OCR1_VALUE,unsigned char OCR2_VALUE)
Behaviour Description	Configures the timer8 in Pulse width modulation mode. It enables the generation of a signal with frequency and duty cycle depending upon the input parameters you have given. If PWM and OPM modes are both active then only PWM works. In PWM mode, the ICAP1 pin cannot be used for input capture function, but ICAP2 can be used.
Input Parameter 1	TIMER8_OUTPUT1_F Low level is reflected at the output compare1 pin after successful comparison of output compare1 register with free running counter. TIMER8_OUTPUT1_R High level is reflected at the output compare1 pin after successful comparison of output compare1 register with free running counter.
Input Parameter 2	TIMER8_OUTPUT2_F Low level is reflected at the output compare1 pin after successful comparison of output compare2 register with free running counter. TIMER8_OUTPUT2_R High level is reflected at the output compare1 pin after successful comparison of output compare2 register with free running counter.
Input Parameter 3	OC1R_VALUE You can select this value from 0x00 to 0xFC.
Input Parameter 4	OC2R_VALUE You can select this value from 0x00 to 0xFC.
Output Parameters	None
Required Preconditions	1.Timer8 correctly configured. 2.Timer8 interrupt due to input capture1 can be used by enabling the input capture interrupt.
Functions called	None
Postconditions	1.Timer8 is active in Pulse width modulation mode and waveform can be seen on OCMP1 pin. 2. Output compare interrupt is inhibited.
See also	TIMER8_Init,TIMER8_ICAP_Mode

Notes:

- Flags for compare1 & compare2 can not be set by hardware in PWM mode, therefore the output compare interrupt is inhibited.

Function Descriptions

- The flag due to capture1 is set by hardware when the counter reaches the output compare2 register value and can produce the timer interrupt if the interrupt for input capture is enabled and the instruction 'rim' is used to clear the 'I' bit in CC register.
- By enabling the Forced compare mode or OPM mode while PWM mode is enabled, the polarity of the PWM Output waveform may change.

Table 92. TIMER8_OPM_Mode

Function Name	TIMER8_OPM_Mode ¹⁾
Function Prototype	Void TIMER8_OPM_Mode(Timer8_Edge EDGE_SELECT_Y,Timer8_Olevel OUTPUT1_L,Timer8_Olevel OUTPUT2_L, unsigned char OCR_VALUE)
Behaviour Description	Configures the timer8 in One Pulse Mode. It enables the generation of pulse when an external event occurs. If PWM and OPM modes are both active then OPM will not work. In OPM mode, OCMP1 cannot be used for output compare, only OCMP2 is available for output compare.
Input Parameter 1	TIMER8_EDGE_X X = 0, input capture1 occurs at falling edge. X = 1, input capture1 occurs at rising edge.
Input Parameter 2	TIMER8_OUTPUT1_F Low level is reflected at the output compare1 pin after successful comparison of output compare1 register with free running counter. TIMER8_OUTPUT1_R High level is reflected at the output compare1 pin after successful comparison of output compare1 register with free running counter.
Input Parameter 3	TIMER8_OUTPUT2_F Low level is reflected at the output compare1 pin after successfully capturing edge at ICAP1 pin. TIMER8_OUTPUT2_R High level is reflected at the output compare1 pin after successfully capturing edge at ICAP1 pin.
Input Parameter 4	OCR_VALUE You can select this value from 0x00 to 0xFC.
Output Parameter	None
Required Preconditions	1.ICAP1 pin used must be configured as floating input. 2.To get OPM active, PWM must be disabled.
Functions called.	None
Postconditions	1. Input capture1 flag is set. 2.Timer is active in One pulse mode and waveform can be seen on OCMP1 pin. 3.Only Input capture2 function can be used.
See also	TIMER8_PWM_Mode

1) Function not available in ST72F65.

Notes:

- Flag due to compare1 cannot be set by hardware but the compare interrupt can be generated due to the setting of compare2 flag.

- Only the ICAP2 pin can be used to perform input capture, not the ICAP1 pin. Take care that the counter is reset each time a valid edge occurs on the ICAP1 pin and capture 1 flag can also generate an interrupt if input capture interrupt is enabled and the instruction 'rim' is used to clear the I bit.
- When OPM is used, input capture1 register is dedicated to this mode. Similarly output compare2 cannot be used as level OLVL2 is dedicated to OPM.
- By enabling the Forced compare mode while OPM mode is enabled, the polarity of the OPM Output waveform may change.

Table 93. TIMER8_ICAP_Getvalue

Function Name	TIMER8_ICAP_Getvalue
Function Prototype	Unsigned char TIMER8_ICAP_Getvalue(Timer8_Icap ICAP_I)
Behaviour Description	Returns the input capture1 or input capture2 register value depending upon the input parameter passed. This function should be called twice in order to get both input capture1 and input capture2 register values.
Input Parameters	TIMER8_ICAP_I where I can be 1 or 2. I = 1 Input capture1 register value is returned I = 2 Input capture2 register value is returned
Output Parameters	Input capture1 or Input capture2 register value. The returned value can be in the range 0x00 to 0xFC.
Required Preconditions	ICF1 and/or ICF2 = 1 You have to call this function after the ICF1 and/or ICF2 flag is set, to get the capture value.
Functions called	None
Postconditions	Input capture1 or Input capture2 register value is returned.
See also	TIMER8_ICAP_Mode

Note: The input capture flag gets cleared if this function is called after the TIMER8_Status_Flag.

Table 94. **TIMER8_Status_Flag**

Function Name	TIMER8_Status_Flag
Function Prototype	Bool TIMER8_Status_Flag(Timer8_Flag FLAG_F)
Behaviour Description	Checks the status of any one of the timer flags depending upon the input parameter. The function can be called more than once for checking more than one flag.
Input Parameters	<p>TIMER8_FLAG_F where F can be OCF1, OCF2, ICF1, ICF2 or OVF. F = OCF1 checks for OCF1 flag F = OCF2 checks for OCF2 flag F = ICF1 checks for ICF1 flag F = ICF2 checks for ICF2 flag F = OVF check for OVF flag</p>
Output Parameters	<p>TRUE or FALSE If TRUE: flag is set. If FALSE: flag is not set.</p>
Required Preconditions	Timer8 must be configured in any one of the modes.
Functions called	None
Postconditions	<p>If TRUE, timer8 flag is set and can be cleared by calling TIMER8_Clear_Flag. If FALSE, timer8 flag is not set and this function can be looped till the flag is set.</p>
See also	TIMER8_Clear_Flag

Table 95. TIMER8_Mode_Disable

Function Name	TIMER8_Mode_Disable
Function Prototype	Void TIMER8_Mode_Disable(Timer8_Mode MODE_M)
Behaviour Description	Disables the timer8 mode depending upon the Input parameter passed. This function should be called more than once in order to disable more than one mode.
Input Parameter	<p>TIMER8_MODE_M</p> <p>where M can be 1, 2, 3, 4, 5, 6, 7, 8, 9.</p> <p>M=1, Output compare1 mode (OCMP1)</p> <p>M=2, Output compare2 mode (OCMP2)</p> <p>M=3, Input capture1 mode (ICAP1)</p> <p>M=4, Input capture2 mode (ICAP2)</p> <p>M=5, Pulse width modulation mode (PWM).</p> <p>M=6, One pulse modulation mode (OPM)</p> <p>M=7, Forced compare1 mode (FORCDCMP1)</p> <p>M=8, Forced compare2 mode (FORCDCMP2)</p> <p>M=9, Timer prescaler, counter and outputs disabled</p>
Output Parameters	None
Required Preconditions	Timer8 active in any of the modes.
Functions called	None
Postconditions	Selected timer8 mode is disabled and the Corresponding status flag is cleared.
See also	None

Table 96. TIMER8_Clear_Flag

Function Name	TIMER8_Clear_Flag.
Function Prototype	Void TIMER8_Clear_Flag(Timer8_Flag FLAG_F)
Behaviour Description	Clears the status flag depending upon the input parameter passed. This function can be called more than once to clear more than one flag.
Input Parameters	<p>TIMER8_FLAG_F where F can be ICF1,ICF2,OCF1,OCF2 or OVF</p> <p>F = ICF1 Clears the Input Capture1 Flag.</p> <p>F = ICF2 Clears the Input Capture2 Flag.</p> <p>F = OCF1 Clears the output compare1 Flag.</p> <p>F = OCF2 Clears the output compare2 Flag.</p> <p>F = OVF Clears the timer overflow Flag.</p>
Output Parameters	None
Required Preconditions	ICF1=1 or ICF2=1 or OVF=1 or OCF1=1 or OCF2=1
Functions called	None
Postconditions	Selected status flag is cleared.
See also	TIMER8_IT_Routine,TIMER8_Status_Flag

EXAMPLE:

The following C program shows the use of the TIMER8 functions.

Program description:

It compares the output compare2 register value with the free running counter, checks the occurrence of (event) leading edge at ICAP2 pin. It generates PWM signal with 10KHz frequency and with 33% Duty cycle at the OCMP1 pin if **_Enable_PWM_** is defined in main.c or it generates the 0.1ms pulse at OCMP1 pin, if **_Enable_OPM_** is defined in main.c (Fcpu = 8 MHz).

```
/* Program start */

#include "st7lib_config.h" /* File for user to select the required device */

//prototype declaration
void main(void);
void TIMER8_IT_Routine(void);

void main(void)
{
    unsigned char TIMER8_OCR_VALUE = 0x50;
    /* Configuring the Port B pin 0 & 2 as floating for ICAP1 and ICAP2 */
    IO_Input(IO_FLOATING, IO_PORT_B, ((unsigned char) IO_PIN_0 | (unsigned char)
                                     IO_PIN_2));
    TIMER8_Init (TIMER8_FCPU_8); /* Timer8 Clock to Fcpu/8 and reset counter */
    EnableInterrupts /* Clear I bit in CC reg */
    /* Timer8 compares 0x50 with free running counter */
    TIMER8_OCMP_Mode(TIMER8_OCMP_2, TIMER8_OCR_VALUE, TIMER8_OUTPUT_R);
    while (!(TIMER8_Status_Flag(TIMER8_FLAG_OCF2) == TRUE));
    TIMER8_Clear_Flag(TIMER8_FLAG_OCF2); /* Clear output compare2 flag */
    TIMER8_IT_Enable(TIMER8_ICAP_IT_ENABLE); /* Enable capture interrupt */
    /* Detect rising edge at ICAP2 pin */
    TIMER8_ICAP_Mode(TIMER8_ICAP_2, TIMER8_EDGE_1);

    /* Run TIMER8 in PWM mode if _Enable_PWM_ is defined */
    #ifdef _Enable_PWM_ /* Generate PWM of frequency of 10 KHz */
        TIMER8_PWM_Mode(TIMER8_OUTPUT1_F, TIMER8_OUTPUT2_R, 0x1C, 0x5F);
    #endif

    /* Run TIMER8 in OPM mode if _Enable_OPM_ is defined */
    #ifdef _Enable_OPM_
        TIMER8_Clear_Flag(TIMER8_FLAG_ICF1); /* Clear Input capture1 Flag */
        TIMER8_Mode_Disable(TIMER8_MODE_5); /* Disable PWM */
        /* 0.1ms pulse */
        TIMER8_OPM_Mode(TIMER8_EDGE_1, TIMER8_OUTPUT1_F, TIMER8_OUTPUT2_R, 0x5F);
    #endif
    while(1); /* For testing only */
}
/* Program end */
```

```

/* -----
ROUTINE NAME : TIMER8_IT_Routine
INPUT      : None
OUTPUT     : None
DESCRIPTION : Interrupt service routine
COMMENTS   : This gets automatically executed when any of the timer8
              interrupt is enabled. If the same functions are called in the
              main Tree and the interrupt Tree, the function Re-entrant error
              occurs in case COSMIC compiler is used with models other than
              stack models. For configuring the port pins, I/O library is used.
-----*/
#ifdef _HIWARE_                                     /* Test for HIWARE Compiler */
#pragma TRAP_PROC SAVE_REGS                         /* Additional registers will be saved */
#else
#ifdef _COSMIC_                                     /* Test for Cosmic Compiler */
@interrupt
#else
#error "Unsupported Compiler!"                     /* Compiler Defines not found! */
#endif
#endif
void TIMER8_IT_Routine(void)
{
    unsigned int CAP2_Value;                         /* Define local variables */
    unsigned char i,Temp;

    if(T8CSR & 0x10)
    /* if(TIMER8_Status_Flag(TIMER8_FLAG_ICF2)==TRUE) Call to Check ICF2 */
    {
        Temp = T8CSR;                               /* Clear ICF2 */
        Temp = T8IC2R;
        /* TIMER8_Clear_Flag(TIMER8_FLAG_ICF2);      Call to clear ICF2 */
        /* call to get capture value and also clear ICF2 */
        CAP2_Value = TIMER8_ICAP_Getvalue(TIMER8_ICAP_2);
        /* Port PA0 pushpull output */
        IO_Output(IO_PUSH_PULL, IO_PORT_A, IO_PIN_0);

        IO_Write(IO_PORT_A, IO_PIN_0, IO_DATA_HIGH); /* Port PA0 made high */
        for(i=0;i<=250;i++)                          /* Delay */
        {
            Nop
        }
        IO_Write(IO_PORT_A, IO_PIN_0, IO_DATA_LOW); /* Port A0 made low */
    }
}

```

9.1.8 LITE TIMER (LT)

This software library consists of the following functions for LT.

Function Name	LT_Init
Function Prototype	Void LT_Init(Lt_InitParameter InitValue)
Behaviour Description	Initialization of the LT, by default sets Timebase as 1ms, watchdog and interrupts disabled. It initializes the input capture flag. To change this default configuration, you can pass one or more input parameters by logically ORing them together.
Input Parameter	LT_ICAP_IT_ENABLE enables input capture interrupt LT_TB_IT_ENABLE ¹⁾ enables Timebase interrupt LT_TB1_IT_ENABLE ²⁾ enables Timebase1 interrupt LT_TB2_IT_ENABLE ²⁾ enables Timebase2 interrupt LT_DEFAULT sets default configuration
Output Parameters	None
Required Preconditions	None
Functions called	None
Postconditions	LT is configured as desired
See also	LT_TB

1) Present in ST7FLITE0 and ST7SUPERLITE.

2) Present in ST7FLITE1/2/3 and ST7FDALI.

Note: By default this function also sets the timebase to 1ms. To change the timebase to 2ms, you can use the LT_TB function.

Table 97. LT_WDG_Enable

Function Name	LT_WDG_Enable
Function Prototype	Void LT_WDG_Enable(void)
Behaviour Description	Enables the watchdog.
Input Parameter	None
Output Parameters	None
Required Preconditions	None
Functions called	None
Postconditions	Watchdog is enabled. You can call LT_WDG_Reset to delay or force the watchdog reset.
See also	LT_WDG_Reset

Note: This function works only for ST7FLITE0 and ST7SUPERLITE.

Table 98. LT_TB

Function Name	LT_TB
Function Prototype	Void LT_TB(Lt_TB_Param TBValue)
Behaviour Description	Sets Timebase to 1ms or 2ms depending upon the input parameter passed.
Input Parameter 1	LT_SET_TB_1 sets Timebase =1ms LT_SET_TB_2 sets Timebase = 2ms
Output Parameters	None
Required Preconditions	None
Functions called	None
Postconditions	Timebase selected is 1ms or 2ms depending upon the input parameter passed.
See also	LT_Init

Table 99. LT_ARR_WriteValue

Function Name	LT_ARR_WriteValue ¹⁾
Function Prototype	Void LT_ARR_WriteValue(unsigned char)
Behaviour Description	Loads the specified value in the AutoReload Register
Input Parameter	Unsigned char value from 0x00 to 0xFF.
Output Parameters	None
Required Preconditions	None
Functions called	None
Postconditions	None
See also	LT_ARR_ReadValue

1) This function is present only in ST7FLite 1/2/3 and ST7FDALI.

Table 100. LT_ARR_ReadValue

Function Name	LT_ARR_ReadValue ¹⁾
Function Prototype	Unsigned char LT_ARR_ReadValue(void)
Behaviour Description	Reads the value from the AutoReload Register
Input Parameter	None
Output Parameters	Unsigned char
Required Preconditions	None
Functions called	None
Postconditions	Reads from the AutoReload Register with the specified value which is automatically loaded from the Counter Register when overflow occurs.
See also	LT_ARR_WriteValue

1) This function is present only in ST7FLite 1/2/3 and ST7FDALI.

Table 101. LT_CNTR_ReadValue

Function Name	LT_CNTR_ReadValue ¹⁾
Function Prototype	Unsigned char LT_CNTR_ReadValue (void)
Behaviour Description	Reads the value from the Counter Register
Input Parameter	None
Output Parameters	Unsigned char
Required Preconditions	None
Functions called	None
Postconditions	None
See also	LT_ARR_ReadValue

1) This function is present only in ST7FLite 1/2/3 and ST7FDALI.

Table 102. LT_Disable

Function Name	LT_Disable
Function Prototype	Void LT_Disable(Lt_Disable_Param DValue)
Behaviour Description	Disables input capture interrupt or Timebase interrupt or watchdog or all of these depending upon the input parameter passed. More than one parameter can be passed by logically ORing them together.
Input Parameter	LT_ICAP_IT_DISABLE disables input capture interrupt LT_TB_IT_DISABLE ¹⁾ disables Timebase interrupt LT_TB1_IT_DISABLE ²⁾ disables Timebase1 interrupt LT_TB2_IT_DISABLE ²⁾ disables Timebase2 interrupt LT_WDG_DISABLE ¹⁾ disables watchdog
Output Parameters	None
Required Preconditions	Interrupts or watchdog enabled
Functions called	None
Postconditions	Input capture interrupt or Timebase interrupt or watchdog disabled depending upon the input parameter passed.
See also	LT_Init

1) Present in ST7FLITE0 and ST7SUPERLITE.

2) Present in ST7FLITE1/2/3 and ST7FDALI.

Table 103. LT_WDG_Reset

Function Name	LT_WDG_Reset
Function Prototype	Void LT_WDG_Reset(Lt_Reset_Param WDGValue)
Behaviour Description	Delays or forces watchdog reset depending upon the input parameter passed.
Input Parameter	LT_DELAY_WDG_RESET watchdog reset delay by t_{WDG} ¹⁾ LT_FORCD_WDG_RESET force a watchdog reset
Output Parameters	None
Required Preconditions	Watchdog enabled
Functions called	None
Postconditions	Watchdog reset occurred or delayed depending upon the input parameter passed.
See also	LT_Init

1. $t_{WDG} = 2ms @ 8 MHz fosc$, therefore You have to use this option at regular intervals to prevent a watchdog reset occurring.

Note: The function can be used for ST7FLite0, ST7SUPERLITE and ST7FDALI.

Table 104. LT_ICAP_Getvalue

Function Name	LT_ICAP_Getvalue
Function Prototype	Unsigned char LT_ICAP_Getvalue(void)
Behaviour Description	Returns the input capture register value.
Input Parameters	None
Output Parameters	Input capture register value as unsigned character. The returned value can be in the range of 0x00 to 0xF9.
Required Preconditions	ICF =1 You have to call this function after the ICF flag is set, to get the capture value.
Functions called	None
Postconditions	1.Input capture register value is returned. 2.Input capture flag is cleared.
See also	None

Table 105. LT_Status_Flag

Function Name	LT_Status_Flag
Function Prototype	BOOL LT_Status_Flag(Lt_Flag FLAG_F)
Behaviour Description	Checks the status of any one of the LT flags depending upon the input parameter passed. The function can be called more than once for checking more than one flag.
Input Parameters	LT_FLAG_TBF ¹⁾ checks for Timebase interrupt flag LT_FLAG_TB1F ²⁾ checks for Timebase1 interrupt flag LT_FLAG_TB2F ²⁾ checks for Timebase2 interrupt flag LT_FLAG_ICF checks for input capture flag LT_FLAG_WDGRF ¹⁾ checks for watchdog reset status flag
Output Parameters	TRUE or FALSE If TRUE: flag is set If FALSE: flag is not set.
Required Preconditions	LT configured in any one of the modes.
Functions called	None
Postconditions	If the output parameter is TRUE, flag is set. If the output parameter is FALSE, the flag is not set and this function can be looped till the flag is set.
See also	None

1) Defined for ST7FLITE0 and ST7SUPERLITE.

2) Defined for ST7FLITE1/2/3 and ST7FDALI.

Note: After calling this function for a particular flag, the corresponding flag is cleared when the TRUE is returned

Table 106. LT_Clear_Flag

Function Name	LT_Clear_Flag
Function Prototype	Void LT_Clear_Flag(Lt_Flag FLAG_F)
Behaviour Description	Clears the status flag depending upon the input parameter passed. This function can be called more than once to clear more than one flag.
Input Parameters	LT_FLAG_TBF ¹⁾ clears the Timebase interrupt flag LT_FLAG_TB1F ²⁾ clears the Timebase1 interrupt flag LT_FLAG_TB2F ²⁾ clears the Timebase2 interrupt flag LT_FLAG_ICF ³⁾ clears the input capture flag LT_FLAG_WDGRF ⁴⁾ clears the watchdog reset status flag
Output Parameters	None
Required Preconditions	TBF=1 or TB1F=1 or TB2F=1 or ICF=1 or WDGRF=1
Functions called	None
Postconditions	Selected status flag is cleared.
See also	LT_Status_Flag

1) Defined for ST7FLITE0 and ST7SUPERLITE.

2) Defined for ST7FLITE1/2/3 and ST7FDALI.

3) Defined for ST7FLITE0 and ST7SUPERLITE.

Note: After reset, calling this function with the input parameter FLAG_ICF also initializes the input capture. The input capture is inhibited if the ICF flag is set.

EXAMPLE:

The following C program example shows the use of the LT functions for the ST7FLite0 device.

Program description:

This program detects an event (rising edge & trailing edge) at the LTIC pin and toggles a LED every 5 seconds.

```

/* Program start */

#include "ST7lib_config.h"                                /* select ST7FLITE0 */
#define LT_WDG

//prototype declaration
void LT_ICAP_IT_Routine(void);
void LT_TB_IT_Routine(void);

```

```

void main(void);

volatile unsigned int count;
void main (void)
{
    /* PB3 and PB1 as pushpull output */
    IO_Output (IO_PUSH_PULL, IO_PORT_B, ((unsigned char) IO_PIN_3 |
                                         (unsigned char) IO_PIN_1 ));

    /*Set Time base to lms, Input capture and Timebase interrupts enabled */
    LT_Init(((unsigned char)LT_ICAP_IT_ENABLE| (unsigned char)LT_TB_IT_ENABLE));
    /* Clear I bit in CC register */
    EnableInterrupts                               /* Micro defined in the st7lib_config.h */
#ifdef LT_WDG                                     /* Use of force watchdog reset */
        LT_WDG_Enable();
        LT_WDG_Reset (LT_FORCD_WDG_RESET);
#endif /* LT_WDG_ */
    while(1);                                     /* For Testing only */
}

                                                /* Program end */

/*****
Use of Input capture Interrupt service routine
- User has to write this function and map the interrupt vector in .prm file in
  case of HIWARE or in vector_xxx.c in case of COSMIC.
- An example of LED toggles at port PB1 is given, which will be executed when
  capture occurs.
- This gets automatically executed if the ICAP interrupt of the LT is enabled.
  If the same functions are called in the main Tree and the interrupt Tree, the
  function Reentrant error occurs in case COSMIC compiler is used with models
  other than stack models.
Functions description
- The lt_hr.h is to be included when the actual hardware register are read to
  clear the flags.For configuring the port pins, I/O library is used.
*****/

#ifdef _HIWARE_                                     /* Test for HIWARE Compiler */
#pragma TRAP_PROC SAVE_REGS                         /* Additional registers will be saved */
#else
#ifdef _COSMIC_                                     /* Test for Cosmic Compiler */
@interrupt @nostack
#else
#error "Unsupported Compiler!"                     /* Compiler Defines not found! */
#endif
#endif
void LT_IC_IT_Routine(void)
{
    unsigned char ICAP_Value, i;
    /* i = LTICR; Clear ICF */
    LT_Clear_Flag(LT_FLAG_ICF);                    /* Call only to clear ICF */
    ICAP_Value = LT_ICAP_Getvalue();                /* Get capture value and also clear ICF */
    IO_Write (IO_PORT_B, IO_PIN_1, IO_DATA_HIGH); /* Turn ON LED at PB1 */
    for ( i=0; i<=100; i++)                          /* Delay */
    {
        Nop
    }
}

```

Function Descriptions

```
    }
    IO_Write (IO_PORT_B,IO_PIN_1,IO_DATA_LOW);          /* Turn OFF LED at PB1 */
}

/*****
Use of TimebaseInterrupt service routine
- User has to write this function and map the interrupt vector in .prm file in
  case of HIWARE or in vector_xxx.c in case of COSMIC.
- An example of LED toggles after every 5 seconds is given.This routine is
  executed when overflow occurs (TBF=1) .
- This gets automatically executed when TBF interrupt of the LT is enabled. If
  the same functions are called in the main Tree and the interrupt Tree, the
  function Reentrant error occurs in case COSMIC compiler is used with models
  other than stack models.
Functions description
- The lt_hr.h is to be included when the actual hardware register are read to
  clear the flags.For configuring the port pins, I/O library is used.
*****/
#ifdef _HIWARE_                                     /* Test for HIWARE Compiler */
#pragma TRAP_PROC SAVE_REGS                        /* Additional registers will be saved */
#else
#ifdef _COSMIC_                                     /* Test for Cosmic Compiler */
@interrupt @nostack
#else
#error "Unsupported Compiler!"                    /* Compiler Defines not found! */
#endif
#endif
void LT_TB_IT_Routine(void)
{
    unsigned char Temp;
    /* i = LTCSR; Clear ICF */
    LT_Clear_Flag(LT_FLAG_TBF);                    /* Call only to clear TBF */
    /* Routine up to the user */
    count++;
    if(count == 5000)
    {
        Temp = IO_Read (IO_PORT_B );              /* TO Toggle PB3 */
        if (Temp & 0x08)
        {
            IO_Write (IO_PORT_B,IO_PIN_3,IO_DATA_LOW); /* Turn OFF LED at PB3 */
        }
        else
        {
            IO_Write (IO_PORT_B,IO_PIN_3,IO_DATA_HIGH); /* Turn ON LED at PB3 */
        }
        count = 0;
    }
}
}
```

9.1.9 PWMART

This software library for PWMART consists of the following functions:

Function Name	PWMART_Init
Function Prototype	Void PWMART_Init(Typ_Pwmart_InitParameter InitValue)
Behaviour Description	Initialization of the PWMART, by default sets counter clock as Fcpu, counter stopped and interrupt disabled. You can select external clock. One or more input parameters can be passed by logically ORing them together.
Input Parameter	PWMART_DEFAULT Reset value (00h) PWMART_EXCLK Enable the external clock source PWMART_OVF_IT_ENABLE Enable counter overflow interrupt
Output Parameters	None
Required Preconditions	None
Functions called	None
Postconditions	PWMART is configured as desired
See also	PWMART_Counter_Enable

Table 107. PWMART_Counter_Enable

Function Name	PWMART_Counter_Enable
Function Prototype	Void PWMART_Counter_Enable(Pwmart_Counter_SELECT_REG,unsigned char Counter_Data, Pwmart_Clock_SELECT_CLK)
Behaviour Description	Initializes the PWM counter. You can select counter frequency.
Input Parameter 1	PWMART_REG_C where C can be CAR or ARR If C = ARR; Counter is forced to be loaded with ARR register at each overflow, automatically and clears prescaler register. If C = CAR; Counter is loaded with CAR register on the fly and clears prescaler register.
Input Parameter 2	Counter_Data Data to be loaded in ARR register or CAR register. Data can be selected from 0x00 to 0xFF.
Input Parameter 3	PWMART_CLK_PR where PR can be 1,2,4,8,16,32,64 or 128 PR = 1, $f_{\text{COUNTER}} = f_{\text{INPUT}}$ PR = 2, $f_{\text{COUNTER}} = f_{\text{INPUT}}/2$ PR = 4, $f_{\text{COUNTER}} = f_{\text{INPUT}}/4$ PR = 8, $f_{\text{COUNTER}} = f_{\text{INPUT}}/8$ PR = 16, $f_{\text{COUNTER}} = f_{\text{INPUT}}/16$ PR = 32, $f_{\text{COUNTER}} = f_{\text{INPUT}}/32$ PR = 64, $f_{\text{COUNTER}} = f_{\text{INPUT}}/64$ PR = 128, $f_{\text{COUNTER}} = f_{\text{INPUT}}/128$ where $f_{\text{INPUT}} = f_{\text{CPU}}$ by default and $f_{\text{INPUT}} = f_{\text{EXT}}$ for external clock option.
Output Parameters	None
Required Preconditions	PWMART_Init must have been called
Functions called	None
Postconditions	Counter starts running.
See also	PWMART_Init

Notes: To use PWMART as a timebase, use the following procedure:

- Depending upon the time base required, you have to calculate the value of Counter_Data to be loaded in ARR register. This value can be calculated from the following equation:

$$\text{Counter_Data} = \text{Timebase} / \text{Tcounter}$$

where Timebase : time base required by user and Tcounter = 1 / fcounter

OR

- You can use PWMART_OCMP_Timebase function.

Table 108. PWMART_OCMP_Mode

Function Name	PWMART_OCMP_Mode
Function Prototype	Void PWMART_OCMP_Mode(Pwsmart_Compare OCMP,Pwsmart_Output POLARITY,unsigned char Compare_Data)
Behaviour Description	Configures the timer in Output compare mode. You have to call this function more than once to enable several output compares.
Input Parameter 1	PWMART_OCMP_O where O can be 0, 1, 2, Or 3. O= 0, Output Compare register 0 value is compared with counter value. O= 1, Output Compare register 1 value is compared with counter value. O= 2, Output Compare register 2 value is compared with counter value. O= 3, Output Compare register 3 value is compared with counter value.
Input Parameter 2	PWMART_POLARITY_0 Output level is low, for Counter value > Compare_Data Output level is high, for Counter value <= Compare_Data PWMART_POLARITY_1 Output level is high, for Counter value > Compare_Data Output level is low, for Counter value <= Compare_Data
Input Parameter 3	Compare_Data Data to be loaded in DCR register (0x00 to 0xFF).
Output Parameters	None
Required Preconditions	PWMART_Counter_Enable must have been called
Functions called	None
Postconditions	The output compare waveform is obtained on the corresponding PWM pin.
See also	None

Table 109. PWMART_OCMP_Timebase

Function Name	PWMART_OCMP_Timebase
Function Prototype	Void PWMART_OCMP_Timebase(double Tinput,double Time,Pwmart_Clock SELECT_CLK)
Behaviour Description	Sets the output compare to be used as time base interrupt. Interrupt is generated after every fixed (time base) interval, depending upon the value of input parameter 2.
Input Parameter 1	Tinput You have to pass this value in nano-second (ns). $Tinput = 1 / Fcpu$ or $Tinput = 1/ Fext$, in case of external clock.
Input Parameter 2	Time You have to pass this (time base) value in nano-second (ns).
Input Parameter 3	PWMART_CLK_PR where PR can be 1,2,4,8,16,32,64 or 128 PR = 1, $f_{COUNTER} = f_{INPUT}$ PR = 2, $f_{COUNTER} = f_{INPUT}/2$ PR = 4, $f_{COUNTER} = f_{INPUT}/4$ PR = 8, $f_{COUNTER} = f_{INPUT}/8$ PR = 16, $f_{COUNTER} = f_{INPUT}/16$ PR = 32, $f_{COUNTER} = f_{INPUT}/32$ PR = 64, $f_{COUNTER} = f_{INPUT}/64$ PR = 128, $f_{COUNTER} = f_{INPUT}/128$ where $f_{INPUT} = f_{CPU}$ by default and $f_{INPUT} = f_{EXT}$ for external clock option.
Output Parameters	None
Required Preconditions	This function does not support floating clock (such as 5.33MHz).
Functions called	None
Postconditions	1. You must enable the interrupt with instruction 'rim'. 2. Interrupts are generated at the time base you provide.
See also	PWMART_Counter_Enable

Notes: Here are some time base ranges corresponding to the various counter clock frequencies (fcounter):

fcounter=8MHz gives a time base range of [125ns to 31.875µs],
from 1 step to 255 steps (ARR=254 to ARR=0).

counter=4MHz gives a time base range of [250ns to 63.75µs]

fcounter=2MHz gives a time base range of [500ns to 127.5µs]

fcounter=1MHz gives a time base range of [1µs to 255µs]

fcounter=500kHz gives a time base range of [2µs to 510µs]

fcounter=250kHz gives a time base range of [4µs to 1.02ms]

fcounter=125kHz gives a time base range of [8 μ s to 2.04ms]
 fcounter=62.5kHz gives a time base range of [16 μ s to 4.08ms]

Table 110. PWMART_PWM_Mode

Function Name	PWMART_PWM_Mode
Function Prototype	Void PWMART_PWM_Mode(Pwmart_Pwm SELECT_Pin,Pwmart_Output POLARITY,unsigned char Dutycycle_Data)
Behaviour Description	Selection of PWM pin, polarity and duty cycle. You have to call this function more than once to generate several PWM signals.
Input Parameter 1	PWMART_Pin Pin=0 PWM signal on PWM0 port pin. Pin=1 PWM signal on PWM1 port pin. Pin=2 PWM signal on PWM2 port pin. Pin=3 PWM signal on PWM3 port pin.
Input Parameter 2	PWMART_POLARITY_0 PWM output level is low, for Counter value > Dutycycle_Data PWM output level is high, for Counter value <= Dutycycle_Data PWMART_POLARITY_1 PWM output level is high, for Counter value > Dutycycle_Data PWM output level is low, for Counter value <= Dutycycle_Data
Input Parameter 3	Dutycycle_Data Data to be loaded in corresponding OCR register (0x00 to 0xFFh). Note: This value must be greater than the ARR register value loaded through PWMART_Enable function. Refer to the table given below.
Output Parameters	None
Required Preconditions	PWMART_Counter_Enable must have been called
Functions called	None
Postconditions	PWM signal is generated on the selected pin.
See also	None

Note: The table given below shows data to be loaded in ARR register for different PWM signal

frequency and resolution (0x00 to 0xFFh)

ARR value	Resolution	f _{PWM}
0	8-bit	0.244-31.25 KHz
0 -127	> 7-bit	0.244-62.5 KHz
128 -191	> 6-bit	0.488-125 KHz
192 - 223	> 5-bit	0.977-250 KHz
224 - 239	> 4-bit	1.953-500 KHz

Table 111. PWMART_ICAP_Mode

Function Name	PWMART_ICAP_Mode
Function Prototype	Void PWMART_ICAP_Mode(Pwmart_Icap ICAP_I,Pwmart_Sens_IT_Param SENS_IT_Value)
Behaviour Description	Selects the user defined transition on ARTICx pin. This function can be called twice to make use of both ARTICx pins. You can pass one or more parameters from input parameter 2 by Bitwise ORing them together.
Input Parameter 1	PWMART_ICAP_1 Input Capture at ARTIC1 pin is enabled PWMART_ICAP_2 Input Capture at ARTIC2 pin is enabled
Input Parameter 2	PWMART_SENSITIVITY_F Falling edge triggers the capture PWMART_SENSITIVITY_R Rising edge triggers the capture PWMART_ICAP1_IT_ENABLE Enable input capture1 interrupt PWMART_ICAP2_IT_ENABLE Enable input capture2 interrupt
Output Parameters	None
Required Preconditions	1. Function PWMART_Counter_Enable must have been called. 2. The input capture pins used must be configured as floating inputs.
Functions called	None
Postconditions	1. PWMART configured for input capture mode. 2. To detect the occurrence of valid edge, you can poll the input capture flag using the function PWMART_Status_Flag. In this case, you should not enable the input capture interrupt.
See also	PWMART_Status_Flag, PWMART_ICAP_Getvalue

Table 112. PWMART_ICAP_Getvalue

Function Name	PWMART_ICAP_Getvalue
Function Prototype	Unsigned char PWMART_ICAP_Getvalue(Pwmart_Icap ICAP_I)
Behaviour Description	Returns the input capture1 or input capture 2 register value depending upon the input parameter passed. This function should be called twice in order to get both input capture1 and input capture2 register values.
Input Parameters	PWMART_ICAP_I PWMART_ICAP_1 Input capture 1 register value is returned PWMART_ICAP_2 Input capture 2 register value is returned
Output Parameters	Input capture 1 or Input capture 2 register value. The returned value can be in the range of 0x00 to 0xFF.
Required Preconditions	ICF1 and/or ICF2=1 You have to call this function after the ICF1 and/or ICF2 flag is set, to get the capture value.
Functions called	None
Postconditions	1.Input capture1 or Input capture 2 register value is returned. 2.Input capture flag is cleared.
See also	PWMART_ICAP_Mode

Table 113. PWMART_Status_Flag

Function Name	PWMART_Status_Flag
Function Prototype	BOOL PWMART_Status_Flag(Pwmart_Flag FLAG_F)
Behaviour Description	Checks the status of any one of the PWMART flags depending upon the input parameter passed. The function can be called more than once for checking more than one flag.
Input Parameters	PWMART_FLAG_F PWMART_FLAG_ICF1 checks for input capture1 flag PWMART_FLAG_ICF2 checks for input capture 2 flag PWMART_FLAG_OVF checks for overflow flag
Output Parameters	TRUE or FALSE If TRUE : flag is set If FALSE : flag is not set.
Required Preconditions	PWMART must be configured in any one of the mode.
Functions called	None
Postconditions	If the output parameter is TRUE, flag is set and can be cleared by calling PWMART_Clear_Flag, in case of ICF1 and ICF2. In case of OVF, there is no need to call PWMART_Clear_Flag. If the output parameter is FALSE, the flag is not set and this function can be looped until the flag is set.
See also	None

Table 114. PWMART_Clear_Flag

Function Name	PWMART_Clear_Flag
Function Prototype	Void PWMART_Clear_Flag(Pwmart_Flag FLAG_F)
Behaviour Description	Clears the status flag depending upon the input parameter passed. This function can be called more than once to clear more than one flag.
Input Parameters	PWMART_FLAG_F PWMART_FLAG_ICF1 clears the input capture1 f lag PWMART_FLAG_ICF2 clears the input capture 2 flag PWMART_FLAG_OVF clears the overflow flag
Output Parameters	None
Required Preconditions	ICF1=1 or ICF2=1 or OVF=1
Functions called	None
Postconditions	Selected status flag is cleared.
See also	PWMART_Status_Flag

Table 115. PWMART_Mode_Disable

Function Name	PWMART_Mode_Disable
Function Prototype	Void PWMART_Mode_Disable(Pwmart_Dparam MODE)
Behaviour Description	Disables the PWMART mode depending upon Input parameter passed. This function should be called more than once in order to disable more than one functionality
Input Parameters	<p>PWMART_PWM0_DISABLE Disable PWM0 output</p> <p>PWMART_PWM1_DISABLE Disable PWM1 output</p> <p>PWMART_PWM2_DISABLE Disable PWM2 output</p> <p>PWMART_PWM3_DISABLE Disable PWM3 output</p> <p>PWMART_OVF_IT_DISABLE Disable OVF interrupt</p> <p>PWMART_ICAP1_IT_DISABLE Disable ICAP1 interrupt</p> <p>PWMART_ICAP2_IT_DISABLE Disable ICAP2 interrupt</p> <p>PWMART_COUNTER_DISABLE Disable PWMART counter</p>
Output Parameters	None
Required Preconditions	PWMART active in any mode
Functions called	None
Postconditions	Selected PWMART functionality is disabled
See also	None

EXAMPLE:

The following C program shows the use of the PWMART functions.

Program description:

This program detects the event (rising edge) at ARTIC1 pin and generates the PWM signal of frequency 50KHz with duty cycle 33% on the PWM1 pin for ST72F521 device with a 4MHz external clock. The output compare signal is obtained on the PWM2 pin.

```

/* Program start */

#include "ST7lib_config.h" /* Select ST72F521 */

//prototype declaration
void PWMART_IT_Routine(void);
void main(void);

void main(void)
{
    unsigned char Counter_Data = 0xB0;
    unsigned char Compare_Data = 0xCA;
    unsigned char DutyCycle_Data = 0xCA;

    /* ARTIC1,ARTIC2,ARTCLK as floating input */
    IO_Input (IO_FLOATING,IO_PORT_B,((unsigned char)IO_PIN_4 |
        ((unsigned char)IO_PIN_5 | (unsigned char)IO_PIN_6)));
    /* Initialise the timer with external clock frequency
        and overflow interrupt enabled */
    PWMART_Init( ((unsigned char)PWMART_EXCLK |
        (unsigned char)PWMART_OVF_IT_ENABLE));
    /* clear I bit in CC register */
    EnableInterrupts /* Macro defined in st7lib_config.h */
    /* Autoload the counter with ARR */
    PWMART_Counter_Enable(PWMART_REG_ARR,Counter_Data,PWMART_CLK_1);
    /* Output compare signal on PWM2 pin */
    PWMART_OCMP_Mode(PWMART_OCMP_2,PWMART_POLARITY_0,Compare_Data);
    /* To detect rising edge at capture1,capture1 interrupt enable */
    PWMART_ICAP_Mode(PWMART_ICAP_1,((unsigned char)PWMART_SENSITIVITY_R |
        (unsigned char)PWMART_ICAP1_IT_ENABLE));
    /* PWM signal on PWM1 pin */
    PWMART_PWM_Mode(PWMART_1,PWMART_POLARITY_0,DutyCycle_Data);

    while(1); /* For testing only */
}

/* -----
ROUTINE NAME : PWMART_IT_Routine
INPUT      : None
OUTPUT     : None
DESCRIPTION : Interrupt service routine
COMMENTS   : This gets automatically executed when any of the PWMART
              interrupt is enabled. If the same functions are called in the

```

Function Descriptions

main Tree and the interrupt Tree, the function Re-entrant error occurs in case COSMIC compiler is used with models other than stack models.

```
-----*/
#ifdef _HIWARE_                                     /* test for HIWARE Compiler */
#pragma TRAP_PROC SAVE_REGS                         /* additional registers will be saved */
#else
#ifdef _COSMIC_                                     /* test for Cosmic Compiler */
@interrupt
#else
#error "Unsupported Compiler!"                     /* Compiler Defines not found! */
#endif
#endif
void PWMART_IT_Routine(void)
{
    unsigned char CAP1_Value;
    unsigned char i,Temp;

    if(PWMART_Status_Flag(PWMART_FLAG_OVF) == TRUE)
    {
        PWMART_Clear_Flag(PWMART_FLAG_OVF);        /* call only to clear OVF */
    }

    if (PWMART_Status_Flag (PWMART_FLAG_ICF1) == TRUE)
    {
        PWMART_Clear_Flag(PWMART_FLAG_ICF1);      /* call only to clear ICF1 */
                                                /* call to get capture value and also clear ICF1 */
        CAP1_Value = PWMART_ICAP_Getvalue(PWMART_ICAP_1);
                                                /* Routine for user code */
        IO_Output (IO_PUSH_PULL, IO_PORT_C, IO_PIN_0);
        IO_Write (IO_PORT_C, IO_PIN_0, IO_DATA_HIGH);    /* Turn ON LED at PC0 */

        for ( i=0;i<=250;i++)                       /* delay */
        {
            Nop
        }
        IO_Write (IO_PORT_C, IO_PIN_0, IO_DATA_LOW);    /* Turn ON LED at PC0 */
    }
}
```

9.1.10 LITE AUTO-RELOAD TIMER (LART)

This software library consists of the following functions for LART.

Function Name	LART_Init
Function Prototype	Void LART_Init(Lart_InitParameter InitValue)
Behaviour Description	Initialization of the LART, by default counter clock is OFF and interrupts disabled. To change this default configuration, you can pass one or more input parameters by logically ORing them together.
Input Parameter	LART_COUNTER_CLK_FLT sets counter clock = f_{LTIMER} LART_COUNTER_CLK_FCPU sets counter clock = f_{CPU} LART_OVF_IT_ENABLE enables overflow interrupt LART_OCMP_IT_ENABLE enables compare interrupt LART_DEFAULT sets default configuration
Output Parameters	None
Required Preconditions	None
Functions called	None
Postconditions	LART is configured as desired
See also	None

Table 116. LART_Disable

Function Name	LART_Disable
Function Prototype	Void LART_Disable(Lart_Disable_Param DValue)
Behaviour Description	Disables overflow interrupt or compare interrupt or makes counter clock OFF or all of these depending upon the input parameter passed. More than one input parameter can be passed by logically ORing them together.
Input Parameter	<p>LART_OVF_IT_DISABLE disables overflow interrupt</p> <p>LART_OCMP_IT_DISABLE disables compare interrupt</p> <p>LART_COUNTER_CLK_OFF counter clock OFF</p> <p>LART_PWM_DISABLE disables PWM0 output</p> <p>LART_PWM0_DISABLE disables PWM0 output</p> <p>LART_PWM1_DISABLE ¹⁾ disables PWM1 output</p> <p>LART_PWM2_DISABLE ¹⁾ disables PWM2 output</p> <p>LART_PWM3_DISABLE ¹⁾ disables PWM3 output</p> <p>LART_ICAP_IT_DISABLE ¹⁾ disables Input Capture interrupt</p> <p>LART_CTR2_DISABLE ²⁾ disables counter 2, uses counter 1 only</p> <p>LART_OVF2_IT_DISABLE ²⁾ disables counter 2 overflow interrupt</p> <p>LART_LONG_ICAP_DISABLE ²⁾ disables long input capture mode</p>
Output Parameters	None
Required Preconditions	Interrupts enabled or counter clock selected
Functions called	None
Postconditions	Overflow interrupt or compare interrupt or counter clock is OFF depending upon the input parameter passed.
See also	LART_Init

1) Feature available only for ST7FLite1, ST7FLite2, ST7FLite3 and ST7DALI devices.

2) Feature available only on ST7FLite3 device.

Notes: If PWM output is disabled, the Output compare mode is enabled as the OE bit is cleared.

Table 117. LART_PWM_Mode

Function Name	LART_PWM_Mode
Function Prototype	Void LART_PWM_Mode(unsigned int Autoreload_Value, Lart_Output POLARITY, unsigned int Dutycycle_Data)
Behaviour Description	Generates PWM on PWM0 pin. The PWM signal frequency is controlled by the counter clock period and ATR register value. The PWM signal duty cycle depends upon input parameter 1 and input parameter 3. This function is used only for Lite0 device, for other devices use LART_ConfigurePWM.
Input Parameter 1	Autoreload_Value This value is loaded in autoreload register (ATR). You can select this value from 0x000 to 0xFFF depending on the frequency required for the PWM signal.
Input Parameter 2	LART_POLARITY_0 PWM output level is low, for Counter value > Dutycycle_Data, PWM output level is high, for Counter value <= Dutycycle_Data. LART_POLARITY_1 PWM output level is high, for Counter value > Dutycycle_Data, PWM output level is low, for Counter value <= Dutycycle_Data.
Input Parameter 3	Dutycycle_Data Data to be loaded in Duty cycle register (0x000 to 0xFFF). Note: This value must be greater than the ATR register value loaded through Input parameter 1 to obtain signal on PWM0 pin.
Output Parameters	None
Required Preconditions	LART_Init must have been called to select the counter clock.
Functions called	None
Postconditions	PWM signal of required frequency and duty cycle is generated at PWM0 pin. The output compare mode is disabled.
See also	LART_Init, LART_ConfigurePWM

Notes:

- This function can be used only with ST7FLite0 devices.
- This function is used to keep backward compatibility with previous library. For new development LART_ConfigurePWM function should be used with the first parameter LART_PWM0 in place of this function.

Table 118. LART_ConfigurePWM

Function Name	LART_ConfigurePWM
Function Prototype	Void LART_ConfigurePWM (Lart_PWMChannel PWM-Channel, unsigned int Autoreload_Value, Lart_Output POLARITY, unsigned int Dutycycle_Data)
Behaviour Description	Generates PWM on PWMx pin. The PWM signal frequency is controlled by counter clock period and ATR register value (Input parameter 1). The PWM signal duty cycle depends upon input parameter 2 and input parameter 4.
Input Parameter 1	<p>PWMChannel</p> <p>LART_PWM0 PWM channel 0 is configured</p> <p>LART_PWM1 ¹⁾ PWM channel 1 is configured</p> <p>LART_PWM2 ¹⁾ PWM channel 2 is configured</p> <p>LART_PWM3 ¹⁾ PWM channel 3 is configured</p>
Input Parameter 2	<p>Autoreload_Value</p> <p>This value is loaded in autoreload register (ATR). You can select this value from 0x000 to 0xFF F depending on the frequency required for the PWM signal.</p>
Input Parameter 3	<p>LART_POLARITY_0</p> <p>PWM output level is low, for Counter value > Dutycycle_Data, PWM output level is high, for Counter value <= Dutycycle_Data.</p> <p>LART_POLARITY_1</p> <p>PWM output level is high, for Counter value > Dutycycle_Data, PWM output level is low, for Counter value <= Dutycycle_Data.</p>
Input Parameter 4	<p>Dutycycle_Data</p> <p>Data to be loaded in Duty cycle register (0x000 to 0xFF F). Note: This value must be greater than the ATR register value loaded through Input parameter 1 to obtain signal on PWMx pin.</p>
Output Parameters	None
Required Preconditions	LART_Init must have been called to select the counter clock.
Functions called	None

Postconditions	PWM signal of required frequency and duty cycle is generated at PWMx pin. The output compare mode is disabled.
See also	LART_Init

1) Feature available only for ST7FLite1, ST7FLite2, ST7FLite3 and ST7DALI devices.

Note: This function configures only one PWM channel at one time. So to configure multiple PWM Channels this function should be called multiple times.

Table 119. LART_OCMP_Mode

Function Name	LART_OCMP_Mode
Function Prototype	Void LART_OCMP_Mode(unsigned int DutyCycle_Data)
Behaviour Description	Puts timer in Output Compare mode. This mode disables PWM output. This function is used for ST7FLite0 only, for other devices LART_ConfigureOCMP should be used
Input Parameter	DutyCycle_Data Data to be loaded in Duty cycle register (0x000 to 0xFFFF) which will be compared with upcounter.
Output Parameters	None
Required Preconditions	LART_Init must have been called to select the counter clock.
Functions called	None
Postconditions	When the upcounter value reaches the DutyCycle_Data, the CMPFxf flag is set and an interrupt is generated if compare interrupt is enabled.
See also	LART_Init

Notes:

- This function can be used only with the ST7FLite0 device.
- This function is added for backward compatibility with previous library. For new developments LART_ConfigurePWM should be used with LART_OCMP0 as the first parameter.

Table 120. LART_ConfigureOCMP

Function Name	LART_ConfigureOCMP
Function Prototype	Void LART_ConfigureOCMP(Lart_OCMPChannel OCM- PChannel, unsigned int Dutycycle_Data)
Behaviour Description	Puts timer in Output Compare mode. This mode disables PWM output.
Input Parameter 1	OCMPChannel LART_OCMP0 OCMP0 is configured LART_OCMP1 ¹⁾ OCMP1 is configured LART_OCMP2 ¹⁾ OCMP2 is configured LART_OCMP3 ¹⁾ OCMP3 is configured
Input Parameter 2	Dutycycle_Data Data to be loaded in Duty cycle register (0x000 to 0xFFFF) which will be compared with upcounter.
Output Parameters	None
Required Preconditions	LART_Init must have been called to select the counter clock.
Functions called	None
Postconditions	When the upcounter value reaches the Dutycycle_Data, the CMPFxf flag is set and an interrupt is generated if com- pare interrupt is enabled.
See also	LART_Init, LART_OCMP_Mode

1) Feature available only for ST7FLite1, ST7FLite2, ST7FLite3 and ST7DALI devices

Note: Take care of the ATR value while using this function.

Table 121. LART_Status_Flag

Function Name	LART_Status_Flag
Function Prototype	BOOL LART_Status_Flag(Lart_Flag FLAG_F)
Behaviour Description	Checks the status of any one of the LART flags depending upon the input parameter passed. The function can be called more than once for checking more than one flag.
Input Parameters	FLAG_F LART_FLAG_OVF Checks Overflow flag LART_FLAG_CMPF0 Checks Output Compare 0 flag LART_FLAG_CMPF1 ¹⁾ Checks Output Compare 1 flag LART_FLAG_CMPF2 ¹⁾ Checks Output Compare 2 flag LART_FLAG_CMPF3 ¹⁾ Checks Output Compare 3 flag LART_FLAG_ICF ¹⁾ Checks Input Capture flag LART_FLAG_OVF2 ²⁾ Checks counter 2 overflow flag
Output Parameters	TRUE or FALSE If TRUE: flag is set If FALSE: flag is not set.
Required Preconditions	LART configured in any one of the modes.
Functions called	None
Postconditions	If the output parameter is TRUE, flag is set. If the output parameter is FALSE, the flag is not set and this function can be looped till the flag is set. LART_Clear_Flag function should be called to clear the flag.
See also	LART_Clear_Flag

1) Feature available only for ST7FLite1, ST7FLite2, ST7FLite3 and ST7DALI devices.

2) Feature available only on ST7FLite3 device.

Note: All flags except **LART_FLAG_ICF** also get cleared by calling this function so need to call LART_Clear_Flag function again to clear the flag.

Table 122. LART_Clear_Flag

Function Name	LART_Clear_Flag
Function Prototype	Void LART_Clear_Flag(Lart_Flag FLAG_F)
Behaviour Description	Clears the status flag depending upon the input parameter passed. This function can be called more than once to clear more than one flag.
Input Parameters	<p>FLAG_F</p> <p>LART_FLAG_OVF Clears Overflow flag</p> <p>LART_FLAG_CMPF0 Clears Output Compare 0 flag</p> <p>LART_FLAG_CMPF1¹⁾ Clears Output Compare 1 flag</p> <p>LART_FLAG_CMPF2¹⁾ Clears Output Compare 2 flag</p> <p>LART_FLAG_CMPF3¹⁾ Clears Output Compare 3 flag</p> <p>LART_FLAG_ICF¹⁾ Clears Input Capture flag</p> <p>LART_FLAG_OVF2²⁾ Clears counter 2 overflow flag</p>
Output Parameters	None
Required Preconditions	Any of LART flags is set
Functions called	None
Postconditions	Selected status flag is cleared.
See also	LART_Status_Flag

1) Feature available only for ST7FLite1, ST7FLite2, ST7FLite3 and ST7DALI devices.

2) Feature available only on ST7FLite3 device.

Table 123. LART_ICAPMode

Function Name	LART_ICAPMode
Function Prototype	Void LART_ICAPMode(Lart_ICAPInitParams InitParams)
Behaviour Description	Configures the input Capture mode. This function also enables Input capture interrupt if LART_ICAP_IT_ENABLE is passed as user parameter. This function clears the input capture flag.
Input Parameter	InitParams LART_ICAP_DEFAULT Input capture function is used in polled mode LART_ICAP_IT_ENABLE Input Capture Interrupt is enabled
Output Parameters	None
Required Preconditions	LART_Init must have been called to select the counter clock.
Functions called	None
Postconditions	Poll Input Capture flag or wait for interrupt to read the Input Capture value
See also	LART_ICAPGetValue

Note: This function is available only for ST7FLite1, ST7FLite2, ST7FLite3 and ST7DALI devices.

Table 124. LART_ICAPGetValue

Function Name	LART_ICAPGetValue
Function Prototype	Unsigned int LART_ICAPGetValue()
Behaviour Description	Reads the 12-bit Input capture register value
Input Parameter	None
Output Parameters	Returns the 12-bit input capture register value
Required Preconditions	LART_ICAPMode must have been called. This function should be called only after Input Capture flag is set (flag is checked either by polling or by enabling Input capture interrupt)
Functions called	None
Postconditions	None
See also	LART_ICAPMode

Note: This function is available only for ST7FLite1, ST7FLite2, ST7FLite3 and ST7DALI devices.

Table 125. LART_ConfigureBREAK

Function Name	LART_ConfigureBREAK
Function Prototype	Void LART_ConfigureBREAK (Lart_BREAKPinState BREAKPinState, Lart_BREAK_PWMPattern PWMPat-tern);
Behaviour Description	This function enables/disables the BREAK pin function and loads the PWM bit pattern to be generated in BREAK state
Input Parameter	<p>BREAKPinState:</p> <p>LART_BREAK_ENABLE Enables BREAK Pin (Break condition will be generated by applying low signal to BREAK)</p> <p>LART_BREAK_DISABLE Disables BREAK Pin (Break condition generated by software)</p> <p>PWMPattern: Pattern to be generated on PWM pins. Following parameters are passed as input. These parameters can be logically ORed to pass multiple parameters.</p> <p>LART_BREAK_PWM0_HIGH LART_BREAK_PWM0_LOW LART_BREAK_PWM1_HIGH LART_BREAK_PWM1_LOW LART_BREAK_PWM2_HIGH LART_BREAK_PWM2_LOW LART_BREAK_PWM3_HIGH LART_BREAK_PWM3_LOW</p>
Output Parameters	None
Required Preconditions	None
Functions called	None
Postconditions	If LART_BREAK_DISABLE mode is selected then LART_ActivateBREAK and LART_DeactivateBREAK functions are called to activate and deactivate the BREAK condition.
See also	LART_ActivateBREAK LART_DeactivateBREAK

Note: This function is available only for ST7FLite1, ST7FLite2, ST7FLite3 and ST7DALI devices.

Table 126. LART_ActivateBREAK

Function Name	LART_ActivateBREAK
Function Prototype	Void LART_ActivateBREAK()
Behaviour Description	Generates the software BREAK condition. Break pattern is loaded on PWMx pins.
Input Parameter	None
Output Parameters	None
Required Preconditions	Break state PWM pattern is loaded using function LART_ConfigureBREAK.
Functions called	None
Postconditions	LART_DeactivateBREAK must have been called to deactivate the BREAK condition.
See also	LART_ConfigureBREAK LART_DeactivateBREAK

Note: This function is available only for ST7FLite1, ST7FLite2, ST7FLite3 and ST7DALI devices.

Table 127. LART_DeactivateBREAK

Function Name	LART_DeactivateBREAK
Function Prototype	Void LART_DeactivateBREAK()
Behaviour Description	Deactivates the the software BREAK condition. All LART registers are initialized to reset state.
Input Parameter	None
Output Parameters	None
Required Preconditions	Software BREAK is generated using LART_ActivateBREAK function
Functions called	None
Postconditions	All registers are initialized to Reset state. So Init and other function required to configure the required LART functionality must be called again.
See also	LART_ConfigureBREAK LART_ActivateBREAK

Note: This function is available only for ST7FLite1, ST7FLite2, ST7FLite3 and ST7DALI devices.

Table 128. LART_Counter2Init

Function Name	LART_Counter2Init
Function Prototype	Void LART_Counter2Init(Lart_CTR2InitParams InitParams, unsigned int ATR2Value);
Behaviour Description	This function enables counter 2 which is used for PWM2, PWM3 and loads the autoreload register for counter 2. This also enables counter 2 overflow interrupt depending upon the input parameters passed.
Input Parameter	InitParams: LART_CTR2_OVF_IT_ENABLE Enables counter 2 overflow interrupt LART_CTR2_OVF_IT_DISABLE Disables counter 2 overflow interrupt ATR2Value: Value to be loaded in Autoreload register 2 which is used for counter 2.
Output Parameters	None
Required Preconditions	None
Functions called	None
Postconditions	Counter 2 is configured for PWM2 and PWM3
See also	LART_Disable

Note: This function is available only for the ST7FLite3 device.

Table 129. LART_ReloadATR

Function Name	LART_ReloadATR
Function Prototype	Void LART_ReloadATR(unsigned int AutoReloadVal)
Behaviour Description	This function reloads the autoreload counter. This is used for generating overflow condition and to customize the API usage
Input Parameter	AutoReloadVal: 12-Bit value for auto reload register.
Output Parameters	None
Required Preconditions	None
Functions called	None
Postconditions	Auto reload register is loaded with AutoReloadVal
See also	LART_ConfigurePWM

Table 130. LART_LongICAPMode

Function Name	LART_LongICAPMode
Function Prototype	Void LART_LongICAPMode(Lart_LongICAPInitParams InitParams);
Behaviour Description	Enables the long input capture function of LART. This function selects the clock source as LiteTimer output, Input capture source as LiteTimer input capture and interrupt source as specified in InitParams.
Input Parameter	InitParams: LART_SELF_ICAP_IT_ENABLE Enables LART Input Capture interrupt LART_LT_ICAP_IT_ENABLE Enables Lite Timer Input Capture interrupt LART_ICAP_NO_IT_ENABLE No Input Capture interrupt is enabled
Output Parameters	None
Required Preconditions	None
Functions called	None
Postconditions	Clock source for LART is selected as LiteTimer output and LiteTimer Input capture is used as input capture source. LART_LongICAPGetValue is used to read values when input capture event occurs.
See also	LART_LongICAPGetValue

Notes:

- This function is available only for the ST7FLite3 device.
- This function may affect other functions as it changes the clock source which will also affect the LiteTimer Input capture functionality because this is used along with LART Input Capture for this mode.

Table 131. LART_LongICAPGetValue

Function Name	LART_LongICAPGetValue
Function Prototype	Void LART_LongICAPGetValue(unsigned char *LTValue, unsigned int *LARTValue)
Behaviour Description	Enables the long input capture function of LART. This function selects clock source as LiteTimer output, Input capture source as LiteTimer input capture and interrupt source as specified in InitParams.
Input Parameter	None. Parameters are passed as reference to get the output results.
Output Parameters	LTValue: Value of LiteTimer Input Capture register LARTValue: Value of LART Input Capture register
Required Preconditions	LART_LongICAPMode should be called to configure long Input Capture mode. Input Capture event must occur before this function call.
Functions called	None
Postconditions	Input capture flags of LiteTimer and LART are cleared
See also	LART_LongICAPGetValue

Note: This function is available only for the ST7FLite3 device.

Table 132. LART_GenerateDeadTime

Function Name	LART_GenerateDeadTime
Function Prototype	Void LART_GenerateDeadTime(unsigned char DTValue)
Behaviour Description	This function generates a dead time between PWM0 and PWM1. This is required for Half bridge driving.
Input Parameter	DTValue: 7 Bit value for dead time to be inserted between PWM0 and PWM1. dead time = DTValue * TCounter
Output Parameters	None
Required Preconditions	PWM0 and PWM1 are configured by calling LART_PWM_Mode. Half bridge driving is possible only if Polarities of PWM0 and PWM1 are not inverted otherwise overlapping signal will be generated
Functions called	None
Postconditions	Dead time is inserted between PWM0 and PWM1 signals
See also	LART_PWM_Mode

Note: This function is available only for the ST7FLite3 device.

EXAMPLE:The following C program shows the use of the LART functions.

Program description:

This program generates a PWM signal with a 10KHz frequency and with a 30% Duty cycle and toggles an LED every second (Fcpu=8MHz).

```

/* Program start */

#include "ST7lib_config.h"                                /* Select ST7FLITE0 */

/* prototype declaration */
void LART_OVF_IT_Routine(void);
void main(void);

static unsigned int count;

void main(void)
{

    IO_Output(IO_PUSH_PULL, IO_PORT_B, IO_PIN_3);        /* Port PB3 as pushpull output */
    /* Select Fcpu as counter clock & enable overflow interrupts */
    LART_Init( ((unsigned char)LART_COUNTER_CLK_FCPU |
                (unsigned char)LART_OVF_IT_ENABLE ));      /* Clear I bit in CC register */

    EnableInterrupts
    /* Load ATR and DCR to get PWM signal of 10 KHz and duty cycle of 30% */
    /* Generate PWM at PWM0 pin */
    LART_PWM_Mode((unsigned int)0xCE0, LART_POLARITY_0, (unsigned int)0xDD0);

    while(1);
}

/* -----
ROUTINE NAME : LART_OVF_IT_Routine
INPUT       : None
OUTPUT      : None
DESCRIPTION : Interrupt service routine for Overflow interrupt
COMMENTS    : This gets automatically executed when OVF interrupt of the
              LART is enabled. If the same functions are called in the
              main Tree and the interrupt Tree, the function Re-entrant error
              occurs in case COSMIC compiler is used with models other than
              stack models.
              For configuring the port pins, I/O library is used.
-----*/

#ifdef _HIWARE_                                           /* Test for Metrowerks Compiler */
#pragma TRAP_PROC SAVE_REGS                               /* Additional registers will be saved */
#else
#ifdef _COSMIC_                                           /* Test for Cosmic Compiler */
@interrupt @nostack
#else
#error "Unsupported Compiler!"                             /* Compiler Defines not found! */
#endif
#endif

```

Function Descriptions

```
void LART_OVF_IT_Routine(void)
{
    unsigned char Temp;

    LART_Clear_Flag(LART_FLAG_OVF);           /* Call to clear OVF */
    count++;
    if(count == 10000)
    {
        Temp = IO_Read (IO_PORT_B );        /* TO Toggle PB3 */
        if (Temp & 0x08)
        {
            IO_Write (IO_PORT_B, IO_PIN_3, IO_DATA_LOW); /* Turn OFF LED at PB3 */
        }
        else
        {
            IO_Write (IO_PORT_B, IO_PIN_3, IO_DATA_HIGH); /* Turn ON LED at PB3 */
        }
        count = 0;
    }
}
```

9.1.11 TBU

This software library consists of the following functions for TBU.

Function Name	TBU_Init
Function Prototype	Void TBU_Init (TBU_Init_Param init_value)
Behaviour Description	Initialization of the TBU, sets by default TBU counter frozen, cascading disabled, interrupt disabled and prescaling factor to 2. You can change the default configuration by selecting one or more of the following input parameters.
Input Parameters	TBU_DEFAULT Sets TBU to reset value TBU_ART_CASCADE Cascade the TBU and the PWMART timer counters together TBU_IT_ENABLE TBU overflow interrupt enable
Output Parameters	None
Required Preconditions	None
Functions called	None
Postconditions	None
See also	None

Table 133. TBU_SetPrescCount8

Function Name	TBU_SetPrescCount8
Function Prototype	Void TBU_SetPrescCount 8(TBU_Presc TBU_Prescvalue_P, unsigned char Counter_Value)
Behaviour Description	Selects the prescaler division factor, sets the counter value
Input Parameter 1	TBU_Prescvalue_P where P is the prescaler division factor and it can be 2, 4, 8, 16, 32, 64, 128, 256.
Input Parameter 2	Counter_Value 8 bit counter value. This value can be from 0x00- 0xFFh.
Output Parameters	None
Required Preconditions	1. TBU_Init must have been called. 2. You have to calculate the values Prescvalue_P and Counter_Value for the required delay.
Functions called	None
Postconditions	None
See also	TBU_SetPrescCount16

Table 134. TBU_SetPrescCount16

Function Name	TBU_SetPrescCount16
Function Prototype	Void TBU_SetPrescCount16 (TBU_CasPresc TBU_CasPrescvalue_P, unsigned int Counter_Value)
Behaviour Description	Selects the prescalar value for the PWMART timer and the counter values to be loaded into the TBU and ART registers. ART counter is enabled.
Input Parameters	TBU_CasPrescvalue_P where P is the prescalar division factor and it can be 1, 2, 4, 8, 16, 32, 64, 128.
Input Parameters	Counter_value 16 bit counter value. This value can be from 0000 to FFFFh.
Output Parameters	None
Required Preconditions	<ol style="list-style-type: none"> 1. TBU_Init must have been called. 2. Cascaded mode must be selected 3. You must calculate the TBU_CasPrescValue_P and Counter_Value for the required delay.
Functions called	TBU_Enable must be called immediately after this function to get more accurate delay.
Postconditions	None
See also	TBU_SetPrescCount8

Notes:

- The actual delay obtained using this function will be approximately equal to the calculated delay.
- For best accuracy and smaller delays, it is recommended to use the TBU_SetPrescCount8 function.

Table 135. TBU_Enable

Function Name	TBU_Enable
Function Prototype	Void TBU_Enable(void)
Behaviour Description	TBU is enabled and TBU counter starts running.
Input Parameters	None
Output Parameters	None
Required Preconditions	TBU_SetPrescCount8 or TBU_SetPrescCount16 must have been called.
Functions called	None
Postconditions	If the TBU interrupt is enabled, the control goes into the Interrupt subroutine after the programmed delay time.
See also	None

Table 136. TBU_ReadCounter

Function Name	TBU_ReadCounter
Function Prototype	Unsigned char TBU_ReadCounter (void)
Behaviour Description	Reads the counter register of TBU and returns its current status.
Input Parameters	None
Output Parameters	Unsigned char Value of the counter register
Required Preconditions	None
Functions called	None
Postconditions	None
See also	None

Table 137. TBU_Disable_IT

Function Name	TBU_Disable_IT
Function Prototype	Void TBU_Disable_IT (void)
Behaviour Description	Disables the Overflow interrupt
Input Parameters	None
Output Parameters	None
Required Preconditions	None
Functions called	None
Postconditions	None
See also	TBU_Init

Table 138. TBU_ClearOverflow

Function Name	TBU_ClearOverflow
Function Prototype	Void TBU_ClearOverflow (void)
Behaviour Description	Clears the overflow status flag
Input Parameters	None
Output Parameters	None
Required Preconditions	TBU_Enable must have been called.
Functions called	None
Postconditions	None
See also	TBU_Enable

Table 139. TBU_Disable

Function Name	TBU_Disable
Function Prototype	Void TBU_Disable (void)
Behaviour Description	Disables the TBU counter and prescaler.
Input Parameters	None
Output Parameters	None
Required Preconditions	None
Functions called	None
Postconditions	None
See also	TBU_Enable

Example

The following C program shows the use of the TBU functions.

Program description:

This program is for an ST2F62 device. It generates an interrupt after 1ms if the TBU_Standalone label is selected in ST7lib_config.h file or generates an interrupt after 1s if TBU_Cascade label is selected in ST7lib_config.h file. Also an interrupt subroutine is written which clears the interrupt flag.

```

.  

/***** Program Start *****/  

/* example code for tbu ST72F62 device */  

#include "ST7lib_config.h" /*Configuration File*/  

#define TBU_Standalone

```

```

void TBU_IT_Routine(void);
void main(void);

void main (void)
{
    unsigned char Counter_Value8 = 224;
    unsigned int Counter_Value16 = 10330;
    unsigned char counter;                                /*Variable declaration*/

    EnableInterrupts                                    /*Reset the interrupt mask*/
/*-----
For Stand alone mode
-----*/
#ifdef TBU_Standalone                                  /*Selects Standalone mode*/

    TBU_Init (TBU_DEFAULT+TBU_IT_ENABLE);              /*Enable overflow interrupt*/
    TBU_SetPrescCount8 (TBU_Prescvalue_256,Counter_Value8); /*Generates Interrupt
                                                                after 1ms*/
    counter = TBU_ReadCounter();                        /*Reads the value of counter*/

/*-----
For Cascade Mode
-----*/
#else
#ifdef TBU_Cascade                                    /*Selects Cascade mode*/

    TBU_Init (TBU_IT_ENABLE+TBU_ART_CASCADE);          /*Enable interrupt and select Cascade mode*/
    TBU_SetPrescCount16 (TBU_CasPrescvalue_128,Counter_Value16); /*Generate an interrupt after 1 second */

#endif
#endif
    TBU_Enable();                                     /*Enable the TBU counter*/
    while(1);
}

/*****Interrupt Subroutine*****/

#ifdef _HIWARE_                                       /* test for HIWARE Compiler */
#pragma TRAP_PROC SAVE_REGS                          /* Additional registers will be saved */
#else
#ifdef _COSMIC_                                       /* Test for Cosmic Compiler */
@interrupt                                          /* Cosmic interrupt handling */
#else
#error "Unsupported Compiler!"                       /* Compiler Defines not found! */
#endif
#endif

void TBU_IT_Routine(void)
{
    TBU_ClearOverflow();                              /*Clears the Overflow flag*/
}

```

9.1.12 WDG

Table 140. WDG_Refresh

Function Name	WDG_Refresh
Function Prototype	Void WDG_Refresh (unsigned char Counter_Data)
Behaviour Description	Loads the value of Watchdog counter and activates the Watchdog.
Input Parameter	<p>Counter_Data</p> <p>Value which is loaded in the Watchdog counter. This value must be between 0x40 and 0x7f to avoid an immediate reset.</p> <p>To get an immediate reset this value can be between 0x00 to 0x3f.</p>
Output Parameter	None
Required Preconditions	You must precalculate the value of Counter_Data for the desired Watchdog timeout.
Functions called	None
Postconditions	<ol style="list-style-type: none"> 1. The Watchdog is activated after this function and can not be disabled, except by a reset. 2. A Reset is generated after the desired Timeout, when Watchdog counter rolls over from 0x40 to 0x3f (See Table 141 for some Counter_Data values and corresponding Watchdog Timeout). 3. For window watchdog, a reset is also generated if this routine is called when the Watchdog counter value is greater than the Window register value ¹⁾.

1) This condition is valid only for Window Watchdog

Notes:

- This function takes less ROM area but you must pass a precalculated Watchdog counter value.
- To prevent the Watchdog reset this routine must be called when:
 1. The Watchdog counter value is greater than 0x3F
 2. and lower than the Window register for Window Watchdog.
- The Watchdog for the ST7FLITE0 device is integrated with the Lite Timer peripheral.
- Functions for that watchdog are integrated with the Lite Timer library functions.

Table 141. Watchdog Timeout for some Counter_Data values at fosc2 = 8MHz for ST72F521 device

Counter_Data	Watchdog Timeout (ms)
0x3f to 0x00	0.0
0x40	1.5
0x50	34
0x60	65
0x70	98
0x7f	128

Table 142. WDG_ComputeTimeout

Function Name	WDG_ComputeTimeout
Function Prototype	Void WDG_ComputeTimeout (unsigned long WDG_Timeout)
Behaviour Description	Sets the value of Watchdog counter as per the selected Timeout and activates the watchdog.
Input Parameter	WDG_Timeout Required Watchdog Timeout. This value must be entered in microseconds.
Output Parameter	None
Required Preconditions	You must define Fcpu and Fosc2 in ST7lib_config.h correctly.
Functions called	None
Postconditions	<p>1. The Watchdog is activated after this function and can not be disabled, except by a reset.</p> <p>2. A Reset is generated after a time approximately equal to WDG_Timeout (If the Watchdog counter is not changed in between)</p> <p>3. For window watchdog a reset is generated, also if this routine is called when the Watchdog counter value is greater than the Window register value ¹⁾</p>

1) This condition is valid only for Window Watchdog

Notes:

- This function will give the approximate Timeout. For more accurate results you must do the calculations as per the formulas given in the datasheet and call the previous function for loading counter value.
- If the selected Watchdog Timeout is not possible, you will get the next possible value
- To prevent the Watchdog reset this routine must be called when the Watchdog counter value.:
 1. is greater than 0x3F
 2. and lower than the Window register for Window Watchdog

Table 143. WDG_ReadCounter

Function Name	WDG_ReadCounter
Function Prototype	Unsigned char WDG_ReadCounter (void)
Behaviour Description	Returns the WDG counter register value
Input Parameter	None
Output Parameter	WDG counter register value
Required Preconditions	None
Functions called	None
Postconditions	None

Table 144. WDG_ReadWindow

Function Name	WDG_ReadWindow
Function Prototype	Unsigned char WDG_ReadWindow (void)
Behaviour Description	Returns the value of the window register
Input Parameter	None
Output Parameter	Window register value
Required Preconditions	None
Functions called	None
Postconditions	None

Caution: This function is valid only for Window Watchdog, if used for normal Watchdog a compilation error is generated.

Table 145. WDG_WriteWindow

Function Name	WDG_WriteWindow
Function Prototype	Void WDG_WriteWindow (unsigned char)
Behaviour Description	Loads the value of the window register which is compared with the watchdog counter
Input Parameter	Value to be loaded in the Window register. This value must be between 0x00 and 0x7F
Output Parameter	None
Required Preconditions	None
Functions called	None
Postconditions	After this function, Watchdog counter value is compared with the new window value. If watchdog counter is reloaded outside this window value, a watchdog reset is generated.

Caution: This function is valid only for Window Watchdog, if used for normal Watchdog a compilation error is generated.

EXAMPLE:

The following C program shows the use of the WDG library functions.

Program description:

This program generates the watchdog reset for ST72F521 device. The reset timeout period is configured as 34ms with fosc2 = 8MHz, through function WDG_Refresh with input parameter "Counter_Data" as 0x50 (See [Table 141](#)).

Watchdog reset timeout can also be configured through WDG_ComputeTimeout function (refer to the example below). Here it is configured for a reset timeout of 20,000µs with input parameter WDG_Timeout given as 20,000.

In Window Watchdog, the reset can be generated by reloading the WDG counter register outside the Window. In the example it is generated after 1ms

```

/***** Program Start *****/
#include "ST7lib_config.h"

void main(void);
void main (void)
{
    unsigned int i;
    /*-----
    WDG_Refresh function to generate a reset after 34ms at fosc2 = 8MHz
    -----*/

    WDG_Refresh (0x50);                               /*Generates reset after 34ms*/

    /*-----
    WDG_ComputeTimeout function to generate a reset after 20ms (MCC timebase:
    4ms, fosc2 = 8MHz)
    -----*/
    /*WDG_ComputeTimeout (50000); */                  /*Generates reset after 20ms*/

    /*-----
    Window Watchdog for setting a Refresh Period of 34ms and a Window Size of
    18.432ms at fosc2 = 8MHz. Reset is generated after 1ms by reloading the WDG
    counter register outside the window.
    -----*/

    #ifdef WDG_72F561
    WDG_Refresh(0x50) ;                               /* Set a Refresh period of 34ms */
    WDG_WriteWindow(0x48)
    for (i = 0; i < 532; i++) ;                       /*1ms delay */
    WDG_Refresh(0x50);                               /* Generates Reset on execution of this routine */
    #endif

    while (1);
}

```

9.1.13 ITC

Table 146. ITC_Init

Function Name	ITC_Init
Function Prototype	Void ITC_Init (void)
Behaviour Description	Initializes all the Interrupt software priority registers and External interrupt controller/status register to their default values.
Input Parameters	None
Output Parameters	None
Required Preconditions	None
Functions called	None
Postconditions	None
See also	None

Table 147. ITC_SetPriority

Function Name	ITC_SetPriority
Function Prototype	Void ITC_SetPriority (ITC_IT IT, ITC_LEVEL Level)
Behaviour Description	Sets the Interrupt software Priority levels of the selected interrupts
Input Parameter 1	<p>IT_MCC Sets the software priority of MCC interrupt</p> <p>IT_EI0 Sets the software priority of External interrupt0</p> <p>IT_EI1 Sets the software priority of External interrupt1</p> <p>IT_EI2 Sets the software priority of External interrupt2</p> <p>IT_EI3 Sets the software priority of External interrupt3</p> <p>IT_CAN Sets the software priority of CAN peripheral interrupt</p> <p>IT_SPI Sets the software priority of SPI peripheral interrupt</p> <p>IT_TIMERA ²⁾ Sets the software priority of TIMERA peripheral interrupt</p> <p>IT_TIMERB ²⁾ Sets the software priority of TIMERB peripheral interrupt</p> <p>IT_SCI ²⁾ Sets the software priority of SCI peripheral interrupt</p>

Input Parameter 1	<p>IT_AVD Sets the software priority of Auxiliary Voltage detector interrupt</p> <p>IT_I2C ²⁾ Sets the software priority of I2C peripheral interrupt</p> <p>IT_PWMART Sets the software priority of PWMART peripheral interrupt</p> <p>IT_DTC ²⁾ Sets the software priority of DTC peripheral interrupt</p> <p>IT_PLG Sets the software priority of Power Management USB plug/unplug interrupt</p> <p>IT_ESUSP Sets the software priority of USB Endsuspend interrupt</p> <p>IT_USB ²⁾ Sets the software priority of USB peripheral interrupt</p> <p>IT_TIM Sets the software priority of TIMER interrupt</p> <p>IT_ADC Sets the software priority of A/D End of Conversion Interrupt</p> <p>IT_CSS Sets the software priority of Clock Filter Interrupt</p> <p>IT_SCI1,IT_SCI2 Sets the software priority of SCI interrupts</p>
Input Parameter 2 ¹⁾	<p>IT_LEVEL_1 Sets the priority of the selected interrupt as Level1</p> <p>IT_LEVEL_2 Sets the priority of the selected interrupt as Level2</p> <p>IT_LEVEL_3 Sets the priority of the selected interrupt as Level3</p>
Output Parameter	None
Required Preconditions	None
Functions called	None
Postconditions	None
See also	None

1) IT_LEVEL_0 can not be written.

2) These Interrupts do not have an Exit from HALT mode capability.

Notes:

- This function is for ST72F521,ST72F561,ST72F65,ST72F62,ST72F264, ST72325 and ST7232A devices.

- For selecting different priorities for different interrupts you must call the function more than once. If it is required to set two or more interrupts to same priority level, then you can pass them together by logically ORing.
- This function is for Nested Interrupts only.

Caution:

- If you select an interrupt which is not present in the Peripheral then you will get an error message during compilation.
- If the Priority of the Interrupt is changed while it is being executed then the following behaviour has to be considered:
If that interrupt is still pending, and the new software priority is higher than the previous one, the interrupt is re-entered. Otherwise the software priority stays unchanged until the next interrupt request.

Table 148. ITC_Get_CurrentLevel

Function Name	ITC_Get_CurrentLevel
Function Prototype	ITC_LEVEL ITC_Get_CurrentLevel (void)
Behaviour Description	Returns the Interrupt software priority level of the current Interrupt.
Input Parameters	None
Output Parameters	IT_LEVEL_0 Software Priority of the current interrupt is at Level0 IT_LEVEL_1 Software Priority of the current interrupt is at Level1 IT_LEVEL_2 Software Priority of the current interrupt is at Level2 IT_LEVEL_3 Software Priority of the current interrupt is at Level3
Required Preconditions	None
Functions called	None
Postconditions	None
See also	None

Note: This function is for ST72F521,ST72F561,ST72F65,ST72F62,ST72F264, ST72325 and ST7232A devices.

Table 149. ITC_GetPriority

Function Name	ITC_GetPriority
Function Prototype	ITC_LEVEL ITC_GetPriority (ITC_IT IT)
Behaviour Description	Returns the software priority level of the selected interrupt.
Input Parameter 1	<p>IT_MCC Returns the software priority of MCC interrupt</p> <p>IT_EI0 Returns the software priority of External interrupt0</p> <p>IT_EI1 Returns the software priority of External interrupt1</p> <p>IT_EI2 Returns the software priority of External interrupt2</p> <p>IT_EI3 Returns the software priority of External interrupt3</p> <p>IT_CAN Returns the software priority of CAN peripheral interrupt</p> <p>IT_SPI Returns the software priority of SPI peripheral interrupt</p> <p>IT_TIMER A Returns the software priority of TIMER A peripheral interrupt</p> <p>IT_TIMER B Returns the software priority of TIMERB peripheral interrupt</p> <p>IT_SCI Returns the software priority of SCI peripheral interrupt</p> <p>IT_AVD Returns the software priority of Auxiliary Voltage detector interrupt</p>

<p>Input Parameter 1</p>	<p>IT_I2C Returns the software priority of I2C peripheral interrupt</p> <p>IT_PWMART Returns the software priority of PWMART peripheral interrupt</p> <p>IT_DTC Returns the software priority of DTC interrupt</p> <p>IT_PLG Returns the software priority of Power Management USB plug/unplug interrupt</p> <p>IT_ESUSP Returns the software priority of USB Endsuspend interrupt</p> <p>IT_USB Returns the software priority of USB peripheral interrupt</p> <p>IT_TIM Returns the software priority of TIMER interrupt</p> <p>IT_ADC Returns the software priority of A/D End of Conversion interrupt</p> <p>IT_CSS Returns the software priority of Clock Filter interrupt</p> <p>IT_SCI1,IT_SCI2 Returns the software priority of SCI interrupts</p>
<p>Output Parameter</p>	<p>IT_LEVEL_0 Priority of the selected interrupt is at Level0</p> <p>IT_LEVEL_1 Priority of the selected interrupt is at Level1</p> <p>IT_LEVEL_2 Priority of the selected interrupt is at Level2</p> <p>IT_LEVEL_3 Priority of the selected interrupt is at Level3</p>
<p>Required Preconditions</p>	<p>None</p>
<p>Functions called</p>	<p>None</p>
<p>Postconditions</p>	<p>None</p>
<p>See also</p>	<p>None</p>

Notes:

- This function is for ST72F521,ST72F561,ST72F65,ST72F62,ST72F264, ST72325 and ST7232A devices.
- This function is for Nested Interrupts only.

Caution: If you select an interrupt which is not present in the Peripheral then he will get an error message during compilation.

Table 150. ITC_TRAP

Function Name	ITC_TRAP
Function Prototype	Void ITC_TRAP (void)
Behaviour Description	Generates TRAP interrupt.
Input Parameters	None
Output Parameters	None
Required Preconditions	None
Functions called	None
Postconditions	None
See also	None

Note: This is a Non Maskable Software Interrupt and can interrupt a Level3 program.

Table 151. ITC_ConfigureInterrupt

Function Name	ITC_ConfigureInterrupt
Function Prototype	Void ITC_ConfigureInterrupt(ITC_Port Portx, unsigned char Pin, ITC_Sensitivity Sensitivity)
Behaviour Description	Enables the interrupts and also Sets the Interrupt sensitivity of the selected Port pin.
Input Parameter 1	IT_Portx x = A, B,C,D, E,F
Input Parameter 2	Pin This value must be between 0 to 7
Input Parameter 3	IT_EDGE_F_0 Sets the interrupt sensitivity of the selected pin as falling edge and Low level. IT_EDGE_R Sets the interrupt sensitivity of the selected pin as rising edge only IT_EDGE_F Sets the interrupt sensitivity of the selected pin as falling edge only IT_EDGE_FR Sets the interrupt sensitivity of the selected pin as falling edge and rising edge IT_EDGE_R_1 Sets the interrupt sensitivity of the selected pin as rising edge and high level. IT_DEFAULT ¹⁾ Sets the default sensitivity associated with the device.
Required Preconditions	The Port Pin must be configured in Input Interrupt mode.
Functions called	None
Postconditions	None
See also	ITC_DisableInterrupt

1) This option to be used for ST72F62 and ST72F63B devices only.

Notes:

- This function replaces ITC_EXT_ITsensitivity from Library ver1.0
- External Interrupts are masked when an I/O (configured as input interrupt) of the same interrupt vector is forced to Vss.
- If several input pins of a group connected to same interrupt line are selected simultaneously, these will be logically ORed

Caution:

- You must refer to the datasheet of the device while selecting the interrupt Pin and the Interrupt sensitivity at that pin. If you select a sensitivity which is not available for that pin, the sensitivity of the pin will not be changed.

- For devices which have pins with fixed sensitivity the option IT_DEFAULT has to be used. Any other option used also has no effect and the default value is only configured.
- For ST72F264, PortC can be configured as EI0 or EI1 using option bytes. For this the constant EXTIT_VALUE in the device_hr.h file has to be changed as 0 or 1 to configure PortC as EI0 or EI1 respectively.

Table 152. ITC_DisableInterrupt

Function Name	ITC_DisableInterrupt ¹⁾
Function Prototype	Void ITC_DisableInterrupt (ITC_Port Portx, unsigned char Pin)
Behaviour Description	Disables the interrupts at the specified Port & Pin.
Input Parameter 1	IT_Portx x = A, B,C
Input Parameter 2	Pin This value must be between 0 to 7
Required Preconditions	The Port Pin must be configured in Input Interrupt mode.
Functions called	None
Postconditions	The external interrupt will be disabled and alternate function in the pin can be enabled.
See also	ITC_ConfigureInterrupt

1) This function is available only in ST72F62 & ST72F63B

Caution: You must refer to the datasheet of the device while selecting the interrupt Pin. If you select a wrong interrupt pin then the specified interrupt will not be disabled.

Table 153. ITC_Revert_Sensitivity

Function Name	ITC_Revert_Sensitivity
Function Prototype	Void ITC_Revert_Sensitivity (ITC_IT IT)
Behaviour Description	Reverts the sensitivity of the EI0 or EI2 interrupt depending upon the input parameter (See table below).
Input Parameters	IT_EI0 Reverts the sensitivity of External interrupt0 IT_EI2 Reverts the sensitivity of External interrupt2
Output Parameters	None
Required Preconditions	None
Functions called	None
Postconditions	None
See also	None

Note: This function is for ST72F21, ST72325 and ST7232A devices.

Previous Sensitivity	Reverted Sensitivity
Falling edge and low level	Rising edge and high level
Rising edge only	Falling edge only
Falling edge only	Rising edge only
Rising and falling edge	Rising and falling edge

Table 154. ITC_EnableTLI

Function Name	ITC_EnableTLI
Function Prototype	Void ITC_EnableTLI (void)
Behaviour Description	Enables the TLI capability on the dedicated pin.
Input Parameters	None
Output Parameters	None
Required Preconditions	None
Functions called	None
Postconditions	None
See also	None

Notes:

- This function is for ST72F521, ST72F561 and ST72325 devices.
- This is a Non Maskable Interrupt source and can interrupt a Level3 program.

Table 155. ITC_DisableTLI

Function Name	ITC_DisableTLI
Function Prototype	Void ITC_DisableTLI (void)
Behaviour Description	Disables the TLI capability on the dedicated pin.
Input Parameters	None
Output Parameters	None
Required Preconditions	None
Functions called	None
Postconditions	None
See also	None

Notes:

- This function is for ST72F521, ST72F561 and ST72325 devices.
- A parasitic interrupt can be generated when disabling the TLI, depending upon the status of the TLI pin.

Table 156. ITC_TLISensitivity

Function Name	ITC_TLISensitivity
Function Prototype	Void ITC_TLISensitivity (ITC_Sensitivity Edge)
Behaviour Description	Sets the TLI sensitivity to falling edge or rising edge as per the Input parameter selected.
Input Parameters	IT_EDGE_R TLI pin is made rising edge sensitive IT_EDGE_F TLI pin is made falling edge sensitive
Output Parameters	None
Required Preconditions	ITC_DisableTLI must have been called.
Functions called	None
Postconditions	None
See also	None

Note: This function is for ST72F521, ST72F561 and ST72325 devices.

EXAMPLE:

The following C program shows the use of the ITC library functions.

Program description:

This program is written for the ST72F521 device. It sets the Software priority level for EI0 External interrupt & TIMERA peripheral interrupt to Level2. Then it sets the software priority of EI2 to Level1. The sensitivity of PA0 (EI0 interrupt pin in ST72F521) and PF0 (EI2) interrupt is set to falling edge. The TLI interrupt is enabled and the sensitivity of the TLI pin is set to Falling edge. A falling edge is applied on the PF0 pin (configured as input interrupt) to generate an EI2 interrupt. Immediately after this, a falling edge is applied on the PA0 pin. As the priority of the EI0 interrupt is higher than EI2, the EI2 interrupt is interrupted and control goes to EI0. Then TLI interrupt is generated by applying a falling edge on the TLI pin. The LEDs connected to the Port D pins are toggled by the interrupt subroutines.

```

/* Example code for ITC for ST72F521 */
#include "ST7lib_config.h"

//prototype declarations
void TLI_IT_Routine (void);
void EI0_IT_Routine(void);
void EI2_IT_Routine(void);
void main(void);

void main (void)
{
    unsigned char Pin = 0;
    ITC_LEVEL Priority = IT_LEVEL_2; /*Variable Declaration*/

    ITC_Init (); /* Initialise ITC */

```

Function Descriptions

```
EnableInterrupts                                     /*Reset Interrupt mask*/
ITC_SetPriority (((unsigned char)IT_TIMER_A | ((unsigned char)IT_EI0)),
                IT_LEVEL_2);

/* Sets Interrupt Priority FOR EI0 AS LEVEL 2 */
ITC_SetPriority (IT_EI2, IT_LEVEL_1);
/* Sets Interrupt Priority FOR EI2 AS LEVEL 1 */
Priority = ITC_GetPriority (IT_EI0);                /* Gets Priority */
while (!(ITC_Get_CurrentLevel () == IT_LEVEL_3));
/* Checks Current interrupt priority */
ITC_ConfigureInterrupt (IT_PortA, Pin, IT_EDGE_F);
/*Set falling edge sensitivity for EI0*/
ITC_ConfigureInterrupt (IT_PortB, Pin, IT_EDGE_F);
/*Set falling edge sensitivity for EI2*/
ITC_DisableTLI ();                                /*Disables TLI interrupt */
ITC_TLISensitivity (IT_EDGE_R);                   /* Sets Rising edge for TLI */
ITC_EnableTLI ();                                /* Enables TLI interrupt */
}

/*****
Interrupt Subroutine for TLI
*****/
#ifdef _HIWARE_                                    /* Test for HIWARE Compiler */
#pragma TRAP_PROC SAVE_REGS                       /* Additional registers will be saved */
#else
#ifdef _COSMIC_                                    /* Test for Cosmic Compiler */
@interrupt                                       /* Cosmic interrupt handling */
#else
#error "Unsupported Compiler!"                   /* Compiler Defines not found! */
#endif
#endif

void TLI_IT_Routine (void)
{
    unsigned int i;
    PDDDR |= 0x04;
    PDOR |= 0x04;
    PDDR |= 0x04;
    for (i = 0; i < 5000; i++)
    {
        Nop
    }
    PDDR &= 0xFB;
}

/*****
Interrupt Subroutine for EI0
*****/
#ifdef _HIWARE_                                    /* Test for HIWARE Compiler */
#pragma TRAP_PROC SAVE_REGS                       /* Additional registers will be saved */
#else
#ifdef _COSMIC_                                    /* Test for Cosmic Compiler */
@interrupt                                       /* Cosmic interrupt handling */
#else
#error "Unsupported Compiler!"                   /* Compiler Defines not found! */
#endif
#endif
```

```
#endif
#endif

void EI0_IT_Routine (void)
{
    unsigned int i;
    PDDDR |= 0x01;
    PDOR |= 0x01;
    PDDR |= 0x01;
    for (i = 0; i < 5000; i++)
    {
        Nop
    }
    PDDR &= 0xFE;
}

/*****
Interrupt Subroutine for EI2
*****/
#ifdef _HIWARE_
/* Test for HIWARE Compiler */
#pragma TRAP_PROC SAVE_REGS /* Additional registers will be saved */
#else
#ifdef _COSMIC_
/* Test for Cosmic Compiler */
@interrupt /* Cosmic interrupt handling */
#else
#error "Unsupported Compiler!" /* Compiler Defines not found! */
#endif
#endif
#endif

void EI2_IT_Routine (void)
{
    unsigned int i;
    PDDDR |= 0x02;
    PDOR |= 0x02;
    PDDR |= 0x02;
    for (i = 0; i < 5000; i++)
    {
        Nop
    }
    PDDR &= 0xFd;
}
```

9.1.14 MCC

Function Name	MCC_Init
Function Prototype	Void MCC_Init (MCC_Init Init_Value)
Behaviour Description	Initialization of MCC. By default, main clock out (MCO) alternate function, beep mode and oscillator interrupt are disabled. You can change the default configuration, by selecting input parameters given below. You can pass one or more parameters by 'OR'ing them.
Input Parameters	MCC_DEFAULT Load MCC registers with reset value (00h). MCO_ENABLE Enables main clock out alternate function. MCC_IT_ENABLE Enables oscillator interrupt.
Output Parameters	None
Required Preconditions	None
Functions called	None
Postconditions	None
See also	None

Note: If you want to enable interrupts, parameter MCC_IT_ENABLE has to be passed in the MCC_Init function. You must then use the “EnableInterrupts” macro to reset the Interrupt mask.

Caution: The MCO function is stopped during Active-Halt mode.

Table 157. MCC_SlowMode

Function Name	MCC_SlowMode
Function Prototype	Void MCC_SlowMode (MCC_Mode Slow_Mode, MCC_Param Config_Value)
Behaviour Description	Selects f_{CPU} main clock frequency depending on the input.
Input Parameter 1	<p>MCC_SLOW_ENABLE Enables slow mode.</p> <p>MCC_SLOW_DISABLE Disables slow mode.</p>
Input Parameter 2	<p>MCC_CLK_0 Selects clock as f_{OSC2}. This parameter is passed when slow mode is disabled.</p> <p>MCC_CLK_2¹⁾ Selects clock as $f_{OSC2} / 2$.</p> <p>MCC_CLK_4¹⁾ Selects clock as $f_{OSC2} / 4$.</p> <p>MCC_CLK_8¹⁾ Selects clock as $f_{OSC2} / 8$.</p> <p>MCC_CLK_16¹⁾ Selects clock as $f_{OSC2} / 16$.</p> <p>MCC_CLK_32²⁾ Selects clock as $f_{OSC} / 32$.</p>
Output Parameters	None
Required Preconditions	MCC_Init must have been called.
Functions called	None
Postconditions	None
See also	None

1) This parameter is applicable for ST72F521, ST72325 and ST7232A devices, when slow mode is enabled.

2) This parameter is applicable for ST7FLite0 device, when slow mode is enabled.

Table 158. MCC_RTC_Timer

Function Name	MCC_RTC_Timer
Function Prototype	Void MCC_RTC_Timer (MCC_RTC_Param Timer_Value)
Behaviour Description	Selects the programmable divider time base. Oscillator interrupts are generated, as per the timebase selection. You have to select the input values from the table shown below.
Input Parameters	MCC_RTC_X x= 0,1,2,3. You have to select values, to decide the time base for oscillator interrupt.
Output Parameters	None
Required Preconditions	MCC_Init must have been called.
Functions called	None
Postconditions	None
See also	None

Notes:

- The MCC/ RTC interrupt wakes up the MCU from ACTIVE-HALT mode, not from HALT mode.
- A modification of time base is taken into account at the end of the current period (previously set), to avoid an unwanted time shift.

MCC_RTC_X	Timebase for f_{OSC2} = 1MHz	Timebase for f_{OSC2} = 2MHz	Timebase for f_{OSC2} = 4MHz	Timebase for f_{OSC2} = 8MHz
MCC_RTC_0	16ms	8ms	4ms	2ms
MCC_RTC_1	32ms	16ms	8ms	4ms
MCC_RTC_2	80ms	40ms	20ms	10ms
MCC_RTC_3	200ms	100ms	50ms	25ms

Notes:

The timebase for other f_{OSC2} can be reached by calculation, as shown below.

For MCC_RTC_0, Timebase = 32000/(2*f_{OSC2}).

For MCC_RTC_1, Timebase = 64000/(2*f_{OSC2}).

For MCC_RTC_2, Timebase = 160000/(2*f_{OSC2}).

For MCC_RTC_3, Timebase = 400000/(2*f_{OSC2}).

For example, if f_{OSC2} = 5MHz, for the MCC_RTC_X input values, the timebase values are as follows.

For MCC_RTC_0, Timebase = 3.2 ms,

For MCC_RTC_1, Timebase = 6.4 ms,

For MCC_RTC_2, Timebase = 16 ms,

For MCC_RTC_3, Timebase = 40 ms.

Table 159. MCC_ActiveHalt

Function Name	MCC_ActiveHalt
Function Prototype	Void MCC_ActiveHalt (void)
Behaviour Description	Enables oscillator interrupt and enters into ACTIVE-HALT power saving mode.
Input Parameters	None
Output Parameters	None
Required Preconditions	None
Functions called	None
Postconditions	None
See also	MCC_Init

Table 160. MCC_Beep

Function Name	MCC_Beep
Function Prototype	Void MCC_Beep (MCC_Beep_Param Beep_Value)
Behaviour Description	Selects the Beeper output signal by selecting one of the below parameters.
Input Parameters	<p>MCC_BEEP_1 Selects beep signal approximately as $f_{OSC2} / 4000$ (~50% duty cycle).</p> <p>MCC_BEEP_2 Selects beep signal approximately as $f_{OSC2} / 8000$ (~50% duty cycle).</p> <p>MCC_BEEP_3 Selects beep signal approximately as $f_{OSC2} / 16000$ (~50% duty cycle).</p>
Output Parameters	None
Required Preconditions	MCC_Init must have been called.
Functions called	None
Postconditions	None
See also	None

Note: The beep signal is available in ACTIVE-HALT mode, but has to be disabled to reduce the consumption.

Table 161. MCC_Clear_IT

Function Name	MCC_Clear_IT
Function Prototype	Void MCC_Clear_IT (void)
Behaviour Description	Clears oscillator interrupt flag.
Input Parameters	None
Output Parameters	None
Required Preconditions	None
Functions called	None
Postconditions	None
See also	MCC_RTC_Timer

Table 162. MCC_IT_Disable

Function Name	MCC_IT_Disable
Function Prototype	Void MCC_IT_Disable (void)
Behaviour Description	Disables oscillator interrupt.
Input Parameters	None
Output Parameters	None
Required Preconditions	None
Functions called	None
Postconditions	None
See also	MCC_Init

EXAMPLE:

The following C program shows the use of the MCC functions.

Program Description:

This program configures f_{CPU} main clock frequency as 2 MHz, oscillator interrupt timebase as 4ms and generates 1 KHz beep signal.

```

/*=====*/
/* Program Start */

#include "ST7lib_config.h"
/* File for user to select device as ST72F521, Fosc2 as 8MHz */

//protoypte declaration
void MCC_IT_Routine (void);
void main(void);

void main (void)
{
    /* MCC initialised. Main clock out and oscillator interrupt enabled */
    MCC_Init (((unsigned char)MCO_ENABLE | (unsigned char)MCC_IT_ENABLE));
    EnableInterrupts
    MCC_SlowMode (MCC_SLOW_ENABLE, MCC_CLK_4);
    /* Fcpu selected as 2 MHz */
    MCC_RTC_Timer (MCC_RTC_1);
    WaitforInterrupt
    /* Time base selected as 4ms */
    /* Waiting for interrupt */
}

/*****
Interrupt Service Routine:
An example of 1kHz beep signal generation in BEEP pin, is given, which will
be executed when RTC interrupt is generated.
*****/
#ifdef _HIWARE_
/* Test for HIWARE Compiler */
#pragma TRAP_PROC SAVE_REGS
/* Additional registers will be saved */
#else
/* Test for Cosmic Compiler */
/* Cosmic interrupt handling */
#endif
#error "Unsupported Compiler!"
/* Compiler Defines not found! */
#endif
void MCC_IT_Routine (void)
{
    MCC_Clear_IT ();
    /* Clears the interrupt */
    MCC_Beep (MCC_BEEP_2);
    /* Generates 1 KHz beep signal */
}

```

9.1.15 EEPROM

Following are the functions related to EEPROM.

Function Name	EEPROM_Init
Function Prototype	Void EEPROM_Init (void)
Behaviour Description	Initialization of EEPROM. Loads the EEPROM register with reset value (00h).
Input Parameters	None
Output Parameters	None
Required Preconditions	Selection of the right EEPROM device in the file "ST7lib_config.h".
Functions called	None
Postconditions	None
See also	None

Notes:

- The EEPROM can enter WAIT mode, on execution of the WFI instruction of the microcontroller. If programming is in progress, then EEPROM will finish the current cycle and then enter WAIT mode.
- The EEPROM immediately enters HALT mode if the microcontroller executes the HALT instruction. Therefore, EEPROM will stop the function in progress and the data may be corrupted.

Table 163. EEPROM_Read

Function Name	EEPROM_Read
Function Prototype	For Metrowerks, void EEPROM_Read (unsigned char * PtrToUsrBuffer, unsigned char NbOfBytes, unsigned char * far PtrToE2Buffer) For Cosmic, void EEPROM_Read (unsigned char * PtrToUsrBuffer, unsigned char NbOfBytes, @near unsigned char * PtrToE2Buffer)
Behaviour Description	Reads data from EEPROM memory and stores it in the user buffer.
Input Parameter 1	*PtrToUsrBuffer User address, where data has to be stored.
Input Parameter 2	NbOfBytes Number of bytes you want to read from EEPROM memory
Input Parameter 3	*PtrToE2Buffer EEPROM memory address, from where data has to be read.
Output Parameters	None
Required Preconditions	None
Functions called	None
Postconditions	None
See also	None

Notes:

- The value of *PtrToE2Buffer can be from 0x1000h to 0x107Fh for LITE0/1/2/3, ST7SUPERLITE and ST7DALI device.
- You have to type-cast parameter PtrToE2Buffer to unsigned char * in the function EEPROM_Read as shown in example (page 218).
- Because of the limitation of ST7FLite0/1/2/3, ST7SUPERLITE and ST7DALI ZRAM and RAM size (which is 64 bytes each), you must take care while declaring the size of user buffer.

Table 164. EEPROM_Write

Function Name	EEPROM_Write
Function Prototype	For Metrowerks, void EEPROM_Write (unsigned char * PtrToUsrBuffer, unsigned char NbOfBytes, unsigned char * far PtrToE2Buffer) For Cosmic, void EEPROM_Write (unsigned char * PtrToUsrBuffer, unsigned char NbOfBytes, @near unsigned char * PtrToE2Buffer)
Behaviour Description	Writes up to 32 bytes of data from user buffer to EEPROM memory.
Input Parameter 1	*PtrToUsrBuffer User address where data exists.
Input Parameter 2	NbOfBytes Number of bytes you want to write in EEPROM memory. You can write up to 32 bytes.
Input Parameter 3	*PtrToE2Buffer EEPROM memory address, where data will be written.
Output Parameters	None
Required Preconditions	None
Functions called	None
Postconditions	You must call EEPROM_Programming after this function.
See also	EEPROM_Programming

Notes:

- The value of *PtrToE2Buffer can be from 0x1000h to 0x107Fh for ST7FLite0/1/2/3, ST7SUPERLITE and ST7DALI device.
- You have to type-cast parameter PtrToE2Buffer to unsigned char * in the function EEPROM_Write as shown in example (page 218).
- To avoid incorrect programming, take care that all the bytes written between the two programming sequences have the same high address: only the four Least Significant Bits of the address can change.
- Because of the ST7FLite0/1/2/3, ST7SUPERLITE and ST7DALI ZRAM and RAM size limitation (which is 64 bytes each), you must take care while declaring the size of user buffer.

Table 165. EEPROM_Programming

Function Name	EEPROM_Programming
Function Prototype	Prog_Status EEPROM_Programming (void)
Behaviour Description	Starts writing data bytes from EEPROM latches to EEPROM cells and returns the programming status.
Input Parameters	None
Output Parameters	EEPROM_PROG_COMPLETE If all data bytes are written from latch to EEPROM cells. EEPROM_PROG_PROGRESS If programming cycle is in progress.
Required Preconditions	EEPROM_Write must have been called.
Functions called	None
Postconditions	This function can be looped, until the programming cycle is complete.
See also	EEPROM_Write

Notes:

- Care should be taken during programming cycle. Writing to the same memory location will over-program the memory. If a programming cycle is interrupted (by software or a reset action), the integrity of the data in memory is not guaranteed.
- Reading the EEPROM memory is not possible when the data writing is in progress.

Example

The following C program shows the uses of the EEPROM functions for the Lite0 device.

Program Description:

This program writes 5 data bytes in EEPROM memory from one user buffer, Temp1. Then data bytes are read from the same EEPROM memory and stored in another buffer, Temp2. The written data and data read from the two buffers are then compared.

```
/*=====*/
/* Program Start */

#include "ST7lib_Config.h" /* File for user to select device as lite0 */
#ifdef _HIWARE_
unsigned char ptr_address @ 0x1000;
#endif
#ifdef _COSMIC_
@near unsigned char ptr_address @ 0x1000;
#endif

void main(void);
void main (void)
{
    int i;
    unsigned char NoofBytes = 5;
    unsigned char Temp1[5] = {0x55, 0xAA, 0x7F, 0x18, 0x4C};
    unsigned char Temp2[5] = {0x00, 0x00, 0x00, 0x00, 0x00};
    /*@far unsigned char * ptr_write;
    @far unsigned char * ptr_read;
    ptr_read = &ptr_address;
    ptr_write = &ptr_address;*/

    EEPROM_Init (); /* All EEPROM registers initialised to reset value */
    EEPROM_Write (Temp1, NoofBytes, &ptr_address);
    /* Data written from buffer Temp1 to EEPROM memory address 1000h */
    /* EEPROM_Write (Temp1, 5, (unsigned char * far) 0x1000); */ /* Write function
    is called in this way for hiware compiler, when small memory model is used */
    while (EEPROM_Programming () != EEPROM_PROG_COMPLETE);
    /* Waiting till all data bytes programmed from latch to EEPROM cells */

    EEPROM_Read (Temp2, NoofBytes, &ptr_address);
    /* Reads data from EEPROM address 1000h and stores it in buffer Temp2 */
    /* EEPROM_Read (Temp2, 5, (unsigned char * far) 0x1000); */ /* Read function
    is called in this way for hiware compiler, when small memory model is used */
    for (i = 0; i < 5; i++)
    {
        /* Comparison of written data and data read */
        if ((* (Temp1+i)) != (* (Temp2+i)))
        {
            /* Mismatch between written data and data read */
            while (1);
        }
    }
}
/*Program Stop */
/*=====*/
```

9.1.16 I/O

The following are the functions related to Input/Output ports.

Function Name	IO_Init
Function Prototype	Void IO_Init (void)
Behaviour Description	Initialization of IO. Loads IO registers with reset value (00h).
Input Parameters	None
Output Parameters	None
Required Preconditions	Selection of the right device in the file "ST7lib_config.h".
Functions called	None
Postconditions	None
See also	None

Note: The bits associated with unavailable pins must always keep their reset value.

Table 166. IO_Input

Function Name	IO_Input
Function Prototype	Void IO_Input (IO_Input_Mode Input_Val, IO_Port Port_Val1, IO_Pin Pin_Val1)
Behaviour Description	Configures the I/O ports in input mode. You can also select external interrupt function, by selecting the corresponding input parameters. Refer to the datasheet to select the input mode and input port name.
Input Parameter 1	Select the input mode, by selecting one of the below parameters. IO_FLOATING Selects floating input mode. IO_FLOATING_IT Selects floating input mode, with external interrupt. IO_PULL_UP Selects pull-up input mode. IO_PULL_UP_IT Selects pull-up input mode, with external interrupt.
Input Parameter 2	Selects the port name. IO_PORT_X X= A,B,... The port name has to selected with reference to the datasheet.
Input Parameter 3	Selects port pin number. You can select more than one pin number, by 'OR'ing them. IO_PIN_Y Y= 0 to 7.
Output Parameters	None
Required Preconditions	None
Functions called	None
Postconditions	None
See also	None

Notes:

- You can use this function to configure pins as floating input, when the pins are used as ADC input.
- If you want to select external interrupt, you should use the “EnableInterrupts” macro after this function.

Caution:

- Alternate function must not be activated, while the pin is configured as input with interrupt, in order to avoid generating spurious interrupts.
- Input pull-up configuration can cause an unexpected value at the input of the alternate peripheral.

Table 167. IO_Output

Function Name	IO_Output
Function Prototype	Void IO_Output (IO_Output_Mode Output_Val, IO_Port Port_Val2, IO_Pin Pin_Val2)
Behaviour Description	Configures the I/O ports in output mode. Refer to the datasheet to select the output mode and output port name.
Input Parameter 1	Selects the output mode, by selecting one of the below parameters. IO_OPEN_DRAIN Selects open drain output mode IO_PUSH_PULL Selects push-pull output mode
Input Parameter 2	Selects the port name. IO_PORT_R R = A,B,... The port name has to be selected with reference to the datasheet
Input Parameter 3	Selects port pin number. Here you can select more than one pin number, by 'OR'ing them. IO_PIN_S S = 0 to 7.
Output Parameters	None
Required Preconditions	None
Functions called	None
Postconditions	You must call IO_Write after this function, if you want to write data in the port register.
See also	None

Table 168. IO_Read

Function Name	IO_Read
Function Prototype	Unsigned char IO_Read (IO_Port Read_Val)
Behaviour Description	Reads the port and returns the value.
Input Parameters	Selects the port name. IO_PORT_U U = A,B,... The port name has to selected with reference to the datasheet.
Output Parameters	Unsigned char Port_Data Returns the data in the port register.
Required Preconditions	None
Functions called	None
Postconditions	None
See also	None

Note: When the IO port is in input configuration and associated alternate function is enabled as an output, reading the port (DR) register will read the alternate function output status.

Table 169. IO_ByteWrite

Function Name	IO_ByteWrite
Function Prototype	Void IO_ByteWrite (IO_Port Port_Val4,unsigned char IO_ByteData)
Behaviour Description	Writes data byte into port register.
Input Parameter 1	Selects the port name. IO_PORT_X X= A,B,... The port name has to selected with reference to the datasheet.
Input Parameter 2	IO_ByteData Data byte to be written into port register
Output Parameters	None
Required Preconditions	If you want to write data in output mode, IO_Output must have been called.
Functions called	None
Postconditions	None
See also	None

Caution: When you write data in a port register in this function, the previous data in the port is modified.

Table 170. IO_Write

Function Name	IO_Write
Function Prototype	Void IO_Write (IO_Port Port_Val3,IO_Pin Pin_Val3, IO_Write_Data Data_Val)
Behaviour Description	Writes the data into the port pins.
Input Parameter 1	Selects the port name. IO_PORT_V V= A,B,... The port name as per datasheet.
Input Parameter 2	Selects port pin number. Here you can select more than one pin number by 'OR'ing them. IO_PIN_W W= 0 to 7.
Input Parameter 3	Selects the data to be written in the port pin. IO_DATA_HIGH Writes logic high in port pin IO_DATA_LOW Writes logic low in port pin IO_DATA_TOGGLE Toggles port pin
Output Parameters	None
Required Preconditions	To write data in output mode, IO_Output must have been called.
Functions called	None
Postconditions	None
See also	None

Notes:

- When the I/O port is in output configuration and associated alternate function is enabled as an input, the alternate function reads the pin status given by the port (DR) register content.
- This function reads DR register, performs the bit operations and writes back DR. This could give different results in some situations, to avoid this use IO_ByteWrite with shadow register variables.

EXAMPLE:

The following C program shows the use of the I/O functions.

Program Description:

This program, written for the ST72F521 device, configures all Port D pins in push-pull output mode. The D5 and D7 port pins are put into logic high state. The port register is read and the data is compared with the written data. If there is any mismatch between the data read and data written, the control goes into a 'while' loop.

It then configures Port C (C3 & C4) in floating input mode. The C3 and C4 port pins are put into logic high state by the external input. Then, port C is read. The read value is compared with expected value, i.e., 0x18. If there is any mismatch between the data read and expected data, the control goes into a 'while' loop.

```
/*=====*/
/* Program Start */

#include "ST7lib_config.h" /* File for user to select device as ST72F521 */

void main(void);
void main(void)
{
    unsigned char Temp = 0x00;

    IO_Init (); /* All IO registers initialised to reset value (00h) */

    IO_Output (IO_PUSH_PULL, IO_PORT_A, ((unsigned char) IO_PIN_1 |
        ((unsigned char) IO_PIN_2 | ((unsigned char) IO_PIN_3 | ((unsigned char) IO_PIN_4
            | ((unsigned char) IO_PIN_5 | ((unsigned char) IO_PIN_6 |
                ((unsigned char) IO_PIN_7))))));

    IO_Output (IO_OPEN_DRAIN, IO_PORT_B, ((unsigned char) IO_PIN_0 |
        ((unsigned char) IO_PIN_2 | ((unsigned char) IO_PIN_3 | ((unsigned char)
            IO_PIN_4 | ((unsigned char) IO_PIN_5 | ((unsigned char) IO_PIN_6 |
                ((unsigned char) IO_PIN_7))))));

    IO_Output (IO_PUSH_PULL, IO_PORT_C, ((unsigned char) IO_PIN_0 |
        ((unsigned char) IO_PIN_1 | ((unsigned char) IO_PIN_3 | ((unsigned char) IO_PIN_4
            | ((unsigned char) IO_PIN_5 | ((unsigned char) IO_PIN_6 |
                ((unsigned char) IO_PIN_7))))));

    IO_Output (IO_OPEN_DRAIN, IO_PORT_D, ((unsigned char) IO_PIN_0 |
        ((unsigned char) IO_PIN_1 | ((unsigned char) IO_PIN_2 | ((unsigned char) IO_PIN_4
            | ((unsigned char) IO_PIN_5 | ((unsigned char) IO_PIN_6 |
                ((unsigned char) IO_PIN_7))))));

    IO_Output (IO_PUSH_PULL, IO_PORT_E, ((unsigned char) IO_PIN_0 |
        ((unsigned char) IO_PIN_1 | ((unsigned char) IO_PIN_2 | ((unsigned char)
            IO_PIN_3 | ((unsigned char) IO_PIN_5 | ((unsigned char) IO_PIN_6 |
                ((unsigned char) IO_PIN_7))))));

    IO_Output (IO_OPEN_DRAIN, IO_PORT_F, ((unsigned char) IO_PIN_0 |
        ((unsigned char) IO_PIN_1 | ((unsigned char) IO_PIN_2 | ((unsigned char)
```

```

        IO_PIN_3 | ((unsigned char) IO_PIN_4 | ((unsigned char) IO_PIN_6 |
            ((unsigned char) IO_PIN_7))))));

IO_Write (IO_PORT_A, ((unsigned char) IO_PIN_0 | ((unsigned char) IO_PIN_1 |
    ((unsigned char) IO_PIN_2 | ((unsigned char) IO_PIN_3 | ((unsigned char)
        IO_PIN_4 | ((unsigned char) IO_PIN_5)))))), IO_DATA_HIGH);

IO_Write (IO_PORT_B, ((unsigned char) IO_PIN_0 | ((unsigned char) IO_PIN_1 |
    ((unsigned char) IO_PIN_2 | ((unsigned char) IO_PIN_3 | ((unsigned char)
        IO_PIN_6 | ((unsigned char) IO_PIN_7)))))), IO_DATA_HIGH);

IO_Write (IO_PORT_C, ((unsigned char) IO_PIN_2 | ((unsigned char) IO_PIN_3 |
    ((unsigned char) IO_PIN_4 | ((unsigned char) IO_PIN_5 | ((unsigned char)
        IO_PIN_6 | ((unsigned char) IO_PIN_7)))))), IO_DATA_HIGH);

IO_Write (IO_PORT_D, ((unsigned char) IO_PIN_0 | ((unsigned char) IO_PIN_1 |
    ((unsigned char) IO_PIN_2 | ((unsigned char) IO_PIN_5 | ((unsigned char)
        IO_PIN_6 | ((unsigned char) IO_PIN_7)))))), IO_DATA_HIGH);

IO_Write (IO_PORT_E, ((unsigned char) IO_PIN_0 | ((unsigned char) IO_PIN_1 |
    ((unsigned char) IO_PIN_4 | ((unsigned char) IO_PIN_5 | ((unsigned char)
        IO_PIN_6 | ((unsigned char) IO_PIN_7)))))), IO_DATA_HIGH);

IO_Write (IO_PORT_F, ((unsigned char) IO_PIN_0 | ((unsigned char) IO_PIN_1 |
    ((unsigned char) IO_PIN_2 | ((unsigned char) IO_PIN_3 | ((unsigned char)
        IO_PIN_6 | ((unsigned char) IO_PIN_7)))))), IO_DATA_HIGH);

IO_Write (IO_PORT_B, ((unsigned char) IO_PIN_0 | ((unsigned char) IO_PIN_1 |
    ((unsigned char) IO_PIN_2 | ((unsigned char) IO_PIN_3 | ((unsigned char)
        IO_PIN_6 | ((unsigned char) IO_PIN_7)))))), IO_DATA_LOW);

Temp = IO_Read (IO_PORT_B); /* Reads the port D contents */
while (Temp != 0x00);
Temp = 0x00;
Temp = IO_Read (IO_PORT_A); /* Reads the port D contents */
while (Temp != 0x3f);
Temp = 0x00;
Temp = IO_Read (IO_PORT_C); /* Reads the port D contents */
while (Temp != 0xf8);
Temp = 0x00;
Temp = IO_Read (IO_PORT_D); /* Reads the port D contents */
while (Temp != 0xe7);
Temp = 0x00;
Temp = IO_Read (IO_PORT_E); /* Reads the port D contents */
while (Temp != 0xe3);
Temp = 0x00;
Temp = IO_Read (IO_PORT_F); /* Reads the port D contents */
while (Temp != 0xcf);

IO_Input (IO_PULL_UP, IO_PORT_A, ((unsigned char) IO_PIN_2 | ((unsigned char)
    IO_PIN_3 | ((unsigned char) IO_PIN_4 | ((unsigned char) IO_PIN_5 |
        ((unsigned char) IO_PIN_6 | ((unsigned char) IO_PIN_7))))));

IO_Input (IO_FLOATING, IO_PORT_C, ((unsigned char) IO_PIN_2 | ((unsigned char)
    IO_PIN_3 | ((unsigned char) IO_PIN_4 | ((unsigned char) IO_PIN_5 |

```

Function Descriptions

```
        ((unsigned char) IO_PIN_6 | ((unsigned char) IO_PIN_7))))));

IO_Input (IO_FLOATING, IO_PORT_D, ((unsigned char) IO_PIN_2 | ((unsigned char)
    IO_PIN_3 | ((unsigned char) IO_PIN_4 | ((unsigned char) IO_PIN_5 |
        ((unsigned char) IO_PIN_6 | ((unsigned char) IO_PIN_7))))));

IO_Input (IO_PULL_UP, IO_PORT_E, ((unsigned char) IO_PIN_2 | ((unsigned char)
    IO_PIN_3 | ((unsigned char) IO_PIN_4 | ((unsigned char) IO_PIN_5 |
        ((unsigned char) IO_PIN_6 | ((unsigned char) IO_PIN_7))))));

IO_Input (IO_FLOATING, IO_PORT_F, ((unsigned char) IO_PIN_2 | ((unsigned char)
    IO_PIN_3 | ((unsigned char) IO_PIN_4 | ((unsigned char) IO_PIN_5 |
        ((unsigned char) IO_PIN_6 | ((unsigned char) IO_PIN_7))))));

IO_Input (IO_PULL_UP_IT, IO_PORT_B, ((unsigned char) IO_PIN_2 | ((unsigned char)
    IO_PIN_3 | ((unsigned char) IO_PIN_4 | ((unsigned char) IO_PIN_5 |
        ((unsigned char) IO_PIN_6 | ((unsigned char) IO_PIN_7))))));

IO_Output (IO_PUSH_PULL, IO_PORT_B, ((unsigned char) IO_PIN_1 |
    ((unsigned char) IO_PIN_2 | ((unsigned char) IO_PIN_3 | ((unsigned char)
        IO_PIN_4 | ((unsigned char) IO_PIN_5 | ((unsigned char) IO_PIN_6 |
            ((unsigned char) IO_PIN_7))))));

IO_Output (IO_OPEN_DRAIN, IO_PORT_A, ((unsigned char) IO_PIN_0 |
    ((unsigned char) IO_PIN_2 | ((unsigned char) IO_PIN_3 | ((unsigned char)
        IO_PIN_4 | ((unsigned char) IO_PIN_5 | ((unsigned char) IO_PIN_6 |
            ((unsigned char) IO_PIN_7))))));

IO_Output (IO_PUSH_PULL, IO_PORT_D, ((unsigned char) IO_PIN_0 | ((unsigned char)
    IO_PIN_1 | ((unsigned char) IO_PIN_3 | ((unsigned char) IO_PIN_4 | ((unsigned char)
        IO_PIN_5 | ((unsigned char) IO_PIN_6 | ((unsigned char) IO_PIN_7))))));

IO_Output (IO_OPEN_DRAIN, IO_PORT_C, ((unsigned char) IO_PIN_0 |
    ((unsigned char) IO_PIN_1 | ((unsigned char) IO_PIN_2 | ((unsigned char)
        IO_PIN_4 | ((unsigned char) IO_PIN_5 | ((unsigned char) IO_PIN_6 |
            ((unsigned char) IO_PIN_7))))));

IO_Output (IO_PUSH_PULL, IO_PORT_F, ((unsigned char) IO_PIN_0 | ((unsigned char)
    IO_PIN_1 | ((unsigned char) IO_PIN_2 | ((unsigned char) IO_PIN_3 | ((unsigned char)
        IO_PIN_5 | ((unsigned char) IO_PIN_6 | ((unsigned char) IO_PIN_7))))));

IO_Output (IO_OPEN_DRAIN, IO_PORT_E, ((unsigned char) IO_PIN_0 |
    ((unsigned char) IO_PIN_1 | ((unsigned char) IO_PIN_2 |
        ((unsigned char) IO_PIN_3 | ((unsigned char) IO_PIN_4 | ((unsigned char) IO_PIN_6 |
            ((unsigned char) IO_PIN_7))))));

IO_ByteWrite (IO_PORT_A, (unsigned char) 0x77) ;
IO_ByteWrite (IO_PORT_B, (unsigned char) 0x88) ;
IO_ByteWrite (IO_PORT_C, (unsigned char) 0xAA) ;
IO_ByteWrite (IO_PORT_D, (unsigned char) 0x55) ;
IO_ByteWrite (IO_PORT_E, (unsigned char) 0xFF) ;
IO_ByteWrite (IO_PORT_F, (unsigned char) 0x1C) ;

}

```

9.2 APPLICATION SPECIFIC PERIPHERALS

9.2.1 CAN LIBRARY FUNCTION LIST

This part of the user manual contains the detailed description of all the functions for the CAN Library.

Note: These functions are only available for the ST72F561 CAN Peripheral.

9.2.1.1 Initialization-Services

Table 171. CanInitPowerOn

Function Name	CanInitPowerOn
Function Prototype	void CanInitPowerOn (void)
Input Parameters	None
Output Parameters	None
Behaviour Description	This service initializes the CAN driver internal variables. Indication and Confirmation flags are reset. Tx/Rx buffers are cleared.

Table 172. CanInit

Function Name	CanInit
Function Prototype	void CanInit (CanInitHandle <initObject>)
Input Parameters	initObject - Selected Initialization Mode. For example- If the value passed is 0, the Can-Controller will be initialized with the values of init table (0).
Output Parameters	None
Behaviour Description	This service initializes the CAN Controller registers with the values stored in the init table corresponding to the <initObject>. Pending transmit requests within the CAN controller are deleted. Receive FIFO is released.
Required Preconditions	The function shall be called after CanInitPowerOn() and before any other services of the driver.

9.2.1.2 Transmit-Services

Table 173. CanTransmit

Function Name	CanTransmit
Function Prototype	canuint8 CanTransmit (CanTransmitHandle <transmitObject>)
Input Parameters	transmitObject - Selected transmit Handle
Output Parameters	KCANTXOK - If the transmit request is accepted by the CAN driver. KCANTXFAILED- If the transmit request is not accepted by the CAN driver.
Behaviour Description	This service initiates the transmission within the CAN controller for the CAN message referenced by <transmitObject>. If any transmit mailbox is empty, the transmit process is initiated and KCANTXOK is returned. The message information (message ID, DLC, data) is taken from the transmit message table referenced by transmit handle <transmitObject> and it is copied into the transmit registers. If message is transmitted successfully, the confirmation flag is set for this message inside the transmit interrupt routine (CanTx_ISR). Transmit process is initiated and If none of the mailbox is empty or the <transmitObject> is out of range then transmit process is not initiated and KCANTXFAILED is returned.
Required Preconditions	This service shall not be called when the CAN driver is in stop or sleep mode.

Table 174. CanCancelTransmit

Function Name	CanCancelTransmit
Function Prototype	void CanCancelTransmit (CanTransmitHandle <txHandle>)
Input Parameters	txHandle - Selected transmit Handle
Output Parameters	None
Behaviour Description	This service cancels a transmit request by making an Abort Request. The message is aborted if the mailbox is in pending or scheduled state. The confirmation flag is not set for this message.

Table 175. CanMsgTransmit

Function Name	CanMsgTransmit
Function Prototype	canuint8 CanMsgTransmit (tCanMsgObject* <txData>)
Input Parameters	txData - Pointer to structure which contains CAN-Id, CAN-DLC, CAN-Frame Data.
Output Parameters	KCANTXOK - Request is accepted by CAN driver. KCANTXFAILED - Request is not accepted by CAN driver.
Behaviour Description	This service initiates the transmission for the message referenced by <txData>. The service returns KCANTXOK if the CAN driver accepts the request. The service returns KCANTXFAILED otherwise.
Required Preconditions	This service shall not be called when the CAN driver is in stop or sleep mode.

Table 176. CanCancelMsgTransmit

Function Name	CanCancelMsgTransmit
Function Prototype	void CanCancelMsgTransmit (void)
Input Parameters	None
Output Parameters	None
Behaviour Description	This service cancels a transmit request from the service CanMsgTransmit().

9.2.1.3 Sleep/Wakeup Services

Table 177. CanSleep

Function Name	CanSleep
Function Prototype	canuint8 CanSleep (void)
Input Parameters	None
Output Parameters	KCANFAILED - If Sleep mode not entered KCANOK - If Sleep mode entered
Behaviour Description	This service puts the controller into the sleep mode. This reduces the power consumption of the CAN controller. The service enables the autowakeup mode of the CAN controller so that CAN controller automatically performs the wake-up sequence on detection of CAN bus activity. You can wakeup the CAN controller using the CanWakeUp() service. If the sleep mode is entered, the service returns KCANOK. Sleep mode is not entered if any message transmission is ongoing during call of this service. Then the service returns KCANFAILED.
Required Preconditions	This service shall not be called while Tx/Rx is in progress.

Table 178. CanWakeup

Function Name	CanWakeup
Function Prototype	canuint8 CanWakeup (void)
Input Parameters	None
Output Parameters	KCANOK - Sleep Mode left
Behaviour Description	This service puts the CAN controller into the normal operating mode.

9.2.1.4 Status Information Service

Table 179. CanGetStatus

Function Name	CanGetStatus
Function Prototype	canuint8 CanGetStatus (void)
Input Parameters	None
Output Parameters	KCANHWISSLEEP - CAN controller is in sleep mode KCANHWISBUSOFF - CAN controller entered BusOff state KCANHWISPASSIVE - Error Passive limit has been reached KCANHWISWARNING - Error Warning limit has been reached
Behaviour Description	This service returns the current status of the CAN controller.

9.2.1.5 Transmit/Receive Task Services

Table 180. CanTx_ISR

Function Name	CanTx_ISR
Function Prototype	void CanTx_ISR (void)
Input Parameters	None
Output Parameters	None
Behaviour Description	This service handles the wakeup, error and transmit mailbox empty interrupts. Wakeup and Error interrupt flags are cleared for wakeup and error interrupts. In the event of transmit interrupt, the confirmation flag is set for the message transmitted. (Note- confirmation is raised for the messages requested by service CanTransmit()).

Table 181. CanRx_ISR

Function Name	CanRx_ISR
Function Prototype	void CanRx_ISR (void)
Input Parameters	None
Output Parameters	None
Behaviour Description	This service handles the receive FIFO interrupt. Received message(CAN-ID, CAN-DATA) is copied into the Rx buffer corresponding to the message received. Rx buffer, into which data is copied, is identified by the filter match index. The Indication flag is set for the message received.

9.2.1.6 Interrupt Services

Table 182. CanGlobalInterruptDisable

Function Name	CanGlobalInterruptDisable
Function Prototype	void CanGlobalInterruptDisable (void)
Input Parameters	None
Output Parameters	None
Behaviour Description	This service disables the interrupt by setting the global interrupt flag of the microcontroller.

Table 183. CanGlobalInterruptRestore

Function Name	CanGlobalInterruptRestore
Function Prototype	void CanGlobalInterruptRestore (void)
Input Parameters	None
Output Parameters	None
Behaviour Description	This service enables the interrupt by clearing the global interrupt flag of the microcontroller.

Table 184. CanCanInterruptDisable

Function Name	CanCanInterruptDisable
Function Prototype	void CanCanInterruptDisable (void)
Input Parameters	None
Output Parameters	None
Behaviour Description	This service disables all CAN interrupts by changing the CAN interrupt control flags.

Table 185. CanCanInterruptRestore

Function Name	CanCanInterruptRestore
Function Prototype	void CanCanInterruptRestore (void)
Input Parameters	None
Output Parameters	None
Behaviour Description	This service enables all CAN interrupts by changing the CAN interrupt control flags.

10 APPENDIX A

10.1 SUPPORTED DEVICES AND THEIR PERIPHERALS

Device Family	ST72F62	ST72F63B	ST72F65	ST72F521	ST72F325	ST72F32A	ST7FLITE0	ST7FLITE1	ST7FLITE2	ST7FLITE3	ST72F264	ST72F561	ST7SUPERLITE
Supported P/Ns	ST72F621 ST72F622 ST72F623 ST72F611	ST72F63BK1 ST72F63BK2 ST72F63BK3	ST72F65	ST72F521 ST72F521B ST72F321 ST72F321B ST72F324 ST72F324B/L/J/L	ST72F325(AR/C/J/K)6/7/9 ST72F325(C/J/K)4	ST72F32AK2	ST7FLITE02 ST7FLITE05 ST7FLITE09	ST7FLITE10 ST7FLITE15 ST7FLITE19 ST7FLITE1B	ST7FLITE20 ST7FLITE25 ST7FLITE29	ST7FLITE30 ST7FLITE35 ST7FLITE39	ST72F260G1 ST72F262G1 ST72F262G2 ST72F264G1 ST72F264G2	ST72F561(R/J/K)9 ST72F561(R/J/K)6	ST7FLITES2 ST7FLITES5
ADC	10-bit	8-bit	8-bit	10-bit	10-bit	10-bit	8-bit	10-bit	10-bit	10-bit	10-bit	10-bit	8-bit
SCI	X	X		X	X	X				X	X	X	
SPI	X		X	X	X	X	X	X	X	X	X	X	X
I2C (Master & Slave)		X	X	X	X						X		
Timer (16-bit timer)		X	X	X	X	X					X	X	
Timer8 (8-bit Timer)												X	
LT (8-bit LiteTimer)							X	X	X	X			X
PWMART	X			X	X							X	
LART (12-bit ART)							X	X	X	X			X
TBU	X												
WDG	X	X	X	X	X	X		X	X	X	X	X	X
ITC	X	X	X	X	X	X	X	X	X	X	X	X	X
MCC				X	X	X	X	X	X	X	X	X	X
EEPROM							X	X	X	X			
I/O	X	X	X	X	X	X	X	X	X	X	X	X	X
CAN				1)								X	

Note:

1. This software library supports only beCAN (basic extended 2.0b active CAN cell) which is found, for example, in the ST72F561 devices. The ST72F521 device has a pCAN peripheral (2.0b passive CAN cell) and therefore is not supported.

11 REVISION HISTORY

Date	Revision	Main changes
27-Oct-05	4.0	Support given for ST72325 and ST7232A devices Section 3.2 on page 8, new hardware tools added Support given for WDG in LITE3 devices

Revision History

THE PRESENT MANUAL WHICH IS FOR GUIDANCE ONLY AIMS AT PROVIDING CUSTOMERS WITH INFORMATION REGARDING THEIR PRODUCTS IN ORDER FOR THEM TO SAVE TIME. AS A RESULT, STMICROELECTRONICS SHALL NOT BE HELD LIABLE FOR ANY DIRECT, INDIRECT OR CONSEQUENTIAL DAMAGES WITH RESPECT TO ANY CLAIMS ARISING FROM THE CONTENT OF SUCH A MANUAL AND/OR THE USE MADE BY CUSTOMERS OF THE INFORMATION CONTAINED HEREIN IN CONNEXION WITH THEIR PRODUCTS.

Information furnished is believed to be accurate and reliable. However, STMicroelectronics assumes no responsibility for the consequences of use of such information nor for any infringement of patents or other rights of third parties which may result from its use. No license is granted by implication or otherwise under any patent or patent rights of STMicroelectronics. Specifications mentioned in this publication are subject to change without notice. This publication supersedes and replaces all information previously supplied. STMicroelectronics products are not authorized for use as critical components in life support devices or systems without express written approval of STMicroelectronics.

The ST logo is a registered trademark of STMicroelectronics.

All other names are the property of their respective owners

© 2005 STMicroelectronics - All rights reserved

STMicroelectronics group of companies

Australia – Belgium - Brazil - Canada - China – Czech Republic - Finland - France - Germany - Hong Kong - India - Israel - Italy - Japan - Malaysia - Malta - Morocco - Singapore - Spain - Sweden - Switzerland - United Kingdom - United States of America

www.st.com

AMEYA360

Components Supply Platform

Authorized Distribution Brand :



Website :

Welcome to visit www.ameya360.com

Contact Us :

➤ Address :

401 Building No.5, JiuGe Business Center, Lane 2301, Yishan Rd
Minhang District, Shanghai , China

➤ Sales :

Direct +86 (21) 6401-6692

Email amall@ameya360.com

QQ 800077892

Skype [ameyasales1](#) [ameyasales2](#)

➤ Customer Service :

Email service@ameya360.com

➤ Partnership :

Tel +86 (21) 64016692-8333

Email mkt@ameya360.com