

THE INFORMATION CONTAINED HEREIN IS CONSIDERED "PROPRIETARY" TO BEL FUSE INC. AND SHALL NOT BE COPIED, REPRODUCED OR DISCLOSED WITHOUT THE WRITTEN APPROVAL OF BEL FUSE INC.

RoHS
2002/95/EC



LED 2 & 4 POLARITY			LED 1 & 3 POLARITY		
PIN 11	PIN 12	COLOR	PIN 13	PIN 14	COLOR
-	+	YELLOW	-	+	YELLOW
+	-	GREEN	+	-	GREEN

ELECTRICAL CHARACTERISTICS @ 25°C

URNS RATIO

TP1	1CT : 1CT ±2%
TP2	1CT : 1CT ±2%
TP3	1CT : 1CT ±2%
TP4	1CT : 1CT ±2%

QCL @ 100kHz/100mVRMS

8mA DC BIAS 350µH MIN.

INS. LOSS

0.1MHz TO 1MHz	-1.1 dB MAX
1MHz TO 65MHz	-0.5 dB MAX
65MHz TO 100MHz	-0.8 dB MAX
100MHz TO 125MHz	-1.2 dB MAX

RET. LOSS (MIN)

0.5MHz-40MHz	-18 dB
40MHz-100MHz	-12+20LOG(f/80MHz) dB

CM TO CM REJ

100kHz - 100MHz -30 dB MIN

CM TO DM REJ

100kHz - 100MHz -35 dB MIN

HIPOT (Isolation Voltage):

1500 Vrms

100% OF PRODUCTION TESTED TO COMPLY WITH IEEE 802.3 ISOLATION REQUIREMENT

LEDS 1, 2, 3 AND 4

VF (FORWARD VOLTAGE)	IF=20mA GREEN 2.2V TYP.
	IF=20mA YELLOW 2.1V TYP.
λD (DOMINANT WAVELENGTH)	IF=20mA GREEN 565nm TYP.
	IF=20mA YELLOW 590nm TYP.

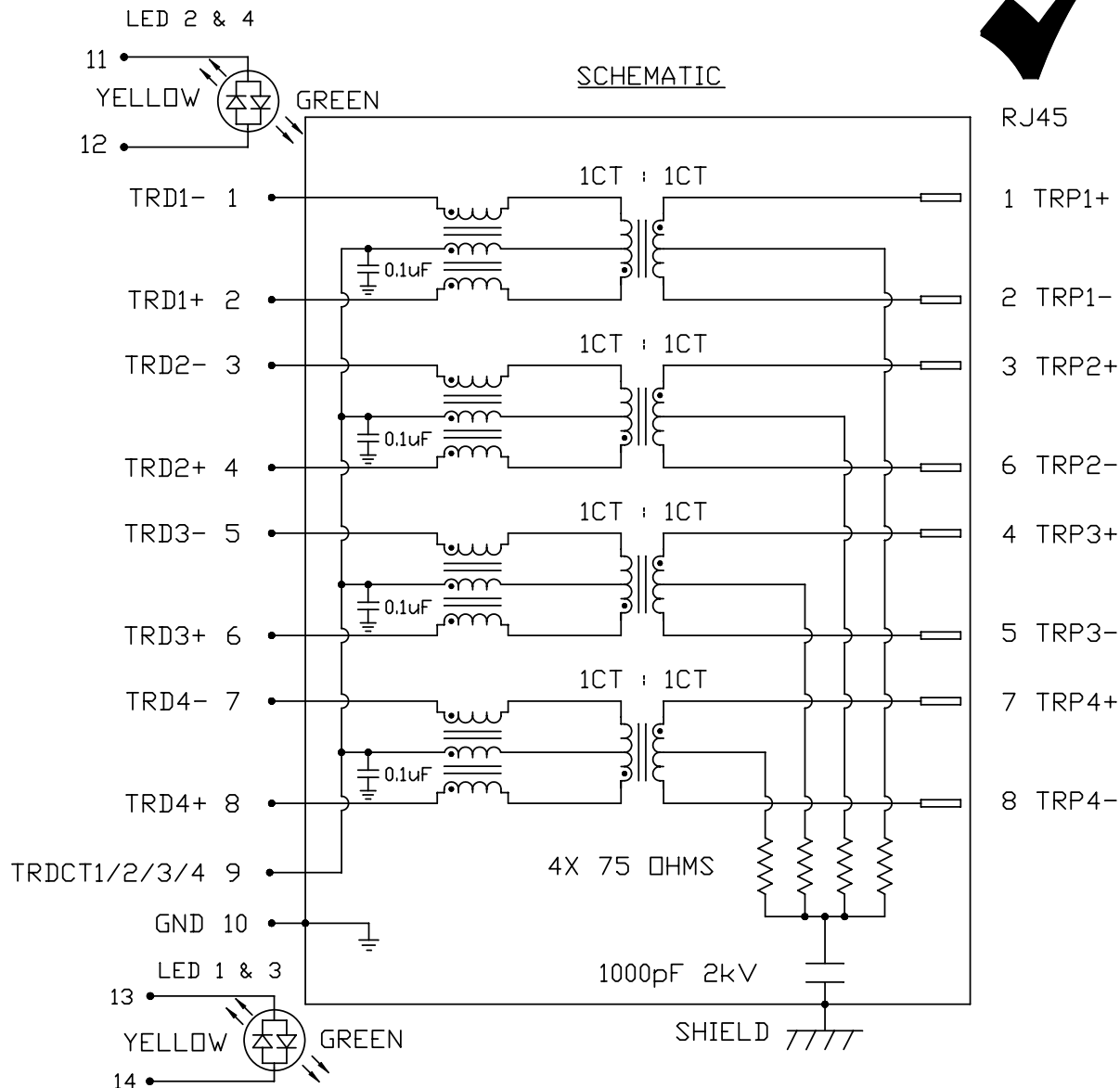

ORIGINATED BY	DATE
CHOW WANGCHUNG	05-05-10
DRAWN BY	DATE
LEE WEIDE	05-05-10

TITLE	2X6 gigabit MagJack® WITH UPPER AND LOWER LED (8 Cores) PATENTED
-------	---

PART NO. / DRAWING NO.	0879-2C6R-54
FILE NAME	0879-2C6R-54_D.DWG

STANDARD DIM.	TOL. IN INCH
.X	
.XX	
.XXX	

[] METRIC DIM. AS REFERENCE	REV. : D
UNIT : INCH [mm]	SIZE : A4
SCALE : N/A	PAGE : 2



THE INFORMATION CONTAINED HEREIN IS CONSIDERED "PROPRIETARY" TO BEL FUSE INC. AND SHALL NOT BE COPIED, REPRODUCED OR DISCLOSED WITHOUT THE WRITTEN APPROVAL OF BEL FUSE INC.

RoHS
2002/95/EC

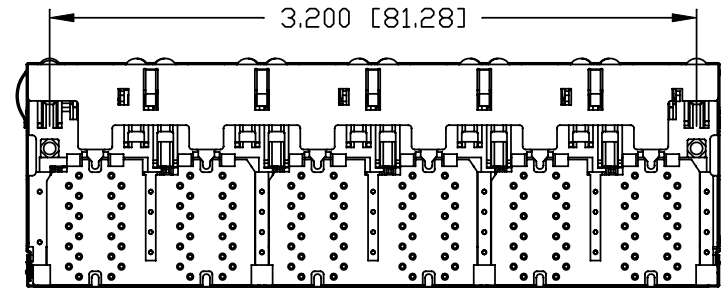
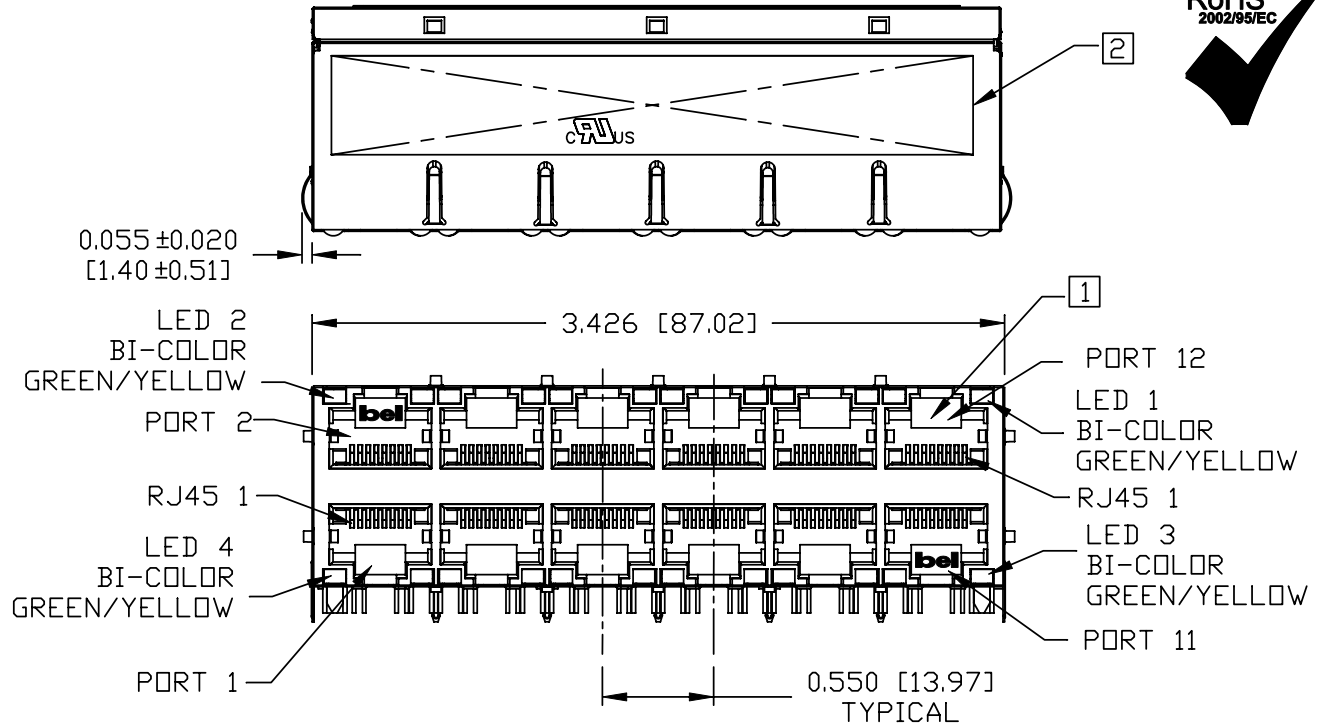
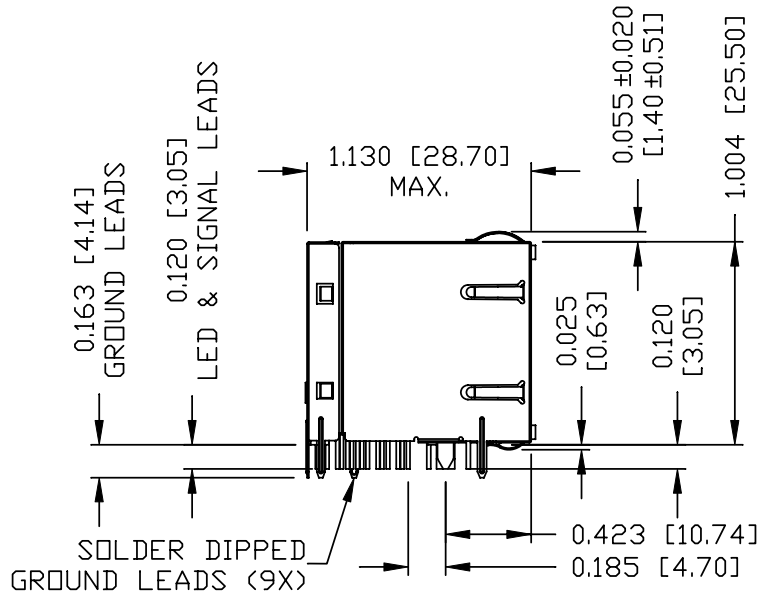

NOTES:

- PLASTIC HOUSING: THERMOPLASTIC PBT
FLAMMABILITY RATING UL 94V-0
- CONTACT PLATING: 50 MICRO-INCH HARD GOLD PLATING
- OUTPUT PINS: TIN-COATED COPPER WIRE, DIA 0.018 INCH.
- METAL SHIELD: NICKEL PLATED ON COPPER ALLOY.
(ALL GROUND LEADS ARE SOLDER DIPPED)

- [1] JACK CAVITY CONFORMS TO FCC RULES AND REGULATIONS, PART 68 SUBPART F.
- [2] MARK PART WITH MFG LOGO, MFG NAME, PART NUMBER, DATE CODE AND PATENTED.
3. RoHS COMPLIANCE, PER EU DIRECTIVE 2002/95/EC.

c UL RECOGNIZED - FILE #E196366 AND E169987.

4. THE PRODUCT IS PATENTED, THE PATENT NUMBER ARE U.S. PAT. 5,736,910 AND U.S. PAT. 6,840,817 AND U.S. PAT. 7,123,117.

ORIGINATED BY CHEN BILL	DATE 05-05-10	TITLE 2X6 gigabit MagJack® WITH UPPER AND LOWER LED (8 Cores) PATENTED	PART NO. / DRAWING NO. 0879-2C6R-54	STANDARD DIM. TOL. IN INCH	[] METRIC DIM. AS REFERENCE		
					UNIT : INCH [mm]	REV. : D	
DRAWN BY XIAN JIAXIN	DATE 05-05-10		FILE NAME 0879-2C6R-54_D.DWG	.X	SCALE : N/A	SIZE : A4	
				.XX			
				.XXX ±0.010		PAGE : 3	

THE INFORMATION CONTAINED HEREIN IS CONSIDERED "PROPRIETARY" TO BEL FUSE INC. AND SHALL NOT BE COPIED, REPRODUCED OR DISCLOSED WITHOUT THE WRITTEN APPROVAL OF BEL FUSE INC.

RoHS
2002/95/EC

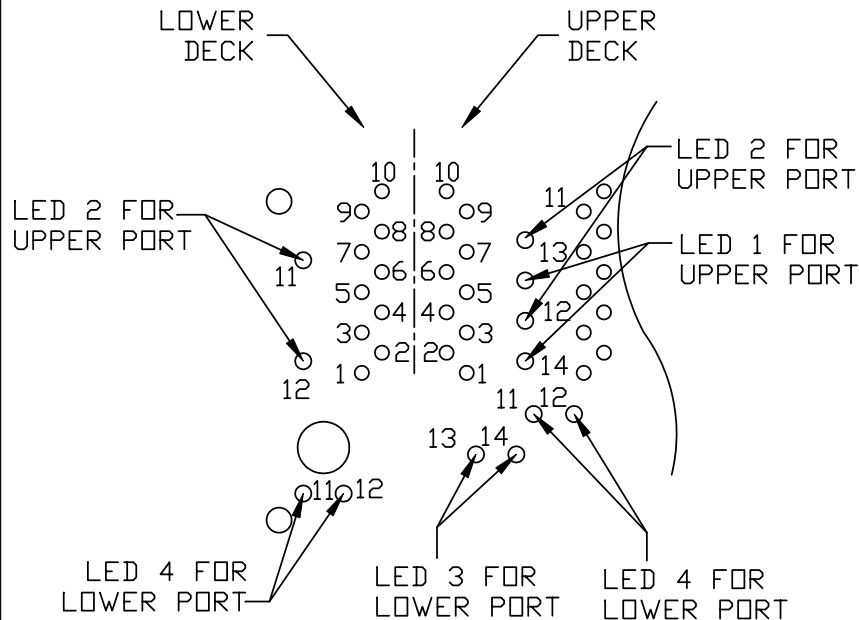

PIN-OUT INFORMATION
(COMPONENT SIDE VIEW)

10	GND
9	TRDCT1/2/3/4
8	TRD 4+
7	TRD 4-
6	TRD 3+
5	TRD 3-
4	TRD 2+
3	TRD 2-
2	TRD 1+
1	TRD 1-

PORT ASSIGNMENT
(COMPONENT SIDE VIEW)

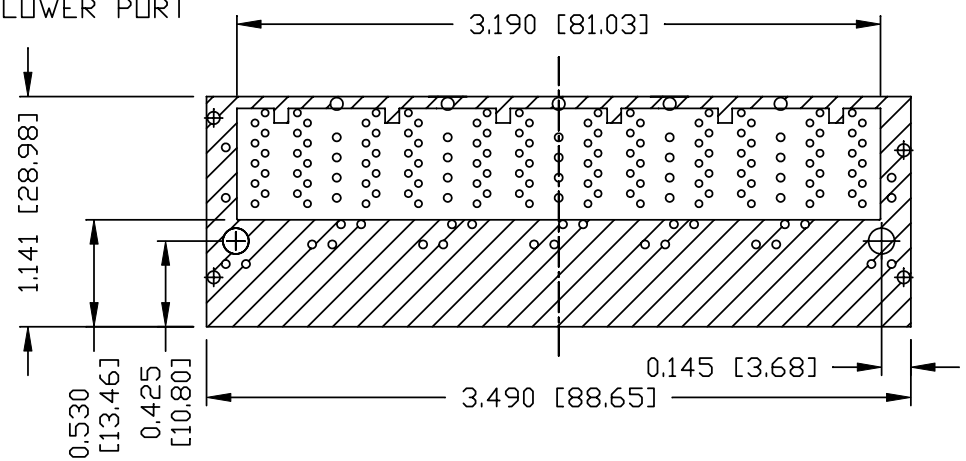
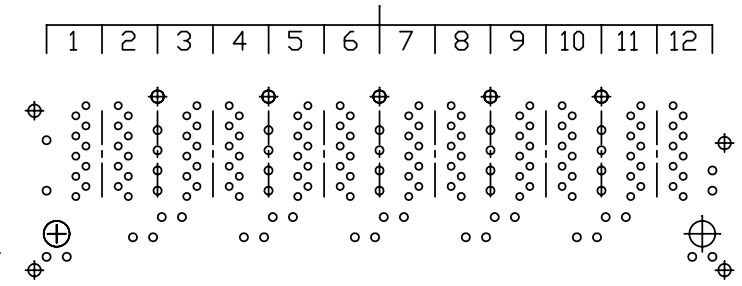

THE SHADED AREA ON THE CUSTOMER BOARD ARE RECOMMENDED TO BE CLEAR OFF ANY VIA HOLE OR COMPONENT PAD.

ORIGINATED BY	DATE
CHEN BILL	05-05-10
DRAWN BY	DATE
XIAN JIAXIN	05-05-10

TITLE
2X6 gigabit MagJack®
WITH UPPER AND LOWER LED
(8 Cores)
PATENTED

PART NO. / DRAWING NO.
0879-2C6R-54
FILE NAME
0879-2C6R-54_D.DWG

STANDARD DIM.	[] METRIC DIM. AS REFERENCE
TOL. IN INCH	UNIT : INCH [mm]
.X	REV. : D
.XX	SCALE : N/A
.XXX	±0.004

UNIT : INCH [mm]	REV. : D
SCALE : N/A	SIZE : A4
⊕ - - - ⊖	PAGE : 4



THE INFORMATION CONTAINED HEREIN IS CONSIDERED "PROPRIETARY" TO BEL FUSE INC. AND SHALL NOT BE COPIED, REPRODUCED OR DISCLOSED WITHOUT THE WRITTEN APPROVAL OF BEL FUSE INC.

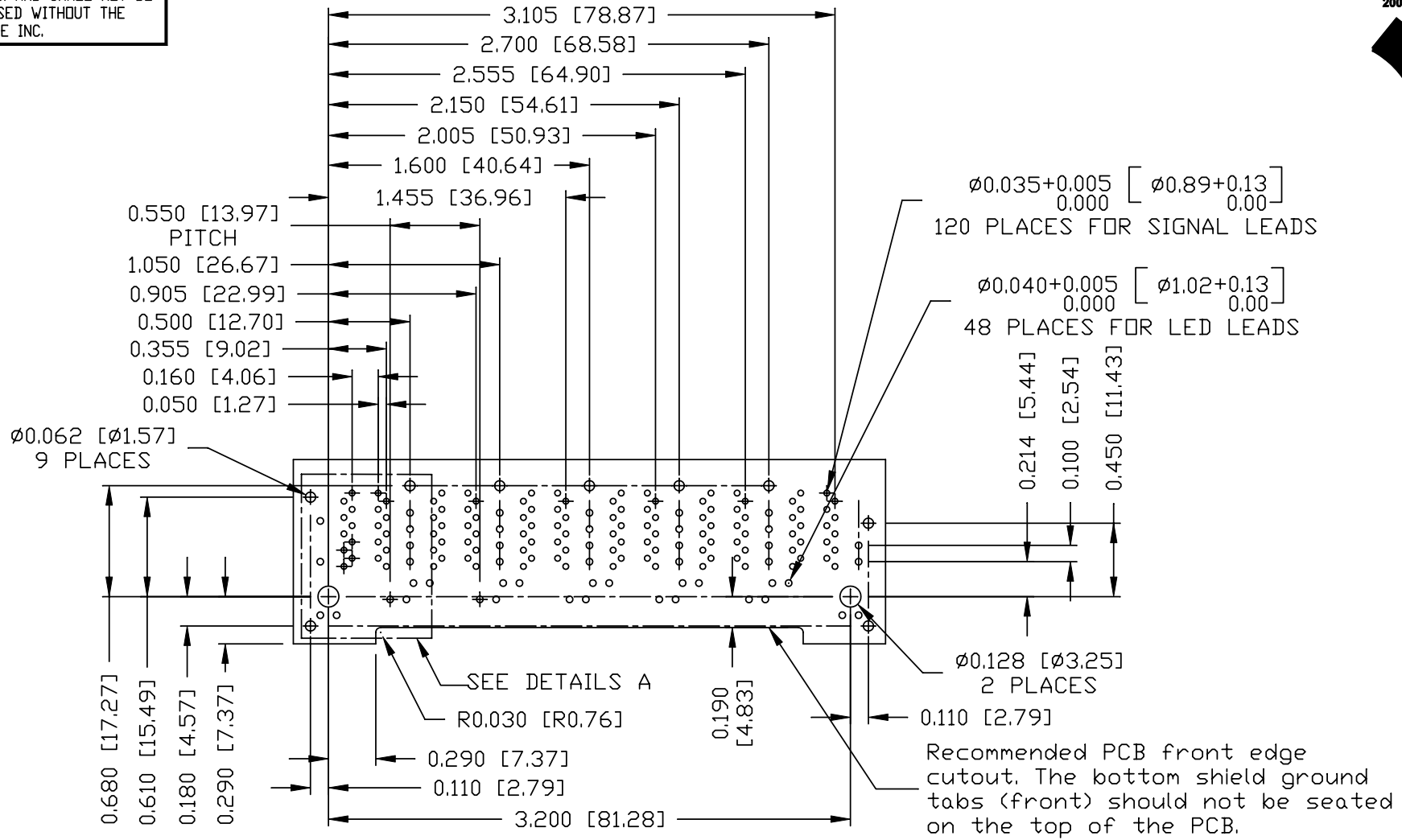

SUGGESTED FOOTPRINT
(COMPONENT SIDE VIEW)

ORIGINATED BY CHEN BILL	DATE 05-05-10	TITLE 2X6 gigabit MagJack® WITH UPPER AND LOWER LED (8 Cores) PATENTED	PART NO. / DRAWING NO. 0879-2C6R-54	STANDARD DIM. TOL. IN INCH		[] METRIC DIM. AS REFERENCE		bel COMPONENTS FOR A CONNECTED PLANET
	DRAWN BY XIAN JIAXIN			DATE 05-05-10	FILE NAME 0879-2C6R-54_D.DWG	.X .XX .XXX	±0.004	

THE INFORMATION CONTAINED HEREIN IS CONSIDERED "PROPRIETARY" TO BEL FUSE INC. AND SHALL NOT BE COPIED, REPRODUCED OR DISCLOSED WITHOUT THE WRITTEN APPROVAL OF BEL FUSE INC.

RoHS
2002/95/EC

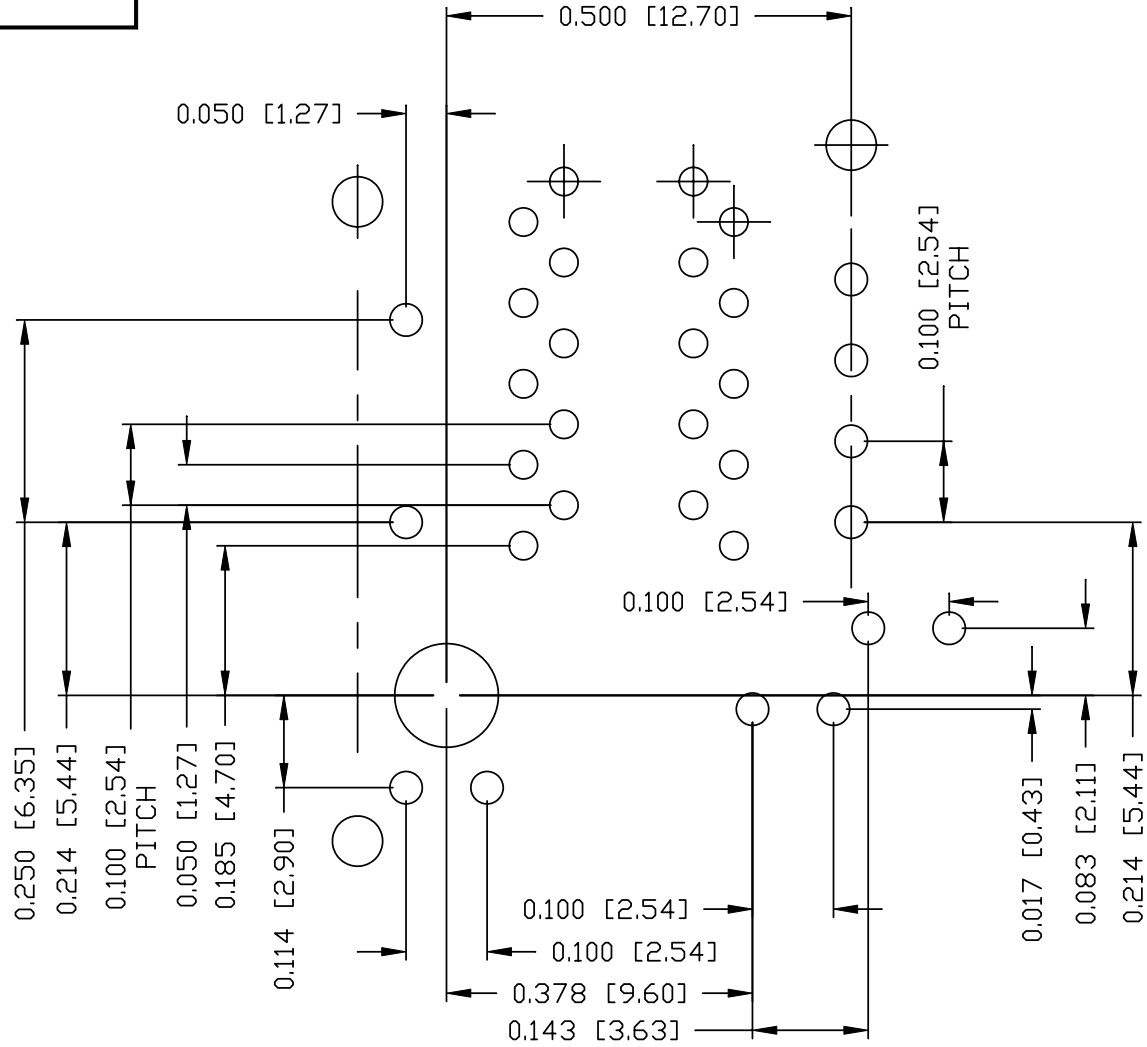

DETAILS A

ORIGINATED BY	DATE	TITLE 2X6 gigabit MagJack® WIHT UPPER AND LOWER LED (8 Cores)	PART NO. / DRAWING NO.	STANDARD DIM. TOL. IN INCH	[] METRIC DIM. AS REFERENCE	
CHEN BILL	05-05-10		0879-2C6R-54	.X	UNIT : INCH [mm]	REV. : D
DRAWN BY	DATE		FILE NAME	.XX	SCALE : N/A	SIZE : A4
XIAN JIAXIN	05-05-10		0879-2C6R-54_D.DWG	.XXX	±0.004	PAGE : 6



THE INFORMATION CONTAINED HEREIN IS CONSIDERED "PROPRIETARY" TO BEL FUSE INC. AND SHALL NOT BE COPIED, REPRODUCED OR DISCLOSED WITHOUT THE WRITTEN APPROVAL OF BEL FUSE INC.

RoHS
2002/95/EC



SUGGESTED PANEL OPENING

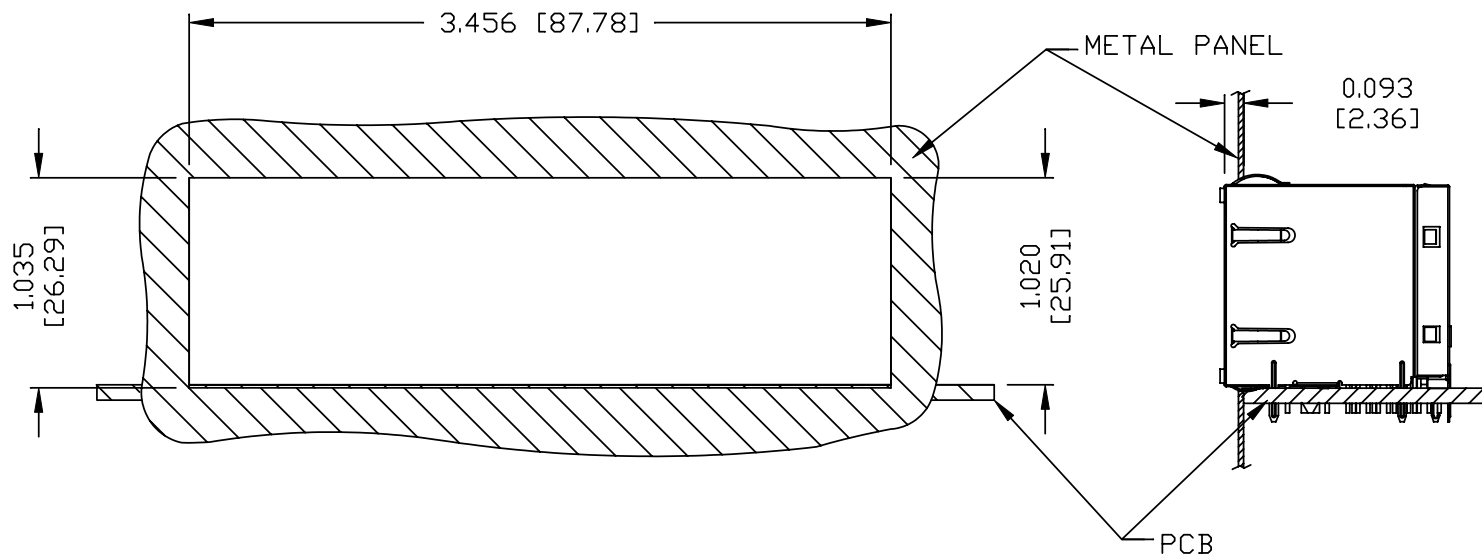

NOTE:

THE DISTANCE OF PANEL INSIDE SURFACE RELATIVE TO FRONT SURFACE OF PART IS ONLY A SUGGESTION. IN CASE THIS DISTANCE IS DIFFERENT, THE REQUIRED PANEL OPENING DIMENSIONS CHANGE ACCORDINGLY.

PACKING INFORMATION

PACKING TRAY : 0200-9999-P3 (TOP)
0200-9999-P4 (BOTTOM)

PACKING QUANTITY : 14 PCS FINISHED GOODS PER TRAY
7 TRAYS (98 PCS FINISHED GOODS) PER CARTON BOX

NOTE : CARDBOARDS ARE PLACED BETWEEN LAYERS OF PACKING TRAY INSIDE CARTON BOX
(INCLUDE THE UPPERMOST AND LOWERMOST TRAY)

ORIGINATED BY CHEN BILL	DATE 05-05-10	TITLE 2X6 gigabit MagJack® WITH UPPER AND LOWER LED (8 Cores) PATENTED	PART NO. / DRAWING NO. 0879-2C6R-54	STANDARD DIM. TOL. IN INCH		[] METRIC DIM. AS REFERENCE		bel
	DRAWN BY XIAN JIAXIN			DATE 05-05-10	FILE NAME 0879-2C6R-54_D.DWG	.X .XX .XXX	±0.004	

AMEYA360

Components Supply Platform

Authorized Distribution Brand :



Website :

Welcome to visit www.ameya360.com

Contact Us :

➤ Address :

401 Building No.5, JiuGe Business Center, Lane 2301, Yishan Rd
Minhang District, Shanghai , China

➤ Sales :

Direct +86 (21) 6401-6692

Email amall@ameya360.com

QQ 800077892

Skype [ameyasales1](#) [ameyasales2](#)

➤ Customer Service :

Email service@ameya360.com

➤ Partnership :

Tel +86 (21) 64016692-8333

Email mkt@ameya360.com