

Vertical Cavity Surface Emitting Laser in T-1 Package

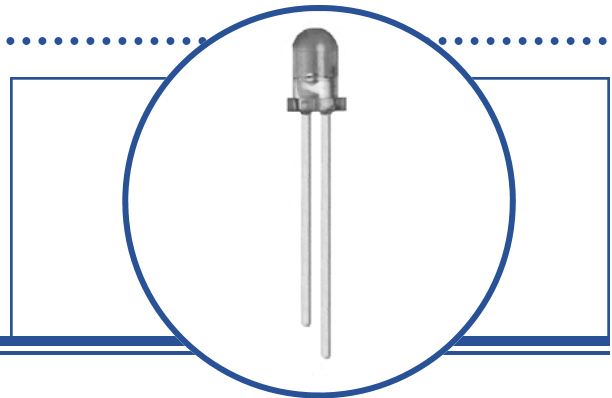

OPV332

- 850nm VCSEL technology
- High thermal stability
- Low drive current
- High output power
- Narrow Beam Angle



The OPV332 is a Vertical Cavity Surface Emitting Laser (VCSEL) packaged in a dome lens T-1 package. VCSELs offer many advantages in sensing applications when compared to infrared LEDs. These devices require substantially lower drive currents to obtain the same amount of output power as LEDs. This feature allows VCSELs to be used in low power consumption applications such as battery operated equipment.

The dome lens packaging creates a narrow 4 degree beam angle from the device. Long distance applications may benefit from this feature as secondary optics may be eliminated, reducing total system cost. The OPV332 is optically and spectrally compatible with Optek's standard detector products such as the OP500 series phototransistors, OP530 series photodarlingtons and the OP900 series photodiodes.

Applications

- Non-contact position sensing
- Photoelectric sensors
- Optical encoders
- Light curtains

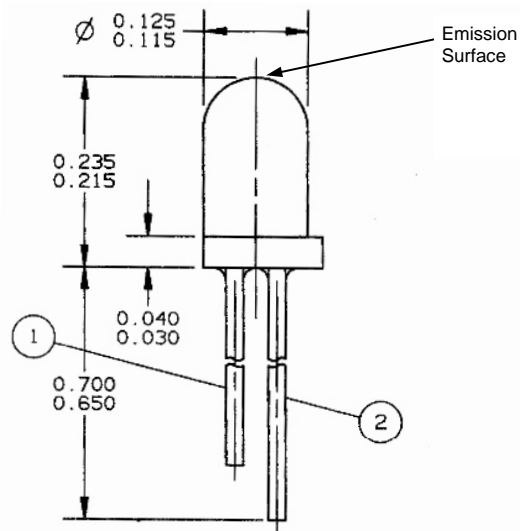

Additional laser safety information can be found on the Optek website. See application bulletin #221. Classification is not marked on the device due to space limitations. See package outline for centerline of optical radiance. Operating devices beyond maximum rating may result in hazardous radiation exposure.

VCSEL

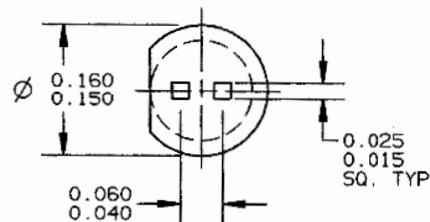
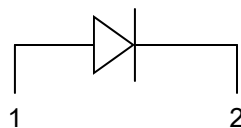

LEAD FREE

Optek reserves the right to make changes at any time in order to improve design and to supply the best product possible.

OPTEK Technology Inc.— 1645 Wallace Drive, Carrollton, Texas 75006
Phone: (800) 341-4747 FAX: (972) 323-2396 sensors@optekinc.com www.optekinc.com



A subsidiary of
TT electronics plc

VCSEL in T-1 Package

OPV332



Absolute Maximum Ratings

$T_A = 25^\circ\text{C}$ unless otherwise noted

Storage Temperature Range	-40° to +100° C
Operating Temperature Range	0° to +85° C
Lead Soldering Temperature [1/16 inch (1.6mm) from case for 5 sec with soldering iron]	260° C ⁽¹⁾
Maximum Forward Peak Current, Continuous	12 mA
Maximum Reverse Voltage	5 V
Maximum Forward Current, pulse (1 μ s P.W., 10% D.C.)	48 mA

Electrical Characteristics ($T_A = 25^\circ\text{C}$ unless otherwise noted)

SYMBOL	PARAMETER	MIN	TYP	MAX	UNITS	CONDITIONS
P_{OT}	Total Power Out	1.5			mW	$I_F = 7\text{ mA}$
I_{TH}	Threshold Current			3.0	mA	Note 2
V_F	Forward Voltage			2.2	V	$I_F = 7\text{ mA}$
I_R	Reverse Current			100	nA	$V_R = 5\text{ V}$
R_S	Series Resistance	20		55	ohms	Note 3
η	Slope Efficiency	0.28			mW/mA	Note 4
λ	Wavelength	840		860	nm	
$\Delta\lambda$	Optical Bandwidth			0.85	nm	
θ	Beam Divergence		4		Degrees	FWHM
$\Delta\eta/\Delta T$	Temp Coefficient of Slope Efficiency		-0.50		%/°C	(0° - 70°C), Note 4
$\Delta\lambda/\Delta T$	Temp Coefficient of Wavelength		0.06		nm/°C	(0° - 70°C)
ΔI_{TH}	Temp Variance of Threshold Current		± 1.0		mA	(0° - 70°C), Note 2
$\Delta V_F/\Delta T$	Temp Coefficient for Forward Voltage		-2.5		mV/°C	(0° - 70°C)

NOTES:

- (1) RMA flux is recommended. Solder dwell time can be increased to 10 seconds when flow soldering.
- (2) Threshold Current is based on the two line intersection method specified in Telcordia GR-468-Core. Line 1 from 4 mA to 6 mA. Line 2 from 0 mA to 0.5 mA.
- (3) Series Resistance is the slope of the Voltage-Current line from 5 to 8 mA.
- (4) Slope efficiency, is the slope of the best fit LI line from 5 mA to 8 mA with 0.25mA test intervals.

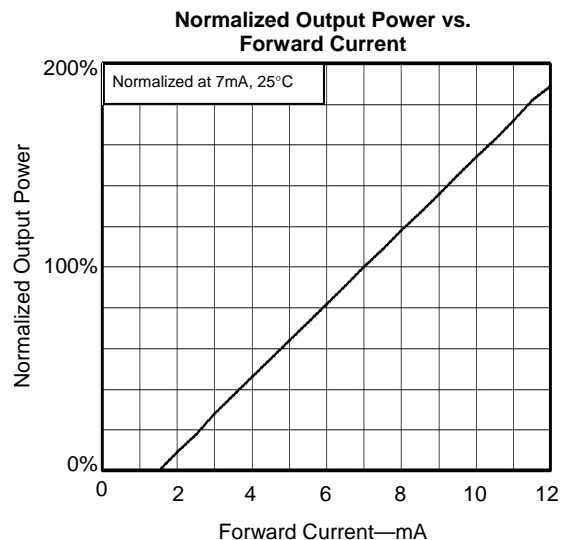
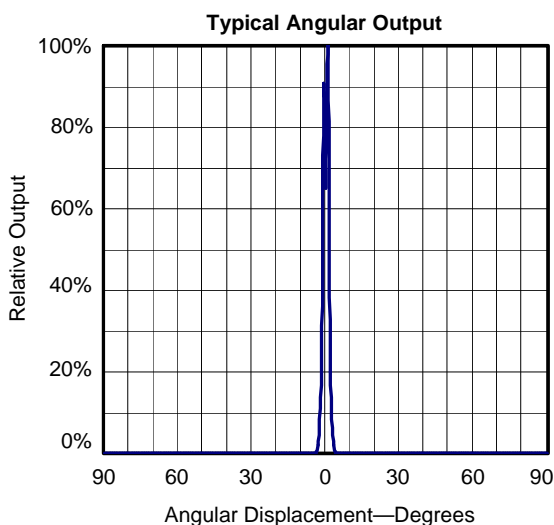

AMEYA360

Components Supply Platform

Authorized Distribution Brand :



Website :

Welcome to visit www.ameya360.com

Contact Us :

➤ Address :

401 Building No.5, JiuGe Business Center, Lane 2301, Yishan Rd
Minhang District, Shanghai , China

➤ Sales :

Direct +86 (21) 6401-6692

Email amall@ameya360.com

QQ 800077892

Skype [ameyasales1](#) [ameyasales2](#)

➤ Customer Service :

Email service@ameya360.com

➤ Partnership :

Tel +86 (21) 64016692-8333

Email mkt@ameya360.com