

## Introduction

Today's high performance microprocessors present many challenges to their power source. High power consumption, low bus voltages, and fast load changes are the principal characteristics which have led to the need for a switch mode DC-DC converter local to the microprocessor.

Intel has specified a Voltage Regulator Module (VRM) for the Pentium Pro microprocessor [1]. This specification details the requirements imposed upon the input power source(s) by the Pentium Pro and provides the computer industry with a standard DC-DC converter solution. The Intersil HIP6002 and HIP6003 pulse width modulator (PWM) controllers are targeted specifically for DC-DC converters powering the Pentium Pro and similar high performance microprocessors. The HIP6004 and HIP6005 PWM controllers are enhanced versions of the HIP6002 and HIP6003, with additional features specifically for next generation microprocessors, including Intel's Pentium II processor.

## Intersil HIP6004 and HIP6005

The Intersil HIP6004 and HIP6005 are voltage mode controllers with many functions needed for high performance processors. Figure 1 shows a simple block diagram of the HIP6004 and HIP6005. Each contains a high performance error amplifier, a high-resolution 5-bit digital-to-analog converter (DAC), a programmable free running oscillator, and protection circuitry. The HIP6004 has two MOSFET drivers for use in synchronous rectified Buck converters. The HIP6005 omits the lower MOSFET driver for standard Buck configurations. A more complete description of the parts can be found in their data sheets [2, 3].

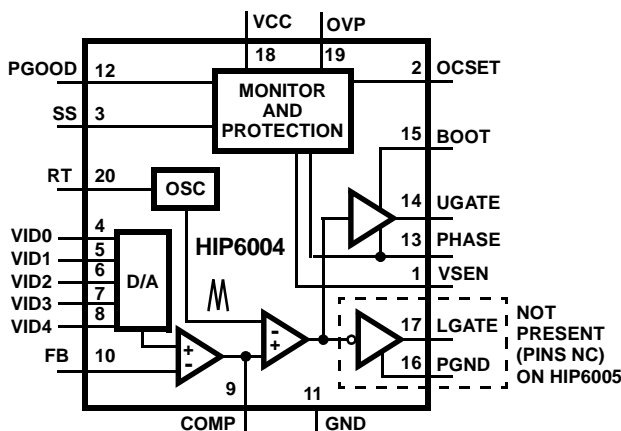

FIGURE 1. BLOCK DIAGRAM OF HIP6004 AND HIP6005

## HIP6004/5 Reference Designs

The HIP6004/5EVAL3 is an evaluation board which highlights the operation of the HIP6004 or the HIP6005 in an embedded motherboard application. The evaluation board can be configured as either a synchronous Buck (HIP6004EVAL3) or standard Buck (HIP6005EVAL3) converter.

### Common Features

- Operates in +5V or +12V Input Systems
- 5-Bit DAC with  $\pm 1\%$  Accuracy
- Overvoltage Protection via SCR and Fuse
- Overcurrent Protection
- Embedded Converters with Connector to accept Microprocessor Test Tool

### HIP6004EVAL3

The HIP6004EVAL3 is a synchronous Buck converter capable of providing up to 14A of current at output voltages from 1.3V to 3.5V. The schematic and bill-of-materials for this design can be found in the appendix. The HIP6004EVAL3 is very similar to the HIP6002EVAL1, which is described in Intersil Application Note AN9668 [4]. The HIP6004EVAL3 contains additional input and output capacitors for more robust performance at processor load currents up to 14A.

### Efficiency

Figure 2 displays the HIP6004EVAL3 efficiency versus load current for both 5V and 12V inputs and a 2.8V output with 100 linear feet per minute (LFM) of airflow. The converter efficiency is equal to the output power divided by the input power, which consists of the output power plus losses. For a given input voltage and load condition, the losses are roughly constant with variations of output voltage. Thus, the efficiency is lower when the converter output voltage is lower. This can be seen when comparing Figure 2 in this application note to Figure 3 in AN9668.

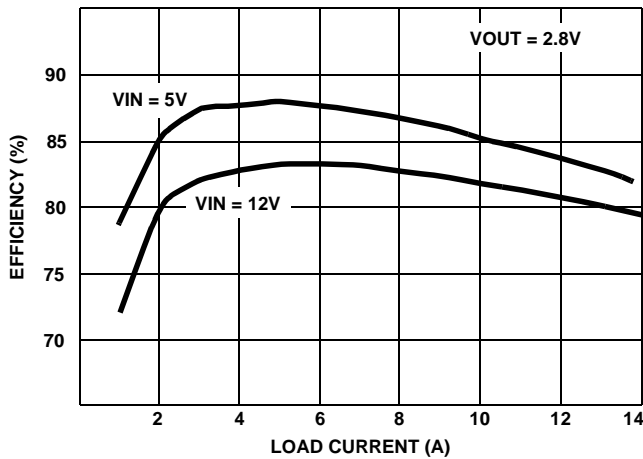

FIGURE 2. HIP6004EVAL3 EFFICIENCY vs LOAD

For a given output voltage and load, the efficiency is lower at higher input voltages. This is due primarily to higher MOSFET switching losses and is displayed in Figure 2.

**Transient Response**

Figures 3 and 4 show laboratory oscillograms of the HIP6004EVAL3 in response to a load transient application. The load transient applied is from 0A to 14A for both figures. In Figure 3, the transient is applied using an Intel test tool which emulates the actual dynamic performance of the Pentium II and other future processors. Slew rates approach 30A/μs. The input voltage is 12V and the output voltage is programmed to 2.05V for this case.

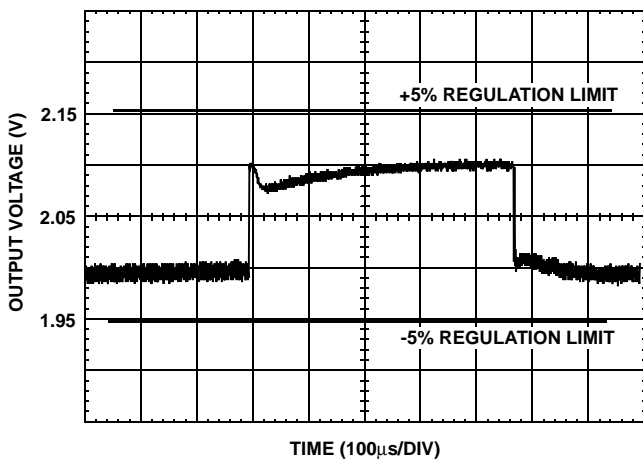

FIGURE 3. HIP6004EVAL3 TRANSIENT RESPONSE TO INTEL TEST TOOL

Due to the analog nature of the HIP600x VID pins (see HIP6004 data sheet for details), the 5 VID pins must be grounded by installing jumpers JP0-4 on the evaluation board when the Intel test tool is used. This programs the converter output voltage to 2.05V, which is lower than present microprocessors require. However, the intent of using the Intel test tool is to validate the DC-DC converter

design under worst-case transient loads. Testing the dynamic performance of the converter at 2.05V is more severe than at a higher output voltage and therefore still provides pertinent information.

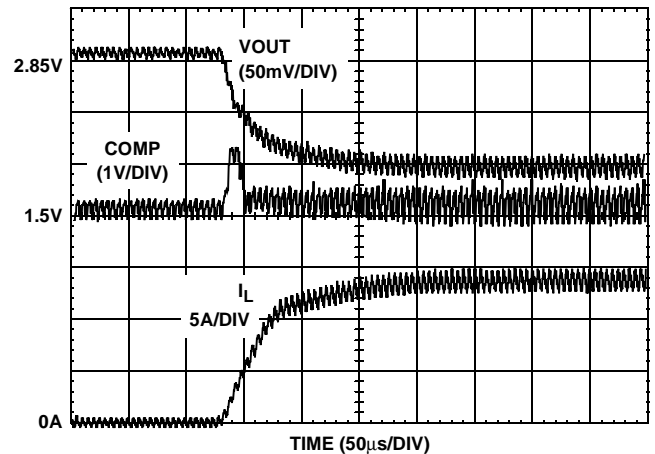

FIGURE 4. 0A TO 14A LOAD TRANSIENT RESPONSE

Figure 3 shows that the output voltage remains well within the ±5% regulation window, even at the more stringent 2.05V output. The additional margin allows for temperature, life, and sample variations. Figure 4 details the positive edge of the load transient application, but with different conditions. The 0A to 14A load transient was applied with a Hewlett Packard active load (HP6060B), which is limited to about 1A/μs slew rate. In this case, the output voltage is programmed to a more typical value of 2.8V. The converter performance is very similar for both test conditions. Since the slew rate of the transient is slower in Figure 4, the output voltage drops at a slower rate but the amount of the voltage excursion is about the same. In addition to the output voltage, Figure 4 shows the error amplifier output (COMP) and the output inductor current (IL). Notice the rapid response of the error amplifier.

**HIP6005EVAL3**

The HIP6005EVAL3 is a standard Buck converter capable of providing up to 14A of current at output voltages from 1.3V to 3.5V. The schematic and bill-of-materials for this design can be found in the appendix. The HIP6005EVAL3 differs from the HIP6004EVAL3 in three ways:

1. U1 is a HIP6005
2. CR3 replaces Q2 and CR2 is changed
3. L2 is a larger inductor

**Efficiency**

Figure 5 shows the efficiency data for the HIP6005EVAL3 under identical conditions as Figure 2 for the HIP6004EVAL3. Comparing the two graphs reveals that the Synchronous-Buck design is a little more efficient than the Standard-Buck design over most of the load range.

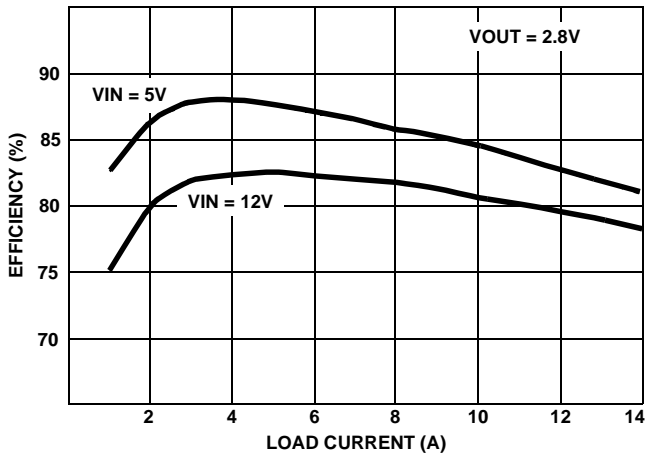

FIGURE 5. HIP6005EVAL3 EFFICIENCY vs LOAD

**Transient Response**

Figures 6 and 7 show laboratory oscillograms of the HIP6005EVAL3 which are similar to those shown in Figures 3 and 4 for the HIP6004EVAL3. There are small differences in the transient responses of the two different evaluation boards. Since the HIP6005EVAL3 uses a larger output inductor and identical control loop compensation (R5, R8, C8, and C9), the closed-loop gain crossover frequency is lower than for the HIP6004EVAL3. Check the *Feedback Compensation* section of either data sheet for details on loop compensation design. Table 1 details simulated closed-loop bandwidth and phase margin for both reference boards at both +5V and +12V input sources.

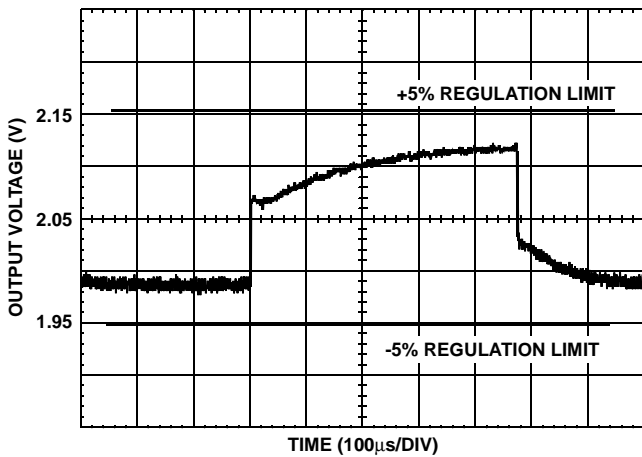

FIGURE 6. HIP6005EVAL3 TRANSIENT RESPONSE TO INTEL TEST TOOL

TABLE 1. CONTROL LOOP CHARACTERISTICS

	HIP6004EVAL3		HIP6005EVAL3	
	IN = 5V	IN = 12V	IN = 5V	IN = 12V
f <sub>0dB</sub>	37kHz	74kHz	23kHz	48kHz
φMARGIN	68°	54°	74°	64°

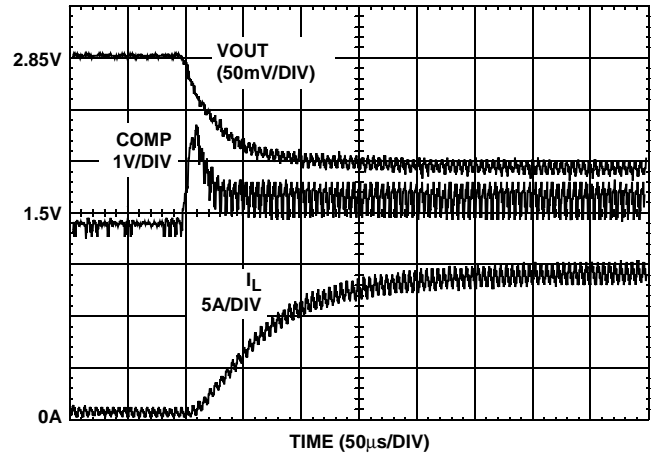

FIGURE 7. 0A TO 14A LOAD TRANSIENT RESPONSE

**Output Voltage Droop with Load**

Both the HIP6004EVAL3 and HIP6005EVAL3 use a droop function to maintain output voltage regulation through load transients with fewer (or less costly) output capacitors. With a high di/dt load transient typical of the Pentium Pro microprocessor, the largest deviation of the output voltage is at the leading edge of the transient. The droop function adds a voltage change as a function of load that counters the transient deviation.

Figure 8 illustrates the static-load droop characteristic. With no-load the output voltage is above the nominal output level. The output decreases (or droops) as the load increases.

With a dynamic load, the droop function pre-biases the output voltage to minimize the total deviation. Prior to the application of load, the output voltage is above the nominal level and the transient deviation results in an output lower than the nominal level. Figure 3 illustrates the droop function performance on the HIP6004EVAL3 converter. The transient deviation is approximately 110mV. At light load, the output voltage is about 50mV higher than the nominal output voltage of 2.05V. At full load, the output voltage is about 60mV lower than nominal. The total deviation is within ±60mV with the droop function compared to a deviation of over ±100mV without this function. Since the voltage excursions at the transient edges are mainly a function of the output capacitors, the converter uses fewer capacitors.

The HIP6004/5EVAL3 implements the droop function by using the average voltage drop across the output inductor.

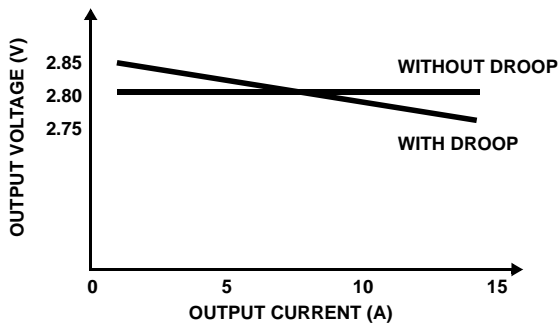

FIGURE 8. STATIC REGULATION OF THE HIP6004/5EVAL3

The average voltage drop equals the DC output current times the DC winding resistance of the output inductor. Instead of straight voltage feedback, an averaging filter (R9 and C14 in the schematics) is added around the output inductor. This filter communicates both the output voltage and droop information back to the PWM controller. A resistor (R3) increases the light-load voltage above the DAC program level.

### OC Protection

Both the HIP6004EVAL3 and HIP6005EVAL3 have lossless overcurrent (OC) protection. This is accomplished via the current-sense function of the HIP600x family. The HIP6004 and HIP6005 sense converter load current by monitoring the drop across the upper MOSFET (Q1 in the schematics). By selecting the appropriate value of the OCSET resistor (R6), an overcurrent protection scheme is employed without the cost and power loss associated with an external current-sense resistor. See the *Over-Current Protection* section of either the HIP6004 and HIP6005 data sheet for details on the design procedure for the OCSET resistor.

### Enable Function

The HIP6004EVAL3 and HIP6005EVAL3 can be disabled by pulling the SS pin below 1.2V. A simple way to incorporate an open collector ENABLE function is shown in Figure 9.

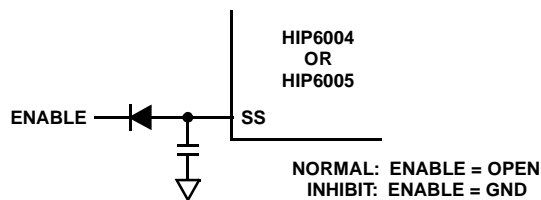

FIGURE 9. DIODE PROVIDES ENABLE FUNCTION

### Modifications for Lower Cost Solutions

The HIP6004EVAL3 and HIP6005EVAL3 reference designs are designed with adequate margins for reliable operation when powering Pentium Pro and future Intel processors. Some system designers may wish to be more aggressive with the design of the DC-DC converter to have a lower cost solution. This section describes how the evaluation boards can be tailored for lower-cost systems.

### OV Protection

The HIP6004/5EVAL3 contains circuitry to protect against output overvoltage (OV) conditions. When an overvoltage (greater than 15% over the nominal  $V_{out}$ ) occurs, the HIP6004 (or HIP6005) fires an SCR (Q3) and the input fuse will open.

For applications where this feature is not necessary, the following components may be eliminated: F1, Q3, and R4.

### Bulk Input Capacitors

The HIP6004/5EVAL3 boards use five 330 $\mu$ F aluminum electrolytic capacitors to handle the high RMS current ratings of a buck converter in a high-performance microprocessor application. Each of these capacitors is rated for about 1A of RMS current by the manufacturer. The RMS current requirement of the total bulk input capacitor is roughly equal to 1/2 of the converter load. If the average processor current draw is 10A, then five input capacitors meet this rating.

However, the capacitor manufacturer RMS current ratings are based on worst-case ESR of the capacitors and are conservative. Exceeding the current ratings may shorten the life of the capacitors, but an expected life reduction from 8 years to say 5 years, for example, may be acceptable for many applications.

With caution and working with the capacitor supplier, it may be possible to safely remove 1-2 of the bulk input capacitors. This action should be balanced by the relatively small cost savings associated with the removal of the capacitors.

### Output Capacitors

Low-ESR aluminum electrolytic capacitors are also used on the output of the converter in the HIP6004/5EVAL3. This is not the only choice for this type of application, but it is the lowest cost. Refer to the *Component Selection Guidelines* in the data sheets for additional information. Nine parallel capacitors are used to meet Intel-specified regulation of  $\pm 5\%$  over all variations including temperature, load transients, and component life. It is the load transient requirements which pose the largest challenge, as discussed earlier in this application note.

Figures 3-4 and 6-7 show that the reference designs meet  $\pm 5\%$  regulation in response to a 0A-14A load transient with margin. This margin is by design to allow for manufacturing variations in the reference voltage and the capacitors parasitics and temperature effects. The HIP6004 and HIP6005 voltage reference and DAC have an outstanding accuracy of  $\pm 1\%$  over temperature.

For applications where cost or volume is especially sensitive, and the  $\pm 5\%$  regulation number is not critical over all worst-case situations, the number of output capacitors may be reduced. Figures 10 and 11 show the HIP6004EVAL3 0A-14A transient response with only five output capacitors. These oscillograms show that the

converter still meets  $\pm 5\%$  regulation with a 2.8V output, but with less margin than with all nine output capacitors. At lower output voltages, such as 2.0V, the converter would not meet the regulation requirement.

Figure 12 shows the HIP6005EVAL3 transient response to a 0.2A-14A transient with only five output capacitors. Its response also meets the regulation requirements but with little margin. It is very likely that, with manufacturer variations, the converter will exceed the regulation window in response to this large of a load transient.

Changing the output filter of the converter affects the control loop characteristics in general. Reducing the number of output capacitors from nine to five pushes the L-C break frequency of the output filter out slightly and increases the 0dB crossover frequency. It also reduces the amount phase margin slightly, but there is still adequate phase margin with five output capacitors.

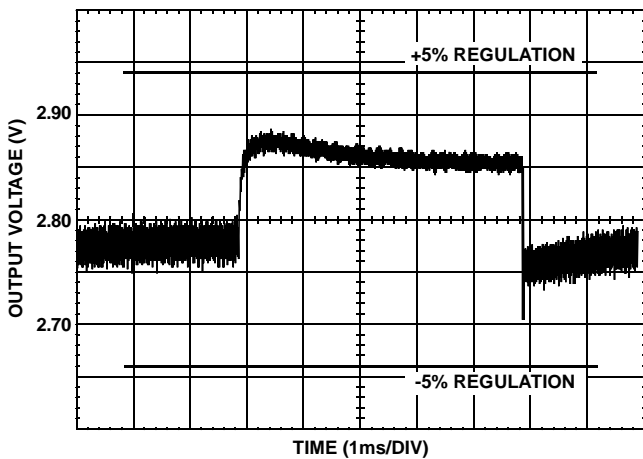

FIGURE 10. HIP6004EVAL3 TRANSIENT RESPONSE WITH C20-23 REMOVED

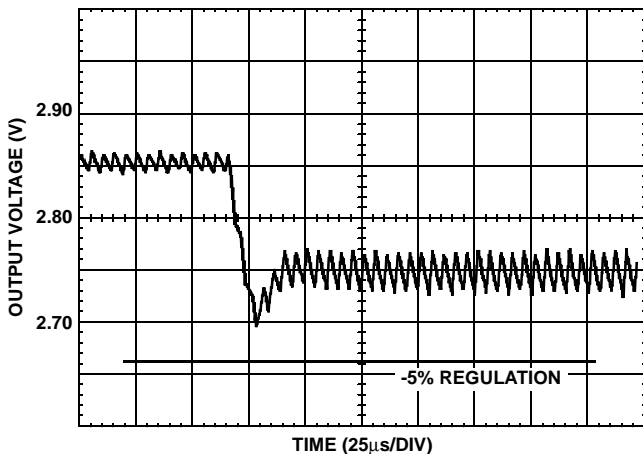

FIGURE 11. EXPANDED VIEW OF LEADING EDGE OF 0A TO 14A TRANSIENT SHOWN IN FIGURE 10

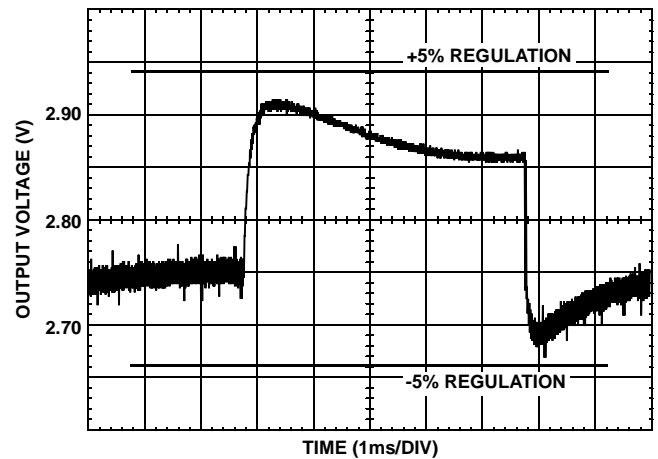

FIGURE 12. HIP6004EVAL5 TRANSIENT RESPONSE WITH C20-23 REMOVED

Reducing the number of output capacitors is possible but should be examined from a system standpoint. If the converter regulation requirement is firm at  $\pm 5\%$ , and the microprocessor core voltage can approach 2V, and the transient requirements approach 12A-14A steps, than the unmodified reference design (with nine output capacitors) should be employed. If one or more of these requirements is relaxed, than the number of capacitors may be reduced with satisfactory results.

### Transient Testing with Intel Test Tool

When testing the transient response of the HIP6004/5EVAL3 with an Intel-supplied test tool, some care must be taken for proper results. Jumpers JP0-4 must be installed on the evaluation board for proper operation of the converter. This is because the test tool uses CMOS output drivers on the VID signals, which are incompatible with the analog nature of VID0-4 on the HIP6004 and HIP6005. This is only an issue with the test tool and not any known microprocessor architecture. Grounding the five VID signals programs the converter output voltage to 2.05V and allows transient testing at this voltage. As shown in this application note, transient testing at this voltage level provides validation of the reference designs.

There is an additional jumper on the evaluation boards. JP5 is normally installed and **must** be removed if the Intel test tool is installed and the converter input source exceeds 5.5V. The Intel test tool uses Vcc5 for its bias source and JP5 connects IN of the evaluation board to Vcc5. If the evaluation board IN voltage is 5V, than JP5 can remain installed. If IN is 12V, than JP5 must be removed and an external 5V must be applied to Vcc5. See the schematics in the appendix for more details.

### **Conclusion**

The HIP6004EVAL3 and HIP6005EVAL3 are reference designs suitable for a DC-DC converter solution for the Pentium Pro and other high-performance microprocessors.

### **References**

For Intersil documents available on the web, see <http://www.intersil.com/>

- [1] *Pentium-Pro Processor Power Distribution Guidelines*, Intel Application Note AP-523, November, 1995.
- [2] *HIP6004 Data Sheet*, Intersil Corporation, Doc. No. FN4275.
- [3] *HIP6005 Data Sheet*, Intersil Corporation, Doc. No. FN4276.
- [4] *AN9668 Application Note*, Intersil Corporation, "An Embedded Pentium Pro Power Supply Using the HIP6002 PWM Controller (HIP6002EVAL1)", Doc. No. AN9668.

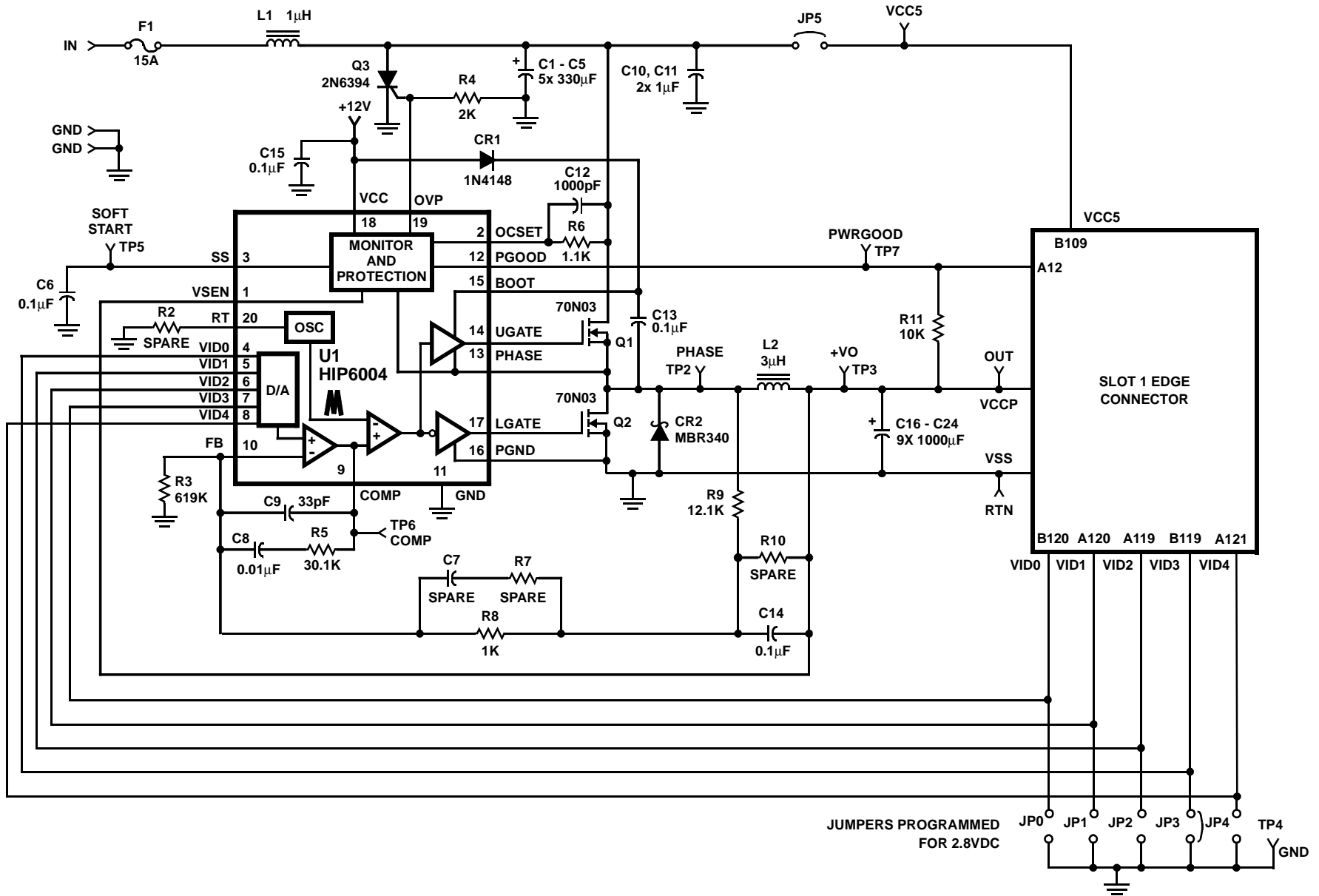

HIP6004EVAL3 SCHEMATIC

## Application Note 9706

### Bill of Materials for HIP6004EVAL3

PART NUMBER	DESCRIPTION	PACKAGE	QTY	REF	VENDOR
25MV330GX	330μF, 25V Aluminum Capacitor	Radial 8 x 20	5	C1 - C5	Sanyo
6MV1000GX	1000μF, 6.3V Aluminum Capacitor	Radial 8 x 20	9	C16 - C24	Sanyo
1206YZ105MAT1A	1.0μF, 16V, X7S Ceramic Capacitor	1206	3	C10, C11, C15	AVX
1000pF Ceramic	1nF, X7R Ceramic Capacitor	0805	1	C12	Various
0.1μF Ceramic	0.1μF, 25 V X7R Ceramic Capacitor	0805	3	C6, C13, C14	AVX/Panasonic
0.01μF Ceramic	0.01μF, X7R Ceramic Capacitor	0805	1	C8	Various
33pF Ceramic	33pF, X7R Ceramic Capacitor	0805	1	C9	Various
Spare	Spare Ceramic Capacitor	0805		C7	
1N4148	Rectifier 75V	DO35	1	CR1	Various
MBR340	3A, 40V, Schottky	Axial	1	CR2	Motorola
CTX09-13313-X1 PO343	5.3μH, 12A Inductor T50-52B core, 10 turns of 16 AWG wire	Wound Toroid	1	L2	Coiltronics Pulse
CTX09-13256-X1 PO342	1.2μH, 8A Inductor T50-52 core, 6 turns of 18 AWG wire	Wound Toroid	1	L1	Coiltronics Pulse
RFP70N03	10mΩ, 30V MOSFET	TO220	2	Q1, Q2	Intersil
2N6394	12A, 50V SCR	TO220	1	Q3	Motorola
HIP6004	Synchronous Rectified Buck Controller	SOIC-20	1	U1	Intersil
10kΩ	10kΩ, 5% 0.1W, Resistor	0805	1	R11	Various
Spare	Spare 0.1W, Resistor	0805		R2, R7, R10	
30.1kΩ	30.1kΩ, 5%, 0.1W, Resistor	0805	1	R5	Various
2kΩ	2kΩ, 5% 0.1W, Resistor	0805	1	R4	Various
619kΩ	619kΩ, 1% 0.1W, Resistor	0805	1	R3	Various
1kΩ	1kΩ, 5% 0.1W, Resistor	0805	1	R8	Various
1.1kΩ	1.1kΩ, 1% 0.1W, Resistor	0805	1	R6	Various
12.1kΩ	12.1kΩ, 1% 0.1W, Resistor	0805	1	R9	Various
145251-1 71796-0001	Slot 1 Edge Connector		1		AMP Molex
314015	15A Fuse	3AG	1	F1	Littelfuse
102071	Fuse Holder for 3AG Fuses	3AG	2		Littelfuse
576802B00000	TO-220 Clip-on Heatsink		2		AAVID
1514-2	Terminal Post		10	IN, 12V, GND, OUT, RTN, VCC5	Keystone
1314353-00	Scope Probe Test Point		1	TP3	Tektronics
SPCJ-123-01	Test Point		5	TP2, TP4 - TP7	Jolo



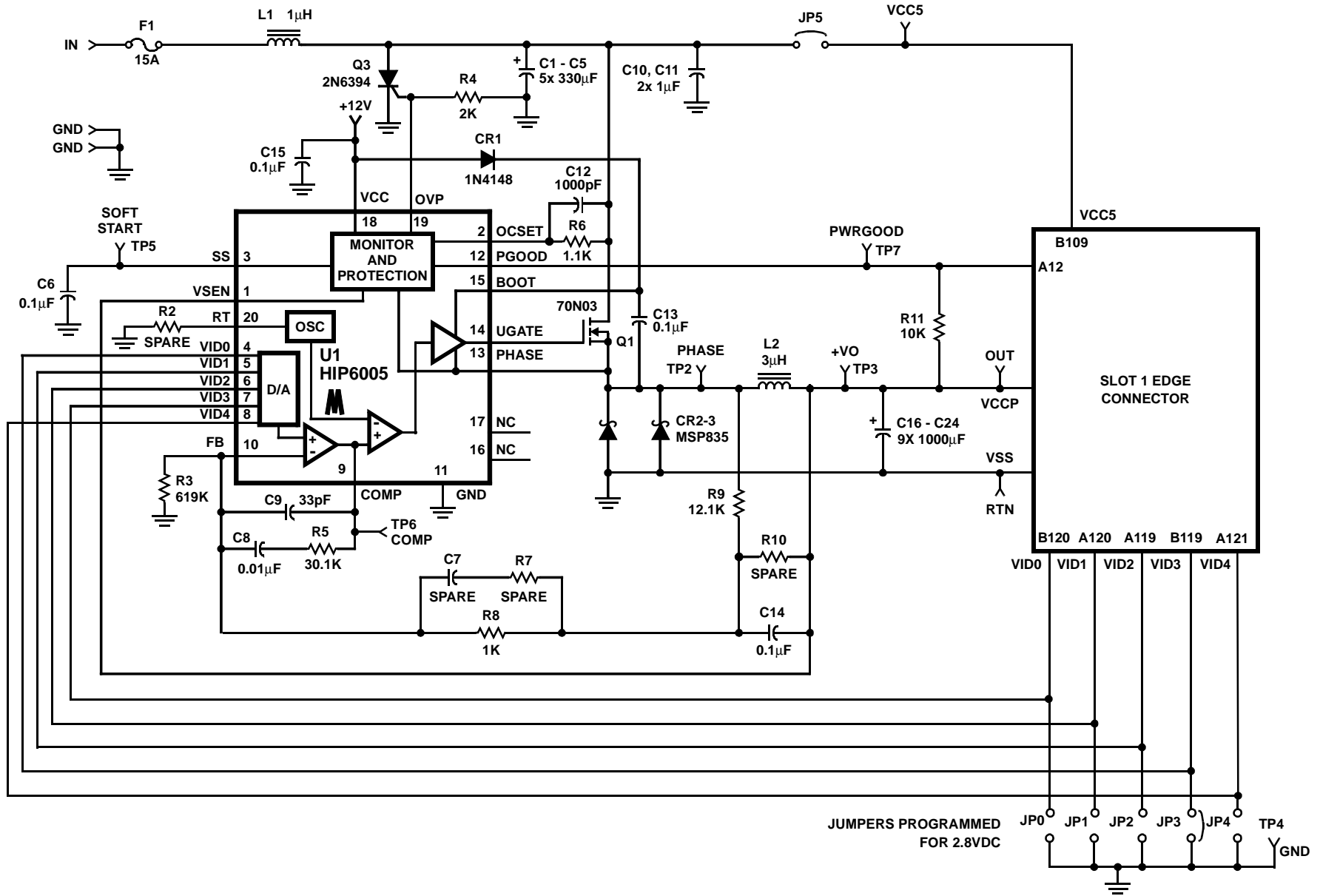

HIP6005EVAL3 SCHEMATIC

**Bill of Materials for HIP6005EVAL3**

PART NUMBER	DESCRIPTION	PACKAGE	QTY	REF	VENDOR
25MV330GX	330 $\mu$ F, 25V Aluminum Capacitor	Radial 8x20	5	C1 - C5	Sanyo
6MV1000GX	1000 $\mu$ F, 6.3V Aluminum Capacitor	Radial 8x20	9	C16 - C24	Sanyo
1206YZ105MAT1A	1.0 $\mu$ F, 16V, X7S Ceramic Capacitor	1206	3	C10, C11, C15	AVX
1000pF Ceramic	1nF, X7R Ceramic Capacitor	0805	1	C12	Various
0.1 $\mu$ F Ceramic	0.1 $\mu$ F, 25 V X7R Ceramic Capacitor	0805	3	C6, C13, C14	AVX/Panasonic
0.01 $\mu$ F Ceramic	0.01 $\mu$ F, X7R Ceramic Capacitor	0805	1	C8	Various
33pF Ceramic	33pF, X7R Ceramic Capacitor	0805	1	C9	Various
Spare	Spare Ceramic Capacitor	0805		C7	
1N4148	Rectifier 75V	DO35	1	CR1	Various
MSP835	8A, 35V, Schottky	Axial	2	CR2-3	Microsemi
CTX09-13337-X1 PO345	7 $\mu$ H, 12A Inductor T60-52 core, 14 turns of 17 AWG wire	Wound Toroid	1	L2	Coiltronics Pulse
CTX09-13256-X1 PO342	1.2 $\mu$ H, 8A Inductor T50-52 core, 6 turns of 18 AWG wire	Wound Toroid	1	L1	Coiltronics Pulse
RFP70N03	10m $\Omega$ , 30V MOSFET	TO220	1	Q1	Intersil
2N6394	12A, 50V SCR	TO220	1	Q3	Motorola
HIP6005	Buck PWM Controller	SOIC-20	1	U1	Intersil
10k $\Omega$	10k $\Omega$ , 5% 0.1W, Resistor	0805	1	R11	Various
Spare	Spare 0.1W, Resistor	0805		R2, R7, R10	
30.1k $\Omega$	30.1k $\Omega$ , 5%, 0.1W, Resistor	0805	1	R5	Various
2k $\Omega$	2k $\Omega$ , 5% 0.1W, Resistor	0805	1	R4	Various
619k $\Omega$	619k $\Omega$ , 1% 0.1W, Resistor	0805	1	R3	Various
1k $\Omega$	1k $\Omega$ , 5% 0.1W, Resistor	0805	1	R8	Various
1.1k $\Omega$	1.1k $\Omega$ , 1% 0.1W, Resistor	0805	1	R6	Various
12.1k $\Omega$	12.1k $\Omega$ , 1% 0.1W, Resistor	0805	1	R9	Various
145251-1 71796-0001	Slot 1 Edge Connector		1		AMP Molex
314015	15A Fuse	3AG	1	F1	Littelfuse
102071	Fuse Holder for 3AG Fuses	3AG	2		Littelfuse
576802B00000	TO-220 Clip-on Heatsink		2		AAVID
1514-2	Terminal Post		10	IN, 12V, GND, OUT, RTN, VCC5	Keystone
1314353-00	Scope Probe Test Point		1	TP3	Tektronics
SPCJ-123-01	Test Point		5	TP2, TP4 - TP7	Jolo

Board Description

SILK SCREEN

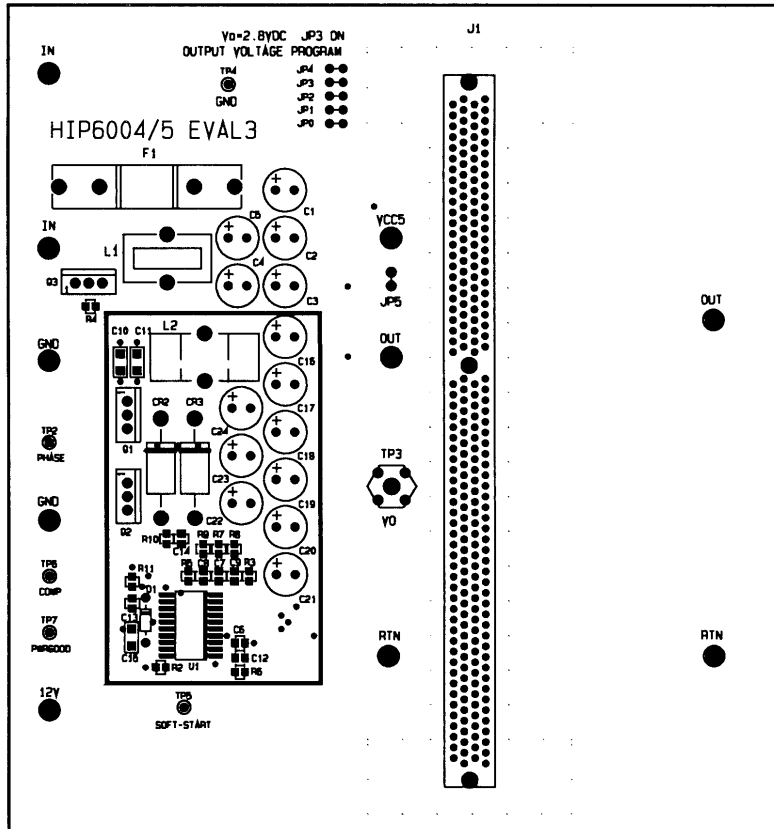

COMPONENT SIDE

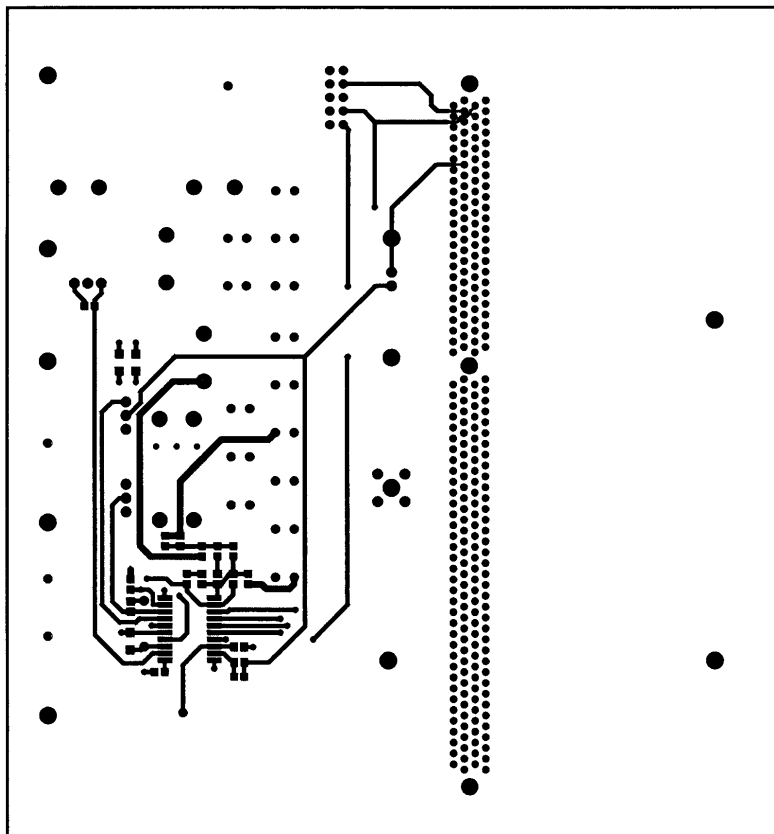

Board Description (Continued)

GND LAYER

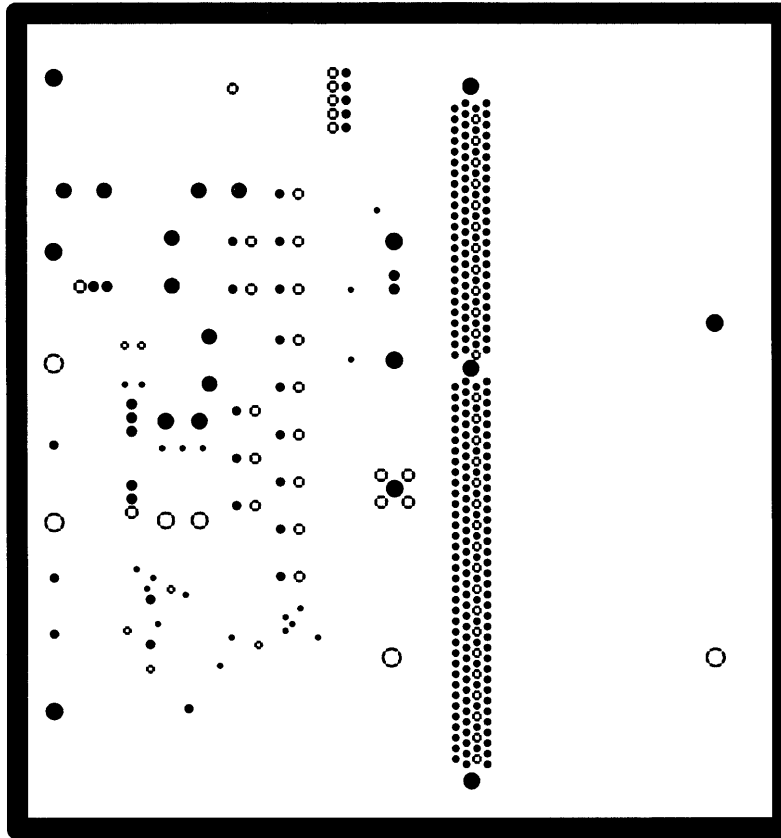

INTERNAL ONE

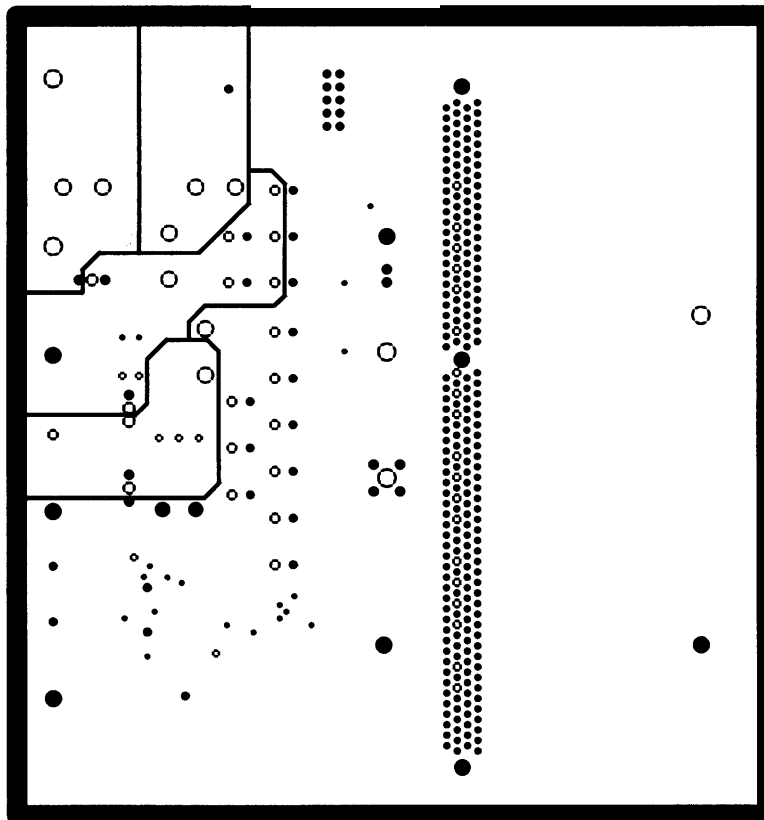

**Board Description** (Continued)

SOLDER SIDE

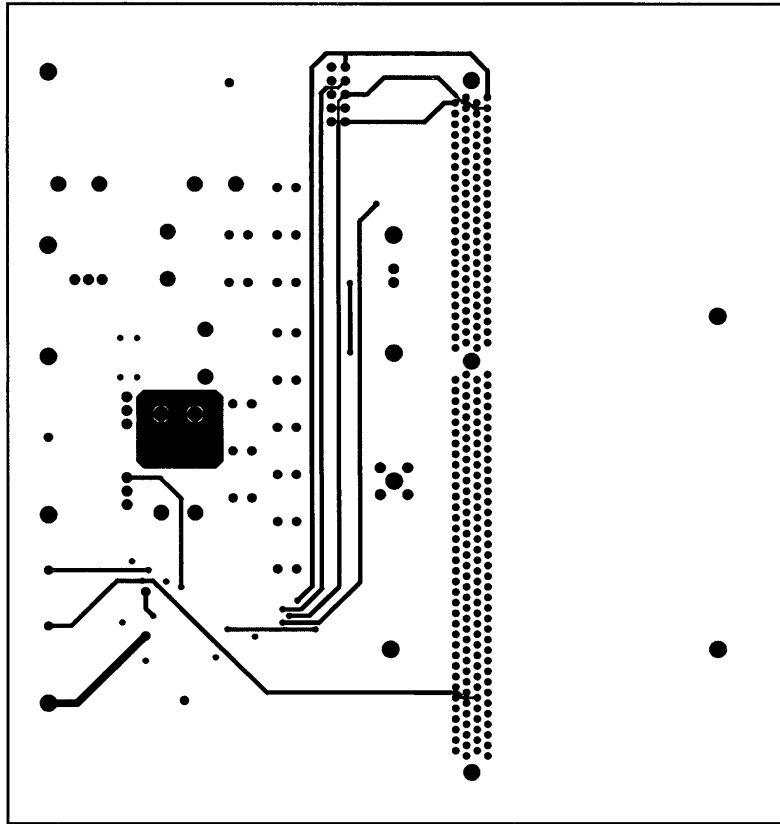

All Intersil U.S. products are manufactured, assembled and tested utilizing ISO9000 quality systems.

Intersil Corporation's quality certifications can be viewed at [www.intersil.com/design/quality](http://www.intersil.com/design/quality)

*Intersil products are sold by description only. Intersil Corporation reserves the right to make changes in circuit design, software and/or specifications at any time without notice. Accordingly, the reader is cautioned to verify that data sheets are current before placing orders. Information furnished by Intersil is believed to be accurate and reliable. However, no responsibility is assumed by Intersil or its subsidiaries for its use; nor for any infringements of patents or other rights of third parties which may result from its use. No license is granted by implication or otherwise under any patent or patent rights of Intersil or its subsidiaries.*

For information regarding Intersil Corporation and its products, see [www.intersil.com](http://www.intersil.com)

# AMEYA360

## Components Supply Platform

Authorized Distribution Brand :



Website :

Welcome to visit [www.ameya360.com](http://www.ameya360.com)

Contact Us :

➤ Address :

401 Building No.5, JiuGe Business Center, Lane 2301, Yishan Rd  
Minhang District, Shanghai , China

➤ Sales :

Direct +86 (21) 6401-6692

Email [amall@ameya360.com](mailto:amall@ameya360.com)

QQ 800077892

Skype [ameyasales1](#) [ameyasales2](#)

➤ Customer Service :

Email [service@ameya360.com](mailto:service@ameya360.com)

➤ Partnership :

Tel +86 (21) 64016692-8333

Email [mkt@ameya360.com](mailto:mkt@ameya360.com)