

**NOTE**



All numerical values are in metric units [with U.S. customary units in brackets]. Dimensions are in millimeters [and inches]. Unless otherwise specified, dimensions have a tolerance of  $\pm 0.13$  [ $\pm 0.005$ ] and angles have a tolerance of  $\pm 2^\circ$ . Figures and illustrations are for identification only and are not drawn to scale.

## 1. INTRODUCTION

This specification covers the requirements for application of LED Star Board Holder for use in direct lighting applications (such as office, automotive, communications, and architectural). The star board holder is designed to house and provide electrical interconnection and thermal solution for a high-power LED star printed circuit (pc) board light source. The star board holder consists of a heat sink, locking ring, and contact carrier assembly. A thermally-conductive pad (available separately) or thermal grease must be used for assembly. A diffuser lens is available separately as an option. Snap-on adapters for commercial fiber optic lenses and light pipes are also available separately. Soldering or thermally-conductive adhesive is not required for assembly.

The star board holder is capable of two-contact loading for single-color LEDs and three- or four-contact loading for full-color (RGB) LEDs (common anode or common cathode). The contact carrier assembly and heat sink are marked with A, B, C, and D to reference the polarity of the LED to ensure proper orientation in the lighting fixture. These star board holders are designed to be used with an Underwriters Laboratories Inc. (UL) Class 2 power supply.

When corresponding with TE Connectivity Personnel, use the terminology provided in this specification to facilitate your inquiries for information. Basic terms and features of this product are provided in Figure 1.

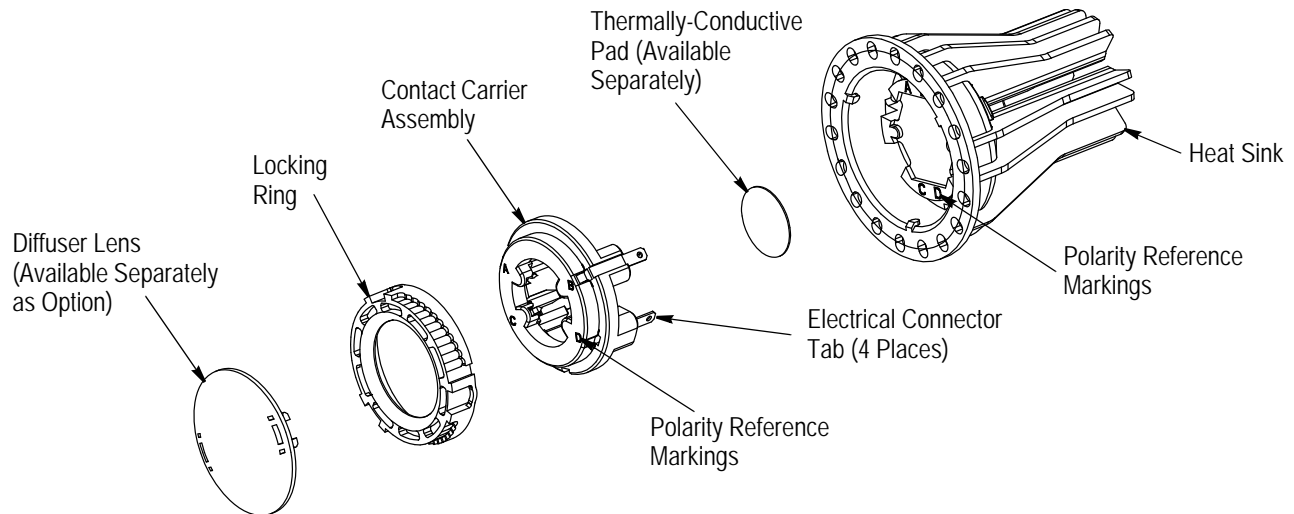

Figure 1

## 2. REFERENCE MATERIAL

### 2.1. Revision Summary

- Updated document to corporate requirements
- New logo

### 2.2. Customer Assistance

Reference Part Number 2008675 and Product Code L012 are representative of LED Star Board Holder. Use of these numbers will identify the product line and expedite your inquiries through a service network established to help you obtain product and tooling information. Such information can be obtained through a TE Representative or, after purchase, by calling PRODUCT INFORMATION at the number at the bottom of this page.

## 2.3. Drawings

Customer Drawings for product part numbers are available from the service network. If there is a conflict between the information contained in the Customer Drawings and this specification or with any other technical documentation supplied, call PRODUCT INFORMATION at the number at the bottom of page 1.

## 2.4. Specifications

Product Specification 108-2350 provides product performance and test information.

## 2.5. Instructional Material

Instruction Sheets (408-series) provide product assembly instructions or tool setup and operation procedures. Documents available which pertain to this product are:

408-10280      LED Star Board Holder Kit 2008675-1

## 3. REQUIREMENTS

### 3.1. Material

The contact carrier assembly and locking ring are made of polybutylene terephthalate (PBT). The contacts are made of copper alloy plated with tin. The heat sink is made of cast aluminum. The available lens is made of polycarbonate.

### 3.2. Safety

Do not stack product shipping containers so high that the containers buckle or deform.

### 3.3. Limitations

The star board holder is designed to operate in a temperature range of -40° to 85°C [-40° to 185°F].

### 3.4. Storage

#### A. Shelf Life

The star board holder should remain in the shipping containers until ready for use to prevent deformation to the contacts. The assemblies should be used on a first in, first out basis to avoid storage contamination that could adversely affect performance.

#### B. Chemical Exposure

Do not store the star board holder near any chemical listed below as they may cause stress corrosion cracking in the contacts.

Alkalies	Ammonia	Citrates	Phosphates	Citrates	Sulfur Compounds
Amines	Carbonates	Nitrites	Sulfur	Nitrites	Tartrates

### 3.5. Thermal Performance

The thermal performance of the overall system is paramount to the life of the LED. The star board holder supports 1 to 4 watts of input to the LED without using forced air cooling or additional heat sink. IT IS IMPORTANT that the thermal management is adequate for the specific LED and lighting fixture used. LEDs with higher wattage rating can be used if forced air cooling or additional heat sink is employed.

### 3.6. Customer Supplied Components

#### A. LED

The star board holder is compatible with hexagonal "star board" high-power LEDs measuring 19.9 mm [.783 in.] across the hexagonal flats and having a thickness of 1 to 2.5 mm [.040 to .01 in.]. A sample reference star board pattern is given in Figure 2.

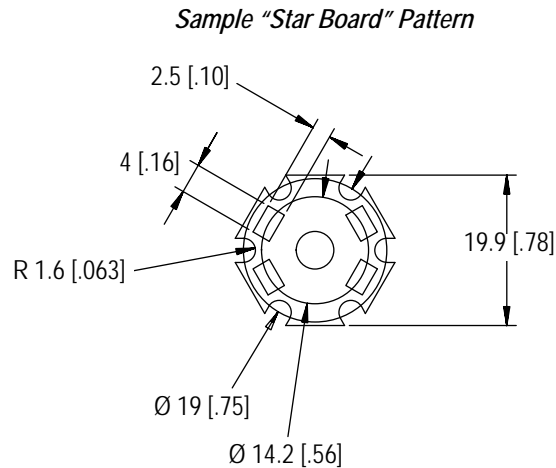

*Figure 2*

### B. Connections

The electrical connector tabs of the star board holder accept Ultra-Fast Series 110 fully-insulated FASTON\* cable assemblies.

### C. Thermally-Conductive Pad or Thermal Grease

A thermally-conductive pad or thermal grease must be used for assembly.

### 3.7. Assembly

The star board holder must be assembled using the following requirements:

1. A thermally-conductive pad or thermal grease must be placed into the hexagonal inset of the heat sink.
2. The LED must be installed over the thermally-conductive pad or thermal grease. The polarity of the LED should be oriented with the polarity reference markings of the heat sink.
3. The contact carrier assembly must be inserted into the heat sink with the polarity reference markings aligned with polarity reference markings of the heat sink (A with A, B with B, C with C, and D with D).
4. The locking ring must be inserted into the heat sink and rotated using a long-nosed pliers or large snap ring tool with right-angle tips so that it secures the contact carrier assembly.
5. If used, the diffuser lens and other optional components must be installed onto the locking ring.
6. The cable assemblies must be connected to the electrical connector tabs.

Refer to Figure 3.

*Assembly*

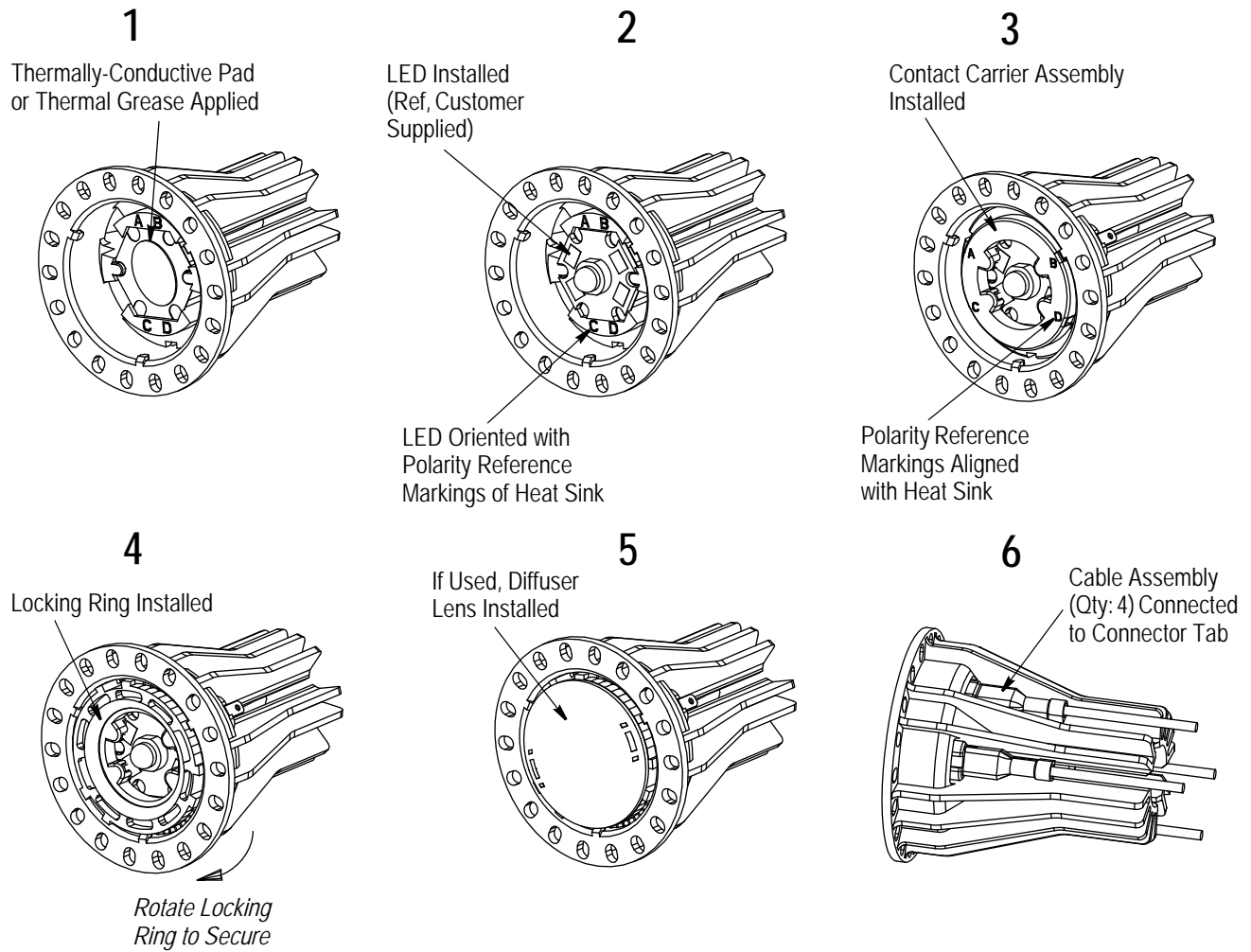

Figure 3

**3.8. Replacement and Repair**

The star board holder is not repairable. Damaged or defective components **MUST NOT** be used.

**4. QUALIFICATION**

No qualifying support for LED Star Board Holder was defined at the time of publication of this document.

**5. TOOLING**

A long-nosed pliers or a large snap ring tool with right-angle tips to install the locking ring.

## 6. VISUAL AID

The illustration below shows a typical application of this product. This illustration should be used by production personnel to ensure a correctly applied product. Applications which DO NOT appear correct should be inspected using the information in the preceding pages of this specification and in the instructional material shipped with the product or tooling.

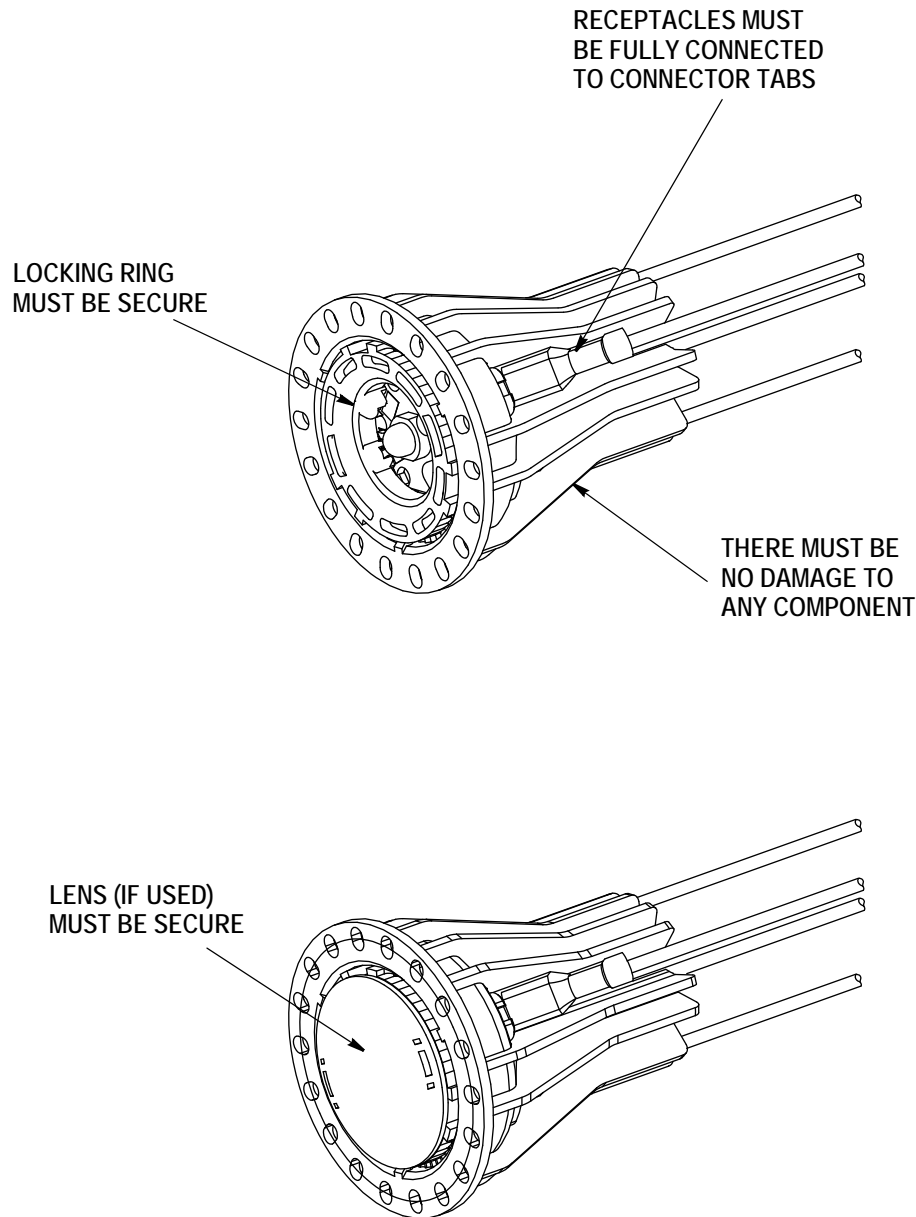

**FIGURE 4. VISUAL AID**

# AMEYA360

## Components Supply Platform

Authorized Distribution Brand :



Website :

Welcome to visit [www.ameya360.com](http://www.ameya360.com)

Contact Us :

➤ Address :

401 Building No.5, JiuGe Business Center, Lane 2301, Yishan Rd  
Minhang District, Shanghai , China

➤ Sales :

Direct +86 (21) 6401-6692

Email [amall@ameya360.com](mailto:amall@ameya360.com)

QQ 800077892

Skype [ameyasales1](#) [ameyasales2](#)

➤ Customer Service :

Email [service@ameya360.com](mailto:service@ameya360.com)

➤ Partnership :

Tel +86 (21) 64016692-8333

Email [mkt@ameya360.com](mailto:mkt@ameya360.com)