

Data Sheet



Description

This family of SMT LEDs is packaged in the industry standard PLCC-2 package. These SMT LEDs have high reliability performance and are designed to work under a wide range of environmental conditions. This high reliability feature makes them ideally suited to be used under harsh interior signs application conditions. This SMT LED package come with a black surface and tinted which is specially designed for signs application to minimize ambient reflection to improve contrast.

To facilitate easy pick & place assembly, the LEDs are packed in EIA-compliant tape and reel. Every reel will be shipped in single intensity and color bin, except red color, to provide close uniformity.

These LEDs are compatible with IR solder reflow process. Due to the high reliability feature of these products, they can also be mounted using through-the-wave soldering process.

The super wide viewing angle at 120° makes these LEDs ideally suited for panel, push button, or general back-lighting in automotive interior, office equipment, industrial equipment, and home appliances. The flat top emitting surface makes it easy for these LEDs to mate with light pipes. With the built-in reflector pushing up the intensity of the light output, these LEDs are also suitable to be used as LED pixels in interior electronic signs.

Features

- Industry standard PLCC-2 package
- High reliability LED package
- High brightness using AlInGaP and InGaN dice technologies
- Available in full selection of colors
- Super wide viewing angle at 120°
- Available in 8 mm carrier tape on 7 inch reel (2000 pieces)
- Compatible with both IR and TTW soldering process
- Black Surface Tinted
- JEDEC MSL 2a

Applications

- Electronic signs and signals
- Interior full color sign
- Variable message sign

CAUTION: HSM and HSMN-A1xx-xxxxx LEDs are Class 2 ESD sensitive. Please observe appropriate precautions during handling and processing. Refer to Avago Technologies Application Note AN-1142 for additional details.

Package Dimensions

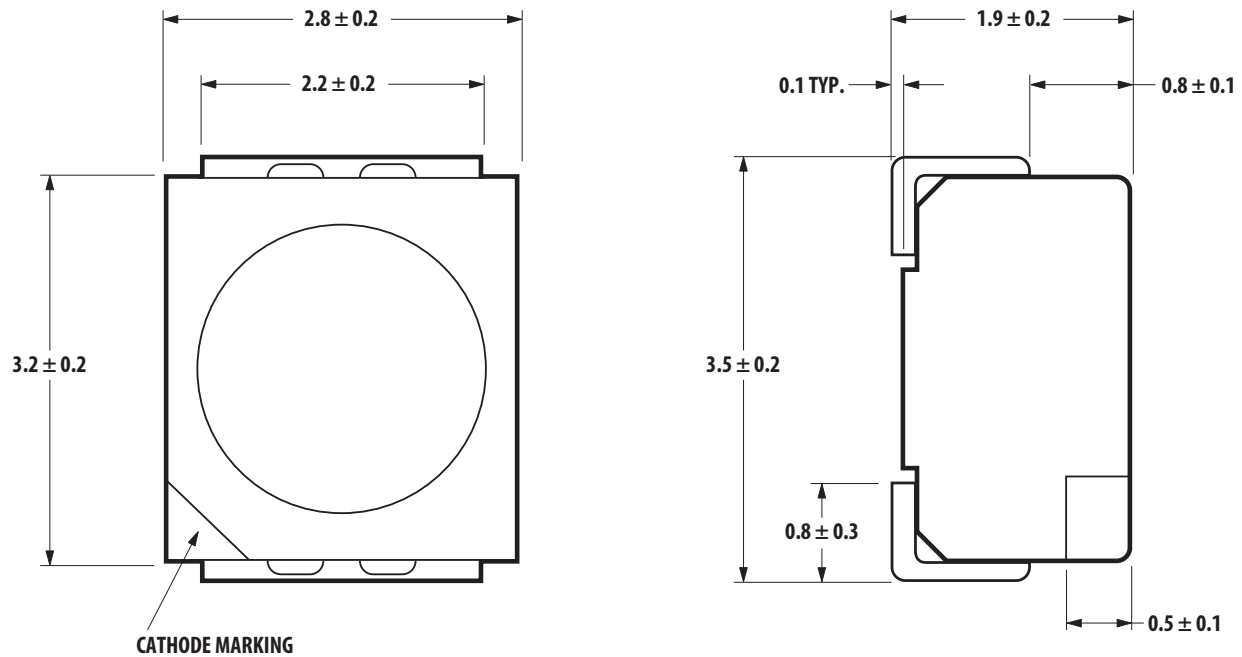

Notes: All dimensions in mm

Device Selection Guide

Color	Part Number	Min I_v @ 20mA (mcd)	Typical I_v @ 20mA (mcd)
Red	HSMC-A160-Q00J1	63.0	100.0
	HSMC-A161-S00J1	160.0	220.0
Yellow /Amber	HSMA-A160-Q00J1	63.0	100.0
	HSMA-A161-S00J1	160.0	220.0
Green	HSMM-A160-S00J1	160.0	350.0
Blue	HSMN-A161-N00J1	25.0	50.0
	HSMN-A160-P00J1	40.0	70.0

Notes:

- The luminous intensity I_v is measured at the mechanical axis of the lamp package.
The actual peak of the spatial radiation pattern may not be aligned with this axis.
- I_v Tolerance = $\pm 12\%$

Absolute Maximum Ratings ($T_A = 25^\circ\text{C}$)

Parameters	HSMC/A	HSMV/Z	HSMM/N
DC Forward Current ^[1]	30 mA ^[3,4]	30 mA ^[3,4]	30 mA
Peak Forward Current ^[2]	100mA	100mA	100mA
Power Dissipation	63mW	72mW	114mW
Reverse Voltage	5	5	5
Junction Temperature	110°C	110°C	110°C
Operating Temperature	-55°C to +100°C	-55°C to +100°C	-55°C to +100°C
Storage Temperature	-55°C to +100°C	-55°C to +100°C	-55°C to +100°C

Notes:

1. Derate linearly as shown in figure 5.
2. Duty factor = 10%, Frequency = 1kHz.
3. Drive Current between 10mA and 30mA are recommended for best long term performance
4. Operation at current below 5mA is not recommended.

Optical Characteristic ($T_A = 25^\circ\text{C}$)

Color	Part Number	Dice Technology	Peak Wavelength λ_{PEAK} (nm) Typ.	Dominant Wave-length λ_D (nm) ^[1] Typ.	Viewing Angle $2\theta_{1/2}$ ^[2] (Degrees) Typ.	Luminous Efficacy η_V ^[3] (lm/W) Typ	Luminous Intensity/ Total Flux I_V (mcd)/ F_V (mlm) Typ.
Amber	HSMA-A161	AllnGaP	592	590	120	480	0.45
Amber	HSMU-A160	AllnGaP	594	592	120	500	0.45
Red	HSMC-A161	AllnGaP	635	626	120	150	0.45
Red	HSMZ-A160	AllnGaP	639	630	120	155	0.45
Green	HSMM-A16x	InGaN	523	525	120	500	0.45
Blue	HSMN-A16x	InGaN	468	470	120	75	0.45

Notes:

1. The dominant wavelength, λ_D , is derived from the CIE Chromaticity Diagram and represents the color of the device.
2. $\theta_{1/2}$ is the off-axis angle where the luminous intensity is 1/2 the peak intensity.
3. Radiant intensity, I_e in watts/steradian, may be calculated from the equation $I_e = I_V/\eta_V$, where I_V is the luminous intensity in candelas and η_V is the luminous efficacy in lumens/watt.

Electrical Characteristic ($T_A = 25^\circ\text{C}$)

Dice Technology	Forward Voltage V_F (Volts) @ $I_F = 20\text{mA}$		Reverse Voltage V_R @ $100\mu\text{A}$	Reverse Voltage V_R @ $10\mu\text{A}$	Thermal Resistance $R\theta_{JP}$ ($^\circ\text{C}/\text{W}$)
	Typ	Max	Min	Min	Typ
HSMC/A	1.9	2.4	5	-	280
HSMV/Z	2.2	2.6	5	-	280
HSMM/N	3.4	4.05	-	5	280

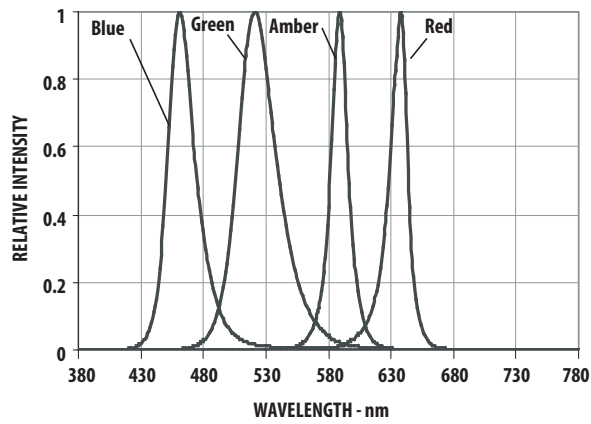

Figure 1. Relative Intensity vs. Wavelength

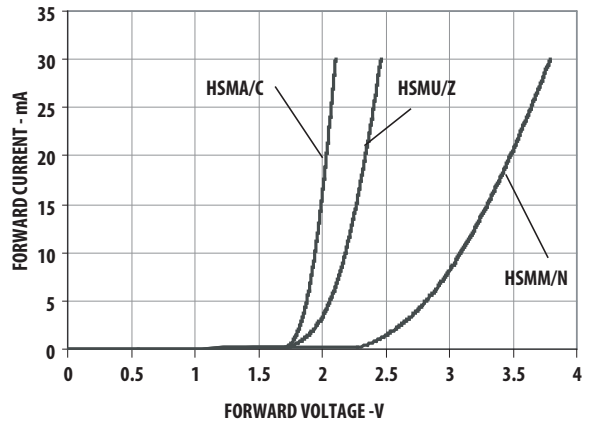

Figure 2. Forward Current vs. Forward Voltage

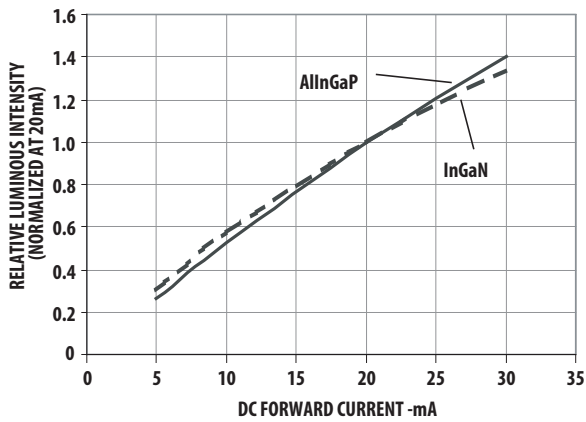

Figure 3. Relative Intensity vs. Forward Current

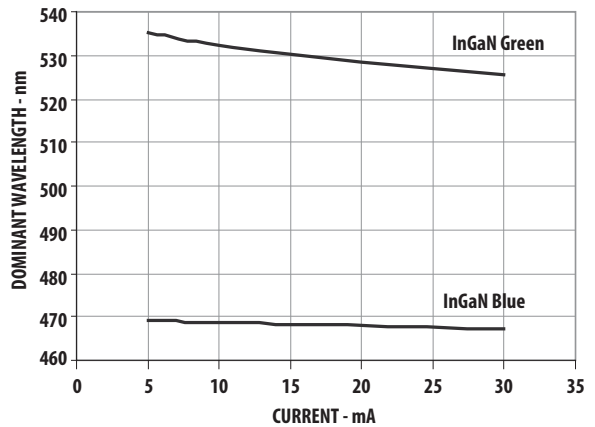

Figure 4. Dominant Wavelength vs. Forward Current InGaN

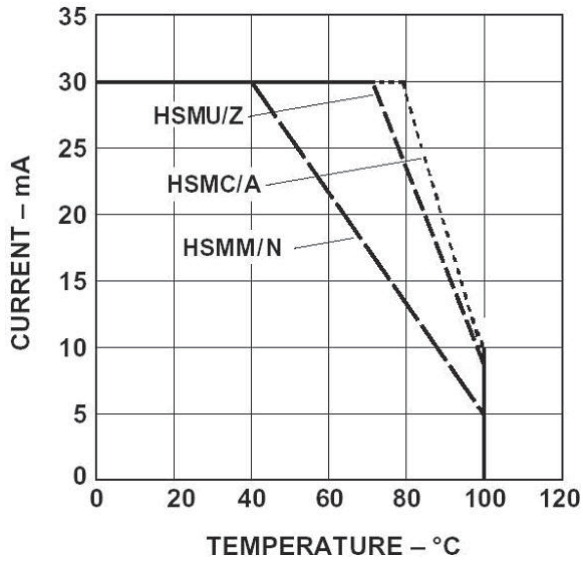

Figure 5. Maximum Forward Current Vs. Ambient Temperature. Derated Based on $T_{J\text{ MAX}} = 110^\circ\text{C}$, $R\theta_{JA} = 500^\circ\text{C/W}$

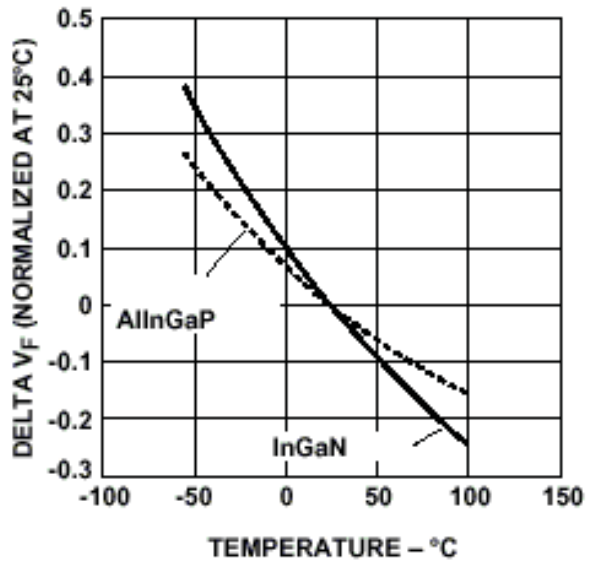

Figure 6. Forward Voltage Shift vs. Temperature

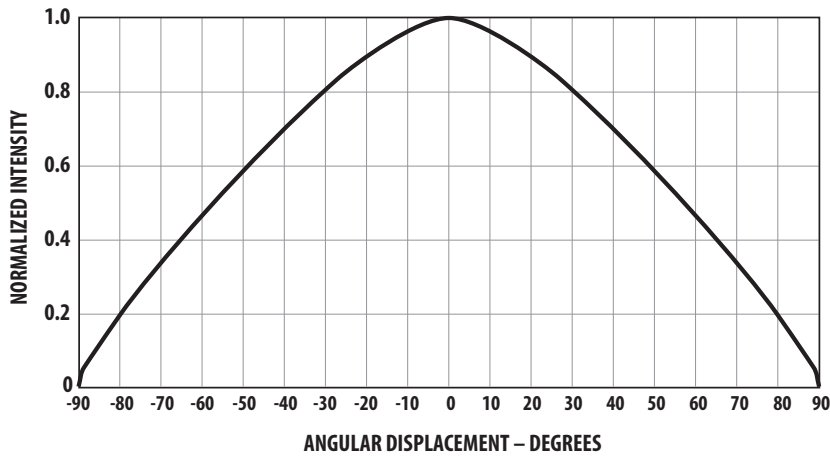

Figure 7. Radiation Pattern

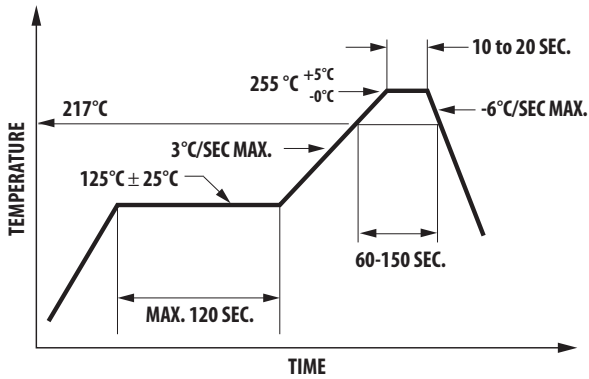

Figure 8. Recommended Pb-Free Reflow Soldering Profile

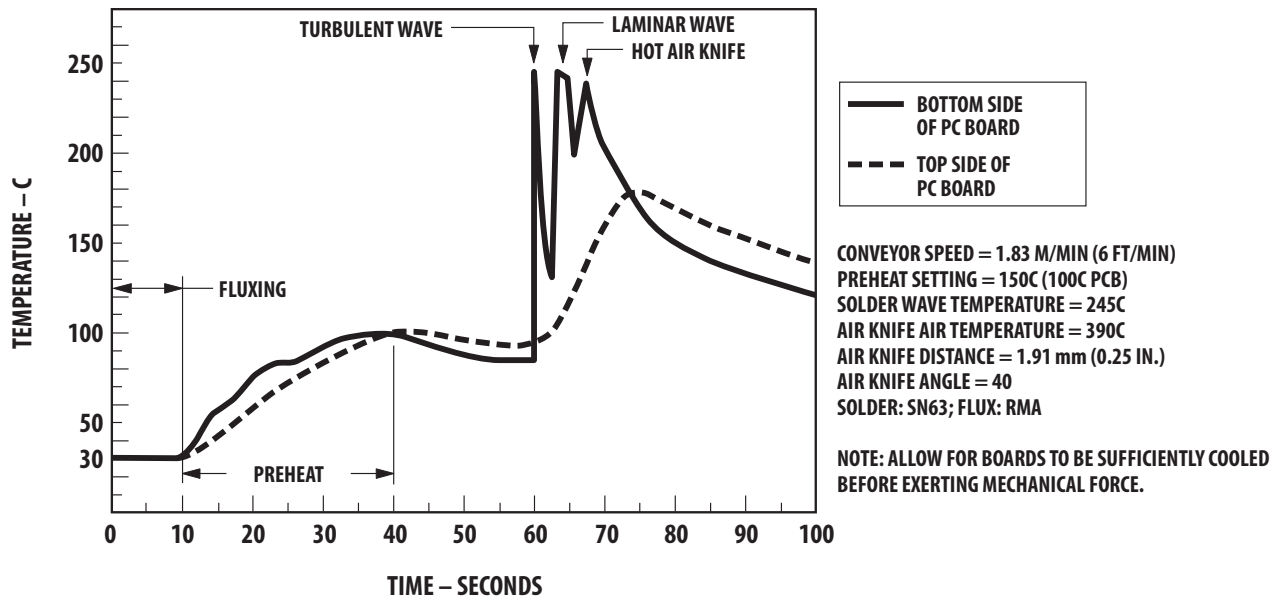

Figure 9. Recommended Wave Soldering Profile

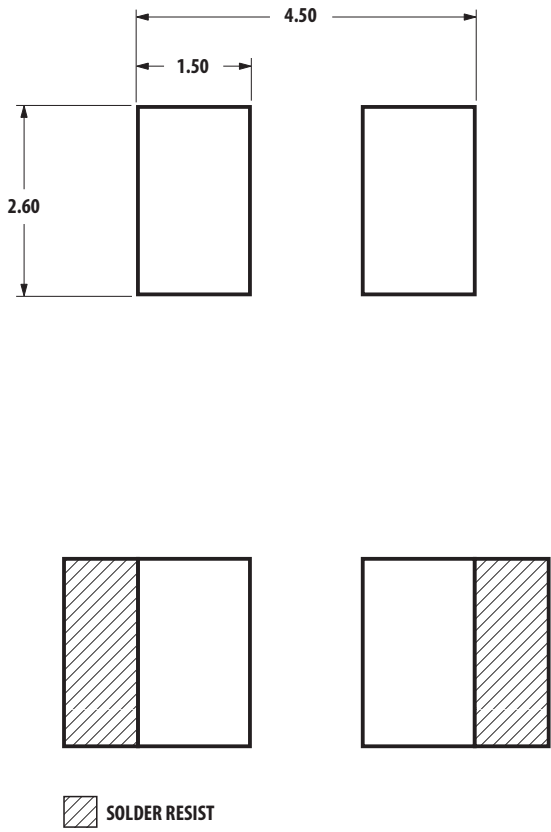

Figure 10. Recommended soldering pad pattern

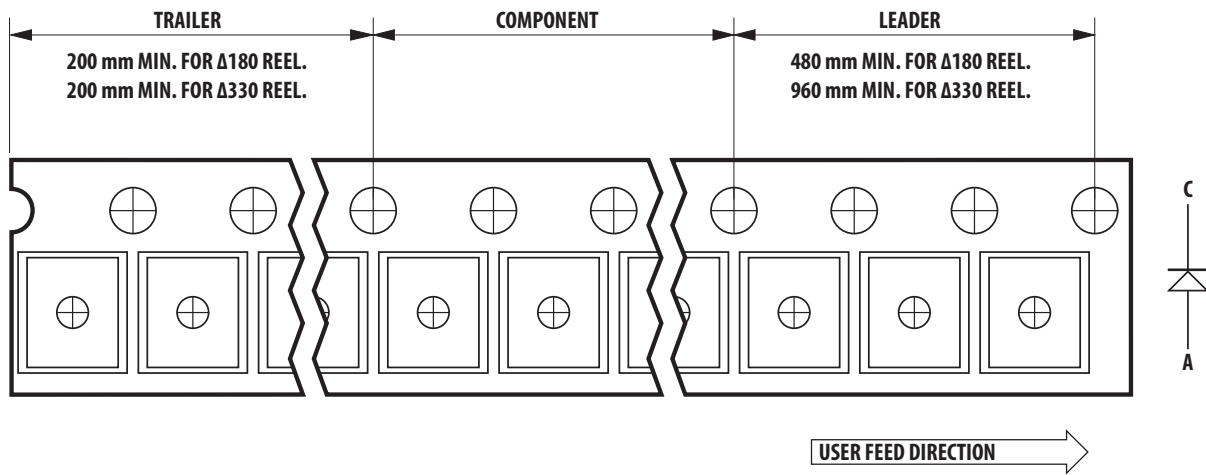

Figure 11. Tape leader and Trailer dimension

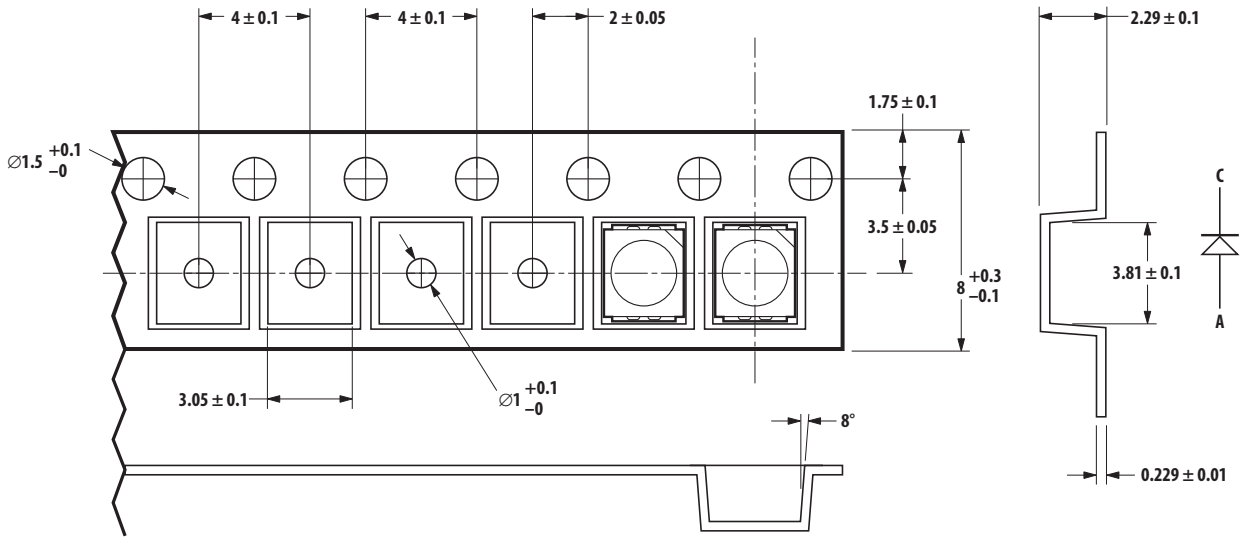

Figure 12. Tape dimensions

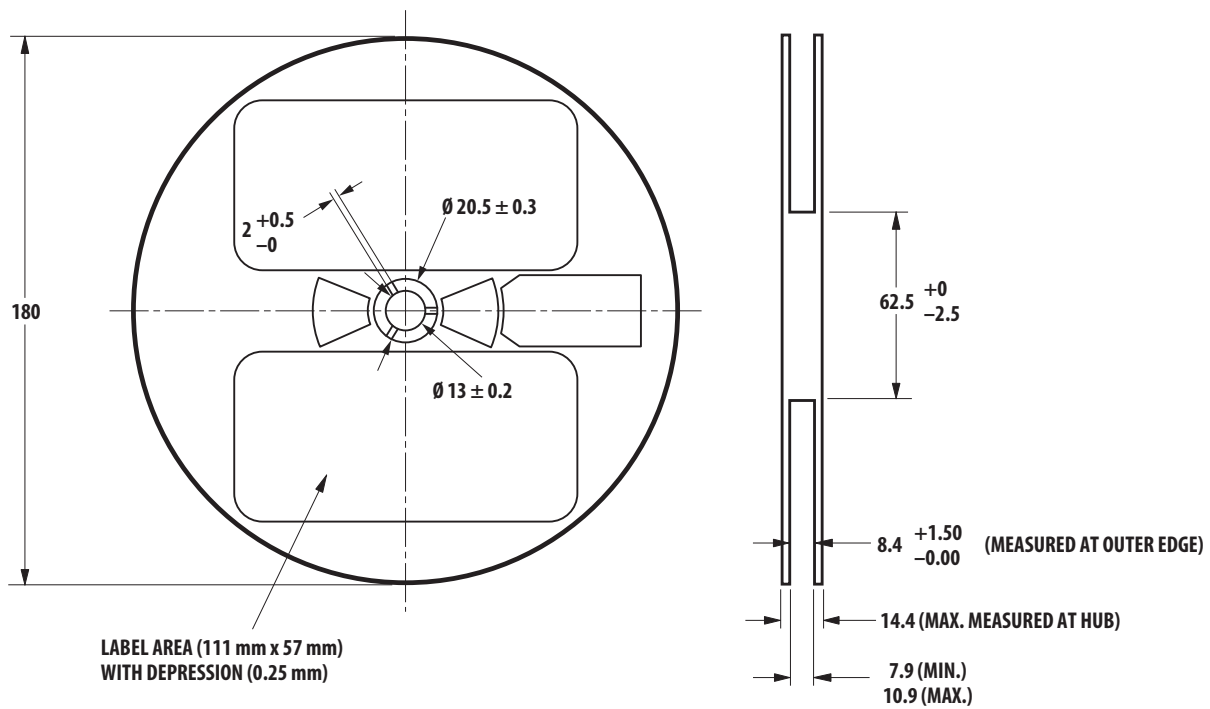

Figure 13. Reel dimensions

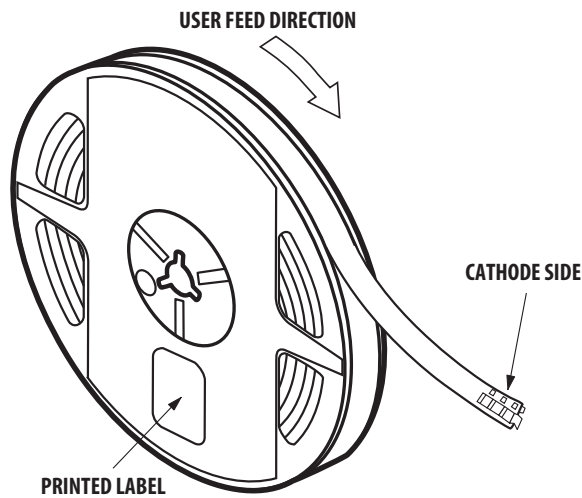

Figure 14. Reeling Orientation

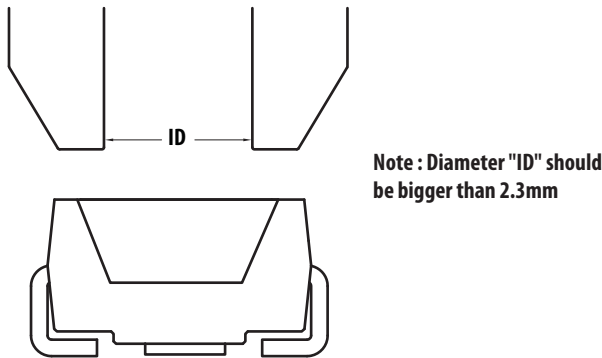

Figure 15. Recommended Pick and Place Nozzle Size

Moisture Sensitivity

This product is qualified as Moisture Sensitive Level 2a per J-STD-020. Precautions when handling this moisture sensitive product is important to ensure the reliability of the product. Do refer to Avago Application Note AN5305 Handling of Moisture Sensitive Surface Mount Devices for details.

A. Storage before use

- Unopen moisture barrier bag (MBB) can be stored at $<40^{\circ}\text{C}/90\%\text{RH}$ for 12 months. If the actual shelf life has exceeded 12 months and the HIC indicates that baking is not required, then it is safe to reflow the LEDs per the original MSL rating.
- It is not recommended to open the MBB prior to assembly (e.g. for IQC).

B. Control after opening the MBB

- The humidity indicator card (HIC) shall be read immediately upon opening of MBB.
- The LEDs must be kept at $<30^{\circ}\text{C} / 60\%\text{RH}$ at all time and all high temperature related process including soldering, curing or rework need to be completed within 672 hours.

C. Control for unfinished reel

- For any unused LEDs, they need to be stored in sealed MBB with desiccant or desiccator at $<5\%\text{RH}$.

D. Control of assembled boards

- If the PCB soldered with the LEDs is to be subjected to other high temperature processes, the PCB need to be stored in sealed MBB with desiccant or desiccator at $<5\%\text{RH}$ to ensure no LEDs have exceeded their floor life of 672 hours.

E. Baking is required if:

- "10%" is Not blue and "5%" HIC indicator turns pink.
- The LEDs are exposed to condition of $>30^{\circ}\text{C} / 60\%\text{RH}$ at any time.
- The LEDs floor life exceeded 672 hours.

Recommended baking condition: $60\pm 5^{\circ}\text{C}$ for 20 hours.

Intensity Bin Select (X5X6)

Individual reel will contain parts from 1 half bin only

X ₅	Min Iv Bin
X ₆	
0	Full Distribution
3	3 half bins starting from X ₅ 1
4	4 half bins starting from X ₅ 1
5	5 half bins starting from X ₅ 1
7	3 half bins starting from X ₅ 2
8	4 half bins starting from X ₅ 2
9	5 half bins starting from X ₅ 2

Intensity Bin Limits

Bin ID	Min (mcd)	Max (mcd)
J1	4.50	5.60
J2	5.60	7.20
K1	7.20	9.00
K2	9.00	11.20
L1	11.20	14.00
L2	14.00	18.00
M1	18.00	22.40
M2	22.40	28.50
N1	28.50	35.50
N2	35.50	45.00
P1	45.00	56.00
P2	56.00	71.50
Q1	71.50	90.00
Q2	90.00	112.50
R1	112.50	140.00
R2	140.00	180.00
S1	180.00	224.00
S2	224.00	285.00
T1	285.00	355.00
T2	355.00	450.00
U1	450.00	560.00
U2	560.00	715.00

Tolerance of each bin limit = ± 12%

Packaging Option (X₈X₉)

X ₈ X ₉	
J1	20mA test current, Top Mount, 7 inch Reel
J2	10mA test current, Top Mount, 7 inch Reel

Color Bin Select (X7)

Individual reel will contain parts from 1 full bin only

X ₇	
0	Full Distribution
Z	A and B only
Y	B and C only
W	C and D only
V	D and E only
U	E and F only
T	F and G only
S	G and H only
Q	A, B and C only
P	B, C and D only
N	C, D and E only
M	D, E and F only
L	E, F and G only
K	F, G and H only
1	A, B, C and D only
2	E, F G and H only

Color Bin Limits

Blue	Min (nm)	Max (nm)
A	460.0	465.0
B	465.0	470.0
C	470.0	475.0
D	475.0	480.0
Green	Min (nm)	Max (nm)
A	515.0	520.0
B	520.0	525.0
C	525.0	530.0
D	530.0	535.0
Amber/Yellow	Min (nm)	Max (nm)
A	582.0	584.5
B	584.5	587.0
C	587.0	589.5
D	589.5	592.0
E	592.0	594.5
F	594.5	597.0
Red	Min (nm)	Max (nm)
Full Distribution		

Tolerance of each bin limit = ±1nm

For product information and a complete list of distributors, please go to our web site: www.avagotech.com

Avago, Avago Technologies, and the A logo are trademarks of Avago Technologies in the United States and other countries.

Data subject to change. Copyright © 2005-2012 Avago Technologies. All rights reserved. Obsoletes AV01-0652EN

AV02-0764EN - May 24, 2012

AMEYA360

Components Supply Platform

Authorized Distribution Brand :



Website :

Welcome to visit www.ameya360.com

Contact Us :

➤ Address :

401 Building No.5, JiuGe Business Center, Lane 2301, Yishan Rd
Minhang District, Shanghai , China

➤ Sales :

Direct +86 (21) 6401-6692

Email amall@ameya360.com

QQ 800077892

Skype [ameyasales1](#) [ameyasales2](#)

➤ Customer Service :

Email service@ameya360.com

➤ Partnership :

Tel +86 (21) 64016692-8333

Email mkt@ameya360.com