

NS5S1153

USB 2.0 High Speed and Audio Switch with Negative Swing Capability

The NS5S1153 is a DPDT switch for combined true-ground audio and USB 2.0 high speed data applications. It allows portable systems to use a single port to pass either USB data or audio signals from an external headset; headset; the 2 channels being compliant to USB 2.0, USB 1.1 and USB 1.0.

The switch is capable of passing signals with negative voltages as low as 2 V below ground. The device features shunt resistors on the audio ports. These resistors are switched in when the audio channel is off and provide a safe path to ground for any charge that may build up on the audio lines. This reduces Pop & Click noise in the audio system. The NS5S1153 is also equipped with VBUS detection circuitry to immediately switch to USB mode in the event that a voltage is detected on VBUS.

The NS5S1153 is housed in a space saving, ultra low profile 1.4 x 1.8 x 0.5 mm 10 pin UQFN package.

Features

- 2:1 High Speed Switch
- USB 2.0, USB 1.1 & USB 1.0 Capable on all channels
- High Bandwidth of 820 MHz on D+/D-
- Capable of Passing Negative Swing Signals Down to -2 V on R/L Channel
- 1.8 V Compatible Control Pin & VBUS Detection Circuitry for Automatic Switching
- Audio Channel Shunt Resistors for Pop & Click Noise Reduction
- Ultra-Low THD in Audio Mode: 0.01% into 16 Ω Load
- 5.25 V Tolerant Common Pins
- This is a Pb-Free Device

Typical Applications

- Micro or Mini USB Applications
- Shared High Speed Data or Audio on a Single Connector
- Mobile Phones
- Tablets
- Bar Code Scanners
- Portable Devices

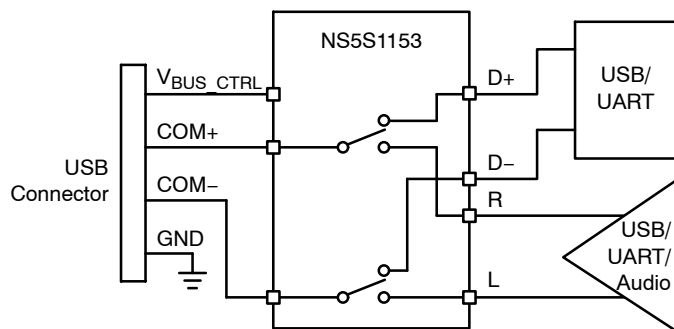

Figure 1. Application Diagram



ON Semiconductor®

<http://onsemi.com>

MARKING DIAGRAMS

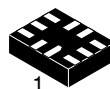

UQFN10
CASE 488AT

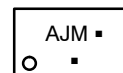

AJ = Specific Device Code
M = Date Code
▪ = Pb-Free Package

(Note: Microdot may be in either location)

ORDERING INFORMATION

Device	Package	Shipping†
NS5S1153MUTAG	UQFN10 (Pb-Free)	3000 / Tape & Reel

†For information on tape and reel specifications, including part orientation and tape sizes, please refer to our Tape and Reel Packaging Specifications Brochure, BRD8011/D.

NS5S1153

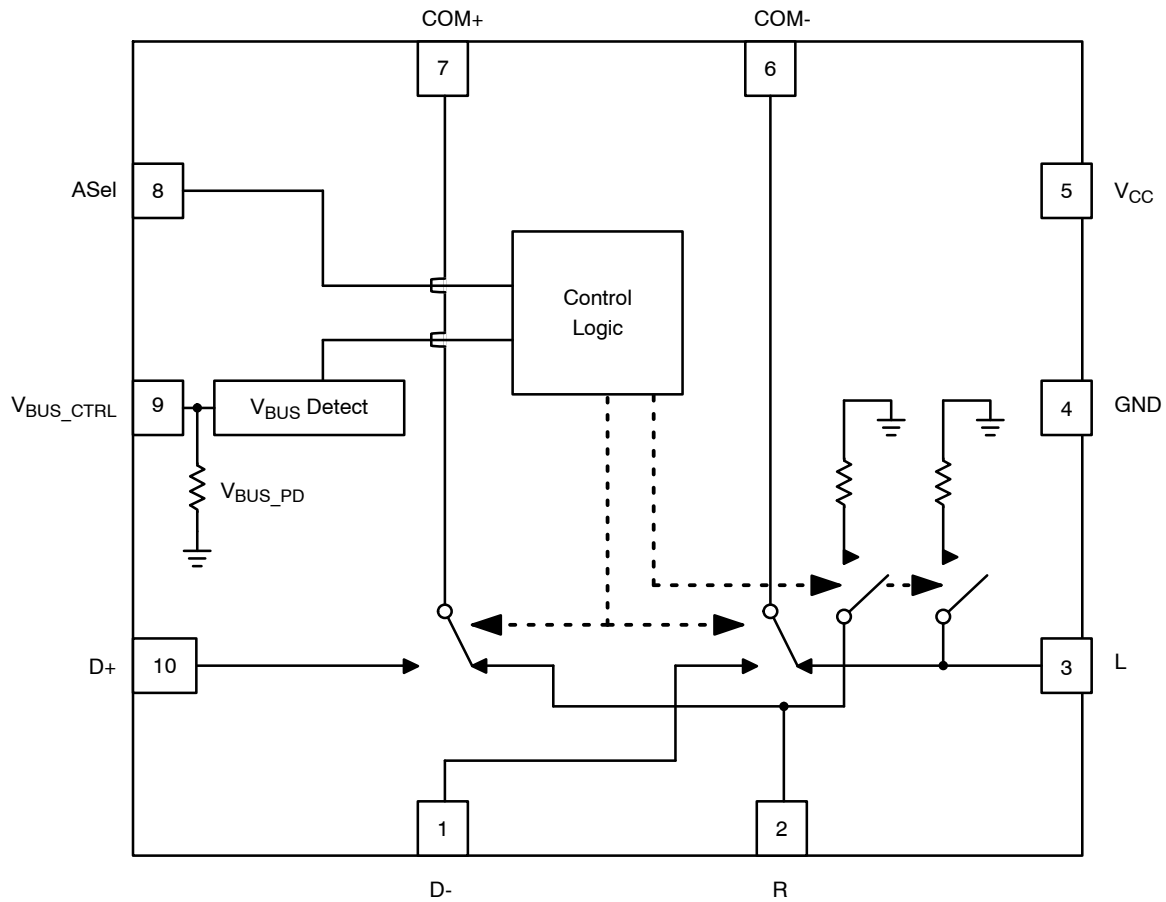

Figure 2. Functional Block Diagram
(Top View)

PIN DESCRIPTIONS

Pin #	Name	Direction	Description
1	D-	I/O	Negative Data Line for USB Signals
2	R	I/O	Right Line for Audio Signals
3	L	I/O	Left Line for Audio Signals
4	GND	Power	Ground
5	V _{CC}	Power	Power Supply
6	COM-	I/O	Left Audio / Negative Data Common Line
7	COM+	I/O	Right Audio / Positive Data Common Line
8	A _{SEL}	Input	Control Input Override Select Line
9	V _{BUS_CTRL}	Input	Control Input Select Line from V _{BUS}
10	D+	I/O	Positive Data Line for USB Signals

TRUTH TABLE

A _{SEL}	V _{BUS}	L, R	D+, D-	L, R SHUNT
Low	Low	ON	OFF	OFF
Low	High	OFF	ON	ON
High	X	ON	OFF	OFF

NS5S1153

OPERATING CONDITIONS

MAXIMUM RATINGS

Symbol	Pins	Parameter	Value	Unit
V _{CC}	V _{CC}	Positive DC Supply Voltage	-0.5 to +6.0	V
V _{BUS}	V _{BUS_CTRL}	V _{BUS} Control Input Voltage	-0.5 to +6.0	V
V _{IS}	D+ to COM+ D- to COM-	Analog Signal Voltage	-0.5 to +6.0	V
	R to COM+ L to COM-		-2.5 to V _{CC} + 0.5	
V _{IS}	COM+, COM-	DC Signal Voltage Tolerance (<24 hours)	5.25	V
V _{IN}	ASel	Control Input Override Voltage	-0.5 to +6.0	V
I _{CC}	V _{CC}	Positive DC Supply Current	50	mA
T _S		Storage Temperature	-65 to +150	°C
I _{IS_CON}	COM+, COM- R, L, D+, D-	Analog Signal Continuous Current—Closed Switch	± 100	mA
I _{IS_PK}	COM+, COM- R, L, D+, D-	Analog Signal Continuous Current 10% Duty Cycle	± 500	mA
I _{IN}	ASel	Control Input Override Current	1	mA
	V _{BUS_CTRL}	V _{BUS} Control Input Current	1	

Stresses exceeding Maximum Ratings may damage the device. Maximum Ratings are stress ratings only. Functional operation above the Recommended Operating Conditions is not implied. Extended exposure to stresses above the Recommended Operating Conditions may affect device reliability.

RECOMMENDED OPERATING CONDITIONS

Symbol	Pins	Parameter	Min	Max	Unit
V _{CC}	V _{CC}	Positive DC Supply Voltage	2.7	5.0	V
V _{BUS}	V _{BUS_CTRL}	V _{BUS} Control Input Voltage	GND	5.25	V
V _{IS}	D+ to COM+ D- to COM-	Analog Signal Voltage (Note 1)	GND	V _{CC}	V
	R to COM+ L to COM-		-2.0	V _{CC}	
V _{IN}	ASel	Control Input Override Voltage	GND	V _{CC}	V
T _A		Operating Temperature	-40	+85	°C

Minimum and maximum values are guaranteed through test or design across the Recommended Operating Conditions, where applicable. Typical values are listed for guidance only and are based on the particular conditions listed for section, where applicable. These conditions are valid for all values found in the characteristics tables unless otherwise specified in the test conditions.

1. In USB mode, any signal applied to the off-state audio inputs R, L may not swing below ground or above 1.5 V.

DC ELECTRICAL CHARACTERISTICS

CONTROL INPUT (Typical: T = 25°C, V_{CC} = 3.3 V)

Symbol	Pins	Parameter	Test Conditions	V _{CC} (V)	-40°C to +85°C			Unit
					Min	Typ	Max	
V _{IH}	A _{SEL}	Control Input HIGH Voltage		2.7	1.3	-	-	V
				3.3	1.4			
				4.2	1.5			
V _{IL}	A _{SEL}	Control Input LOW Voltage		2.7	-	-	0.4	V
				3.3			0.4	
				4.2			0.4	
I _{IN}	A _{SEL}	Current Input Leakage Current	0 ≤ V _{IS} ≤ V _{CC}	4.2	-	-	±50	nA
V _{IH}	V _{BUS_CTRL}	V _{BUS} Control Input HIGH Voltage		2.7	1.9	-	-	V
				3.3	2.2			
				4.2	2.7			
V _{IL}	V _{BUS_CTRL}	V _{BUS} Control Input LOW Voltage		2.7	-	-	0.8	V
				3.3			1.1	
				4.2			1.6	
I _{IN}	V _{BUS_CTRL}	V _{BUS} Current Input Leakage Current	0 ≤ V _{IS} ≤ V _{CC}	4.2	-	-	±25	μA

SUPPLY CURRENT AND LEAKAGE (Typical: T = 25°C, V_{CC} = 3.3 V)

Symbol	Pins	Parameter	Test Conditions	V _{CC} (V)	-40°C to +85°C			Unit
					Min	Typ	Max	
I _{NC,NO(OFF)}	D+, D-	OFF State Leakage	V _{BUS_CTRL} = 0 V, 4.2 V; V _{COM-} , V _{COM+} = 0 V, 4.2 V V _{D+} , V _{D-} = 4.2 V, 0 V or float V _L , V _R = float or 4.2 V, 0 V	4.2			±80	nA
I _{COM(ON)}	COM-, COM+	ON State Leakage	V _{BUS_CTRL} = 0 V, 4.2 V; V _{COM-} , V _{COM+} = 0 V, 4.2 V V _{D+} , V _{D-} = 4.2 V, 0 V or float V _L , V _R = float or 4.2 V, 0 V	4.2			±100	nA
I _{CC}	V _{CC}	Quiescent Supply	V _{IS} = GND to V _{CC} ; I _D = 0 A	4.2		21	35	μA
I _{OFF}	COM-, COM+	Power OFF Leakage	0 ≤ V _{IS} ≤ 4.2 V	0			50	μA

USB ON RESISTANCE (Typical: T = 25°C, V_{CC} = 3.3 V)

Symbol	Pins	Parameter	Test Conditions	V _{CC} (V)	-40°C to +85°C			Unit
					Min	Typ	Max	
R _{ON}	D+ to COM+ D- to COM-	On-Resistance	I _{ON} = 10 mA V _{IS} = 0 V to V _{CC}	2.7		3.0	5.5	Ω
				3.3		3.0	4.6	
				4.2		3.0	4.6	
R _{FLAT}	D+ to COM+ D- to COM-	On-Resistance Flatness	I _{ON} = 10 mA V _{IS} = 0 V to V _{CC}	2.7		0.08		Ω
				3.3		0.08		
				4.2		0.08		
ΔR _{ON}	D+ to COM+ D- to COM-	On-Resistance Matching	I _{ON} = 10 mA V _{IS} = 0 V to V _{CC}	2.7		0.03		Ω
				3.3		0.03		
				4.2		0.03		

AUDIO ON RESISTANCE (Typical: T = 25°C, V_{CC} = 3.3 V)

Symbol	Pins	Parameter	Test Conditions	V _{CC} (V)	-40°C to +85°C			Unit
					Min	Typ	Max	
R _{ON}	R to COM+ L to COM-	On-Resistance	I _{ON} = 10 mA V _{IS} = -1.5 to 1.5	2.7		3.0	4.6	Ω
				3.3		3.0	4.6	
				4.2		3.0	4.6	
R _{FLAT}	R to COM+ L to COM-	On-Resistance Flatness	I _{ON} = 10 mA V _{IS} = -1.5 to 1.5	2.7		0.11		Ω
				3.3		0.11		
				4.2		0.11		
ΔR _{ON}	R to COM+ L to COM-	On-Resistance Matching	I _{ON} = 10 mA V _{IS} = -0.85 to 0.85	2.7		0.03		Ω
				3.3		0.03		
				4.2		0.03		
R _{SH}	L, R	Shunt Resistance (Resistor + Switch)	I _{ON} = 10 mA	2.7		118	160	Ω
V _{BUS_PD}	V _{BUS_CTRL}	V _{BUS_CTRL} Pull-down Resistor	I _{ON} = 10 mA			530		kΩ

AC ELECTRICAL CHARACTERISTICS

TIMING/FREQUENCY (Typical: T = 25°C, V_{CC} = 3.3 V, R_L = 50 Ω, C_L = 35 pF, f = 1 MHz)

Symbol	Pins	Parameter	Test Conditions	V _{CC} (V)	-40°C to +85°C			Unit
					Min	Typ	Max	
t _{ON}		Turn-ON Time (Closed to Open) (Figures 8 and 9)		2.7 – 4.2	–	14	–	μs
t _{OFF}		Turn-OFF Time (Closed to Open) (Figures 8 and 9)		2.7 – 4.2	–	75	–	ns
T _{BBM}		Break-Before-Make Time (Figure 7)			–	7.0	–	μs
BW	D+ to COM+ D- to COM-	-3 dB Bandwidth (Figure 10)	C _L = 5 pF R _S = 50 Ω		–	900	–	MHz

ISOLATION (Typical: T = 25°C, V_{CC} = 3.3 V, R_L = 50 Ω, C_L = 5 pF)

Symbol	Pins	Parameter	Test Conditions	V _{CC} (V)	-40°C to +85°C			Unit
					Min	Typ	Max	
O _{IRR}	Open	OFF-Isolation (Figure 10)	f = 100 kHz, R _S = 50 Ω		–	-81	–	dB
X _{TALK}	COM+ to COM-	Non-Adjacent Channel Crosstalk (Figure 10)	f = 100 kHz, R _S = 50 Ω		–	-93	–	dB
THD+N		Total Harmonic Distortion + Noise	V _{BUS_CTRL} = 0 V A _{SEL} = 3.0 V f = 20 Hz to 20 kHz V _{COM} = 0.5 V _{pp} R _L = 600 Ω	3.0	–	0.001	–	%
THD		Total Harmonic Distortion	V _{BUS_CTRL} = 0 V A _{SEL} = 0 V, 3.6 V f = 1 kHz V _{COM} = ±2.0 V _{pp} R _L = 16 Ω	3.6	–	0.01	–	%
PSRR		Power Supply Rejection Ratio	f = 10 kHz R _{COM} = 50 Ω	3.0	–	60	–	dB

CAPACITANCE (Typical: T = 25°C, V_{CC} = 3.3 V, R_L = 50 Ω, C_L = 5 pF, f = 1 MHz, A_{SEL} = 0 V)

Symbol	Pins	Parameter	Test Conditions	-40°C to +85°C			Unit
				Min	Typ	Max	
C _{IN}	A _{SEL}	Control Pin Input Capacitance	V _{CC} = 0 V	–	2.6	–	pF
C _{ON}	D+ to COM+ D- to COM-	USB ON Capacitance	V _{BUS_CTRL} = 5 V	–	6.9	–	pF
C _{ON}	R to COM+ L to COM-	Audio ON Capacitance	V _{BUS_CTRL} = 0 V	–	9.3	–	pF
C _{OFF}	D+, D-	USB OFF Capacitance	V _{BUS_CTRL} = 0 V	–	4.8	–	pF
C _{OFF}	R, L	Audio OFF Capacitance	V _{BUS_CTRL} = 5 V	–	4.8	–	pF

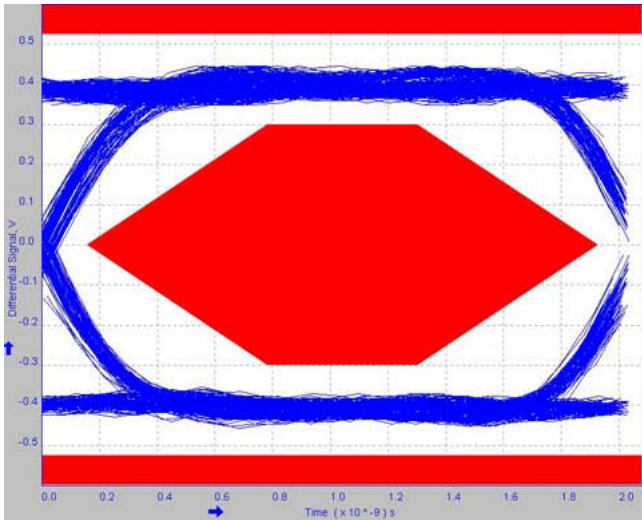

Figure 3. High Speed USB Eye Diagram of Signal Path without Switch

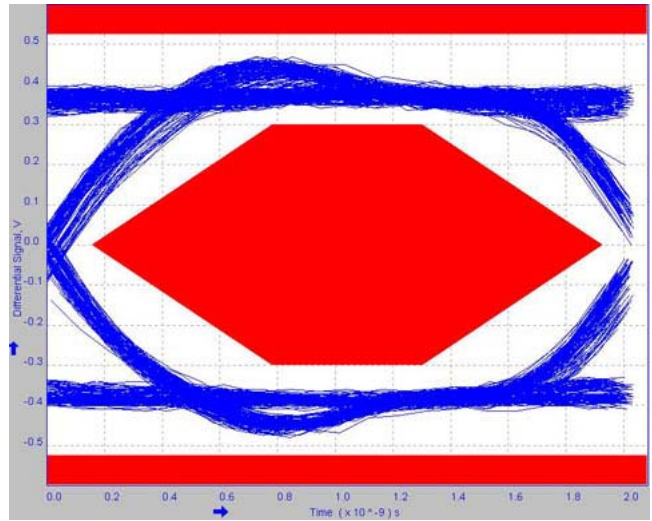

Figure 4. High Speed USB Eye Diagram of Signal Path with NS5S1153 ($V_{CC} = 3.6\text{ V}$)

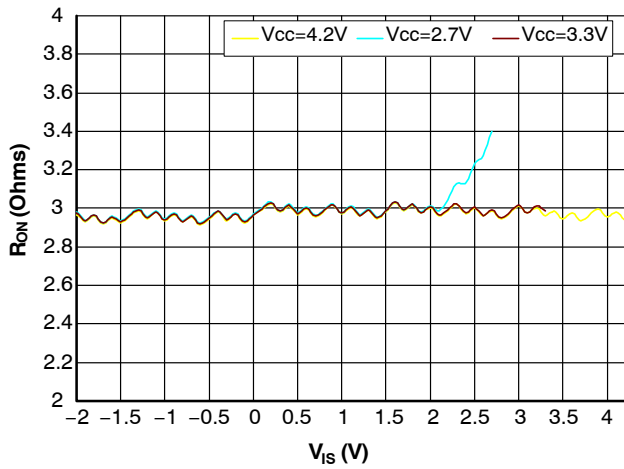

Figure 5. Audio ON Resistance vs. Signal Voltage @ $T = 25^{\circ}\text{C}$, $2.7\text{ V} \leq V_{CC} \leq 4.2\text{ V}$

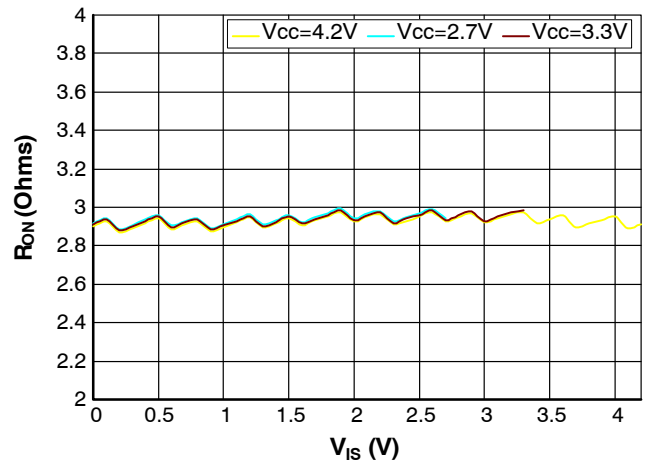

Figure 6. USB ON Resistance vs. Signal Voltage @ $T = 25^{\circ}\text{C}$, $2.7\text{ V} \leq V_{CC} \leq 4.2\text{ V}$

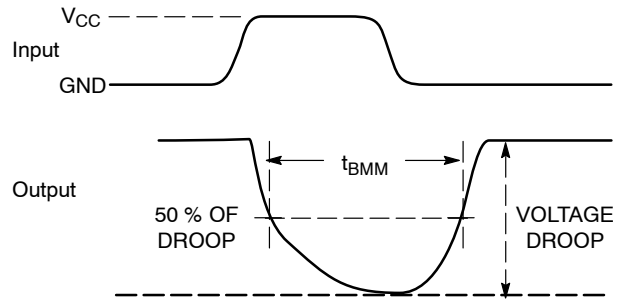
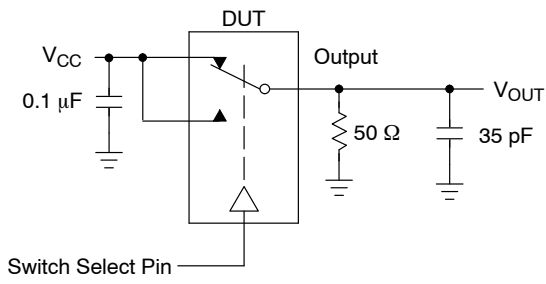

Figure 7. t_{BMM} (Time Break-Before-Make)

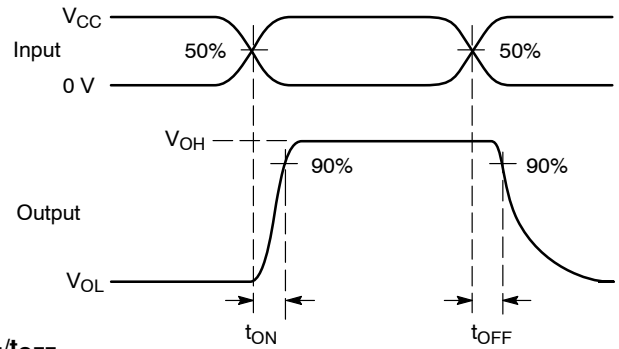
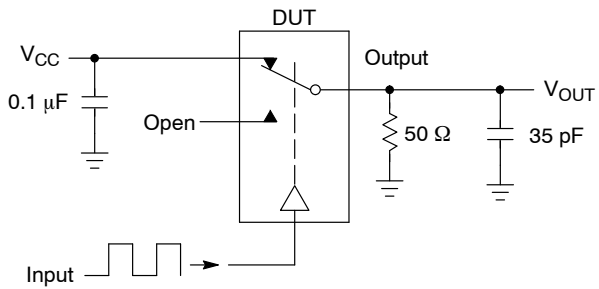

Figure 8. t_{ON}/t_{OFF}

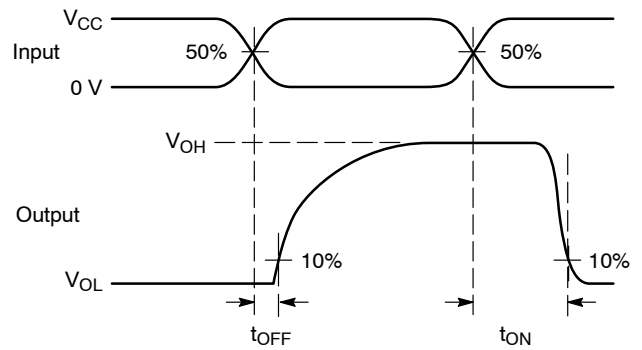
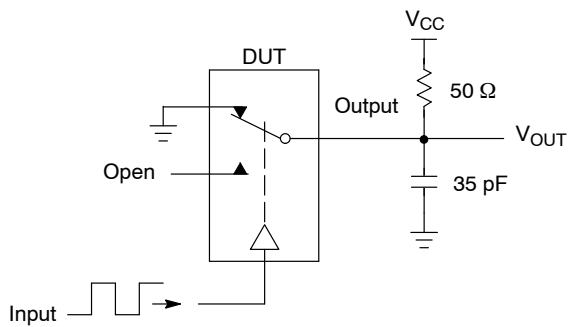
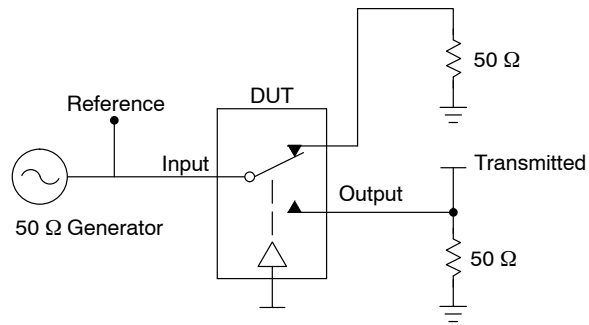

Figure 9. t_{ON}/t_{OFF}

NS5S1153



Channel switch control/s test socket is normalized. Off isolation is measured across an off channel. On loss is the bandwidth of an On switch. V_{ISO} , Bandwidth and V_{ONL} are independent of the input signal direction.

$$V_{ISO} = \text{Off Channel Isolation} = 20 \text{ Log} \left(\frac{V_{OUT}}{V_{IN}} \right) \text{ for } V_{IN} \text{ at } 100 \text{ kHz}$$

$$V_{ONL} = \text{On Channel Loss} = 20 \text{ Log} \left(\frac{V_{OUT}}{V_{IN}} \right) \text{ for } V_{IN} \text{ at } 100 \text{ kHz to } 50 \text{ MHz}$$

Bandwidth (BW) = the frequency 3 dB below V_{ONL}

V_{CT} = Use V_{ISO} setup and test to all other switch analog input/outputs terminated with 50 Ω

Figure 10. Off Channel Isolation/On Channel Loss (BW)/Crosstalk (On Channel to Off Channel)/ V_{ONL}

NS5S1153

PACKAGE DIMENSIONS

UQFN10 1.4x1.8, 0.4P
CASE 488AT-01
ISSUE A

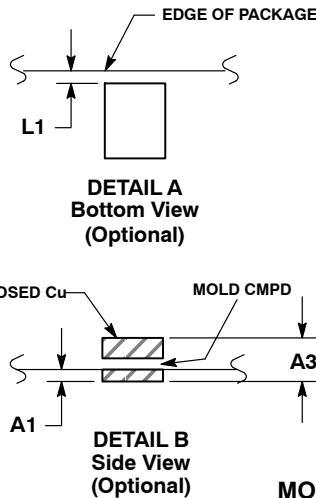
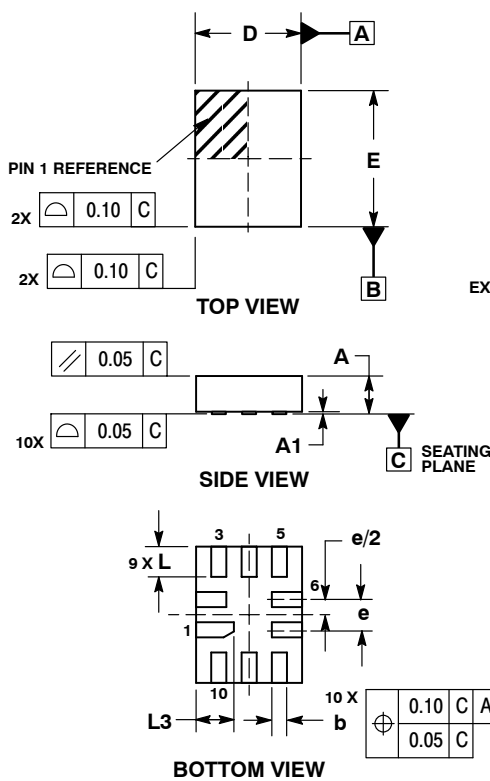

NOTES:

1. DIMENSIONING AND TOLERANCING PER ASME Y14.5M, 1994.
2. CONTROLLING DIMENSION: MILLIMETERS
3. DIMENSION b APPLIES TO PLATED TERMINAL AND IS MEASURED BETWEEN 0.25 AND 0.30 MM FROM TERMINAL.
4. COPLANARITY APPLIES TO THE EXPOSED PAD AS WELL AS THE TERMINALS.

DIM	MILLIMETERS	
	MIN	MAX
A	0.45	0.60
A1	0.00	0.05
A3	0.127	REF
b	0.15	0.25
D	1.40	BSC
E	1.80	BSC
e	0.40	BSC
L	0.30	0.50
L1	0.00	0.15
L3	0.40	0.60

MOUNTING FOOTPRINT

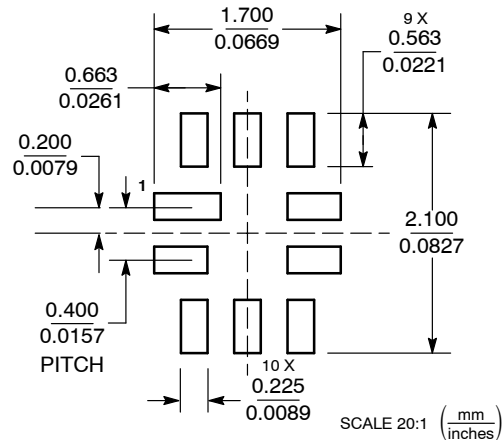

*For additional information on our Pb-Free strategy and soldering details, please download the ON Semiconductor Soldering and Mounting Techniques Reference Manual, SOLDERRM/D.

ON Semiconductor and are registered trademarks of Semiconductor Components Industries, LLC (SCILLC). SCILLC reserves the right to make changes without further notice to any products herein. SCILLC makes no warranty, representation or guarantee regarding the suitability of its products for any particular purpose, nor does SCILLC assume any liability arising out of the application or use of any product or circuit, and specifically disclaims any and all liability, including without limitation special, consequential or incidental damages. "Typical" parameters which may be provided in SCILLC data sheets and/or specifications can and do vary in different applications and actual performance may vary over time. All operating parameters, including "Typicals" must be validated for each customer application by customer's technical experts. SCILLC does not convey any license under its patent rights nor the rights of others. SCILLC products are not designed, intended, or authorized for use as components in systems intended for surgical implant into the body, or other applications intended to support or sustain life, or for any other application in which the failure of the SCILLC product could create a situation where personal injury or death may occur. Should Buyer purchase or use SCILLC products for any such unintended or unauthorized application, Buyer shall indemnify and hold SCILLC and its officers, employees, subsidiaries, affiliates, and distributors harmless against all claims, costs, damages, and expenses, and reasonable attorney fees arising out of, directly or indirectly, any claim of personal injury or death associated with such unintended or unauthorized use, even if such claim alleges that SCILLC was negligent regarding the design or manufacture of the part. SCILLC is an Equal Opportunity/Affirmative Action Employer. This literature is subject to all applicable copyright laws and is not for resale in any manner.

PUBLICATION ORDERING INFORMATION

LITERATURE FULFILLMENT:
Literature Distribution Center for ON Semiconductor
P.O. Box 5163, Denver, Colorado 80217 USA
Phone: 303-675-2175 or 800-344-3860 Toll Free USA/Canada
Fax: 303-675-2176 or 800-344-3867 Toll Free USA/Canada
Email: orderlit@onsemi.com

N. American Technical Support: 800-282-9855 Toll Free USA/Canada
Europe, Middle East and Africa Technical Support:
Phone: 421 33 790 2910
Japan Customer Focus Center
Phone: 81-3-5773-3850

ON Semiconductor Website: www.onsemi.com
Order Literature: <http://www.onsemi.com/orderlit>
For additional information, please contact your local Sales Representative

AMEYA360

Components Supply Platform

Authorized Distribution Brand :



Website :

Welcome to visit www.ameya360.com

Contact Us :

➤ Address :

401 Building No.5, JiuGe Business Center, Lane 2301, Yishan Rd
Minhang District, Shanghai , China

➤ Sales :

Direct +86 (21) 6401-6692

Email amall@ameya360.com

QQ 800077892

Skype [ameyasales1](#) [ameyasales2](#)

➤ Customer Service :

Email service@ameya360.com

➤ Partnership :

Tel +86 (21) 64016692-8333

Email mkt@ameya360.com