

TLE8102SG

Smart Dual Channel Powertrain Switch
coreFLEX

Automotive Power



Never stop thinking

Table of Contents

	Table of Contents	2
1	Overview	3
2	Overview	5
2.1	Terms	5
3	Pin Configuration	6
3.1	Pin Assignment	6
3.2	Pin Definitions and Functions	6
4	Maximum Ratings and Operating Conditions	7
4.1	Absolute Maximum Ratings	7
4.2	Operating Conditions	8
5	Electrical and Functional Description of Blocks	9
5.1	Power Supply	9
5.2	Parallel Inputs	9
5.3	Power Outputs	10
5.3.1	Timing Diagrams	10
5.3.2	Inductive Output Clamp	10
5.3.3	Protection Functions	11
5.3.3.1	Over Load Protection	11
5.3.3.2	Over Temperature Protection	13
5.3.4	Reverse Current	15
5.3.5	Reverse Polarity Protection	15
5.4	Diagnostic Functions	17
5.5	Current Sense	20
5.6	SPI Interface	23
5.6.1	SPI Signal Description	23
5.6.2	Daisy Chain Capability	24
5.7	Timing Diagrams	26
6	SPI Control	27
7	Application Description	30
8	Package Outlines	32
9	Revision History	33



1 Overview

Features

- Overload Protection
- DMOS Overtemperature protection
- Open load detection
- Current limitation
- Low quiescent current mode
- 3.3 V μ C compatible input
- Electrostatic discharge (ESD) protection
- Green Product (RoHS compliant)
- AEC Qualified

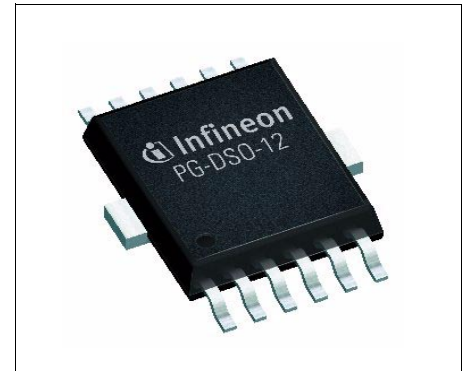

PG-DSO-12-11

Description

- Proportional load current sense with improved Precision:
+/- 6% at $I_D=3A$ and +/-3% Current Sense Temperature Deviation referring to $T_J=25^\circ C$
- Two Low-Side Channels with $R_{ON(max. @ 150^\circ C)} = 360m\Omega$.
- IC Overtemperature warning
- 8-Bit SPI (for diagnosis and control)
- Short to GND detection
- Programmable overload behaviour

Dual Current Sense Low-Side Switch in Smart Power Technology (SPT) with two open drain DMOS output stages. The TLE8102SG is protected by embedded protection functions and designed for automotive applications. The output stages can be controlled directly by parallel inputs for PWM applications (e.g. Oxygen Probe Heater) or by SPI. All output stages can provide a load current proportional sense signal. Diagnosis can be read from an 8-bit SPI or by the external fault pin.

Type	Package	Marking
TLE8102SG	PG-DSO-12-11	TLE8102SG

Parameter Summary

Parameter	Symbol	Value	Unit
Supply voltage	V_{DD}	4.5 ... 5.5	V
Drain source voltage	$V_{DS(CL)}$	48 ... 60	V
On resistance	$R_{ON(max. @ 150^{\circ}C)}$	0.36	Ω

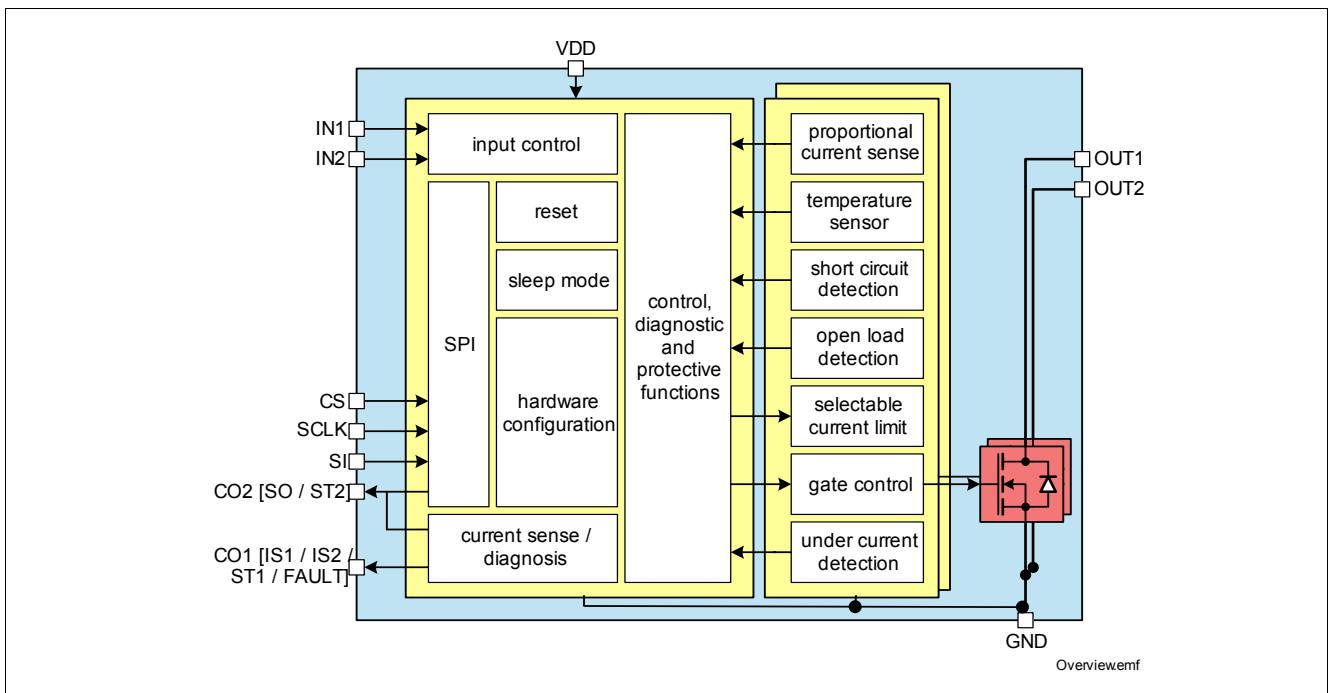

Figure 1 Block Diagram

2 Overview

2.1 Terms

Figure 2 shows all terms used in this Target Data Sheet.

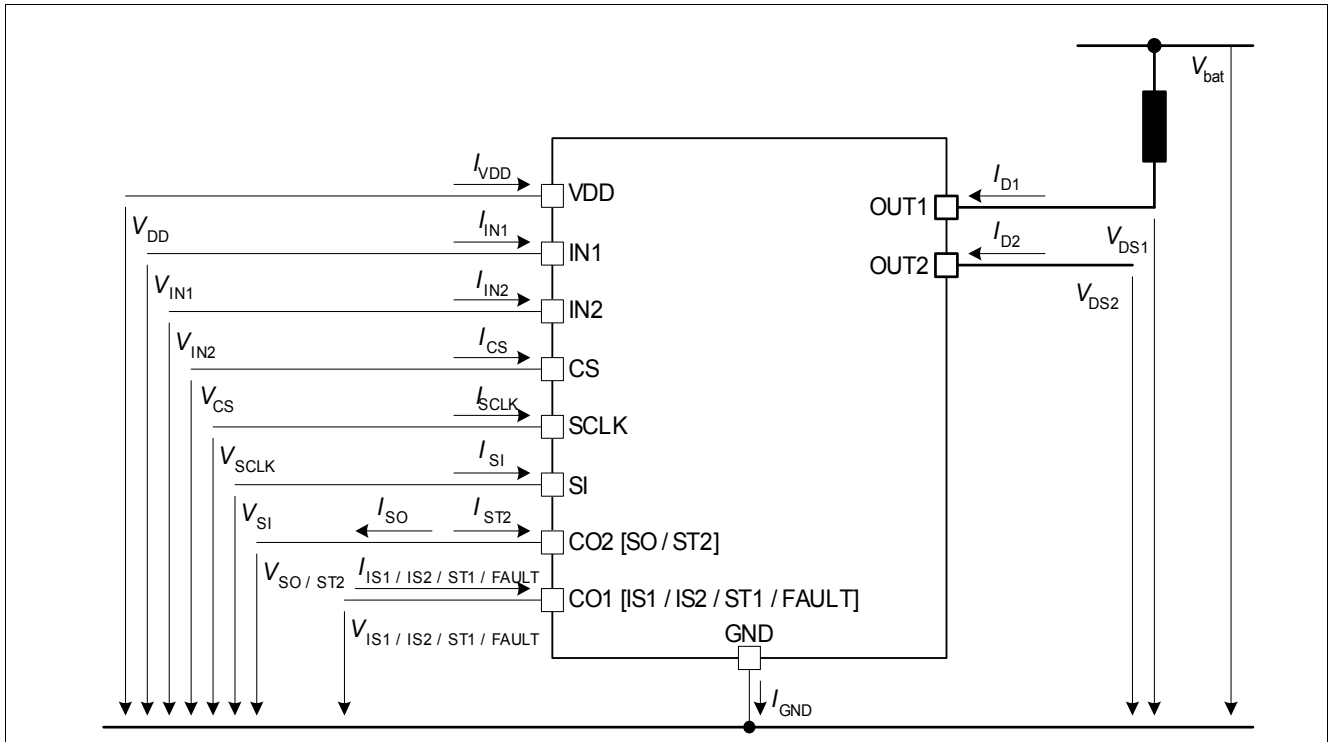

Figure 2 Terms

In all tables of electrical characteristics is valid: Channel related symbols without channel number are valid for each channel separately (e.g. V_{DS} specification is valid for V_{DS1} and V_{DS2}).

3 Pin Configuration

3.1 Pin Assignment

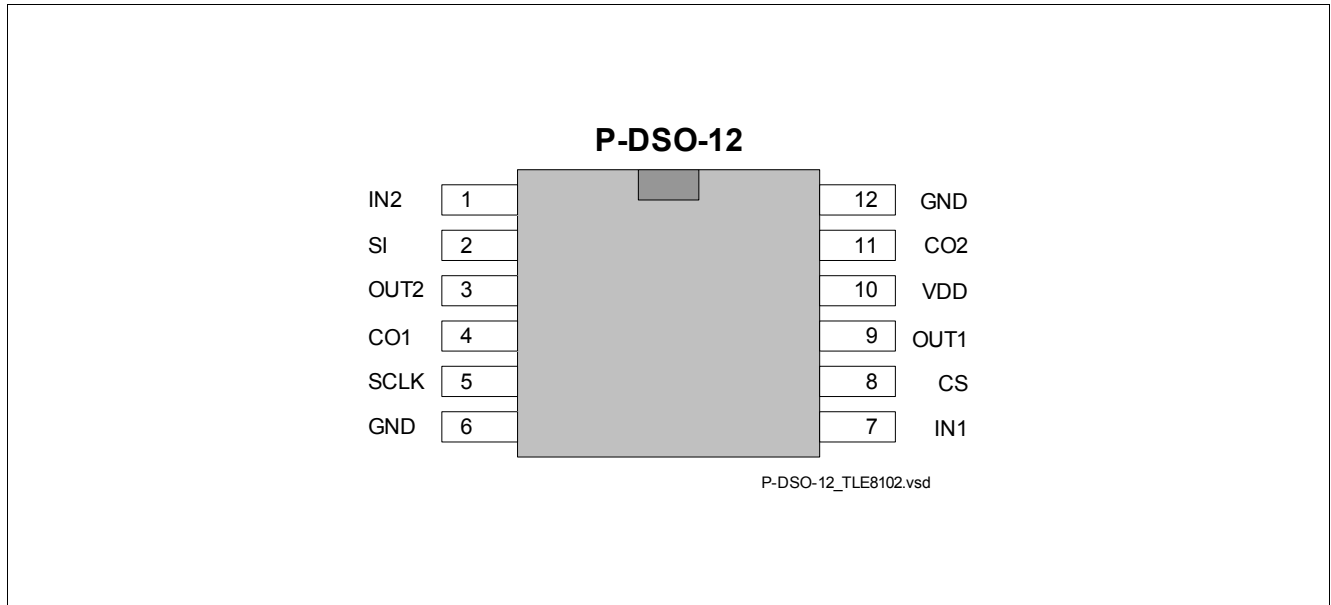

Figure 3 Pin Configuration (top view)

Both GND pins and the heat sink must be connected to GND externally.

3.2 Pin Definitions and Functions

Pin	Symbol	Function
1	IN2	Input Channel 2
2	SI	SPI Signal In
3	OUT2	Power Output Channel 2
4	CO1	Current Sense 1/2/Fault/Status Ch1
5	SCLK	SPI Clock
6	GND	Ground
7	IN1	Input Channel 1
8	CS	SPI Chip Select
9	OUT1	Power Output Channel 1
10	V _{DD}	Supply Voltage
11	CO2	SPI Signal Out/Status Ch2
12	GND	Ground

4 Maximum Ratings and Operating Conditions

4.1 Absolute Maximum Ratings

Absolute Maximum Ratings ¹⁾

$T_j = -40 \text{ °C}$ to $+150 \text{ °C}$; all voltages with respect to ground, positive current flowing into pin (unless otherwise specified)

Pos.	Parameter	Symbol	Limit Values		Unit	Conditions
			Min.	Max.		
4.1.1	Supply Voltage	V_{DD}	-0.3	7	V	–
4.1.2	Continuous Drain Source Voltage (OUT1 to OUT2)	V_{DS}	-0.3	48	V	–
4.1.3	Input Voltage, All Inputs and Data outputs, Sense Lines	V_{IN}	-0.3	7	V	–
4.1.4	Output Current per Channel ²⁾	I_D	-3	$I_{D(lim1,2) \text{ min.}}$	A	Output ON
4.1.5	Maximum Voltage for short circuit Protection (single event) ³⁾	$V_{SC, \text{ single}}$	–	48	V	Current Limit 2, slew rate 1 (default setting)
			–	32	V	Current Limit 2, slew rate 2
			–	18	V	Current Limit 1, slew rate 1 or 2
4.1.6	Electrostatic Discharge Voltage (human body model) according to EIA/JESD22-A114-E	V_{ESD}	-4000	4000	V	Output Pins
			-2000	2000	V	All other Pins
4.1.7	DIN Humidity Category, DIN 40 040		E			–
4.1.8	IEC Climatic Category, DIN IEC 68-1		40/150/ 56			–

1) Not subject to production test, specified by design.

2) Output current rating as long as maximum junction temperature is not exceeded. The maximum output current in the application has to be calculated using R_{thJA} depending on mounting conditions.

3) Device mounted on PCB (50 mm × 50 mm × 1.5 mm epoxy, FR4) with 6 cm² copper heatsink area (one layer, 70 μm thick); PCB in test chamber with blown air.

Note: Stresses above the ones listed here may cause permanent damage to the device. Exposure to absolute maximum rating conditions for extended periods may affect device reliability.

Note: Integrated protection functions are designed to prevent IC destruction under fault conditions described in the data sheet. Fault conditions are considered as “outside” normal operating range. Protection functions are not designed for continuous repetitive operation.

4.2 Operating Conditions

Pos.	Parameter	Symbol	Limit Values			Unit	Conditions
			Min.	Typ.	Max.		
4.2.1	Output Clamping Energy (single event), linearly decreasing current ¹⁾	E_{AS}	–	–	75	mJ	$I_{D(0)} = 2 \text{ A}$, $T_{J(0)} = 150 \text{ °C}$, max. 100 cycles over lifetime

Thermal Resistance

4.2.2	Junction to case	R_{thJSP}	–	1.3	2	K/W	$P_v = 2 \text{ W}$
4.2.3	Junction to ambient (see Figure 4)	R_{thJA}	–	25	–	K/W	$P_v = 2 \text{ W}$

Temperature Range

4.2.4	Operating Temperature Range	T_j	-40	–	150	°C	–
4.2.5	Storage Temperature Range	T_{stg}	-55	–	150	°C	–

1) Pulse shape represents inductive switch off: $I_D(t) = I_{D(0)} \times (1 - t / t_{pulse})$; $0 < t < t_{pulse}$

Note: Within the functional range the IC operates as described in the circuit description. The electrical characteristics are specified within the conditions given by the related electrical characteristics table.

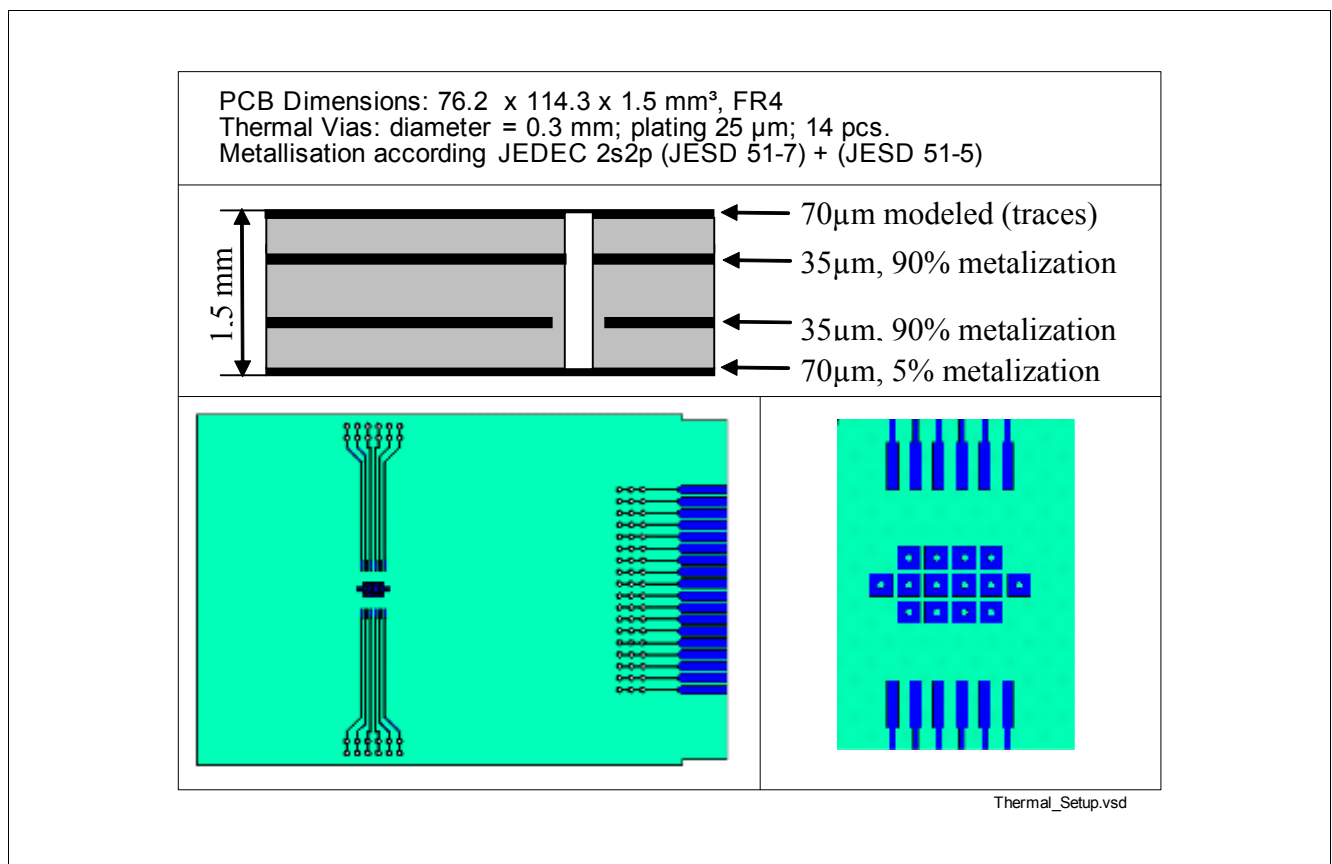

Figure 4 Thermal Simulation - PCB set-up

5 Electrical and Functional Description of Blocks

5.1 Power Supply

The TLE8102SG is supplied by power supply line V_{DD} , used for the digital as well as the analog functions of the device including the gate control of the power stages. A capacitor between pins V_{DD} to GND is recommended.

The TLE8102SG can be programmed via SPI to enter sleep mode. In sleep mode, all outputs are turned off and all diagnosis and biasing circuits are disabled. These actions reduce the quiescent current consumption from the power supply. However, the SPI configuration registers (except for the channel on/off register) are not reset when the TLE8102SG enters sleep mode. To exit sleep mode, a wake up command must be sent via SPI.

Electrical Characteristics: Power Supply

$V_{DD} = 4.5 \text{ V to } 5.5 \text{ V}$, $T_j = -40 \text{ }^\circ\text{C to } +150 \text{ }^\circ\text{C}$, (unless otherwise specified)

all voltages with respect to ground, positive current flowing into pin

Pos.	Parameter	Symbol	Limit Values			Unit	Conditions
			Min.	Typ.	Max.		
5.1.1	Supply Voltage	V_{DD}	4.5	–	5.5	V	–
5.1.2	Supply Current	I_{VDD}	–	–	5	mA	–
5.1.3	Supply Current in Sleep Mode	$I_{VDD(\text{sleep})}$	–	–	10	μA	–
5.1.4	Wake up Time (after sleep mode) ¹⁾	t_{wake}	–	–	100	μs	–

1) Not subject to production test, specified by design.

5.2 Parallel Inputs

There are two input pins available on the TLE8102SG to control the output stages.

Each input signal controls the output stages of its assigned channel. For example, IN1 controls OUT1 and IN2 controls OUT2. Please refer to [Figure 5](#) for details. The input pins are active high and each have an integrated pull-down current source. A comparator with hysteresis determines the state of the signal on IN_n . The zener diode protects the input circuit against ESD pulses.

The BOL bit can be set via SPI. This bit determines if the output is exclusively controlled by the IN_n signals, exclusively controlled by the corresponding data bits CHn_{IN} or by a Boolean OR or AND operation of the two inputs. The default setting of the BOL bits programs the outputs to be controlled exclusively by the IN_n signals.

The SLE_n bit can be set via SPI. This bit sets the slew rate of its assigned channel by selecting either slew rate 1 or slew rate 2. The slew rate also changes the over load switch off delay time (only for current limit 2).

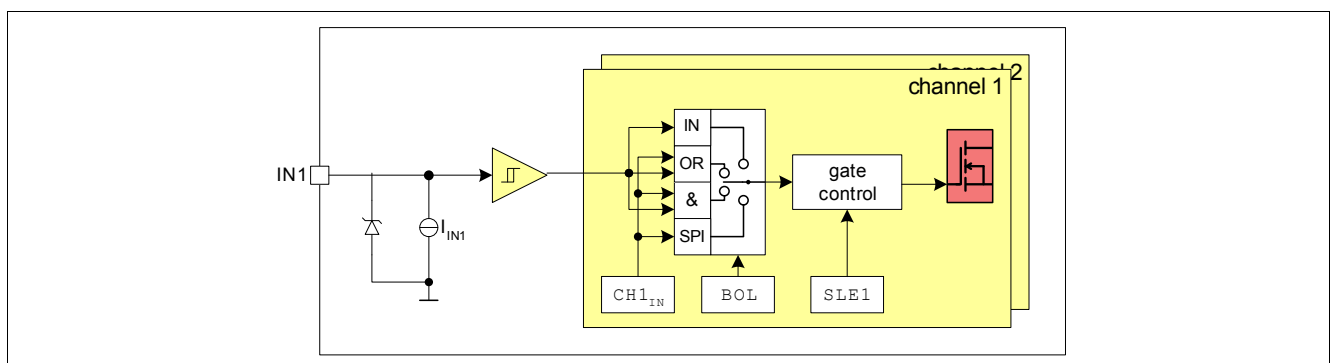

Figure 5 Input Control and Boolean Operator

Electrical Characteristics: Parallel Inputs

$V_{DD} = 4.5 \text{ V to } 5.5 \text{ V}$, $T_j = -40 \text{ }^\circ\text{C to } +150 \text{ }^\circ\text{C}$, (unless otherwise specified)

all voltages with respect to ground, positive current flowing into pin

Pos.	Parameter	Symbol	Limit Values			Unit	Conditions
			Min.	Typ.	Max.		
5.2.1	Input Low Voltage	V_{INL}	–	–	1.0	V	–
5.2.2	Input High Voltage	V_{INH}	2.0	–	–	V	–
5.2.3	Input Voltage Hysteresis ¹⁾	V_{INHys}	100	200	400	mV	–
5.2.4	Input Pull-down Current (IN1 to IN2)	$I_{IN(1 \dots 2)}$	20	50	100	μA	–

1) Not subject to production test, specified by design.

5.3 Power Outputs

5.3.1 Timing Diagrams

The power transistors are switched on and off with a dedicated slope either via the parallel inputs or by the CHn_{IN} bits of the serial peripheral interface SPI. The switching times t_{ON} and t_{OFF} are designed equally. The switching time of each channel can be selected via SPI by programming the $SLEn$ bit of the desired output. See [Figure 6](#) for details

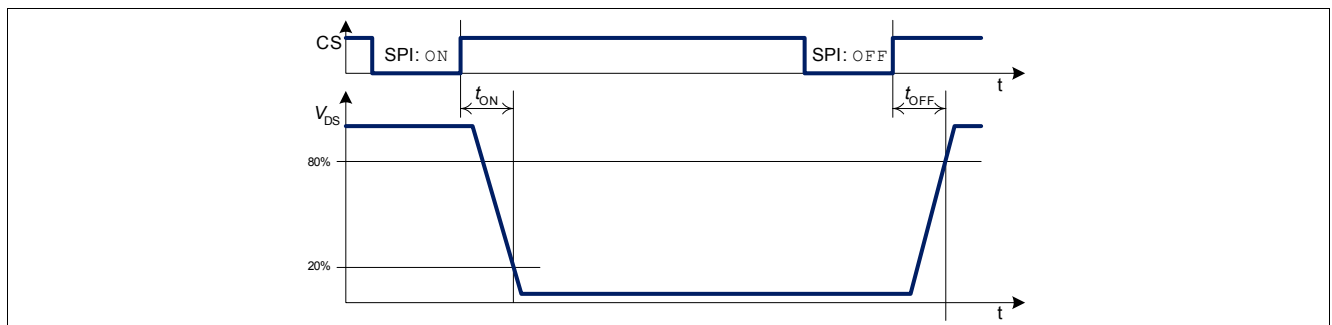

Figure 6 Switching a Resistive Load

5.3.2 Inductive Output Clamp

When switching off inductive loads, the potential at pin OUT rises to $V_{DS(CL)}$, as the inductance continues to drive current. The inductive output clamp is necessary to prevent destruction of the device. See [Figure 7](#) for details. The maximum allowed load inductance and current, however, are limited.

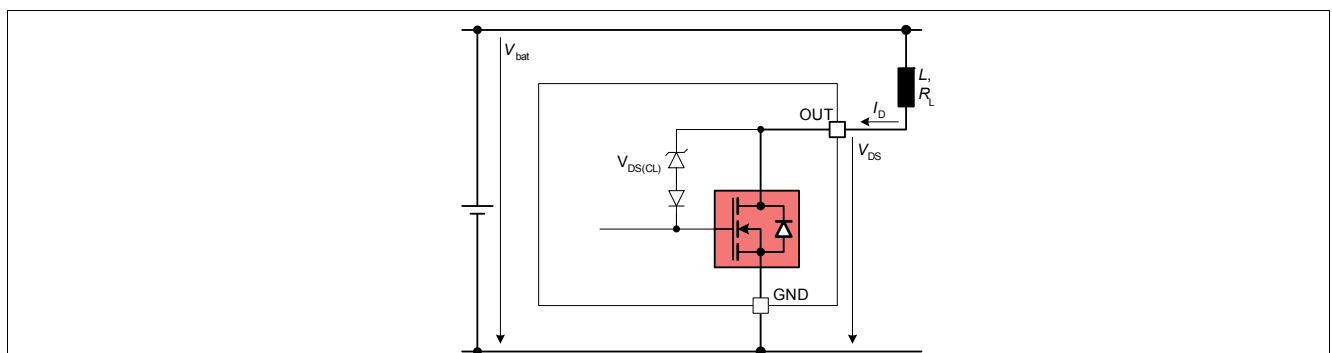

Figure 7 Inductive Output Clamp

Maximum Load Inductance

During demagnetization of inductive loads, energy has to be dissipated in the TLE8102SG. This energy can be calculated with following equation:

$$E = V_{DS(CL)} \cdot \left[\frac{V_{bat} - V_{DS(CL)}}{R_L} \cdot \ln \left(1 - \frac{R_L \cdot I_D}{V_{bat} - V_{DS(CL)}} \right) + I_D \right] \cdot \frac{L}{R_L}$$

The equation simplifies under the assumption of $R_L = 0$:

$$E = \frac{1}{2} L I_D^2 \cdot \left(1 - \frac{V_{bat}}{V_{bat} - V_{DS(CL)}} \right)$$

The energy, which is converted into heat, is limited by the thermal design of the component.

5.3.3 Protection Functions

The TLE8102SG provides embedded protective functions. Integrated protection functions are designed to prevent IC destruction under fault conditions described in this data sheet. Fault conditions are considered “outside” the normal operating range. Protection functions are not designed for continuous repetitive operation.

Over load and over temperature protections are implemented in the TLE8102SG. **Figure 8** gives an overview pf the protective functions.

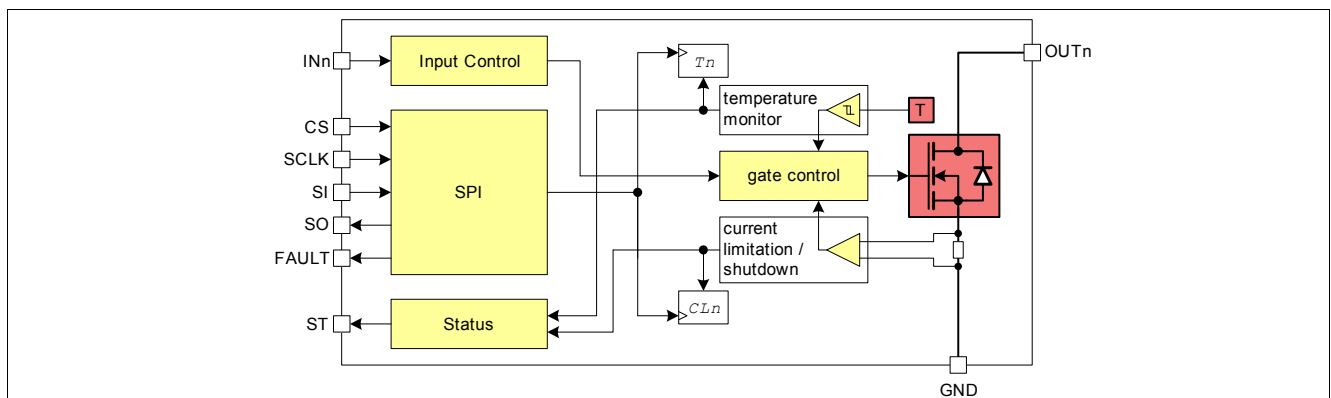

Figure 8 Protection Functions

5.3.3.1 Over Load Protection

The TLE8102SG is protected in case of over load or short circuit of the load. If the device is programmed for current limitation (current limit 1), the current is limited to $I_{DS(lim1)}$. After time $t_{d(fault)}$, the corresponding over load flag CLn is set. If using the status outputs for diagnosis, the over load flag is cleared immediately after the over load condition is no longer present. If using the SPI interface and fault pin for diagnosis, the over load flag of the affected channel is cleared by the rising edge of the \overline{CS} signal after a successful SPI transmission.

If the TLE8102SG is programmed for current shutdown (current limit 2), the current threshold is $I_{DS(lim2)}$. However, unlike in current limit 1, after time $t_{d(fault)}$, the affected channel is turned off and the according over load flag CLn is set. To turn on the channel again, this overload latch has to be reset by turning off the affected channel with either the parallel input or SPI. In addition, the switch off delay time can be programmed by changing the slew rate setting. If using the SPI interface and fault pin for diagnosis in case of current limit 2, the over load flag of the affected channel is cleared by the rising edge of the CS signal after a successful SPI transmission when the IN-Pin is high.

In both cases, the channel may shut down due to over temperature.

For timing information, please refer to [Figure 9](#) and [Figure 10](#) for details.

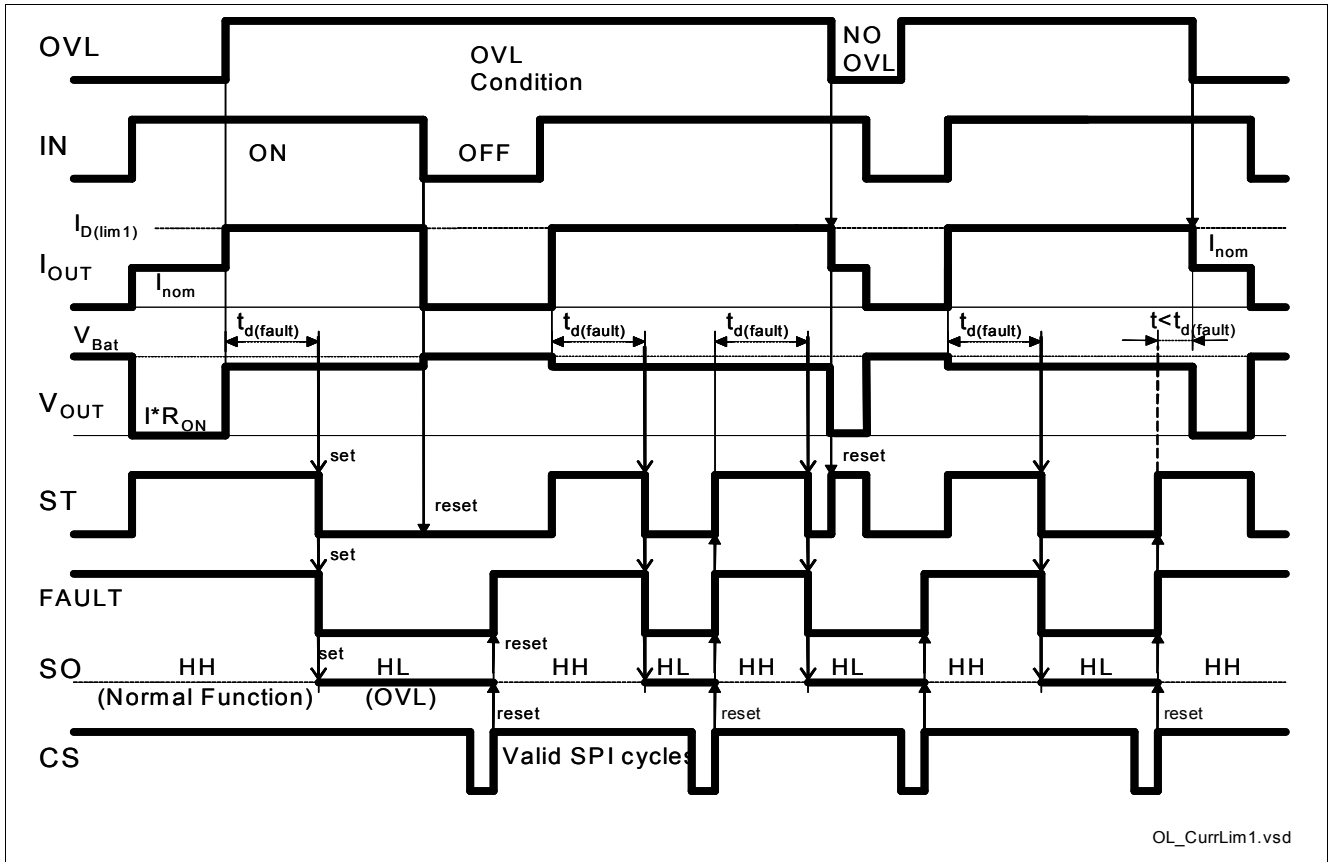

Figure 9 Over Load Behavior - Current Limitation (current limit 1)

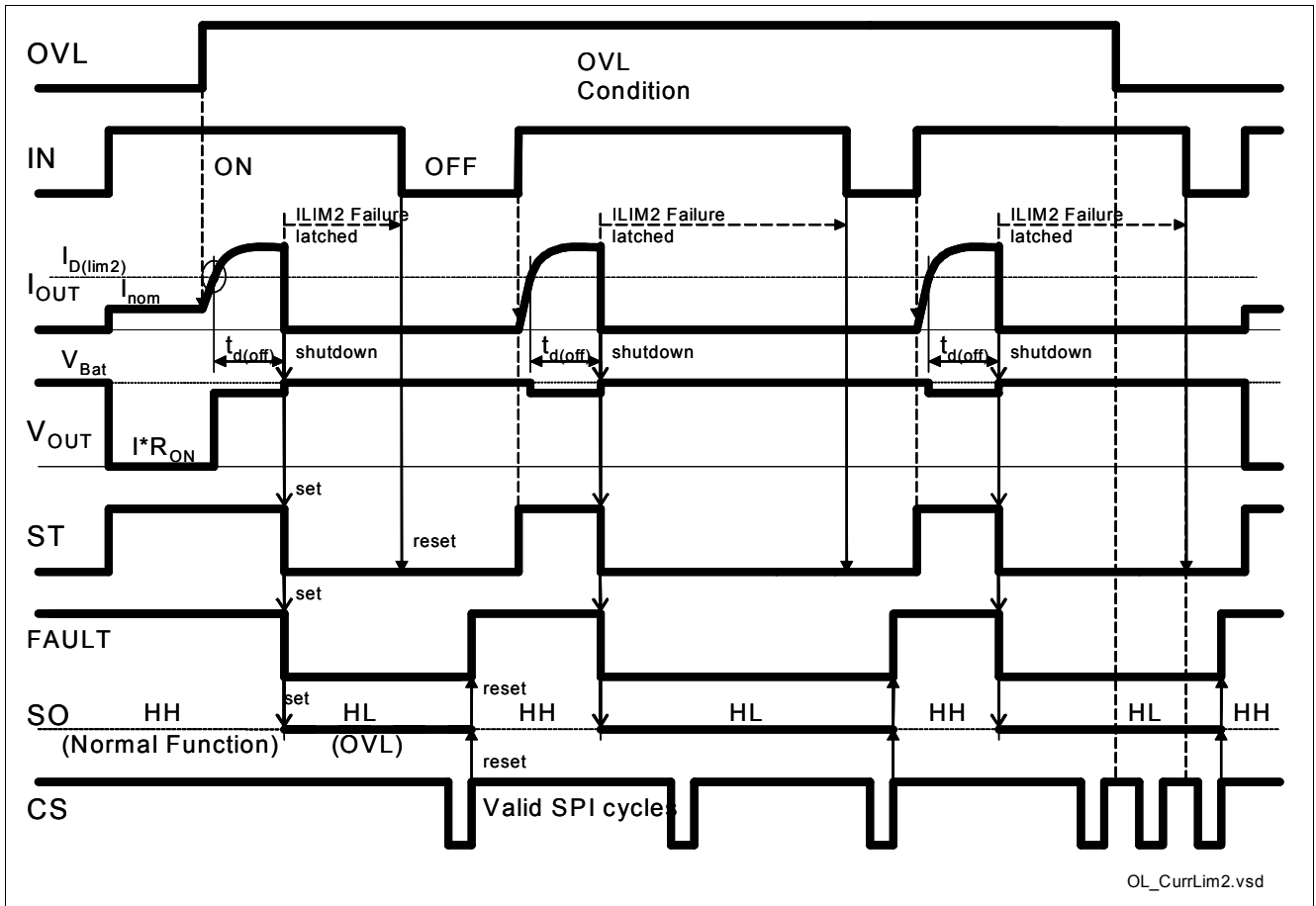

Figure 10 Over Load Behavior - Latched Shutdown (current limit 2)

5.3.3.2 Over Temperature Protection

A dedicated temperature sensor for each channel detects if the temperature of its channel exceeds the over temperature shutdown threshold. If the channel temperature exceeds the over temperature shutdown threshold, the overheated channel is switched off immediately to prevent destruction. At the same time (no delay), the over temperature flag T_n is set. If the status outputs are used for diagnosis, the over temperature flag is cleared immediately after the over temperature condition is no longer present. If using the SPI interface and fault pin for diagnosis, the over temperature flag of the affected channel is cleared by the rising edge of the \overline{CS} signal after a successful SPI transmission.

The restart response of the channel can be programmed via SPI. If automatic autorestart is selected, after cooling down, the channel is switched on again with thermal hysteresis ΔT_j . If latching shutdown is selected, the channel remains switched off even after cooling down. The channel can be restarted only if first turned off with either the parallel input or SPI. In addition, the channel must first be turned off before the the over temperature flag of the affected channel can be cleared by the rising edge of the \overline{CS} signal after a successful SPI transmission.

For timing information, please refer to [Figure 11](#) and [Figure 12](#) for details.

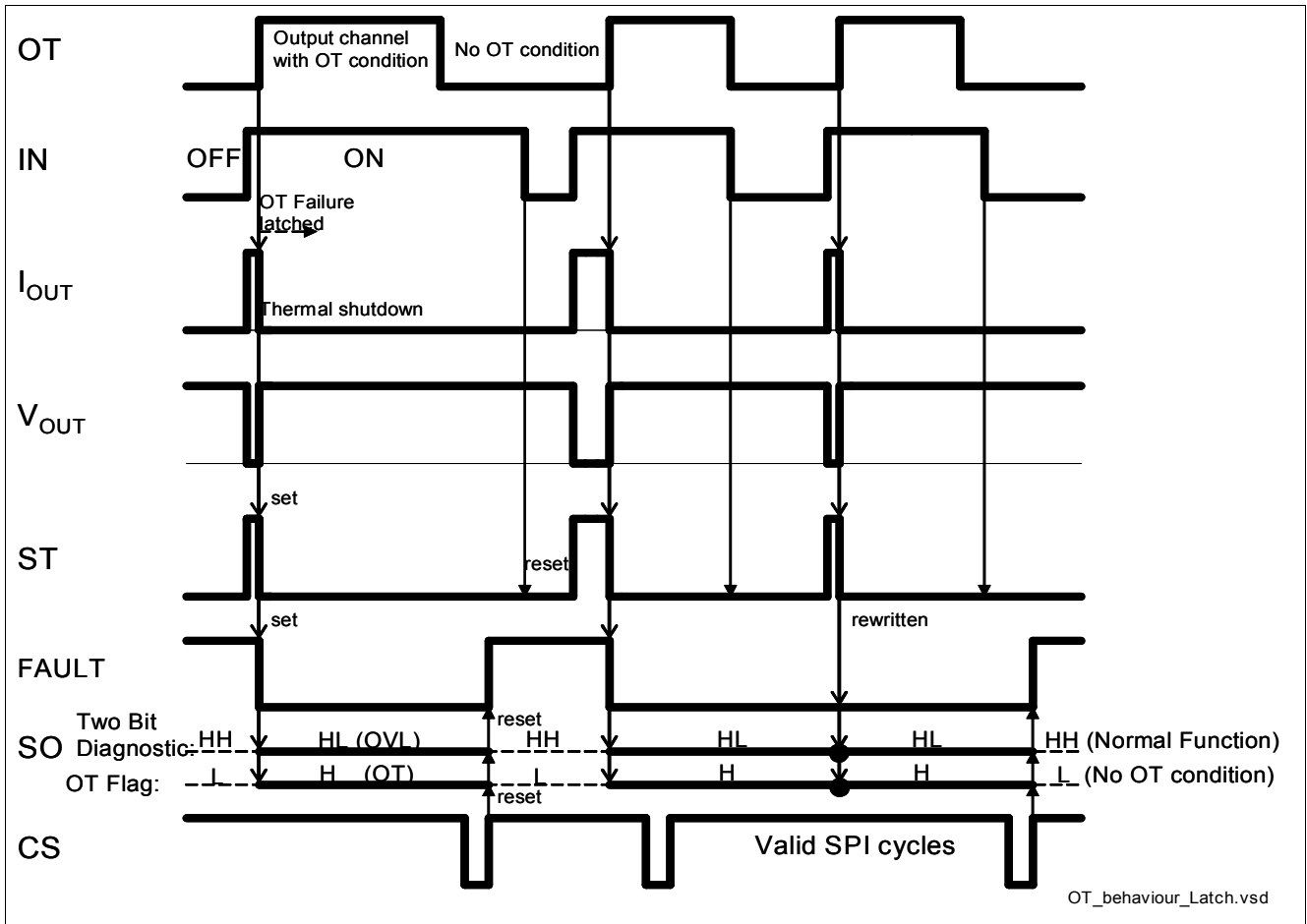

Figure 12 Over Temperature Behavior - Latched Shutdown

5.3.4 Reverse Current

In the case of reverse polarity when outputs are turned on, the power stages of the TLE8102SG are able to conduct reverse current I_{rev} , defined as current that flows from ground to the output pin. Please note that neither the over load, over temperature, nor current sense diagnostics are functional in reverse current operation. Additionally, it is possible for the supply current I_{VDD} to be greater than 5 mA.

5.3.5 Reverse Polarity Protection

In the case of reverse polarity when outputs are turned off, the intrinsic body diode of the power transistor causes power dissipation. The reverse current through the intrinsic body diode has to be limited by the connected load. The V_{DD} supply pin must be protected against reverse polarity externally. Please note that neither the over load, over temperature, nor current sense diagnostics are functional in reverse current operation.

Electrical Characteristics: Power Outputs
 $V_{DD} = 4.5 \text{ V to } 5.5 \text{ V}$, $T_j = -40 \text{ °C to } +150 \text{ °C}$, (unless otherwise specified)

all voltages with respect to ground, positive current flowing into pin

Pos.	Parameter	Symbol	Limit Values			Unit	Conditions
			Min.	Typ.	Max.		
5.3.1	ON Resistance	$R_{DS(ON)}$	–	0.18	–	Ω	$T_J = 25 \text{ °C}^{1)}$ $V_{DD} = 5 \text{ V}$, $I_D = 2 \text{ A}$
			–	0.27	–	Ω	$T_J = 125 \text{ °C}^{1)}$ $V_{DD} = 5 \text{ V}$, $I_D = 2 \text{ A}$
			–	0.3	0.36	Ω	$T_J = 150 \text{ °C}$, $V_{DD} = 5 \text{ V}$, $I_D = 2 \text{ A}$
5.3.2	Output Clamping Voltage	$V_{DS(CL)}$	48	–	60	V	output OFF
5.3.3	Current Limit 1: Current limitation	$I_{D(lim1)}$	5	6.5	8	A	–
5.3.4	Current Limit 2: Overload switch off	$I_{D(lim2)}$	9	10.5	12	A	$V_{DD} \geq 5 \text{ V}$
			9	–	12	A	$V_{DD} < 5 \text{ V}$, $T_J \leq 125 \text{ °C}$
			8	–	12	A	$V_{DD} < 5 \text{ V}$, $T_J > 125 \text{ °C}^{1)}$
5.3.5	Reverse Current per channel ¹⁾²⁾	I_{rev}	–	–	2	A	–
5.3.6	Output Leakage Current	$I_{D(lkg)}$	–	–	5	μA	Sleep mode active
5.3.7	Turn-On Time 1	t_{ON}	–	5	10	μs	$I_D = 2 \text{ A}$, resistive load
	Turn-On Time 2		–	20	50		
5.3.8	Turn-Off Time 1	t_{OFF}	–	5	10	μs	$I_D = 2 \text{ A}$, resistive load
	Turn-Off Time 2		–	20	50		
5.3.9	Turn On slew rate	s_{ON}	–	–	–	V/ μs	$V_{bat} = 14 \text{ V}$, $I_D = 2 \text{ A}$, resistive load, U_{DS} = 80% to 30%
	Slew rate 1		1	5	20		
	Slew rate 2		–	1	5		
5.3.10	Turn Off slew rate	s_{OFF}	–	–	–	V/ μs	$V_{bat} = 14 \text{ V}$, $I_D = 2 \text{ A}$, resistive load, U_{DS} = 30% to 80%
	Slew rate 1		1	5	20		
	Slew rate 2		–	1	5		
5.3.11	IC Overtemperature Warning ¹⁾	T_w	155	–	185	$^{\circ}\text{C}$	–
	Hysteresis ¹⁾	$T_{(w)hys}$	–	10	–	K	–
5.3.12	Channel Overtemp. Shutdown ¹⁾	$T_{th(sd)}$	170	–	200	$^{\circ}\text{C}$	–
	Hysteresis ¹⁾	$T_{(sd)hys}$	–	10	–	K	–

1) Not subject to production test, specified by design.

 2) Device functions normally, but supply current I_{VDD} can be greater than 5 mA.

5.4 Diagnostic Functions

The TLE8102SG provides diagnosis information about the device and about the load. The following diagnosis functions are implemented:

- The protective functions (flags CLn and Tn) of channel n are registered in the diagnosis flag Pn .
- The open load diagnosis of channel n is registered in the diagnosis flag OLn .
- The under current diagnosis of channel n is registered in the diagnosis flag UCn .
- The short to ground monitor information of channel n is registered in the diagnosis flag SGn .

The diagnosis information of the TLE8102SG can either be accessed by status (ST) pins or the SPI interface and/or fault pin. With the exception of over temperature, a fault is only recognized if it lasts longer than the fault delay time $t_{d(\text{fault})}$. If using the status pins for diagnosis, the status pins change state in normal operation to match the input signal of the corresponding channel. If a fault condition appears and the fault delay time elapses, the status pin for the channel shows the inverted input signal. This diagnosis flag is not latched. Therefore, if the fault condition is removed, the status pins will indicate normal operation.

Unlike the status pins, when using the SPI interface and/or fault pin, diagnosis flags are latched in the diagnosis register of the SPI interface. In this case, diagnosis flags are cleared by the rising edge of the \overline{CS} signal after a successful SPI transmission.

Please see [Table 1](#) and [Figure 13](#) for details.

Table 1 Diagnostic Information

Operating Condition	Control Input	Power Output	Filter Time	Status Output	Fault Output	Channel Diagnosis Bits MSB, LSB	Channel Overtemp. Flag
Sleep Mode	x	off	–	L	H	– –	–
Normal Operation	L	off	–	L	H	H, H	L
	H	on	–	H	H	H, H	L
Short to ground	L	off	$t_{d(\text{fault})}$	H	L	L, L	L
	H	on	$t_{d(\text{fault})}$	L	L	L, H	L
Open load, Under current. ¹⁾	L	off	$t_{d(\text{fault})}$	H	L	L, H	L
	H	on	$t_{d(\text{fault})}$	L	L	L, H	L
Over load (current limit 1, current limitation) ¹⁾	H	on	$t_{d(\text{fault})}$	L	L	H, L	L
Over load (current limit 2, latching shutdown) ²⁾	H	off	$t_{d(\text{off})}$	L	L	H, L	L
Overtemp. (autorestart)	H	off ³⁾	–	L	L	H, L	H
Overtemp. (latching shutdown)	H	off ⁴⁾	–	L	L	H, L	H

1) Short to ground/open load/ under current /overload/short-to-supply - events shorter than min. time $t_{d(\text{fault})}$ will not be latched and not reported at the diagnosis pins.

2) Overload/short-to-supply - events shorter than min. time $t_{d(\text{off})}$ will not be latched and not reported at the diagnosis pins.

3) Off as long as overtemperature occurs, restart after cooling down.

4) Shutdown latch reset by falling input edge.

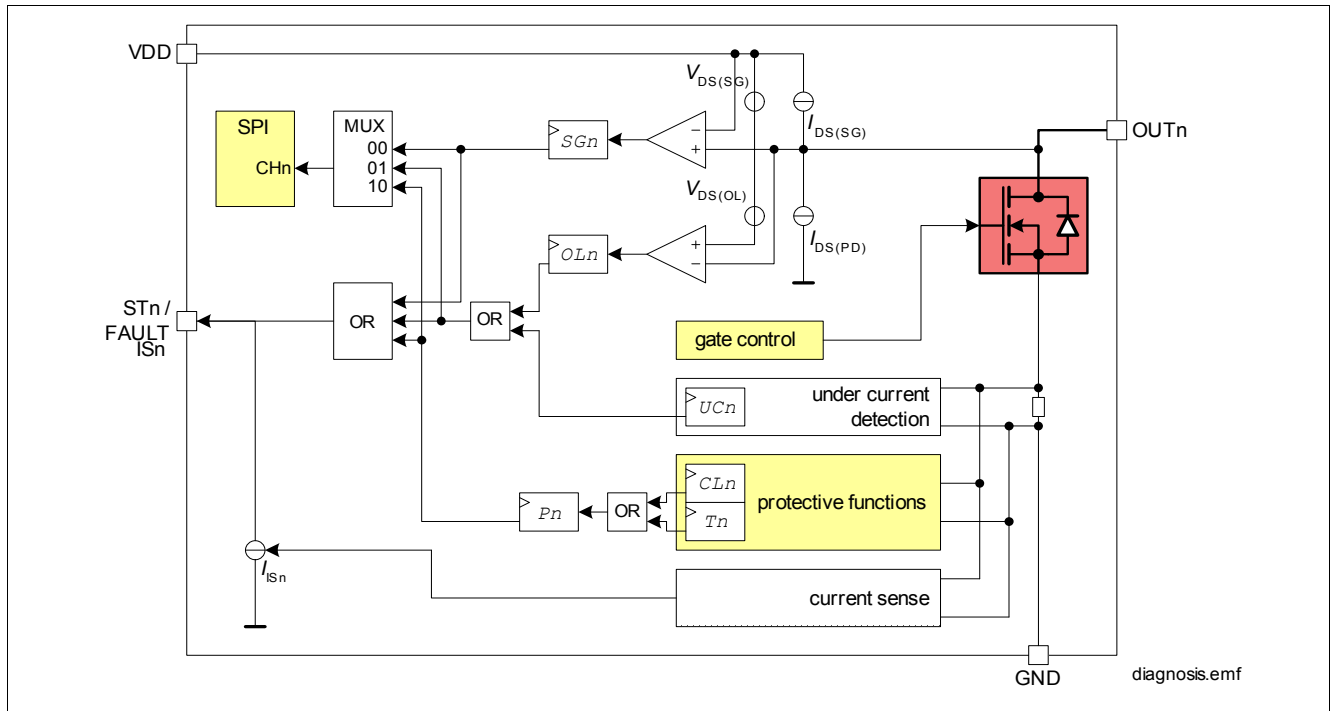

Figure 13 Block Diagram of Diagnostic Functions

Electrical Characteristics: Diagnostic Functions

$V_{DD} = 4.5\text{ V to }5.5\text{ V}$, $T_j = -40\text{ }^\circ\text{C to }+150\text{ }^\circ\text{C}$, (unless otherwise specified)
all voltages with respect to ground, positive current flowing into pin

Pos.	Parameter	Symbol	Limit Values			Unit	Conditions
			Min.	Typ.	Max.		
5.4.1	Open Load Detection Voltage (Channel OFF)	$V_{DS(OL)}$	$0.5 \times V_{DD}$	$0.6 \times V_{DD}$	$0.7 \times V_{DD}$	V	–
5.4.2	Output Pull-down Current (Channel OFF)	$I_{PD(OL)}$	25	50	100	μA	–
5.4.3	Fault Filtering Time	$t_{d(\text{fault})}$	50	100	200	μs	–
5.4.4	Overload switch off delay time (only current limit 2)	$T_{d(\text{off})}$	10 10	– –	50 150	μs	Slew rate 1 Slew rate 2
5.4.5	Short to Ground Detection Voltage	$V_{DS(SHG)}$	$0.3 \times V_{DD}$	$0.4 \times V_{DD}$	$0.5 \times V_{DD}$	V	–
5.4.6	Output Pull-up Current (Channel OFF)	$I_{PU(SHG)}$	-50	-100	-150	μA	–
5.4.7	Under Current Detection Threshold (Channel ON)	$I_{D(OL)}$	100	170	300	mA	–

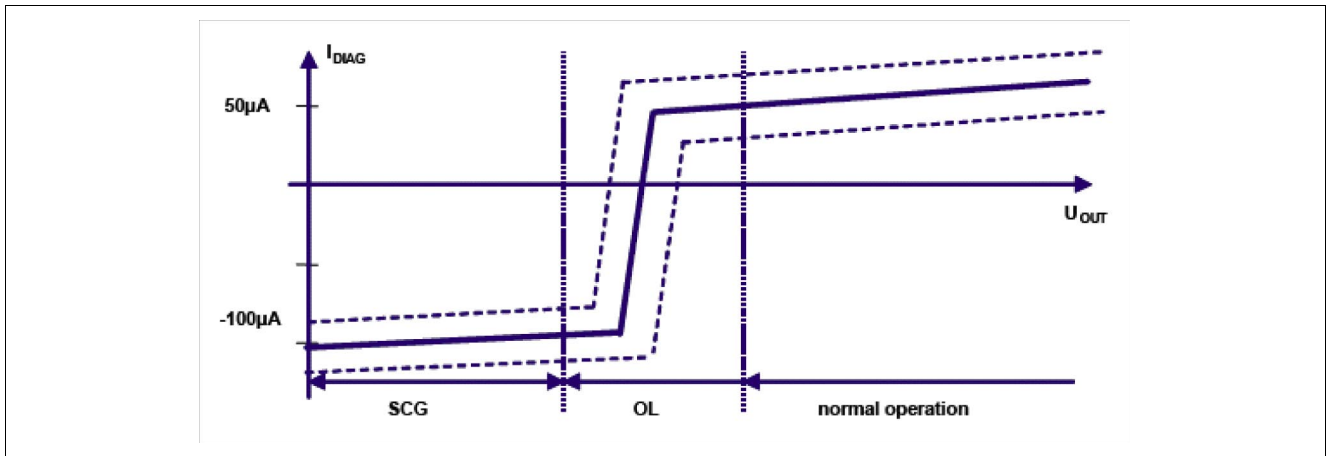

Figure 14 Open load (off) and Short to GND Diagnostics

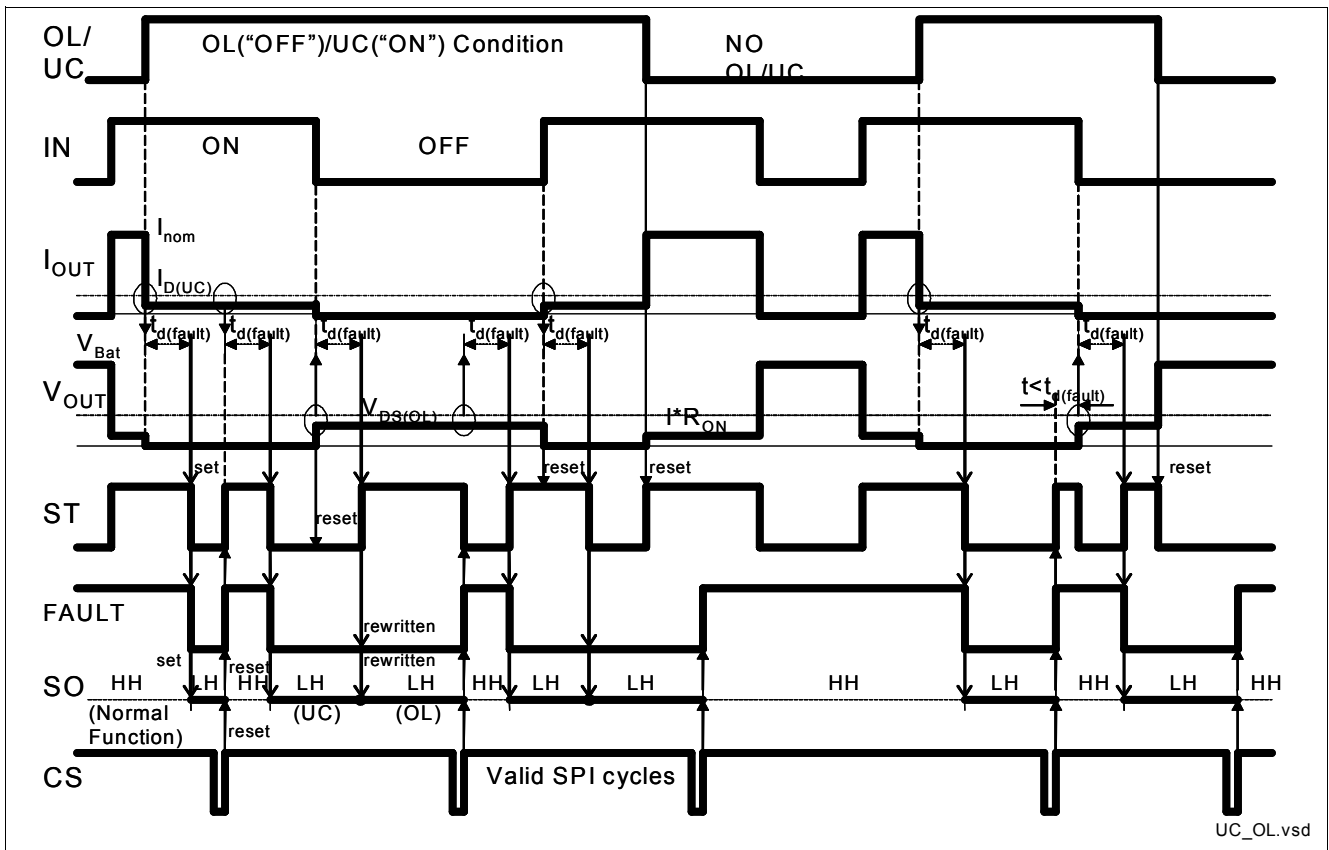

Figure 15 Diagnostic at "Open Load/Under Current" Condition

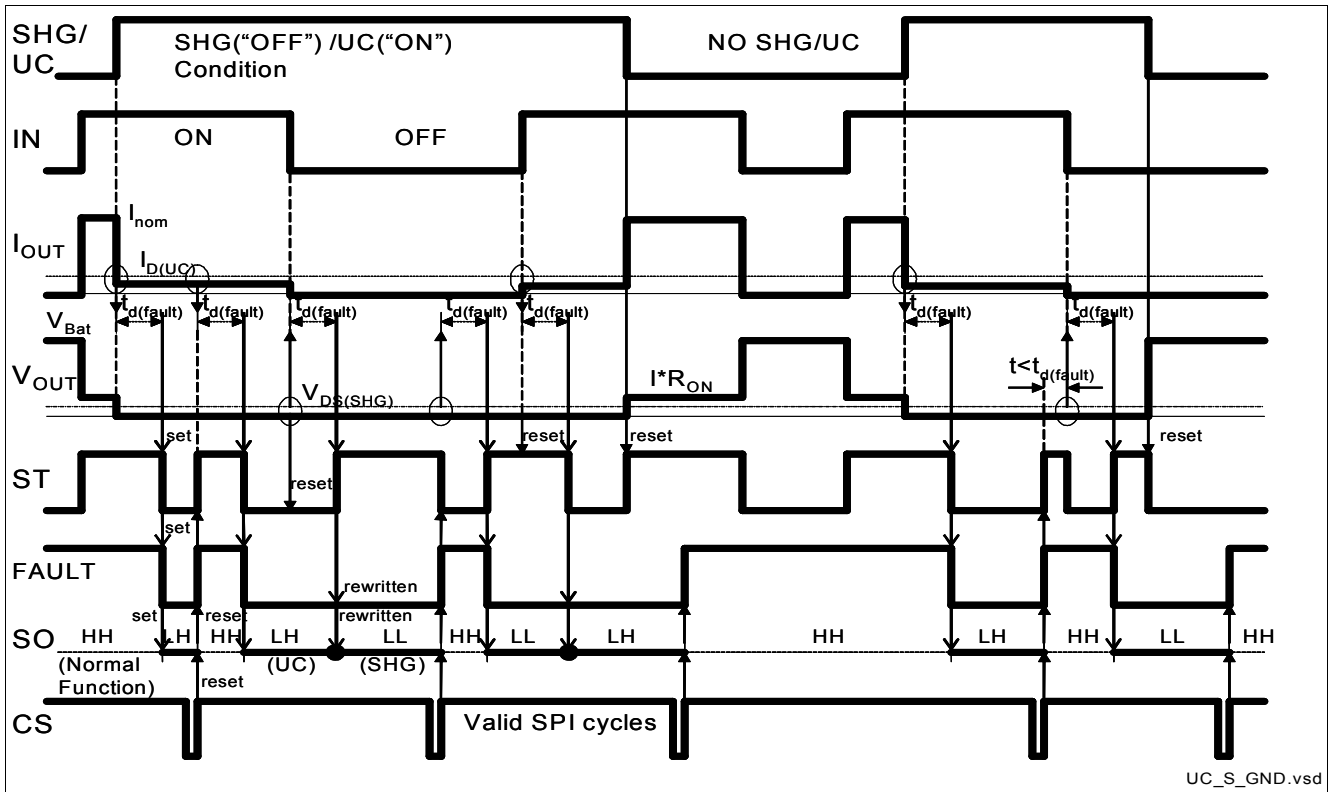

Figure 16 Diagnostic at "Short to GND/Under Current" Condition

5.5 Current Sense

The TLE8102SG includes an integrated current sense feature. If the device is programmed (via SPI) to use this feature, the current source I_{IS} of the current sense pin becomes active and generates a pull-down current proportional to the load current of the selected channel. An external pull-up resistor must be connected to the current sense pin to generate a voltage signal proportional to the load current of the selected channel. To achieve the specified accuracy for current sensing, the voltage V_{IS} at the current sense pin must always be greater than or equal to 2 V. The current source I_{IS} can also be programmed to generate a current proportional to the sum of the load current of both channels.

Electrical Characteristics: Current Sense

$V_{DD} = 4.5 \text{ V to } 5.5 \text{ V}$, $T_j = -40 \text{ }^\circ\text{C to } +150 \text{ }^\circ\text{C}$, (unless otherwise specified)

all voltages with respect to ground, positive current flowing into pin

Pos.	Parameter	Symbol	Limit Values			Unit	Conditions
			Min.	Typ.	Max.		
5.5.1	Current Sense Precision (single channel) ¹⁾ I_{FB}/I_{OUT}	P_{IS}	0.50 0.80 0.90 0.93 0.94 0.95	1.00	1.50 1.20 1.10 1.07 1.06 1.05	mA/A	$V_{DD} = 5 \text{ V}$, $U_{CO1} \geq 2 \text{ V}$ $I_D = 100 \text{ mA}$, $I_D = 200 \text{ mA}$, $I_D = 500 \text{ mA}$, $I_D = 1 \text{ A}$, $I_D = 3 \text{ A}$, $I_D = 5 \text{ A}$,
5.5.2	Current Sense Temperature Deviation ^{1) 2) 3)} at	I_{Stemp}	- 25 -10 -4 -3 -3 -3	$P_{IS(25^\circ\text{C}, ID)}$	+25 +10 +4 +3 +3 +3	%	$V_{DD} = 5 \text{ V}$, $U_{CO1} \geq 2 \text{ V}$ $I_D = 100 \text{ mA}$, $I_D = 200 \text{ mA}$, $I_D = 500 \text{ mA}$, $I_D = 1 \text{ A}$, $I_D = 3 \text{ A}$, $I_D = 5 \text{ A}$,
5.5.3	Current Sense Settle time ²⁾	t_{IS}	–	–	4	μs	$U_{CO1} \geq 2 \text{ V}$, $R_{sense} = 2.5 \text{ k}\Omega$ ($I_{Dmax} = 1 \text{ A}$)
5.5.4	Current Sense Settle time ²⁾	t_{IS}	–	–	2	μs	$U_{CO1} \geq 2 \text{ V}$, $R_{sense} = 500 \Omega$ ($I_{Dmax} = 5 \text{ A}$)
5.5.5	Output Tri-state Leakage Current	I_{SOIkG}	-10	0	10	μA	$\overline{CS} = H$, $0 \leq V_{SO} \leq V_{DD}$
5.5.6	FAULT Output Low Voltage	V_{FAULTL}	–	–	0.4	V	$I_{FAULT} = 1.6 \text{ mA}$
5.5.7	Status Output Low Voltage	V_{ST}	–	–	0.4	V	$I_{ST} = 1.6 \text{ mA}$

1) If the summed current is sensed the tolerances of the single channels are added.

2) Not subject to production test, specified by design.

3) Temperature Variation of one single device.

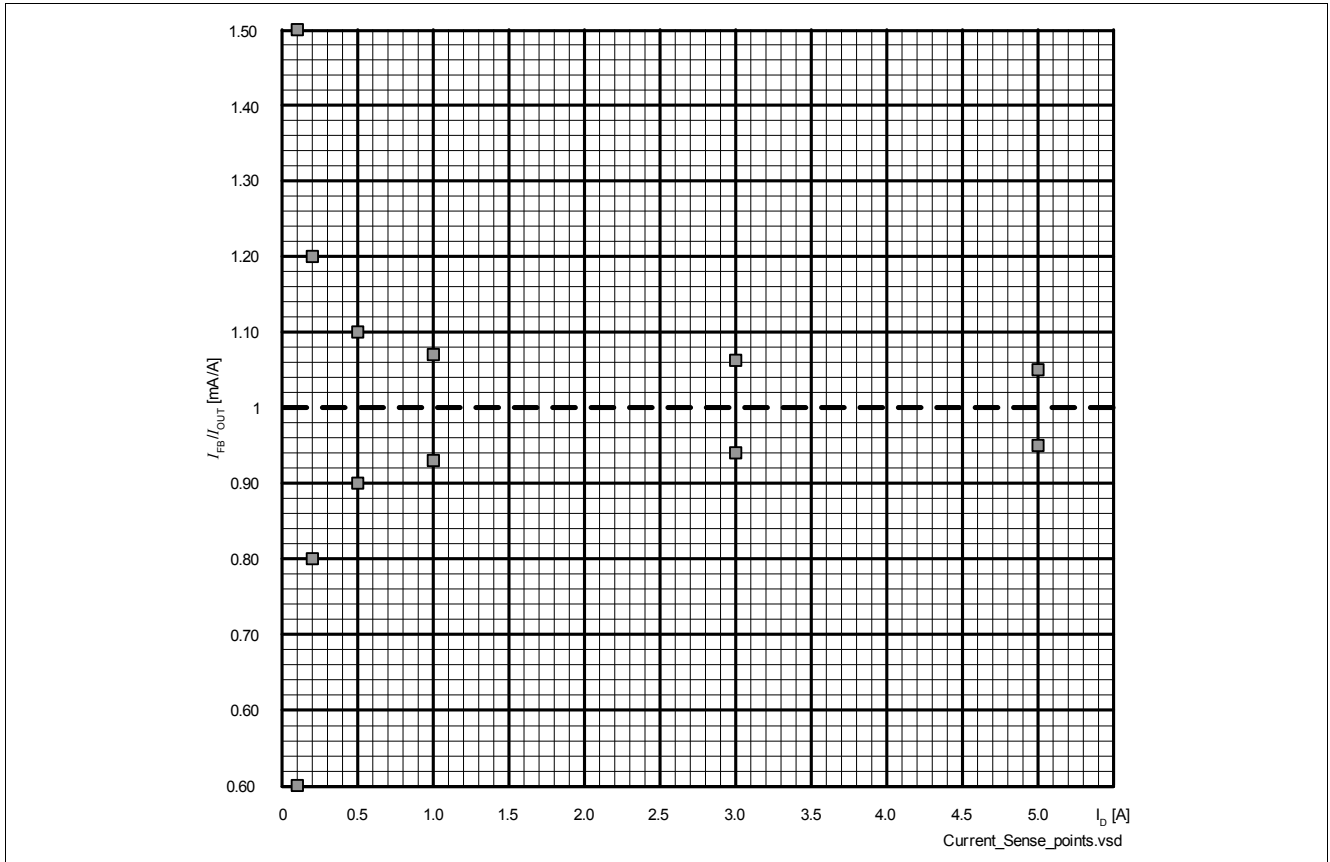

Figure 17 Current Sense Precision

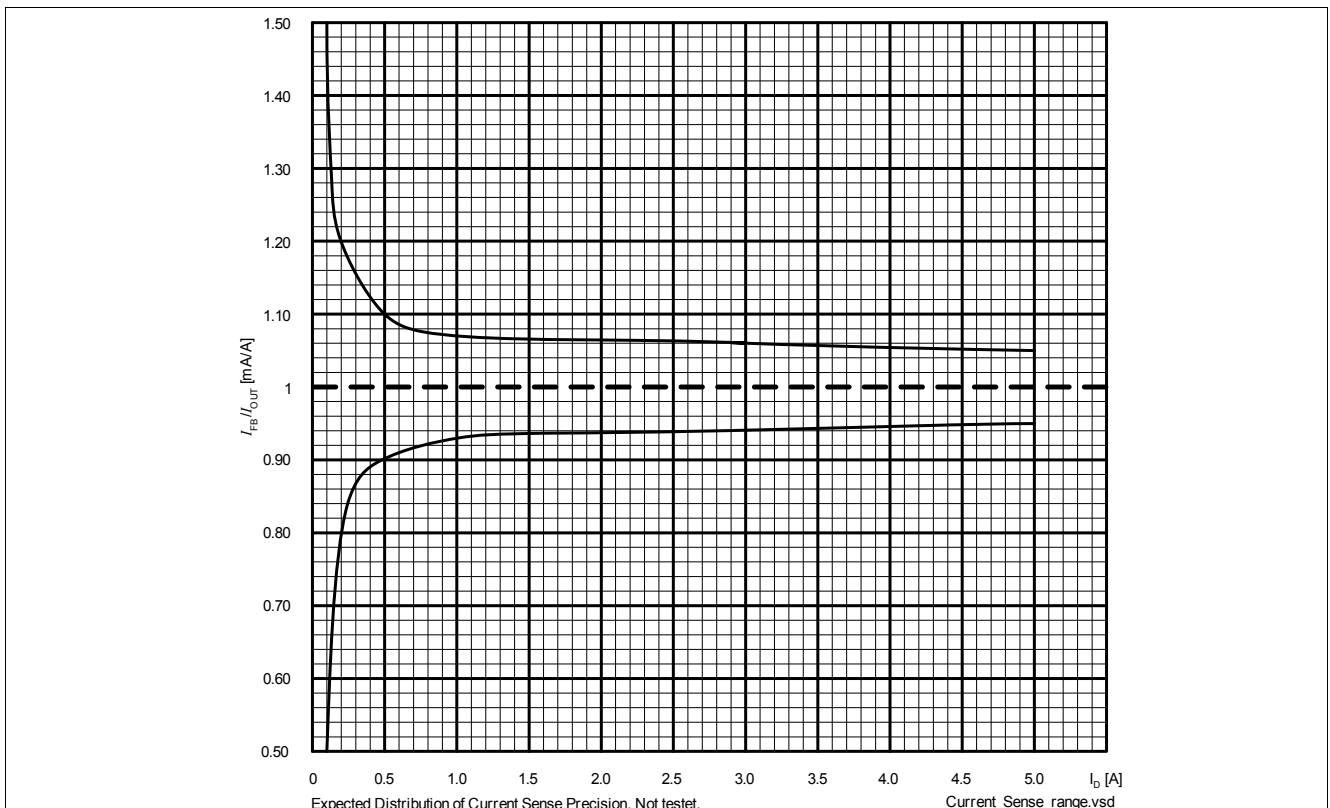

Figure 18 Current Sense Precision - range of expected distribution.

5.6 SPI Interface

The diagnosis and control interface is based on a serial peripheral interface (SPI).

The SPI is a full duplex synchronous serial slave interface, which uses four lines: SO, SI, SCLK and \overline{CS} . Data is transferred by the lines SI and SO at the data rate given by SCLK. The falling edge of \overline{CS} indicates the beginning of a data access. Data is sampled in on line SI at the falling edge of SCLK and shifted out on line SO at the rising edge of SCLK. Each access must be terminated by a rising edge of \overline{CS} . The interface provides daisy chain capability.

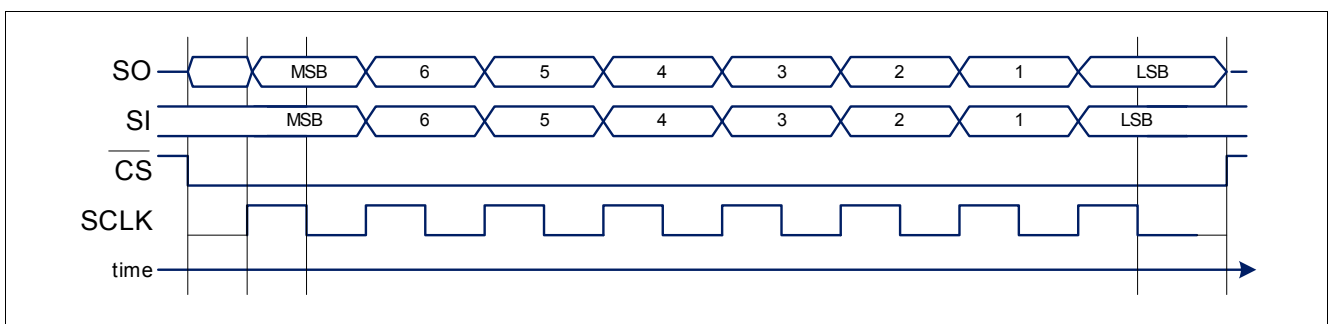

Figure 19 Serial Peripheral Interface

The SPI protocol is described in [Section 6](#). All registers are reset to default values after power-on reset or if the chip is programmed via SPI to enter sleep mode.

5.6.1 SPI Signal Description

\overline{CS} - Chip Select: The system micro controller selects the TLE8102SG by means of the \overline{CS} pin. Whenever the pin is in low state, data transfer can take place. When \overline{CS} is in high state, any signals at the SCLK and SI pins are ignored and SO is forced into a high impedance state.

\overline{CS} High to Low transition: 

- The diagnosis information is transferred into the shift register.

\overline{CS} Low to High transition: 

- Command decoding is only done after the falling edge of \overline{CS} if the command is valid.
- Data from shift register is transferred into the input matrix register.
- The diagnosis flags are cleared.

SCLK - Serial Clock: This input pin clocks the internal shift register. The serial input (SI) transfers data into the shift register on the falling edge of SCLK while the serial output (SO) shifts diagnostic information out on the rising edge of the serial clock. It is essential that the SCLK pin is in low state whenever chip select \overline{CS} makes any transition.

SI - Serial Input: Serial input data bits are shifted in at this pin, the most significant bit first. SI information is read on the falling edge of SCLK. The 8 bit input data consist of two parts (control and data). Please refer to [Section 6](#) for further information.

SO - Serial Output: Data is shifted out serially at this pin, the most significant bit first. SO is in high impedance state until the \overline{CS} pin goes to low state. New data will appear at the SO pin following the rising edge of SCLK. Please refer to [Section 6](#) for further information.

5.6.2 Daisy Chain Capability

The SPI of TLE8102SG is daisy chain capable. In this configuration several devices are activated by the same signal \overline{CS} . The SI line of one device is connected with the SO line of another device (see [Figure 20](#)), which builds a chain. The ends of the chain are connected with the output and input of the master device, SO and SI respectively. The master device provides the master clock SCLK, which is connected to the SCLK line of each device in the chain.

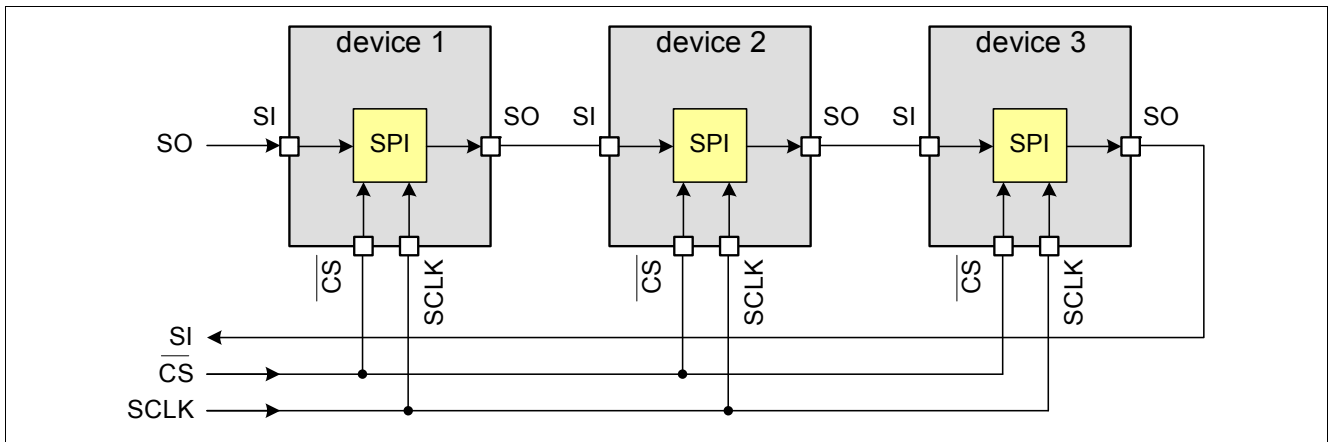

Figure 20 Daisy Chain Configuration

In the SPI block of each device, there is one shift register where one bit from SI line is shifted in each SCLK. The bit shifted out can be seen at SO. After 8 SCLK cycles, the data transfer for one device has been finished. In single chip configuration, the \overline{CS} line must go high to make the device accept the transferred data. In daisy chain configuration the data shifted out at device 1 has been shifted in to device 2. When using three TLE8102SG devices in daisy chain, three times 8 bits have to be shifted through the devices. After that, the \overline{CS} line must go high (see [Figure 21](#)).

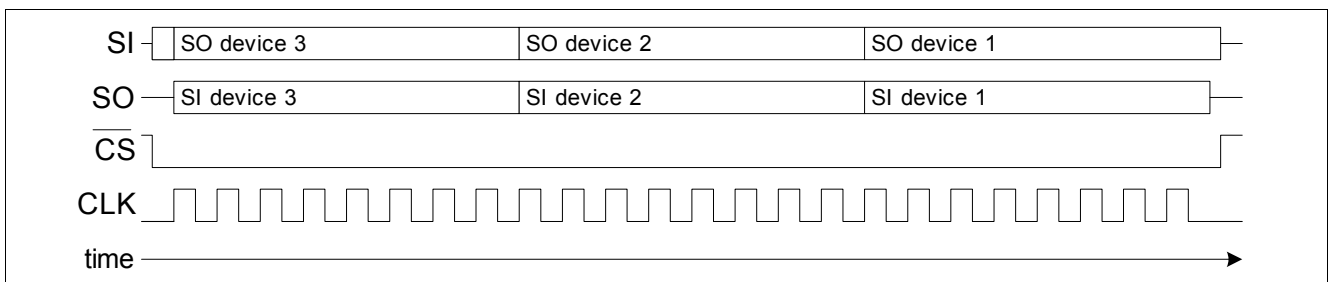

Figure 21 Data Transfer in Daisy Chain Configuration

Electrical Characteristics: SPI Interface

$V_{DD} = 4.5\text{ V to }5.5\text{ V}$, $T_j = -40\text{ }^\circ\text{C to }+150\text{ }^\circ\text{C}$, (unless otherwise specified)
all voltages with respect to ground, positive current flowing into pin

Pos.	Parameter	Symbol	Limit Values			Unit	Conditions
			Min.	Typ.	Max.		
5.6.1	Input Pull-down Current (SI, SCLK)	$I_{IN(SI,SCLK)}$	10	20	50	μA	–
5.6.2	Input Pull-up Current (\overline{CS})	$I_{IN(\overline{CS})}$	10	20	50	μA	–

Electrical Characteristics: SPI Interface (cont'd)

$V_{DD} = 4.5\text{ V to }5.5\text{ V}$, $T_j = -40\text{ °C to }+150\text{ °C}$, (unless otherwise specified)
all voltages with respect to ground, positive current flowing into pin

Pos.	Parameter	Symbol	Limit Values			Unit	Conditions
			Min.	Typ.	Max.		
5.6.3	SO High State Output Voltage	V_{SOH}	$V_{DD} - 0.4$	–	–	V	$I_{SOH} = 2\text{ mA}$
5.6.4	SO Low State Output Voltage	V_{SOL}	–	–	0.4	V	$I_{SOL} = 2.5\text{ mA}$
5.6.5	Serial Clock Frequency (depending on SO load)	f_{SCK}	DC	–	5	MHz	–
5.6.6	Serial Clock Period ($1/f_{sck}$)	$t_{p(SCK)}$	200	–	–	ns	–
5.6.7	Serial Clock High Time	t_{SCKH}	80	–	–	ns	–
5.6.8	Serial Clock Low Time	t_{SCKL}	80	–	–	ns	–
5.6.9	Enable Lead Time (falling edge of \overline{CS} to rising edge of SCLK)	t_{lead}	200	–	–	ns	–
5.6.10	Enable Lag Time (falling edge of SCLK to rising edge of \overline{CS})	t_{lag}	200	–	–	ns	–
5.6.11	Data Setup Time (required time SI to falling of SCLK)	t_{SU}	20	–	–	ns	–
5.6.12	Data Hold Time (falling edge of SCLK to SI)	t_H	20	–	–	ns	–
5.6.13	Disable Time ¹⁾	t_{DIS}	–	–	150	ns	–
5.6.14	Transfer Delay Time ²⁾ (\overline{CS} high time between two accesses)	t_{dt}	300	–	–	ns	–
5.6.15	Data Valid Time	t_{valid}	–	–	120 150	ns	$C_L = 50\text{ pF}^{1)}$ $C_L = 100\text{ pF}^{1)}$

1) Not subject to production test, specified by design.

2) This time is necessary between two write accesses. To get the correct diagnostic information, the transfer delay time has to be extended to the maximum fault delay time $t_{d(fault)max} = 200\text{ }\mu\text{s}$.

5.7 Timing Diagrams

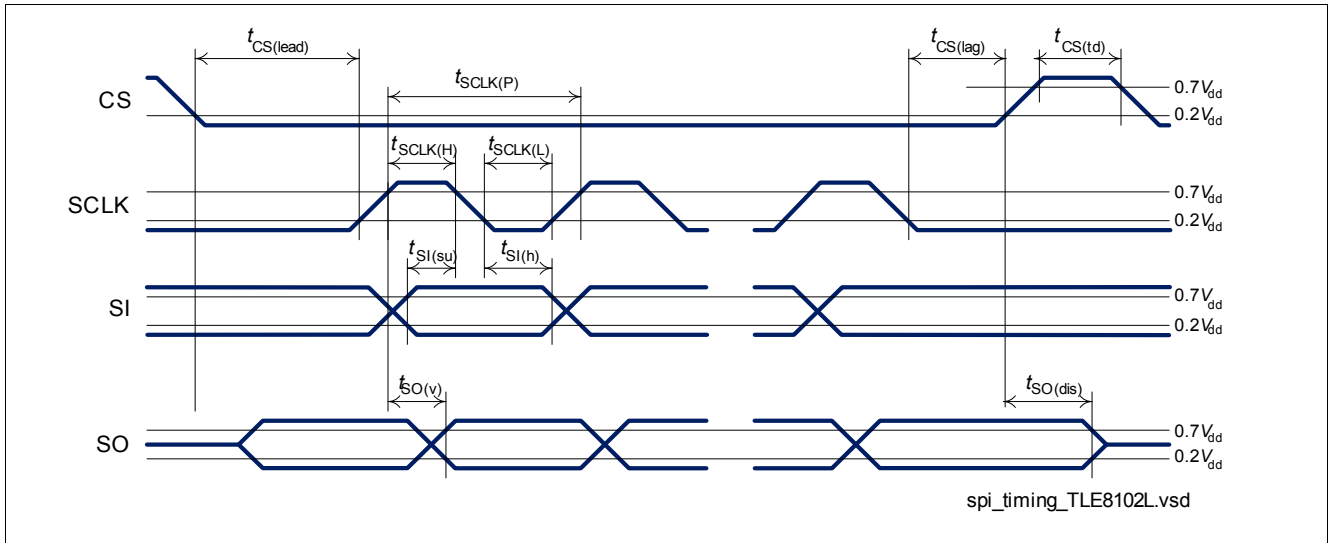

Figure 22 Serial Interface Timing Diagram

6 SPI Control

The SPI protocol of the TLE8102SG provides two types of registers: control and diagnosis. After power-on reset, all register bits are set to default values.

Serial Input

Default Value: xxxx_H

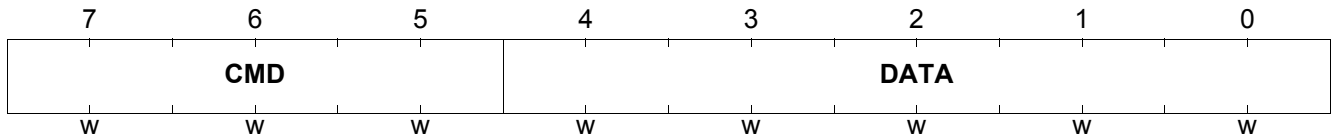

Field	Bits	Type	Description
CMD	7:5	w	<p>Command</p> <p>001 Diagnosis only: The requested data is shifted out at SO. The data bits are ignored.</p> <p>010 Output Configure: Configures the behavior of the power outputs.</p> <p>011 I/O Configure: Configures the behavior of the I/O ports.</p> <p>100 Reset Registers: Resets all internal registers to their reset values. The data bits are ignored.</p> <p>101 Sleep Mode: Activates the low quiescent mode. In sleep mode, only the command “wake up” will be accepted. Other commands will not be accepted. Wake up can be performed by sending the wake up command or by performing an undervoltage reset. The data bits are ignored.</p> <p>110 Wake up: Deactivates the sleep mode. After time delay t_{wake}, the device becomes fully functional. The data bits are ignored.</p> <p>111 Channels ON/OFF: Turns on/off the power outputs (if configured for serial control)</p> <p>000 No command: Not accepted as a valid command and the data bits will be ignored. Additionally, the diagnosis register will not be reset.</p>
DATA	4:0	w	<p>Data</p> <p>Data written to register selected by CMD</p>

Output Configure

Default Value: 00_H

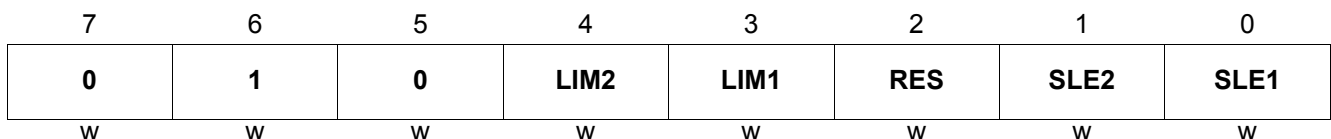

Field	Bits	Type	Description
LIM _n	n+2	w	<p>Over load current limitation channel n</p> <p>0 Current limit 2 is active ($I_{Dn(lim2)}$)</p> <p>1 Current limit 1 is active ($I_{Dn(lim1)}$)</p>

Field	Bits	Type	Description
RES	2	w	Over temperature behavior of all channels 0 Automatic autorestart of a channel after cooling down 1 Latching shutdown at over temperature
SLE _n	n-1	w	Slew rate of channel n 0 Slew rate 1 1 Slew rate 2

I/O Configure
Default Value: 00_H

7	6	5	4	3	2	1	0
0	1	1	DIA	BOL		SENS	
w	w	w	w	w	w	w	w

Field	Bits	Type	Description
DIA	4	w	Status / SPI of diagnostic information 0 Diagnosis output with one status output per channel (ST1, ST2) 1 Diagnosis output with SPI interface (SO) and fault pin / current sense
BOL	3:2	w	Parallel / Serial control of all channels 00 With parallel input only (IN1, IN2) 01 With logic OR operation of IN _n and data bits 10 With logic AND operation of IN _n and data bits 11 With SPI interface only
SENS	1:0	w	Function of fault / current sense output 00 General fault pin 01 Current sense output of channel 1 (I_{IS1}) 10 Current sense output of channel 2 (I_{IS2}) 11 Current sense output of channel 1+2 ($I_{IS1}+I_{IS2}$)

Channels ON/OFF
Default Value: 00_H

7	6	5	4	3	2	1	0
1	1	1	CTRL2	CTRL1	X	X	X
w	w	w	w	w	w	w	w

Field	Bits	Type	Description
CTRL _n	n+2	w	SPI control of channel n (CHn_{IN}) 0 Output off 1 Output on

Serial Output (Standard Diagnosis)
Default Value: FF_H

7	6	5	4	3	2	1	0
-	-	CH2 (CH2 ₁ , CH2 ₀)		CH1 (CH1 ₁ , CH1 ₀)		Channel Over temp.	IC Over temp.
r	r	r	r	r	r	r	r

Field	Bits	Type	Description
CHn	2n+1: 2n	r	Standard Diagnosis for Channel n 00 Short circuit to ground 01 Open load / Under current 10 Over load / over temperature 11 Normal operation
Channel over temp.	1	r	Channel Over Temperature Flag 0 No channel has an over temperature condition 1 One or both channels has an over temperature condition
IC Over temp.	0	r	Device Over Temperature Flag 0 IC temperature is below IC over temperature warning threshold T_w 1 IC temperature has exceeded IC over temperature warning threshold T_w

7 Application Description

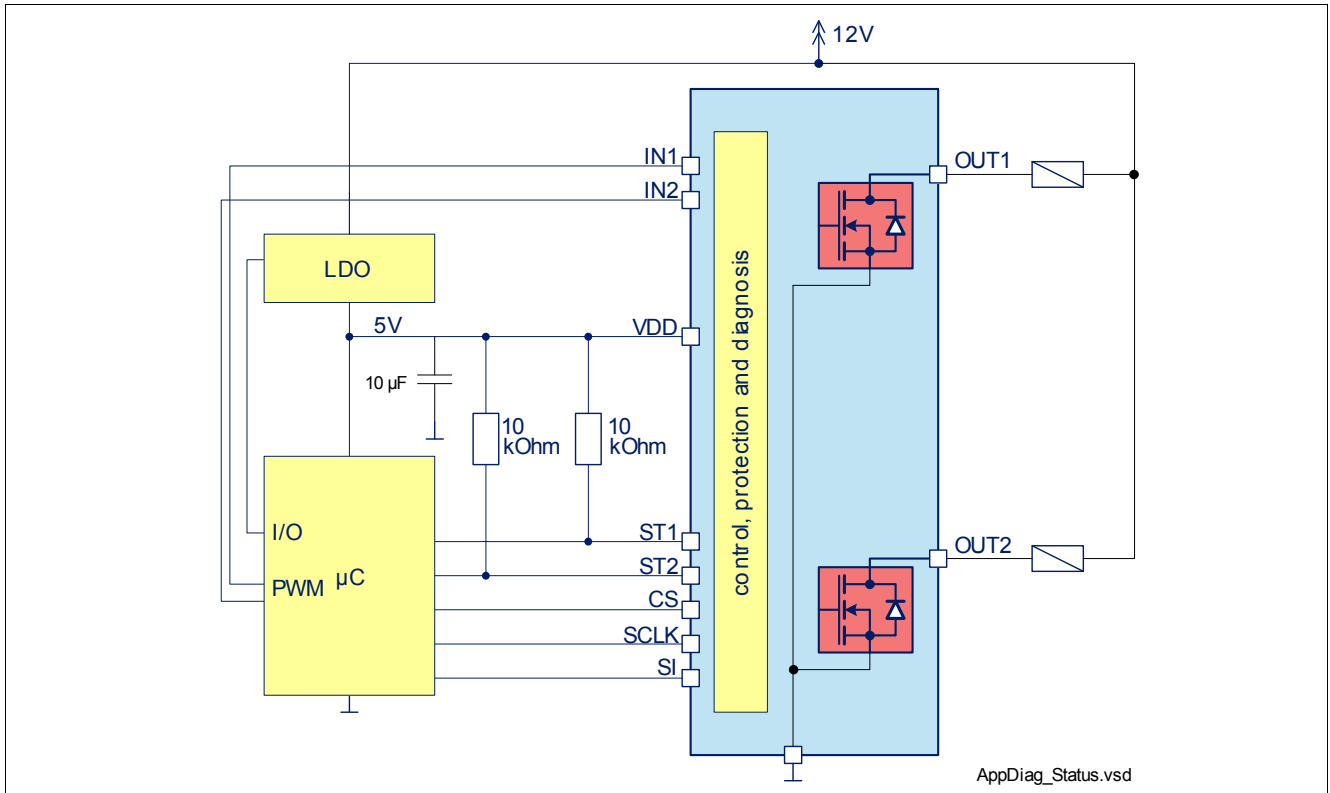

Figure 23 Application Circuit using Status Outputs only

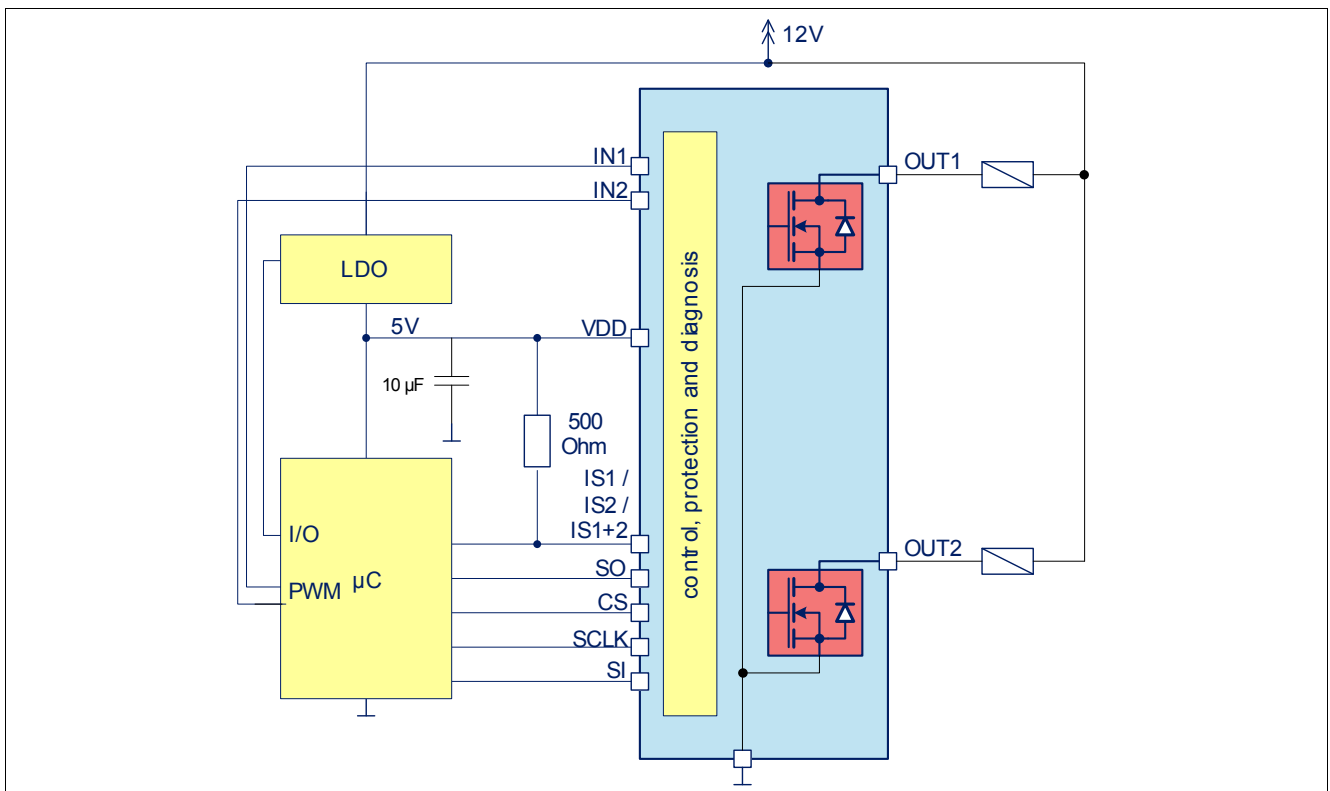

Figure 24 Application Circuit using SPI and Current Sense Output

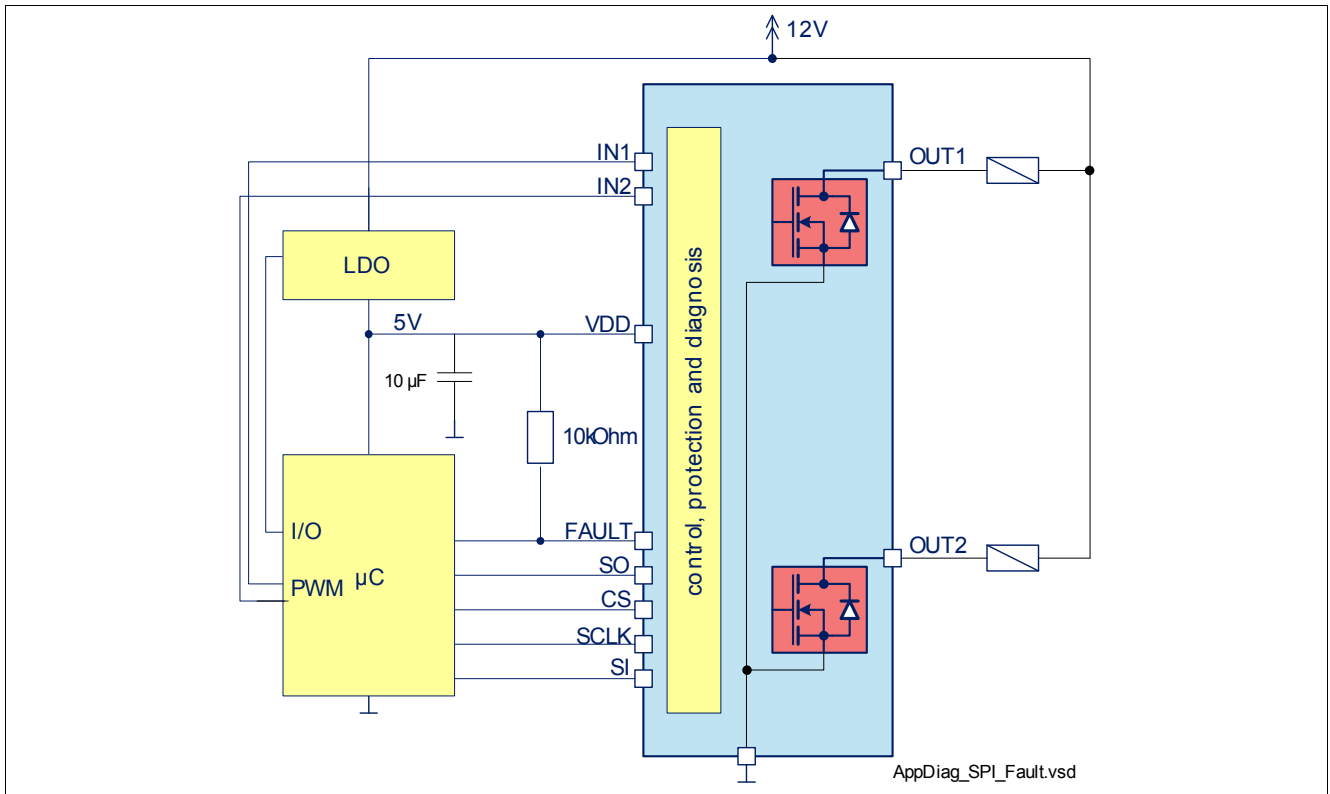

Figure 25 Application Circuit using SPI and Fault Flag

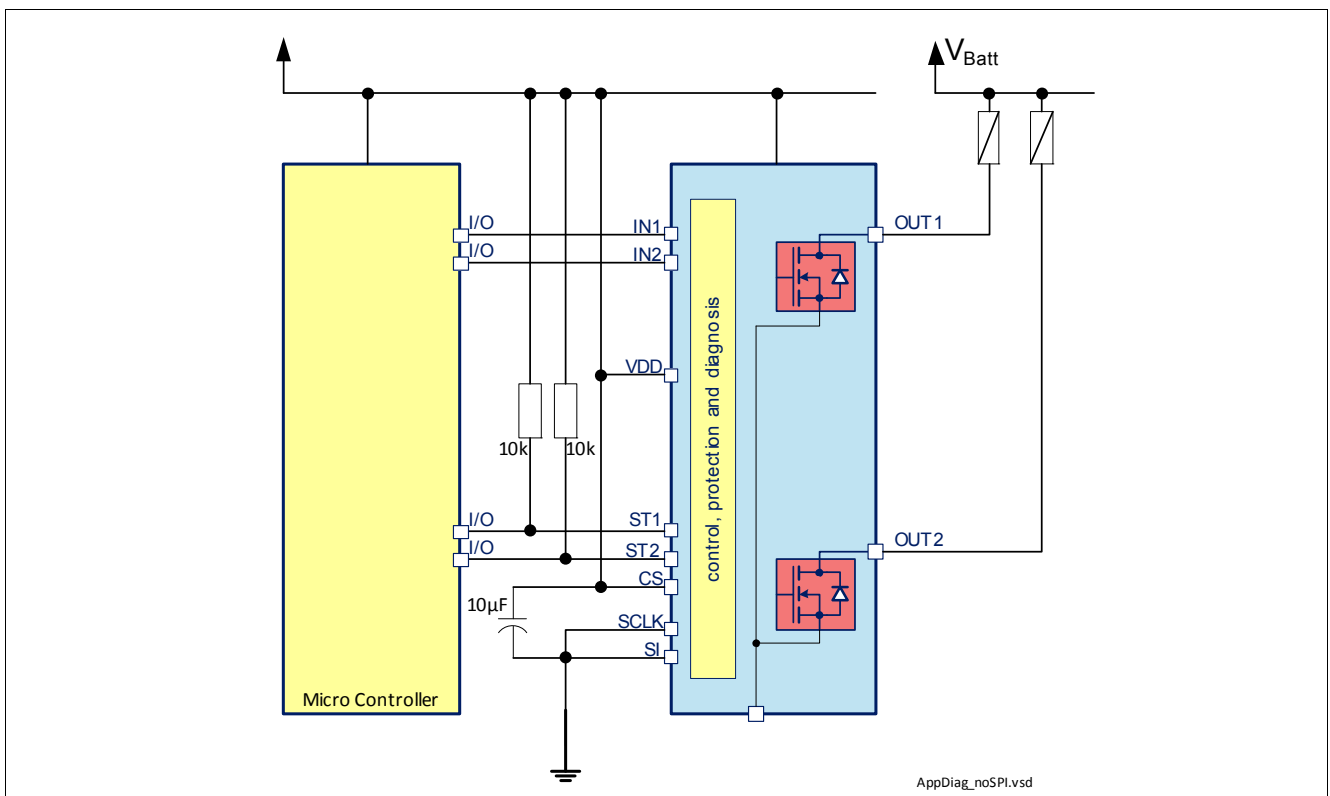

Figure 26 Application Circuit using parallel Inputs and Status Outputs, no SPI.

8 Package Outlines

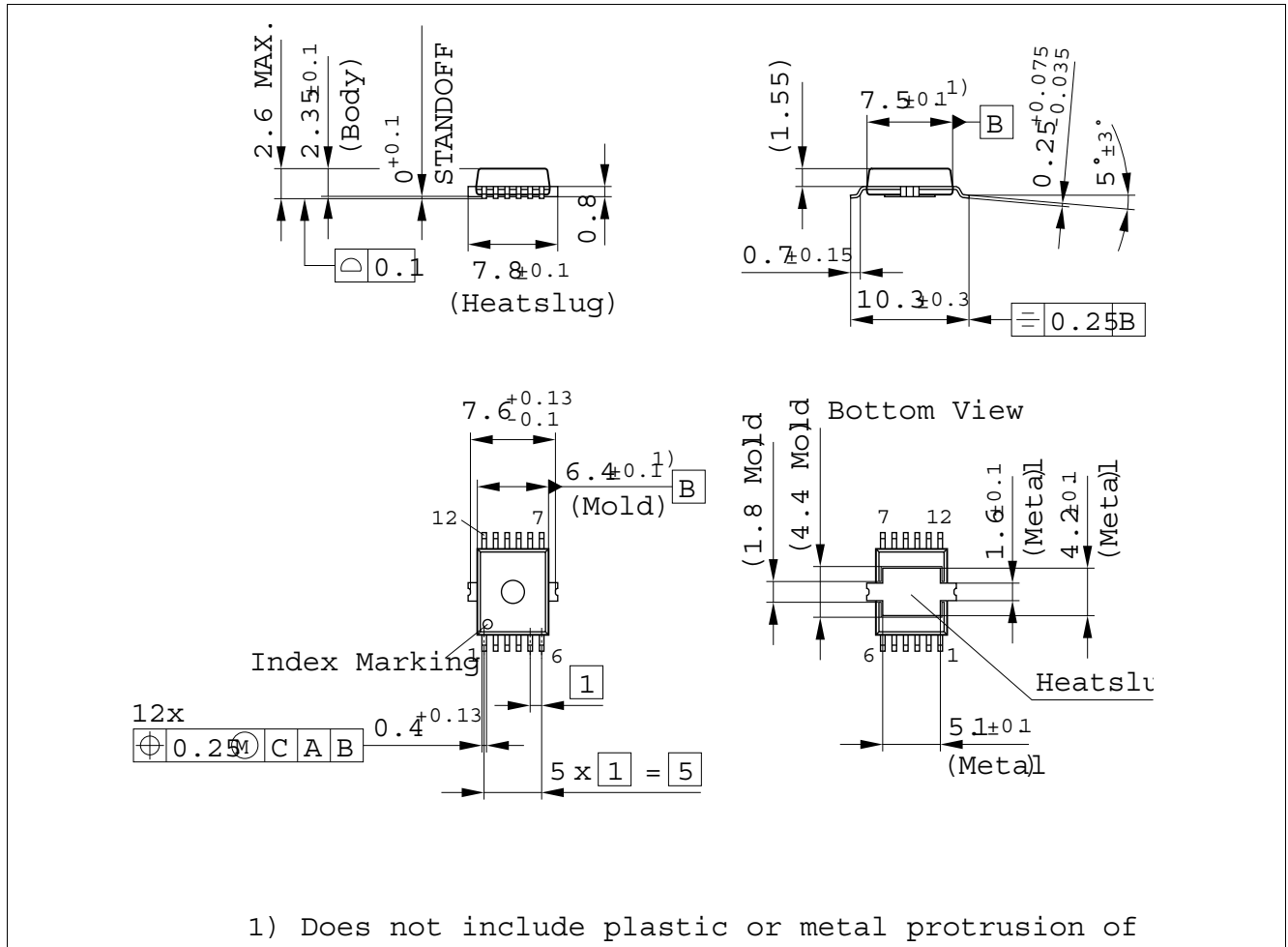

Figure 27 PG-DSO-12-11 (Plastic Dual Small Outline Package) - Green Product.

Green Product

To meet the world-wide customer requirements for environmentally friendly products and to be compliant with government regulations the device is available as a green product. Green products are RoHS-Compliant (i.e. Pb-free finish on leads and suitable for Pb-free soldering according to IPC/JEDEC J-STD-020).

9 Revision History

Version	Date	Changes
2012-08-17: Version 1.5: Data Sheet:		
V1.5	2012-08-17	Figure 26 corrected. No Functional Change
08-05-08: Version 1.4: Data Sheet:		
V1.4	08-05-08	Table 1 corrected. Functionality not changed.
V1.4	08-05-08	Figure 14 corrected. No functional change.
08-04-24: Version 1.3: Data Sheet:		
V1.3	08-04-24	Data Sheet released

Edition 2012-08-17

**Published by
Infineon Technologies AG
81726 München, Germany**

**© Infineon Technologies AG 2012.
All Rights Reserved.**

Legal Disclaimer

The information given in this document shall in no event be regarded as a guarantee of conditions or characteristics ("Beschaffenhheitsgarantie"). With respect to any examples or hints given herein, any typical values stated herein and/or any information regarding the application of the device, Infineon Technologies hereby disclaims any and all warranties and liabilities of any kind, including without limitation warranties of non-infringement of intellectual property rights of any third party.

Information

For further information on technology, delivery terms and conditions and prices please contact your nearest Infineon Technologies Office (www.infineon.com).

Warnings

Due to technical requirements components may contain dangerous substances. For information on the types in question please contact your nearest Infineon Technologies Office.

Infineon Technologies Components may only be used in life-support devices or systems with the express written approval of Infineon Technologies, if a failure of such components can reasonably be expected to cause the failure of that life-support device or system, or to affect the safety or effectiveness of that device or system. Life support devices or systems are intended to be implanted in the human body, or to support and/or maintain and sustain and/or protect human life. If they fail, it is reasonable to assume that the health of the user or other persons may be endangered.

AMEYA360

Components Supply Platform

Authorized Distribution Brand :



Website :

Welcome to visit www.ameya360.com

Contact Us :

➤ Address :

401 Building No.5, JiuGe Business Center, Lane 2301, Yishan Rd
Minhang District, Shanghai , China

➤ Sales :

Direct +86 (21) 6401-6692

Email amall@ameya360.com

QQ 800077892

Skype [ameyasales1](#) [ameyasales2](#)

➤ Customer Service :

Email service@ameya360.com

➤ Partnership :

Tel +86 (21) 64016692-8333

Email mkt@ameya360.com