

2mm Pitch, Multi functional Connector System. (Floating [Board-to-Board], Swing-Lock [Wire-to-Board], Short Pin)

DF59 Series



■ Features

1. Floating Structure (Board-to-Board)

The Board-to-Board connector can be used to connect multiple boards together in a co-planar arrangement and features a “Stress free contact” that floats $\pm 0.5\text{mm}$ in the X, Y and Z dimensions.

2. Swing Lock Structure (Wire-to-Board)

The DF59 features a “swing-lock” mechanism that employs both a positive and friction lock. This helps to prevent the cable assembly from unmating by severe wiring and mechanical stress.

3. Short-Circuit Pin Connector

The Short-Circuit Pin connector allows the termination of an open circuit. Typically used at the end of a series of connected circuit boards.

4. Multi Function Design

The DF59 has the ability to function as either a Board-to-Wire or Board-to-Board System. The PCB mounted receptacle is designed to mate with the B-to-W, B-to-B, and Short Circuit Pin connectors. This multi function ability allows versatility while keeping connectors to a minimum.

5. Performance and Space Savings

The DF59 series offers high performance in a compact, space saving design; featuring a 2mm pitch and coupled with a mated height of only 2.48mm with AWG#22 cable. The single position floating plugs DF59S and DF59SN are specifically designed to save space, and can be mounted in high density applications.

6. Contact Design

The terminal design features two points contact to ensure a highly reliable connection.

7. High Operating Temperature

DF59's are rated at temperatures up to 105 °C.

8. Common Applicator

Crimping can be performed using the applicator (AP105-DF11-22S) for the existing series DF11-22S C F(A), by replacing the die with the one for DF59 series.

* For crimping quality standards and crimping conditions, crimping needs to be performed in accordance with the specific conditions of DF59-22PCFA.

◆ Floating Structure in Three Axial Directions (Board-to-Board Structure)



DF59 floating amount $\pm 0.5\text{mm}$ (X, Y, Z directions)

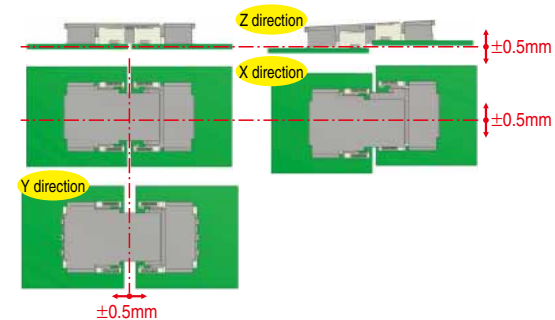

DF59S/SN floating amount

$\pm 0.5\text{mm}$ (X, Y direction), $\pm 0.2\text{mm}$ (Z direction)

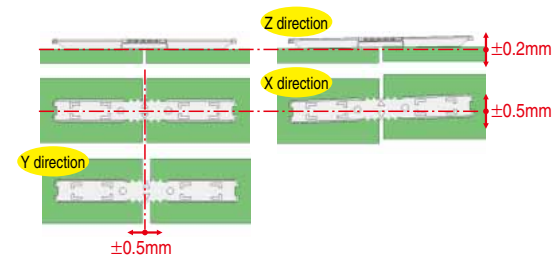

Fig.1

◆ Swing-Lock Structure (Board-to-Wire Structure)

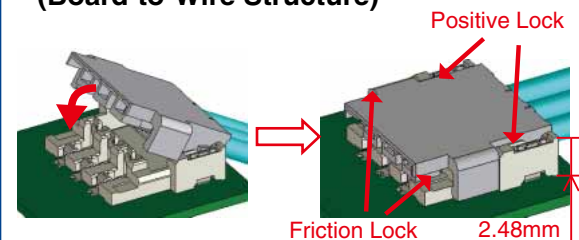

Fig.2

◆ Short Pin Connector

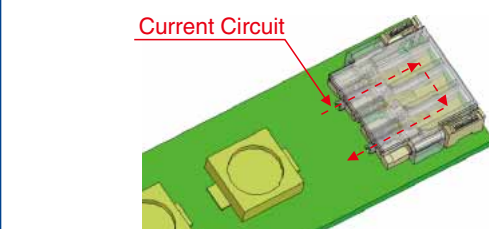

Fig.3

Product Specifications

| | | | | | |
|---------|----------------|---|---|---------------------|----------------------|
| Ratings | Current rating | 3A | Operating Temperature Operating Humidity Range | -35-105°C 20-80% | (Note 1) |
| | Voltage rating | AC/DC 230V AC/DC 350V (Without the central contact) | Storage Temperature Range Storage Humidity Range | -10-60°C 40-70% | (Note 2) (Note 2) |

| Items | Specifications | Conditions |
|---------------------------------|---|--|
| 1. Insulation resistance | Over 1000MΩ | Measured at DC 500V |
| 2. Withstanding voltage | No flashover or breakdown | AC650V / minute. |
| 3. Contact resistance | 50mΩ max. (DF59-*P-2FC/SP, DF59S/SN-1P-FC) 30mΩ max. (DF59-*P-2C) | Under 6V DC, must be Measured by 100mA (DC or 1000Hz) |
| 4. Vibration | No electrical discontinuity over 1μs. | Frequency 10-55Hz, single amplitude 0.75mm, 3 directions, 10 cycles each |
| 5. Shock | No electrical discontinuity over 1μs. | Acceleration 490 m/s ² , 11ms; duration, sine half-wave 3 cycles in each of the 3 axis. |
| 6. Humidity | <ul style="list-style-type: none"> ■ Contact resistance 50mΩ max. (DF59-*P-2FC/SP, DF59S/SN-1P-FC) 30mΩ max. (DF59-*P-2C) ■ Insulation resistance 1000MΩ min. | Temperature 40 ± 2°C, humidity 90-95%, left for 96 hours |
| 7. Temperature cycle | <ul style="list-style-type: none"> ■ Contact resistance 50mΩ max. (DF59-*P-2FC/SP, DF59S/SN-1P-FC) 30mΩ max. (DF59-*P-2C) ■ Insulation resistance 1000MΩ min. | (-55°C: 30 min. → 5-35°C: 2-3 min. → 85°C: 30 min. → 5-35°C: 2-3 min.) 5 cycles |
| 8. Operating Life | <ul style="list-style-type: none"> ■ Contact resistance 50mΩ max. (DF59-*P-2FC/SP, DF59S/SN-1P-FC) 30mΩ max. (DF59-*P-2C) | <ul style="list-style-type: none"> ■ Number of insertion and withdrawal force 30 times (DF59-*P-2FC/C) 10 times (DF59-*P-2SP, DF59S/SN-1P-FC) |
| 9. Resistance to soldering heat | No solubility of resin which affect the item's performance. | Reflow: Depends on recommended temperature profile. Hand soldering: Soldering iron temperature 350 ± 10°C, 3 sec. |

(Note 1) Including temperature rise caused by current flow.

(Note 2) The term "storage" refers to products stored for long period of time prior to mounting and use.

Operating temperature and humidity range covers connectors after installation, storage, shipment or during transportation.

Materials

| Items | Parts | Materials | Treatment | UL Specification | |
|---------------|-----------|-----------------|-----------------|------------------|---------|
| Receptacle | DF59 | Insulator | LCP | Natural | UL94V-0 |
| | | Contact | Phosphor bronze | Gold plated | _____ |
| Floating plug | DF59 | Contact | Phosphor bronze | Tin plated | _____ |
| | | Insulator | PBT | White | UL94V-0 |
| | DF59S | Contact | Brass | Gold plated | _____ |
| | | Insulator | LCP | Natural | UL94V-0 |
| | DF59SN | Contact | Brass | Tin plated | _____ |
| | | Insulator | LCP | Natural | UL94V-0 |
| Short pin | Contact | Brass | Tin plated | _____ | |
| | Insulator | PBT | White | UL94V-0 | |
| Crimp case | Insulator | PBT | White | UL94V-0 | |
| Crimp contact | Contact | Phosphor bronze | Gold plated | _____ | |

Ordering Information

Please refer to the ordering information below for each connector type

● Receptacle

DF **59** **#** - ***** **S** - **2** **V**

① ② ③ ④ ⑤ ⑥ ⑦

| | |
|---|---|
| ① Series Name: DF | ⑤ Type of connector S: Receptacle |
| ② Series No.: 59 | |
| ③ None: Standard S: Single contact type (Applied connector DF59S/SN-1P-FC) | ⑥ Pitch: Standard 2mm (4mm: Without the central contact) Single contact type Blank |
| ④ Number of contacts: 2, 3, 4 (Standard) 1 (Single contact type) | ⑦ Termination form V: SMT straight type |

● Floating plug

DF **59** **#** - ***** **P** - **2** **FC**

① ② ③ ④ ⑤ ⑥ ⑦

| | |
|---|---|
| ① Series Name: DF | ⑤ Type of connector P: Plug |
| ② Series No.: 59 | |
| ③ None: Standard S: Single contact type SN: Single contact slim type | ⑥ Pitch: Standard 2mm (4mm: Without the central contact) Single contact type Blank Single contact slim type Blank |
| ④ Number of contacts: 2, 3, 4 (Standard) 1 (Single contact type, Single contact slim type) | ⑦ Termination form FC: Floating |

● Short pin

DF **59** - ***** **P** - **2** **SP**

① ② ③ ④ ⑤ ⑥

| | |
|--------------------------------|---|
| ① Series Name: DF | ⑤ Pitch: 2mm |
| ② Series No.: 59 | ⑥ Termination form SP: Short Circuit pin |
| ③ Number of contacts: 2, 3 | |
| ④ Type of connector P: Plug | |

● Crimp Socket

DF **59** - ***** **P** - **2** **C**

① ② ③ ④ ⑤ ⑥

| | |
|--------------------------------|--|
| ① Series Name: DF | ⑤ Pitch: 2mm |
| ② Series No.: 59 | ⑥ Termination form C: Crimp Housing |
| ③ Number of contacts: 2, 3, 4 | |
| ④ Type of connector P: Plug | |

● Crimp contact

DF **59** - **22** **PCFA**

① ②

| | |
|--------------------------------------|--|
| ① Applicable Wire Size 22: AWG#22 | ② Form Type/Package Type PCFA: Crimp plug contact = Reel PCA: Crimp plug contact = Bulk Crimp contacts are required on the DF59-*P-2C part. |
|--------------------------------------|--|

■ Straight Receptacle (SMT)

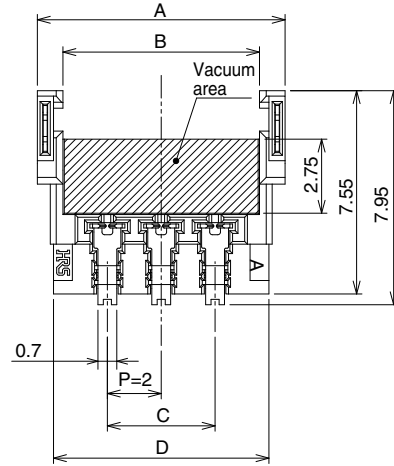

◆ Recommended PCB Dimensions (t=1.6mm)

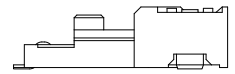
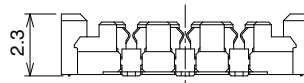
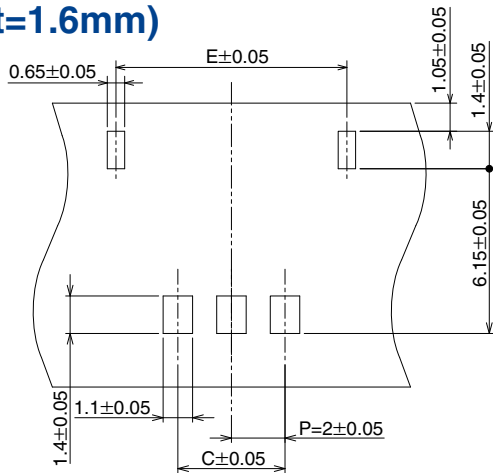

[Specification No.]

(51): Gold plating, emboss packaging

Unit : mm

| Part No. | HRS No. | No. of contacts | A | B | C | D | E |
|----------------|---------------|-----------------|------|-----|-----|------|-------|
| DF59-2S-2V(51) | 667-0001-0 51 | 2 | 7.2 | 5.3 | 2.0 | 6.0 | 6.62 |
| DF59-3S-2V(51) | 667-0002-3 51 | 3 | 9.2 | 7.3 | 4.0 | 8.0 | 8.62 |
| DF59-4S-2V(51) | 667-0003-6 51 | 4 | 11.2 | 9.3 | 6.0 | 10.0 | 10.62 |
| DF59-2S-4V(51) | 667-0021-8 51 | 2* | 9.2 | 7.3 | 4.0 | 8.0 | 8.62 |

* DF59-2S-4V(51) is made by removing the middle pin of DF59-3S-2V(51) at the factory.

(Note) Please order in full reel quantities. (2,000 pcs/reel)

● Carrier Tape Dimensions

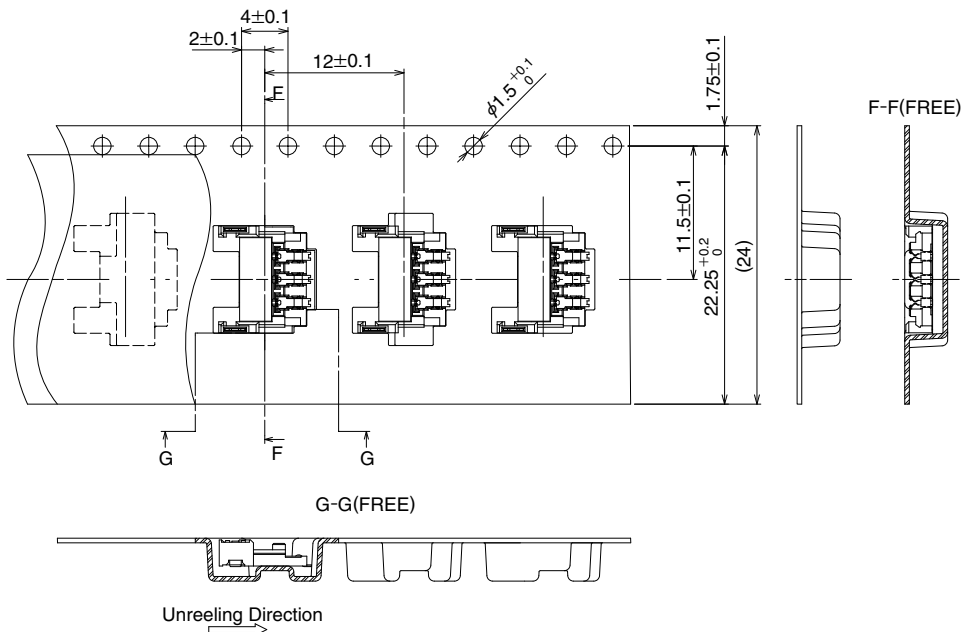

Single Contact Type Straight Receptacle (SMT)

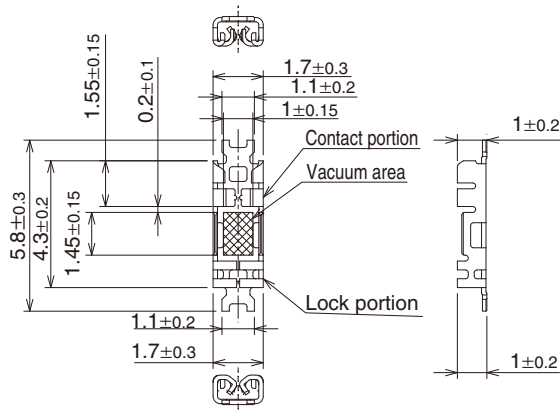

Recommended PCB Dimensions (t=1.6mm)

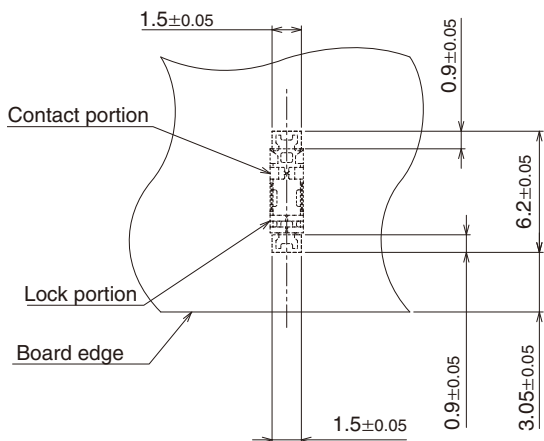

Recommended PCB Layout for parallel positioning

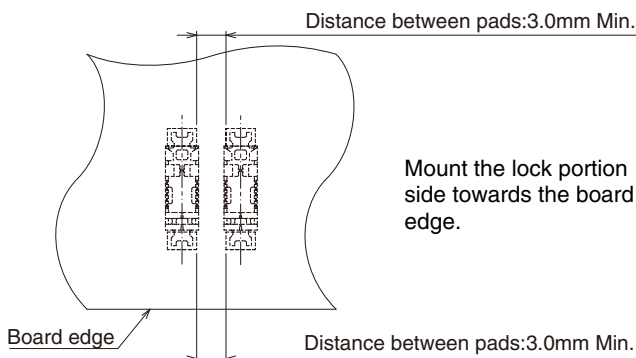

| Part No. | HRS No. | [Specification No.] |
|----------------|---------------|-------------------------------------|
| DF59S-1S-V(21) | 667-0024-6 21 | (21): Tin plating, emboss packaging |

(Note) Please order in full reel quantities. (10,000 pcs/reel)

Carrier Tape Dimensions

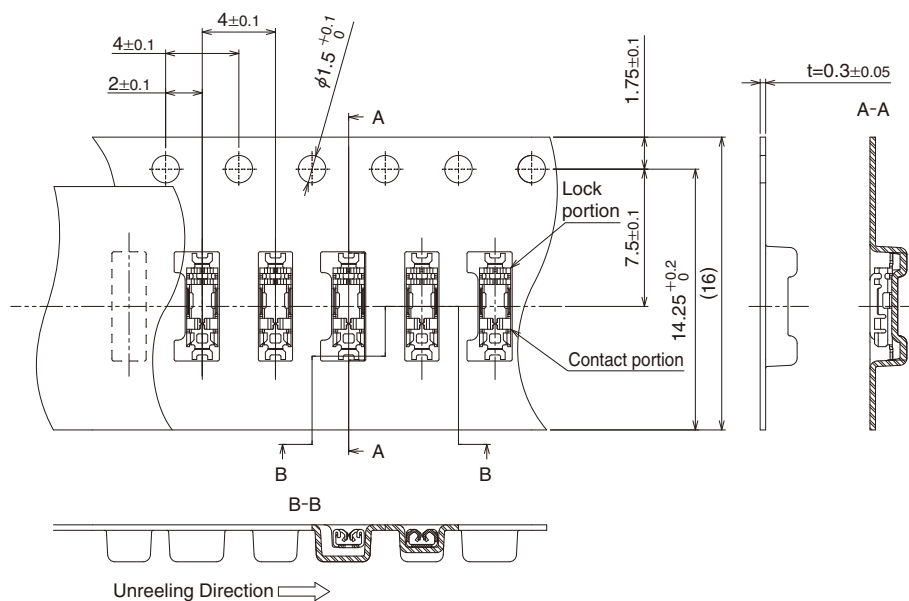

■ Floating plug

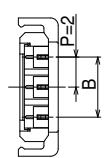
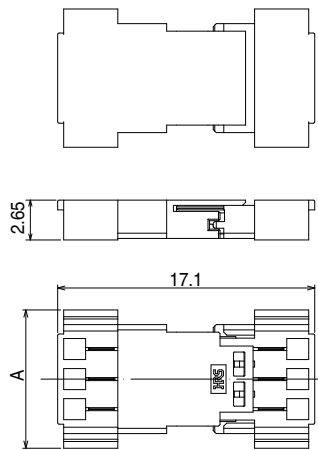
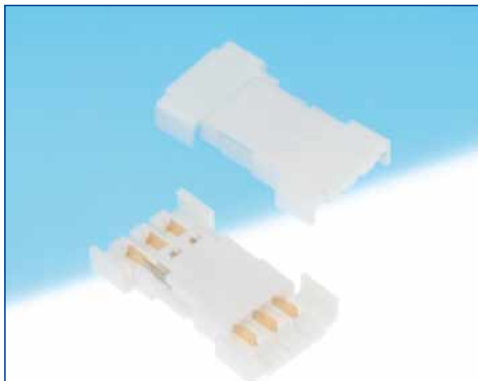

[Specification No.]
(50): Gold plating, tray packaging
Unit : mm

| Part No. | HRS No. | No. of contacts | A | B | Packaged Quantity/Tray |
|-----------------|---------------|-----------------|------|-----|------------------------|
| DF59-2P-2FC(50) | 667-0006-4 50 | 2 | 7.2 | 2.0 | 50 |
| DF59-3P-2FC(50) | 667-0007-7 50 | 3 | 9.2 | 4.0 | |
| DF59-4P-2FC(50) | 667-0008-0 50 | 4 | 11.2 | 6.0 | |
| DF59-2P-4FC(50) | 667-0020-5 50 | 2* | 9.2 | 4.0 | |

*DF59-2P-4FC(50) is made by removing the middle pin of DF59-3P-2FC(50) at the factory.
(Note) Please order in full tray quantities. (50 pcs/tray)

■ Single contact type floating plug

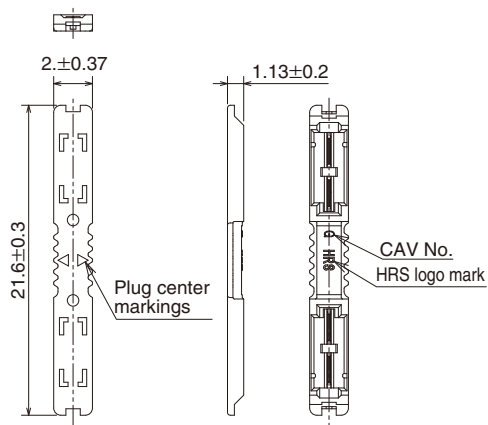

| Part No. | HRS No. |
|-----------------|---------------|
| DF59S-1P-FC(21) | 667-0023-3 21 |

[Specification No.]
(21): Tin plating, emboss packaging

(Note) Please order in full reel quantities. (10,000 pcs/reel)

■ Single contact slim type floating plug

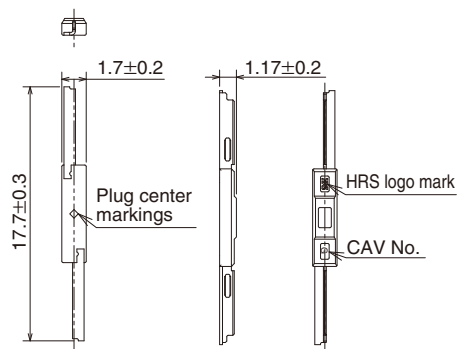

| Part No. | HRS No. |
|------------------|---------------|
| DF59SN-1P-FC(21) | 667-0028-7 21 |

[Specification No.]
(21): Tin plating, emboss packaging

(Note) Please order in full reel quantities. (10,000 pcs/reel)

(Note) Use the special (DF59SN-1P-FC/IN-TOOL) tool for connector insertion.

◆ Insertion Tool

| Part No. | HRS No. |
|----------------------|---------------|
| DF59SN-1P-FC/IN-TOOL | 667-0040-2 00 |

Short pin

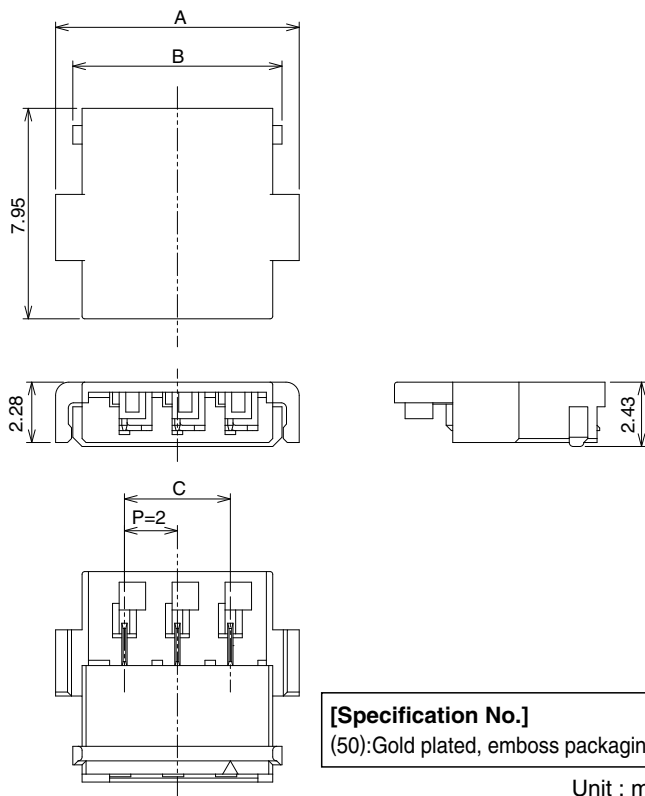

[Specification No.]
(50):Gold plated, emboss packaging

Unit : mm

| Part No. | HRS No. | No. of contacts | A | B | C | Packaged Quantity/Tray |
|-----------------|---------------|-----------------|-----|-----|-----|------------------------|
| DF59-2P-2SP(50) | 667-0017-0 50 | 2 | 7.2 | 5.9 | 2.0 | 100 |
| DF59-3P-2SP(50) | 667-0018-3 50 | 3 | 9.2 | 7.9 | 4.0 | |

(Note) Please order in full tray quantities. (100 pcs/tray)

Crimp Socket

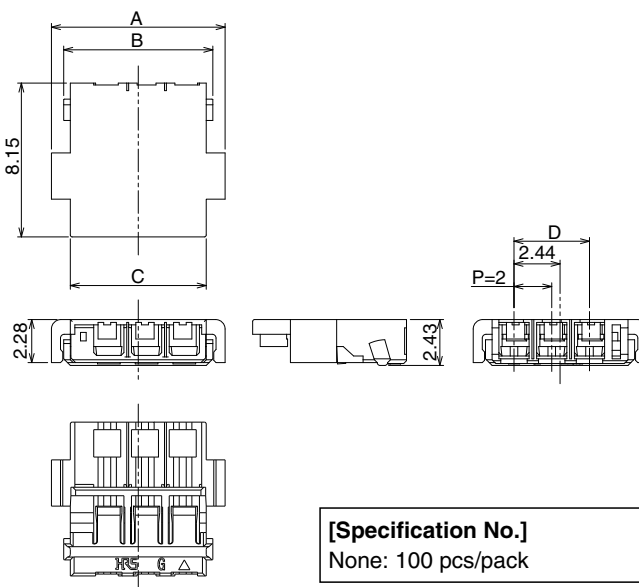

[Specification No.]
None: 100 pcs/pack

Unit : mm

| Part No. | HRS No. | No. of contacts | A | B | C | D |
|------------|---------------|-----------------|------|-----|-----|-----|
| DF59-2P-2C | 667-0011-4 00 | 2 | 7.2 | 5.9 | 5.2 | 2.0 |
| DF59-3P-2C | 667-0012-7 00 | 3 | 9.2 | 7.9 | 7.2 | 4.0 |
| DF59-4P-2C | 667-0013-0 00 | 4 | 11.2 | 9.9 | 9.2 | 6.0 |

(Note) Please order in full pack quantities. (100 pcs/pack)

■Crimp contact

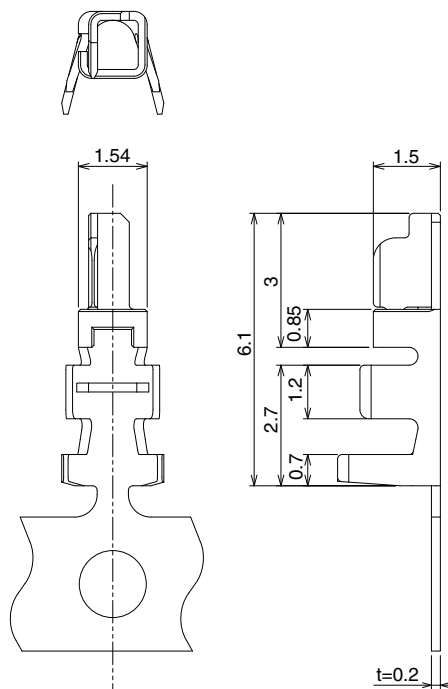

| Part No. | HRS No. | By Type | Quantity | Treatment |
|-------------|---------------|-----------------------|------------------------|-------------|
| DF59-22PCFA | 667-0016-8 00 | Reel contact (Note 1) | 10,000 contacts / reel | Gold plated |
| DF59-22PCA | 667-0022-0 00 | Bulk contact (Note 2) | 100 contacts / pack | |

(Note1) Please order reel contacts by full reel quantities. (10,000 pcs/reel)

(Note2) Please order loose piece contacts in full pack. (100 pcs/pack)

●Applicable Wire (Tin plated soft copper wire)

| Conductor Size (Wire Constitution) | Jacket Diameter |
|------------------------------------|------------------|
| AWG#22 (17 /φ0.16mm) | UL1061 (φ1.26mm) |
| | UL3265(φ1.38mm) |

(Note) Please contact your nearest Hirose Sales Representative for information regarding compatible wire Remarks: Please consult with our sales representative when using wires other than applicable wire.

●Recommended Wire

UL1061, UL3265

●Strip Length

1.7-2.3mm

◆Applicable Crimping Tool

| Types | Part No. | HRS No. | Applicable Contact |
|-----------------|----------------|---------------|---------------------------|
| Applicator | AP105-DF59-22P | 901-4619-8 00 | DF59-22PCFA |
| Press Unit | CM-105 | 901-0005-4 00 | - |
| Hand Tool | HT801/DF59-22P | 902-4638-9 00 | DF59-22PCA |
| Extraction Tool | DF-C-PO(B) | 550-0179-2 00 | DF59-22PCFA DF59-22PCA |

It is possible to use tooling from the AP105-DF11-22S applicator. Certain parts will need the be changed out. Please contact Hirose for details.

Note: Customers are strongly encouraged to utilize HRS application tooling or tooling created by a Hirose tooling partner. Hirose assumes no liability for customers using tooling from non-recognized sources.

◆ Mating Dimensions

● Board-to-board connection (floating plug)

[Standard]

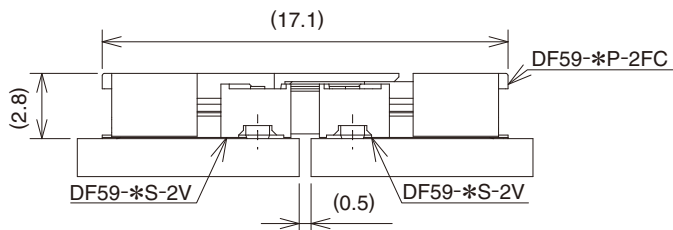

[Single contact type]

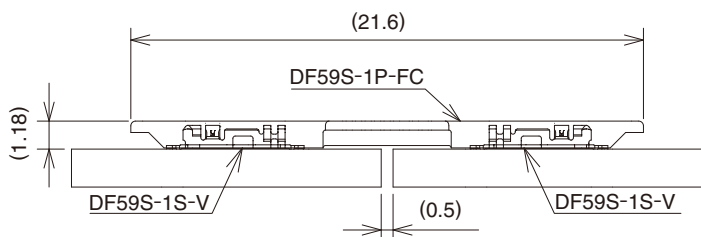
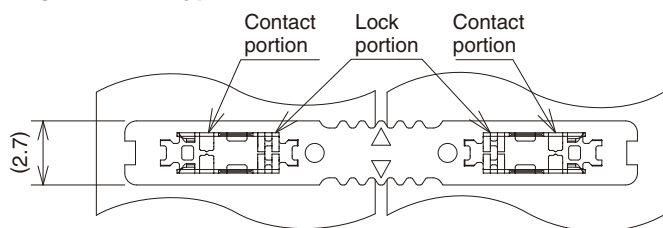

[Single contact slim type]

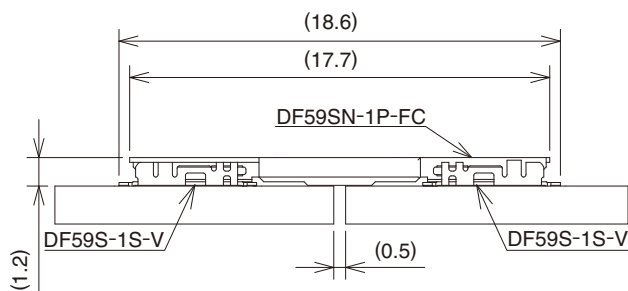
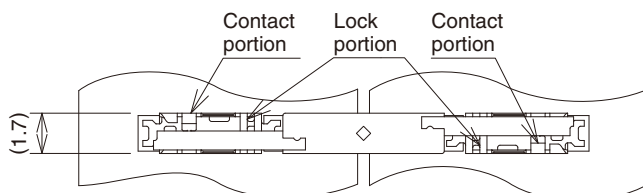

● Wire-to-board connection

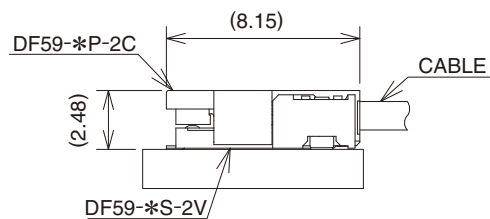

● Short-circuit pin connection

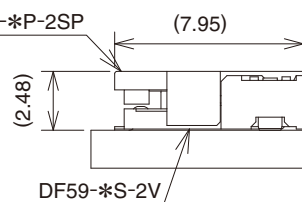

◆ Operating Precautions

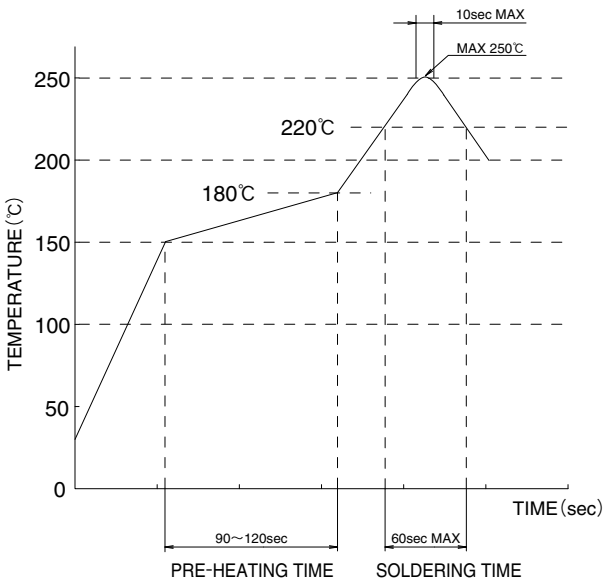
| | |
|--|--|
| <p>1. Recommended Temperature Profile (Lead-free soldering possible)</p> |  <p>[Applicable Conditions]</p> <ol style="list-style-type: none"> 1. Peak Temperature: MAX 250°C 2. Heated Area: 220°C or above, within 60 sec. 3. Pre-heating Area: 150-180°C, 90-120 sec. 4. Number of Times: within 2 times <p>*Measured at contact lead area Please be noted that the reflow condition may vary depending on soldering paste type, manufacturer of soldering material, board size, as well as conditions of other mounting materials. (*1) Above temperature profile is our recommended value.</p> |
| <p>2. Recommended Hand Solder Conditions</p> | <p>Soldering iron temperature: 350 ± 10°C, soldering time: within 3 seconds</p> |
| <p>3. Recommended Screen Thickness, Open Ratio (Pattern Area Ratio)</p> | <p>Thickness 0.1 mm, Open ratio: 100%</p> |
| <p>4. Warpage of PC board</p> | <p>Maximum of 0.02mm at the connector center, with both ends of the connector as reference points.</p> |
| <p>5. Cleaning Condition</p> | <p>Cleaning with IPA is possible. (Cleaning is not recommended. In case of cleaning, please evaluate if it causes a decrease in the performance which includes mechanical operation and environmental resistance.)</p> |
| <p>6. Precautions</p> | <ul style="list-style-type: none"> ■ When inserting crimp-type (solderless) terminals to crimping (solderless) sockets, to maintain reliable performance, please do not insert obliquely. ■ DO NOT mate/un-mate a non-terminated plug with a non-mounted receptacles. This may lead to damage or deformation of the contacts. ■ Please note that pulling on the wires or cable during un-mating may cause damage. ■ DO NOT apply flux to the contact terminals when hand soldering the receptacle to the board. Flux can wick into the electrical contact areas and may lead to connection failures. ■ Slight discoloration on the insulating materials will not affect form, fit or function of the connectors. ■ For operating suggestions on insertion and removal, please refer to the "DF59 Insertion and Removal Manual", "DF59S Insertion and Removal Manual", "DF59SN Insertion and Removal Manual" ■ Please refer to the documents "Cable assembly procedure", "Crimp condition" and "Crimp quality standard" for the cable assembly procedures. |

MEMO :

A series of horizontal dashed lines for taking notes.

USA:

HIROSE ELECTRIC (U.S.A.), INC. Headquarters
 2688 Westhills Court, Simi Valley, CA 93065-6235
 Phone : +1-805-522-7958
 Fax : +1-805-522-3217
<http://www.hiroseusa.com>

USA:

HIROSE ELECTRIC (U.S.A.), INC. San Jose Office
 3255 Scott Boulevard, Building 7, Suite 101
 Santa Clara, CA 95054
 Phone : +1-408-253-9640
 Fax : +1-408-253-9641
<http://www.hiroseusa.com>

USA:

HIROSE ELECTRIC (U.S.A.), INC. Detroit Office (Automotive)
 37677 Professional Center Drive, Suite #100C
 Livonia, MI 48154
 Phone : +1-734-542-9963
 Fax : +1-734-542-9964
<http://www.hiroseusa.com>

THE NETHERLANDS:

HIROSE ELECTRIC EUROPE B.V.
 Hogehillweg #8 1101 CC Amsterdam Z-O
 Phone : +31-20-6557460
 Fax : +31-20-6557469
<http://www.hiroseeurope.com>

GERMANY:

HIROSE ELECTRIC EUROPE B.V. German Branch
 Herzog-Carl-Strasse 4 D-73760 Ostfildern
 (Scharnhauser Park)
 Phone : +49-711-4560-02-1
 Fax : +49-711-4560-02-299
<http://www.hirose.de>

GERMANY:

HIROSE ELECTRIC EUROPE B.V. Nuernberg Office
 Muggenhofer Str. 136 90429 Nuernberg
 Phone : +49-911 32 68 89 63
 Fax : +49-911 32 68 89 69
<http://www.hirose.de>

UNITED KINGDOM:

Hirose Electric Europe BV (UK Branch)
 4 Newton Court, Kelvin Drive, Knowlhill,
 Milton Keynes, MK5 8NH
 Phone : +44-1908 202050
 Fax : +44-1908 202058

CHINA:

HIROSE ELECTRIC (SHANGHAI) CO., LTD.
 1601, Henderson Metropolitan, NO.300, East Nanjing
 Road, Huangpu District, Shanghai, China 200001
 Phone : +86-21-6391-3355
 Fax : +86-21-6391-3335
<http://www.hirose-china.com.cn>

CHINA:

HIROSE ELECTRIC (SHANGHAI) CO.,LTD. BEIJING BRANCH
 A1001, Ocean International Center, Building 56# East 4th
 Ring Middle Road, ChaoYang District, Beijing, 100025
 Phone : +86-10-5165-9332
 Fax : +86-10-5908-1381
<http://www.hirose-china.com.cn>

CHINA:

HIROSE ELECTRIC TECHNOLOGIES (SHENZHEN) CO., LTD.
 Room 09-13, 19/F, Office Tower Shun Hing Square, Di Wang Commercial Centre,
 5002 Shen Nan Dong Road, Shenzhen City, Guangdong Province, 518008
 Phone : +86-755-8207-0851
 Fax : +86-755-8207-0873
<http://www.hirose-china.com.cn>

HONG KONG:

HIROSE ELECTRIC HONGKONG TRADING CO., LTD.
 Room 1001, West Wing, Tsim Sha Tsui Centre, 66
 Mody Road, Tsim Sha Tsui East, Kowloon, Hong Kong
 Phone : +852-2803-5338
 Fax : +852-2591-6560
<http://www.hirose-hongkong.com.hk>

TAIWAN:

HIROSE ELECTRIC TAIWAN CO., LTD.
 103 8F, No.87, Zhengzhou Rd., Taipei
 Phone : +886-2-2555-7377
 Fax : +886-2-2555-7350
<http://www.hirose-taiwan.com.tw>

KOREA:

HIROSE KOREA CO., LTD.
 1261-10, Jeoungwhang-Dong, Shihung-City,
 Kyunggi-Do 429-450
 Phone : +82-31-496-7000,7124
 Fax : +82-31-496-7100
<http://www.hirose.co.kr>

SINGAPORE:

HIROSE ELECTRIC SINGAPORE PTE. LTD.
 10 Anson Road #26-1, International Plaza
 079903, Singapore
 Phone : +65-6324-6113
 Fax : +65-6324-6123
<http://www.hirose-singapore.com.sg>

INDIA:

HIROSE ELECTRIC SINGAPORE PTE. LTD Delhi Liaison Office
 Suite No. 606 5th Floor SB Tower 1A/1 Sector
 16 A Filmcity Noida 201301 Uttar Pradesh-India
 Phone : +91-120-4804917
 Fax : +91-120-4804949
<http://www.hirose.com/sg/>

INDIA:

HIROSE ELECTRIC SINGAPORE PTE. LTD. Bangalore Liaison office
 Unit No.03, Ground Floor, Explorer Building International Tech
 Park Whitefield Road, Bangalore 560066 Karnataka, India
 Phone : +91-80-4120 1907
 Fax : +91-80-4120 9908
<http://www.hirose-singapore.com.sg>

MALAYSIA:

HIROSE ELECTRIC SINGAPORE PTE. LTD (Representative office)
 1-10-07, Suntech @ Penang Cybercity (1164),Lintang
 Mayang Pasir 3,11950, Bayan Baru, Penang, Malaysia.
 Phone : +604-619-2564
 Fax : +604-619-2574
<http://www.hirose.com/sg/>



HIROSE ELECTRIC CO.,LTD.

2-6-3,Nakagawa Chuoh,Tsuzuki-Ku,Yokohama-Shi 224-8540,JAPAN
 TEL: +81-45-620-3526 Fax: +81-45-591-3726
<http://www.hirose.com>
<http://www.hirose-connectors.com>

AMEYA360

Components Supply Platform

Authorized Distribution Brand :



Website :

Welcome to visit www.ameya360.com

Contact Us :

➤ Address :

401 Building No.5, JiuGe Business Center, Lane 2301, Yishan Rd
Minhang District, Shanghai , China

➤ Sales :

Direct +86 (21) 6401-6692

Email amall@ameya360.com

QQ 800077892

Skype [ameyasales1](#) [ameyasales2](#)

➤ Customer Service :

Email service@ameya360.com

➤ Partnership :

Tel +86 (21) 64016692-8333

Email mkt@ameya360.com