

Power Tap Switches

High-current, Non-shorting Type

Model 711

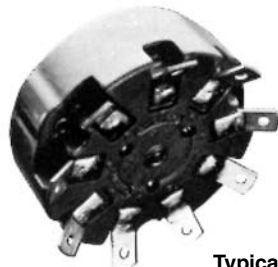

Typical ceramic style

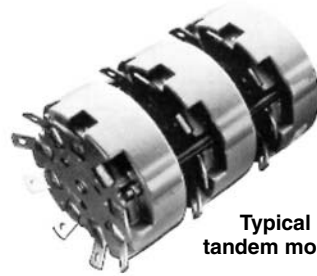

Typical tandem model

SPECIFICATIONS

Material

Body: Ceramic, arc-proof (models 212, 312, 412, 608). Compression Molded Polyester (model 111). Melamine Phenolic (model 711)

Contacts: Silver alloy. Common contact is rounded for assured seating. Self-cleaning with built in wiping action.

Terminals: Soldering. 711 also accepts quick connectors; 412, #10 screws; 608, 0.25" bolts.

Mounting

Model 711: Using 3/8-32 bushing for 1/8" thick maximum panel. Four non-turn lug positions are possible on the single, unenclosed switch. Recesses in body of switch permit positioning of non-turn washer at "12, 3, 6 and 9 o'clock." 3/16" hole for non-turn washer. Shaft 1/4"

Model 111: For 1/4" panel, maximum, using 3/8-32 bushing and hex nut. A 3/16" hole is required for the non-turn washer. Shaft 1/4"

Model 212: Using 3/8-32 threaded bushing and hex nut. A 5/32" hole is required for the non-turn pin. Shaft 1/4"

Model 312: For 1/4" panel, maximum, use three 10-32 flat-head machine screws 3/8" long. Shaft 1/4"

Model 412: For 1/4" panel, maximum, use three 10-32 flat-head machine screws 3/8" long. A 5/16" hole in panel is required for shaft.

Model 608: For 1" panel, maximum, three flat-head machining screws 1/4-20, 1 1/4" long. Drill a 7/16" hole in panel for shaft. Shaft 3/8"

NOTE: Since all tap switches are electro-mechanical devices, they are subject to wear and, therefore, have a finite life.

Model	Rating (AC)	Rating (DC)*	Max. no. of taps	Overall Diameter (max., in./mm)	Depth behind panel (in./mm)			Shaft Torque
					single	2 in tandem	3 in tandem	
711	7A 125V	7A 20V	11	1.56 / 39.6	13/16 / 20.6	125/32 / 45.2	215/32 / 62.7	7-12 oz.-in.
111	15A 125V	15A 20V	11	2.19 / 56	1 1/8 / 28.7	2 3/4 / 69.9	—	1.5-3.8 in.-lbs.
212	20A 150V	20A 20V	12	2.25 / 57	1 3/4 / 44.5	4 3/16 / 106.4	6 3/16 / 157.2	3-7 in.-lbs.
312	30A 300V	30A 20V	12	3.31 / 84	2 1/4 / 57.2	4 5/8 / 117.5	7 / 177.8	3-7 in.-lbs.
412	50A 300V	50A 20V	12	4.25 / 108	2 7/16 / 61.9	5 1/32 / 127.8	7 5/8 / 193.7	3-8 in.-lbs.
608	100A 300V	100A 20V	8	6.25 / 159	3 5/16 / 84.1	6 13/16 / 173.0	10 5/16 / 261.9	25-35 in.-lbs.

*non-inductive load

All dimensions for reference only; consult factory for details.

Ohmite power Tap Switches (high power rotary switches) are constructed to provide dependable, convenient operation.

All Ohmite tap switches, from 15 to 100 amps, have ceramic arc-proof bodies and metal alloy contacts. Their all-soldered and all-riveted construction assures mechanical and operational integrity. Even the smallest Ohmite Tap

Switch, rated at 7 amps, has a reinforced non-metal body and solid metal alloy contacts. These units feature high current handling capability in a small package.

FEATURES

- "Slow-breaking, Quick-make" action proved best for switching AC current.
- Non-shorting type disconnects previous circuit before establishing contact for succeeding tap.

- Ceramic and metal construction provides resistance to arcing, burning and charring.
- Tandem assemblies available as standard models.
- UL listed for models 111, 212, 312 and 412
- RoHS compliant product available Jan. 2006 Add "E" suffix to part number to specify.

STANDARD PART NUMBERS FOR POWER TAP SWITCHES

Number of taps*	Total rotation	Model 711 7A - 125V			Model 111 15A - 125V			Model 212 20A - 150V			Model 312 30A - 300V			Model 412 50A - 300V			Model 608 100A - 300V		
		711-*	711--T2	711--T3	111-*	111--T2	111--T3	212-*	212--T2	212--T3	312-*	312--T2	312--T3	412-*	412--T2	412--T3	608-*	608--T2	608--T3
3	60°	❖	❖	❖	❖	❖	❖	❖	❖	❖	❖	❖	❖	❖	❖	❖	❖	❖	❖
4	90°	❖	❖	❖	❖	❖	❖	❖	❖	❖	❖	❖	❖	❖	❖	❖	❖	❖	❖
5	120°	❖	❖	❖	❖	❖	❖	❖	❖	❖	❖	❖	❖	❖	❖	❖	❖	❖	❖
6	150°	❖	❖	❖	❖	❖	❖	❖	❖	❖	❖	❖	❖	❖	❖	❖	❖	❖	❖
7	180°	❖	❖	❖	❖	❖	❖	❖	❖	❖	❖	❖	❖	❖	❖	❖	❖	❖	❖
8	210°	❖	❖	❖	❖	❖	❖	❖	❖	❖	❖	❖	❖	❖	❖	❖	❖	❖	❖
9	240°	❖	❖	❖	❖	❖	❖	❖	❖	❖	❖	❖	❖	❖	❖	❖	❖	❖	❖
10	270°	❖	❖	❖	❖	❖	❖	❖	❖	❖	❖	❖	❖	❖	❖	❖	❖	❖	❖
11	300°	❖	❖	❖	❖	❖	❖	❖	❖	❖	❖	❖	❖	❖	❖	❖	❖	❖	❖
12	330°	❖	❖	❖	❖	❖	❖	❖	❖	❖	❖	❖	❖	❖	❖	❖	❖	❖	❖

Check product availability at www.ohmite.com

See page 82 for knobs, dials, and other hardware

❖ = Non-standard values subject to minimum handling charge per item
* Insert number of taps at asterisk for complete part number (e.g. 111-3-T2)

Power Tap Switches

High-current, Non-shorting Type

Model 111

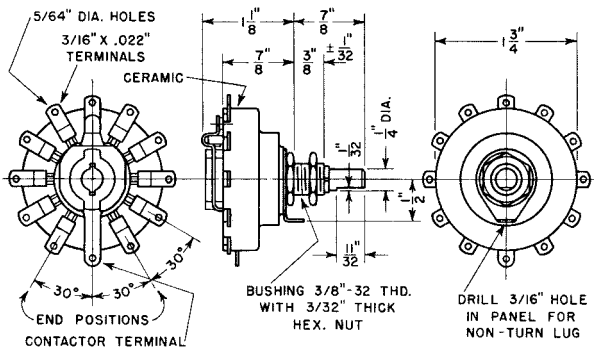

Model 212

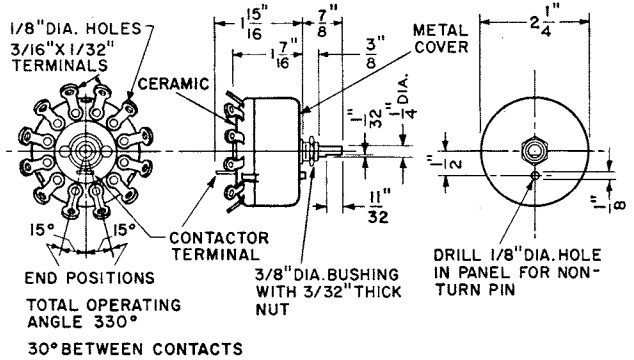

Model 312

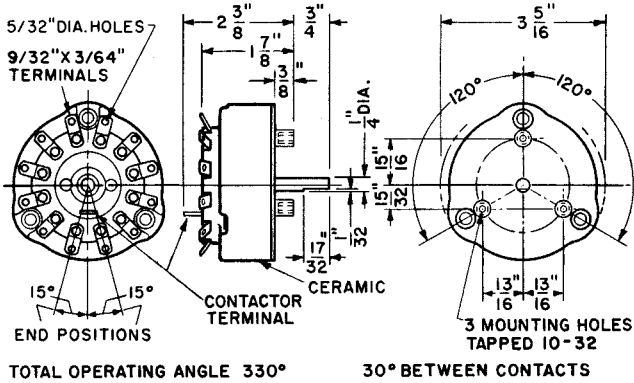

Model 412

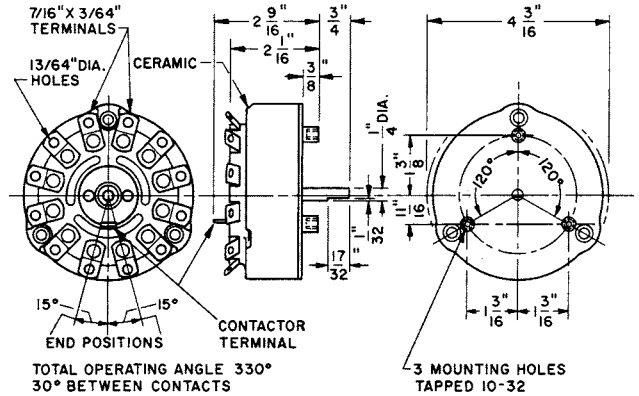

Model 608

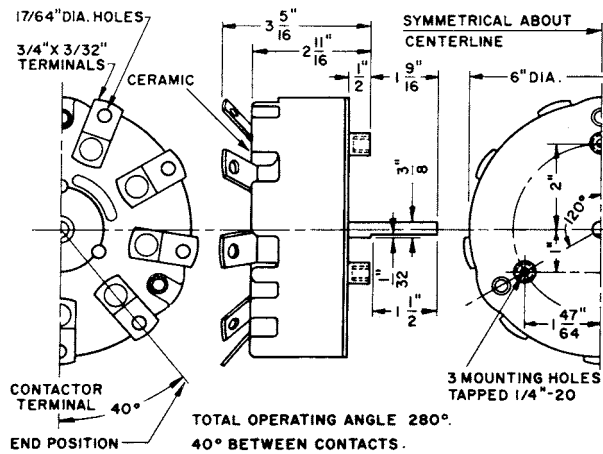

AMEYA360

Components Supply Platform

Authorized Distribution Brand :



Website :

Welcome to visit www.ameya360.com

Contact Us :

➤ Address :

401 Building No.5, JiuGe Business Center, Lane 2301, Yishan Rd
Minhang District, Shanghai , China

➤ Sales :

Direct +86 (21) 6401-6692

Email amall@ameya360.com

QQ 800077892

Skype [ameyasales1](#) [ameyasales2](#)

➤ Customer Service :

Email service@ameya360.com

➤ Partnership :

Tel +86 (21) 64016692-8333

Email mkt@ameya360.com