

FSB44104A

Motion SPM® 45 LV Series

Features

- UL Certified No.E209204 (UL1557)
- 40 V, $R_{DS(ON)} = 4.1 \text{ m}\Omega(\text{Max.})$ 3-Phase MOSFET Inverter Module with Gate Drivers and Protection
- Low Thermal Resistance Using Ceramic Substrate
- Three Separate Open-Emitter Pins from Low-Side MOSFETs for Three-Leg Current Sensing.
- Single-Grounded Power Supply for Built-in HVIC.
- Isolation Rating: $800 \text{ V}_{\text{rms}} / \text{min.}$

Applications

- Motion Control - Home Appliance / Industrial Motor.

General Description

FSB44104A is a Motion SPM® 45 LV module that Fairchild developed based on low-loss PowerTrench® MOSFET technology as a compact motor drive inverter solution for small power applications supplied by low voltage battery.



Figure 1. Packing Overview

Package Marking and Ordering Information

Device	Device Marking	Package	Packing Type	Quantity
FSB44104A	FSB44104A	SPMAA-A22	Rail	14

Integrated Power Functions

- 40 V $R_{DS(ON)} = 2.5 \text{ m}\Omega$ (typ.) inverter for three-phase DC / AC power conversion (please refer to Figure 3)

Integrated Drive, Protection, and System Control Functions

- For inverter high-side MOSFETs: gate drive circuit, high-voltage isolated high-speed level shifting, Under-Voltage Lock-Out (UVLO) Protection.
- For inverter low-side IGBTs: gate drive circuit, Under-Voltage Lock-Out (UVLO) Protection.
- Fault signaling: corresponding to UV (low-side supply).
- Input interface: active-HIGH interface, works with 3.3 / 5 V logic, Schmitt-trigger input

Pin Configuration

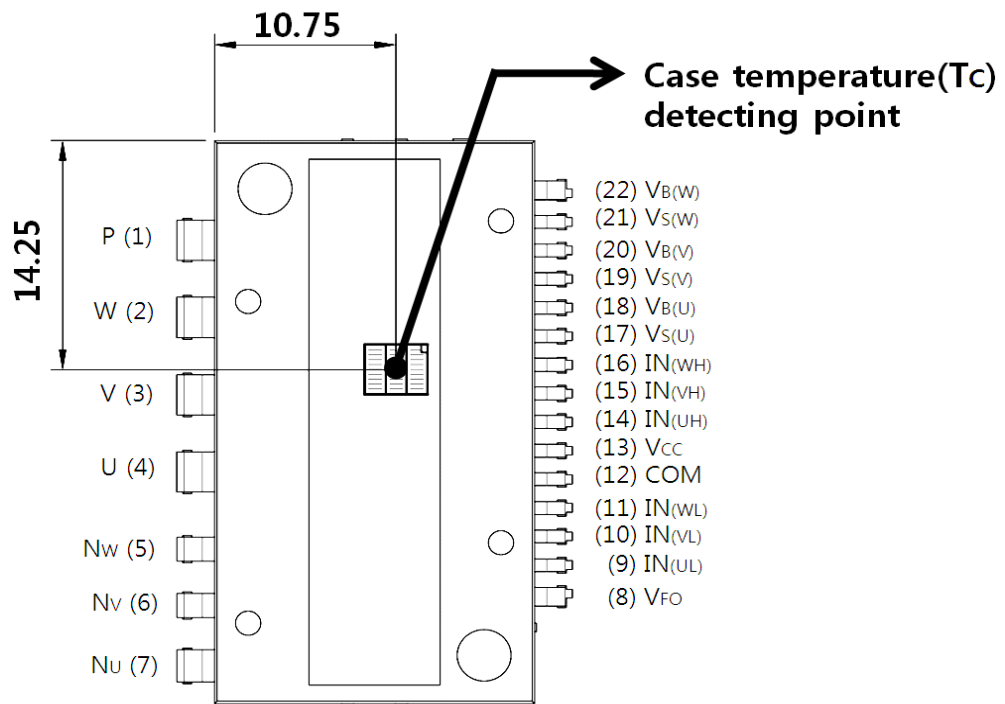

Figure 2. Top View

Pin Descriptions

Pin Number	Pin Name	Pin Description
1	P	Positive DC-Link Input
2	W	W Phase Output
3	V	V Phase Output
4	U	U Phase Output
5	N _W	Negative DC-Link Input
6	N _V	Negative DC-Link Input
7	N _U	Negative DC-Link Input
8	V _{FO}	Fault Output
9	IN _(UL)	PWM Input for Low-Side U-Phase MOSFET Drive
10	IN _(VL)	PWM Input for Low-Side V-Phase MOSFET Drive
11	IN _(WL)	PWM Input for Low-Side W-Phase MOSFET Drive
12	COM	Common Supply Ground
13	V _{CC}	Common Supply Voltage for IC and Low-side MOSFET Drive
14	IN _(UH)	PWM Input for High-Side U-Phase MOSFET Drive
15	IN _(VH)	PWM Input for High-Side V-Phase MOSFET Drive
16	IN _(WH)	PWM Input for High-Side W-Phase MOSFET Drive
17	V _{B(U)}	Supply Voltage for High-Side U-Phase MOSFET Drive
18	V _{S(U)}	Supply Ground for High-Side U-Phase MOSFET Drive
19	V _{B(V)}	Supply Voltage for High-Side V-Phase MOSFET Drive
20	V _{S(V)}	Supply Ground for High-Side V-Phase MOSFET Drive
21	V _{B(W)}	Supply Voltage for High-Side W-Phase MOSFET Drive
22	V _{S(W)}	Supply Ground for High-Side W-Phase MOSFET Drive

Internal Equivalent Circuit and Input/Output Pins

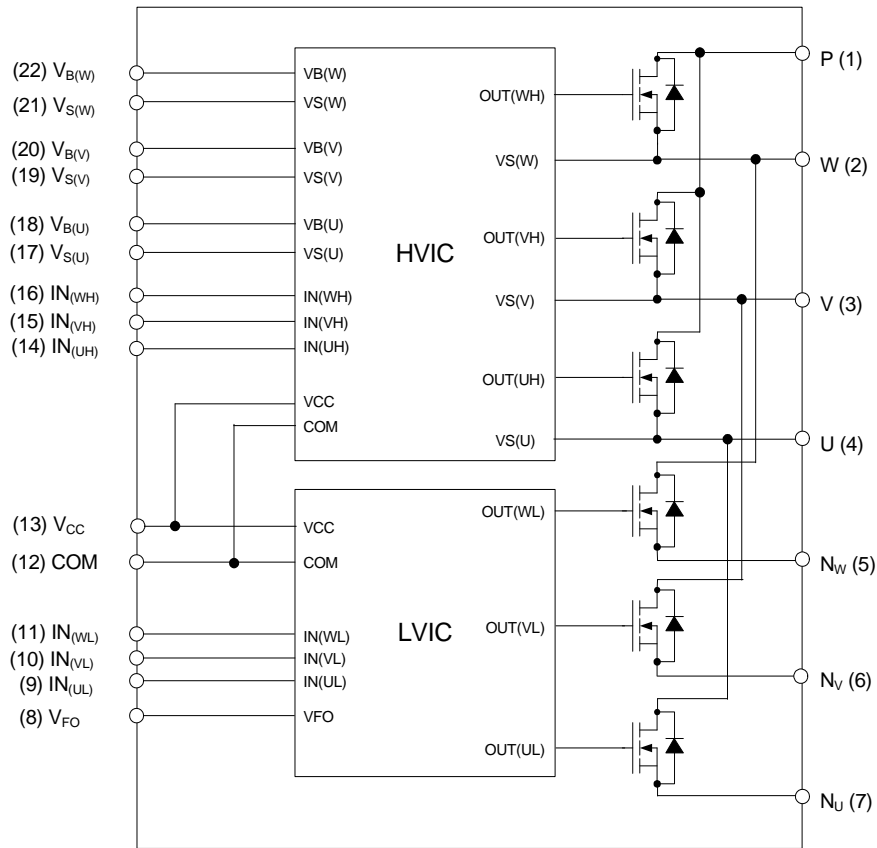

Figure 3. Internal Block Diagram

Absolute Maximum Ratings ($T_J = 25^\circ\text{C}$, unless otherwise specified.)**Inverter Part**

Symbol	Parameter	Conditions	Rating	unit
V_{PN}	DC-Link Input Voltage Drain - Source Voltage	Applied between P - $N_{(U)}$, $N_{(V)}$, $N_{(W)}$	40	V
$* \pm I_D$	Drain Current	$T_C = 25^\circ\text{C}$, $T_J \leq 150^\circ\text{C}$ $T_C = 100^\circ\text{C}$, $T_J \leq 150^\circ\text{C}$	57 36	A A
$* \pm I_{DP}$	Peak Drain Current	$T_C = 25^\circ\text{C}$, under 1ms Pulse Width, $T_J \leq 150^\circ\text{C}$	110	A
$* P_D$	Maximum Power Dissipation	$T_C = 25^\circ\text{C}$, per Chip, $T_J \leq 150^\circ\text{C}$	28	W
T_J	Operating Junction Temperature		-40 ~ 150	$^\circ\text{C}$

1st Notes:

1. Rating value of marking "*" is calculation value or design factor.

Control Part

Symbol	Parameter	Conditions	Rating	unit
V_{CC}	Supply Voltage	Applied between V_{CC} - COM	20	V
V_{BS}	Supply Voltage	Applied between $V_{B(U)}$ - $V_{S(U)}$, $V_{B(V)}$ - $V_{S(V)}$, $V_{B(W)}$ - $V_{S(W)}$	20	V
V_{IN}	PWM Signal Voltage	Applied between $IN_{(UH)}$, $IN_{(VH)}$, $IN_{(WH)}$, $IN_{(UL)}$, $IN_{(VL)}$, $IN_{(WL)}$ - COM	-0.3 ~ $V_{CC}+0.3$	V
V_{FO}	Fault Output Supply Voltage	Applied between V_{FO} - COM	-0.3 ~ $V_{CC}+0.3$	V
I_{FO}	Fault Output Current	Sink Current at V_{FO} Pin	1	mA

Total System

Symbol	Parameter	Conditions	Rating	unit
T_{STG}	Storage Temperature		-40 ~ 150	$^\circ\text{C}$
V_{ISO}	Isolation Voltage	60 Hz, Sinusoidal, AC 1 Minute, Connect Pins to Heat-Sink Plate	800	V_{rms}

Thermal Characteristics

Symbol	Parameter	Condition	Max.	unit
$R_{th(j-c)}$	Junction to Case Thermal Resistance	Package center (per MOSFET)	4.41	$^\circ\text{C/W}$

Electrical Characteristics ($T_J = 25^\circ\text{C}$, unless otherwise specified.)

Inverter Part

Symbol	Parameter	Conditions	Min.	Typ.	Max.	Unit		
BV_{DSS}	Drain - Source Breakdown Voltage	$V_{IN} = 0\text{ V}$, $I_D = 250\ \mu\text{A}$ (2nd Notes 1)	40	-	-	V		
$R_{DS(ON)}$	Drain - Source Turn-On Resistance	$V_{CC} = V_{BS} = 15\text{ V}$, $V_{IN} = 5\text{ V}$, $I_D = 40\text{ A}$	-	3.0	4.1	m Ω		
V_{SD}	Source - Drain Diode Forward Voltage	$V_{CC} = V_{BS} = 15\text{ V}$, $V_{IN} = 0\text{ V}$, $I_{SD} = 40\text{ A}$	-	0.8	1.1	V		
t_{ON}	Switching Characteristic	$V_{PN} = 20\text{ V}$, $V_{CC} = V_{BS} = 15\text{ V}$, $I_D = 40\text{ A}$, $V_{IN} = 0\text{ V} \leftrightarrow 5\text{ V}$, High-side, Inductive Load (1st Note 3)	-	1200	-	ns		
$t_{C(ON)}$			-	1140	-	ns		
t_{OFF}			-	1700	-	ns		
$t_{C(OFF)}$			-	500	-	ns		
t_{rr}			-	70	-	ns		
I_{rr}			-	5	-	A		
t_{ON}			$V_{PN} = 20\text{ V}$, $V_{CC} = V_{BS} = 15\text{ V}$, $I_D = 40\text{ A}$, $V_{IN} = 0\text{ V} \leftrightarrow 5\text{ V}$, Low side, Inductive Load (1st Note 3)	-	1370	-	ns	
$t_{C(ON)}$				-	1000	-	ns	
t_{OFF}				-	1850	-	ns	
$t_{C(OFF)}$				-	600	-	ns	
t_{rr}				-	75	-	ns	
I_{rr}				-	4	-	A	
I_{DSS}				Drain - Source Leakage Current	$V_{DS} = V_{DSS}$	-	-	250

1st Notes:

- BV_{DSS} is the absolute maximum voltage rating between drain and source terminal of each MOSFET. V_{PN} should be sufficiently less than this value considering the effect of the stray inductance so that V_{DS} should not exceed BV_{DSS} in any case.
- t_{ON} and t_{OFF} include the propagation delay of the internal drive IC. $t_{C(ON)}$ and $t_{C(OFF)}$ are the switching time of MOSFET itself under the given gate driving condition internally. For the detailed information, please see Figure 4.

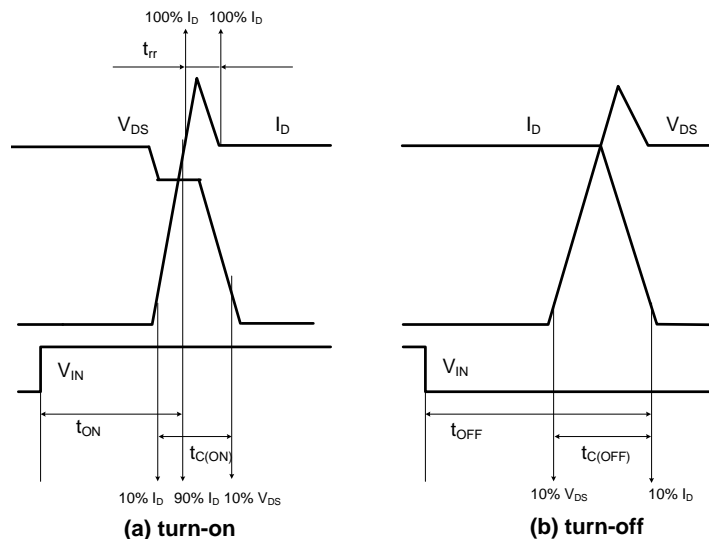

Figure 4. Switching Time Definition

Control Part

Symbol	Parameter	Conditions		Min.	Typ.	Max.	Unit
I_{OCC}	Quiescent V_{CC} Supply Current	$V_{CC} = 15\text{ V}$, $V_{IN} = 0\text{ V}$	$V_{CC} - \text{COM}$	-	-	2.75	mA
I_{OBS}	Quiescent V_{BS} Supply Current	$V_{BS} = 15\text{ V}$, $V_{IN} = 0\text{ V}$	$V_{B(U)} - V_{S(U)}$, $V_{B(V)} - V_{S(V)}$, $V_{B(W)} - V_{S(W)}$	-	-	0.3	mA
V_{FOH}	Fault Output Voltage	10 k Ω to 5 V Pull-up	Normal	4.5	-	-	V
V_{FOL}			Fault	-	-	0.5	V
UV_{CCD}	Supply Circuit Under-Voltage Protection	Detection Level		7.0	8.2	10.0	V
UV_{CCR}		Reset Level		8.0	9.4	11.0	V
UV_{BSD}		Detection Level		7.0	8.0	9.5	V
UV_{BSR}		Reset Level		8.0	9.0	10.5	V
t_{FOD}	Fault-Out Pulse Width			30	-	-	μs
$V_{IN(ON)}$	ON Threshold Voltage	Applied between $IN_{(UH)}$, $IN_{(VH)}$, $IN_{(WH)}$, $IN_{(UL)}$,		-	-	2.6	V
$V_{IN(OFF)}$	OFF Threshold Voltage	$IN_{(VL)}$, $IN_{(WL)} - \text{COM}$		0.8	-	-	V

Recommended Operating Conditions

Symbol	Parameter	Conditions	Min.	Typ.	Max.	Unit
V_{PN}	Supply Voltage	Applied between P - $N_{(U)}$, $N_{(V)}$, $N_{(W)}$	-	20	-	V
V_{CC}	Control Supply Voltage	Applied between $V_{CC} - \text{COM}$	13.5	15.0	16.5	V
V_{BS}	Control Supply Voltage	Applied between $V_{B(U)} - V_{S(U)}$, $V_{B(V)} - V_{S(V)}$, $V_{B(W)} - V_{S(W)}$	13.0	15.0	18.5	V
dV_{CC}/dt , dV_{BS}/dt	Control Supply Variation		-1	-	1	V / μs
V_{SEN}	Voltage for Current Sensing	Applied between N_U , N_V , $N_W - \text{COM}$ (Including Surge Voltage)	-4	-	4	V

Mechanical Characteristics and Ratings

Parameter	Conditions		Limits			Units
			Min.	Typ.	Max.	
Mounting Torque	Mounting Screw: M3		0.51	0.62	0.72	N•m
Device Flatness		See Figure 5	-	-	120	μm
Weight			-	8.4	-	g

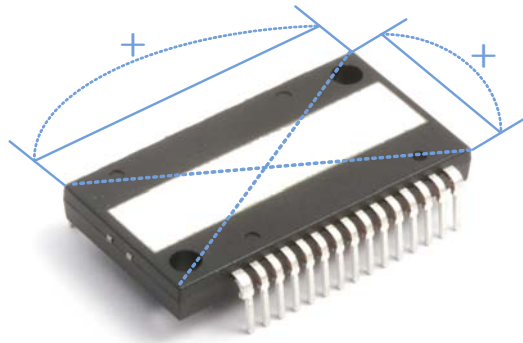
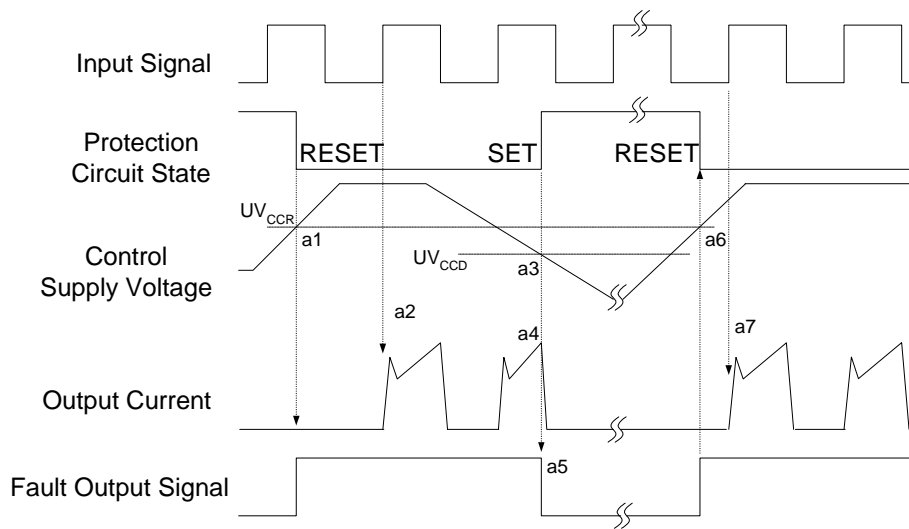

Figure 5. Flatness Measurement Position

Time Charts of Protective Function



- a1 : Control supply voltage rises: after the voltage rises UV_{CCR} , the circuits start to operate when the next input is applied.
- a2 : Normal operation: MOSFET ON and carrying current.
- a3 : Under-voltage detection (UV_{CCD}).
- a4 : MOSFET OFF in spite of control input condition.
- a5 : Fault output operation starts.
- a6 : Under-voltage reset (UV_{CCR}).
- a7 : Normal operation: MOSFET ON and carrying current.

Figure 6. Under-Voltage Protection (Low-Side)

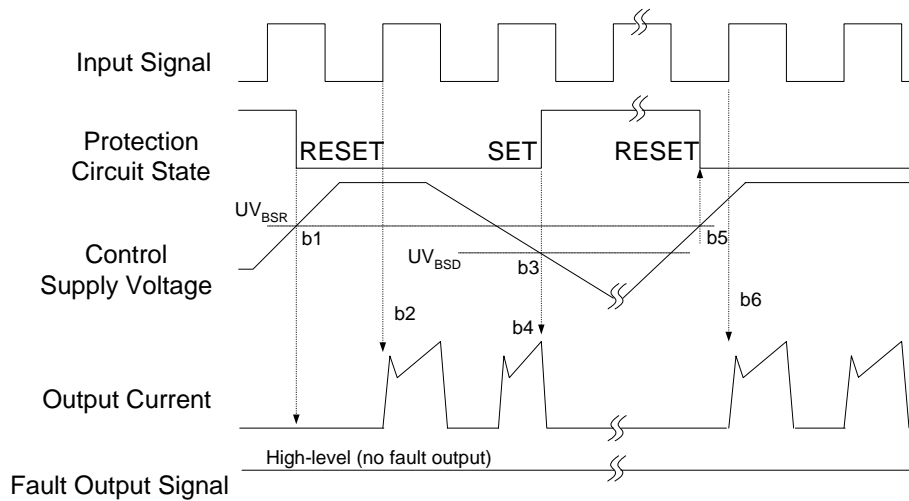

- b1 : Control supply voltage rises: after the voltage reaches UV_{BSR} , the circuits start to operate when the next input is applied.
- b2 : Normal operation: MOSFET ON and carrying current.
- b3 : Under-voltage detection (UV_{BSD}).
- b4 : MOSFET OFF in spite of control input condition, but there is no fault output signal.
- b5 : Under-voltage reset (UV_{BSR}).
- b6 : Normal operation: MOSFET ON and carrying current

Figure 7. Under-Voltage Protection (High-Side)

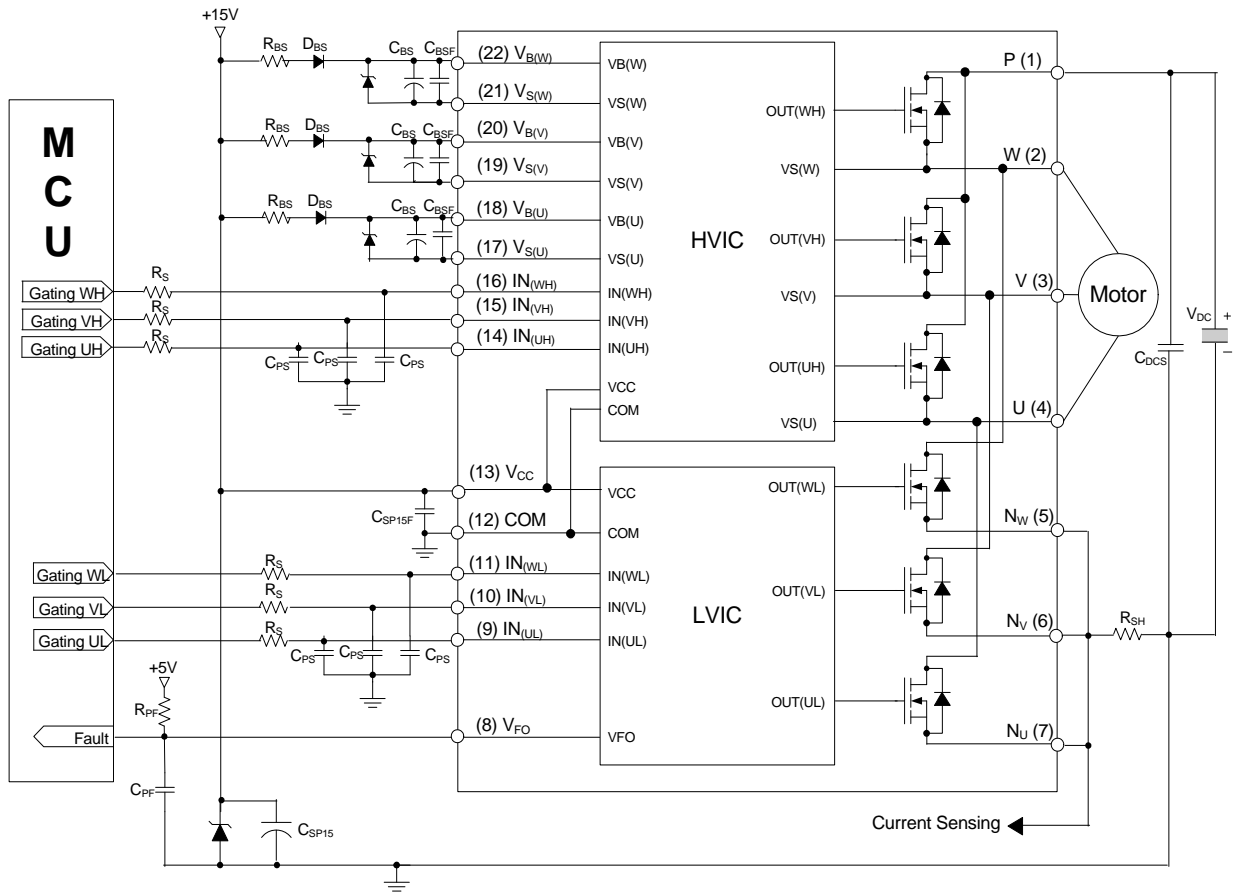
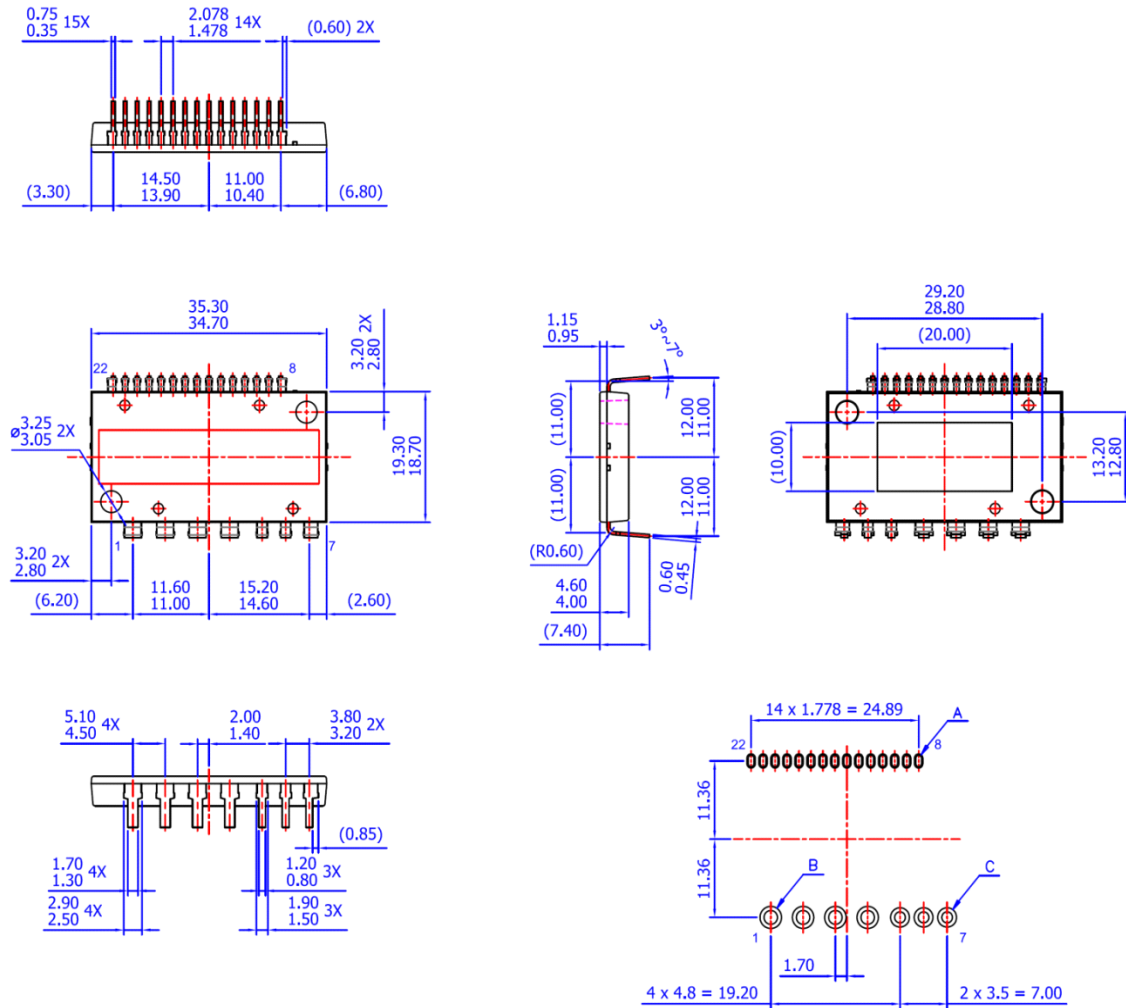

Figure 8. Typical Application Circuit

2nd Notes:

1. To avoid malfunction, the wiring of each input should be as short as possible (less than 2-3 cm).
2. VFO output is open-drain type. This signal line should be pulled up to the positive side of the MCU or control power supply with a resistor that makes IFO up to 1 mA.
3. Input signal is active-HIGH type. There is a 5 kΩ resistor inside the IC to pull-down each input signal line to GND. RC coupling circuits is recommended for the prevention of input signal oscillation. R_FC_F constant should be selected in the range 50 ~ 150 ns (recommended R_S = 100 Ω , C_{PS} = 1 nF).
4. Each capacitors should be mounted as close to the Motion SPM® module pins as possible.
5. The zener diode should be adopted for the protection of ICs from the surge destruction between each pair of control supply terminals(recommended zener diode = 24 V / 1 W).

Detailed Package Outline Drawing



- NOTES: UNLESS OTHERWISE SPECIFIED
- A) THIS PACKAGE DOES NOT COMPLY TO ANY CURRENT PACKAGING STANDARD
 - B) ALL DIMENSIONS ARE IN MILLIMETERS
 - C) DIMENSIONS ARE EXCLUSIVE OF BURRS, MOLD FLASH, AND TIE BAR EXTRUSIONS
 - D) () IS REFERENCE
 - E) [] IS ASS'Y QUALITY
 - F) DRAWING FILENAME: MOD22AAREV1.0
 - G) FAIRCHILD SEMICONDUCTOR

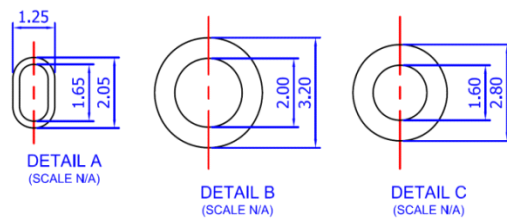

Package drawings are provided as a service to customers considering Fairchild components. Drawings may change in any manner without notice. Please note the revision and/or data on the drawing and contact a FairchildSemiconductor representative to verify or obtain the most recent revision. Package specifications do not expand the terms of Fairchild's worldwide terms and conditions, specifically the the warranty therein, which covers Fairchild products.





Always visit Fairchild Semiconductor's online packaging area for the most recent package drawings:

<http://www.fairchildsemi.com/dwg/MO/MOD22AA.pdf>



TRADEMARKS

The following includes registered and unregistered trademarks and service marks, owned by Fairchild Semiconductor and/or its global subsidiaries, and is not intended to be an exhaustive list of all such trademarks.

- | | | | |
|---|--|---|---|
| AccuPower™ | F-PFS™ |  | Sync-Lock™ |
| AX-CAP®* | FRFET® | PowerTrench® |  SYSTEM GENERAL® |
| BitSiC™ | Global Power Resource™ | PowerXS™ | TinyBoost® |
| Build it Now™ | GreenBridge™ | Programmable Active Droop™ | TinyBuck® |
| CorePLUS™ | Green FPS™ | QFET® | TinyCalc™ |
| CorePOWER™ | Green FPS™ e-Series™ | QS™ | TinyLogic® |
| CROSSVOLT™ | Gmax™ | Quiet Series™ | TINYOPTO™ |
| CTL™ | GTO™ | RapidConfigure™ | TinyPower™ |
| Current Transfer Logic™ | IntelliMAX™ |  | TinyPWM™ |
| DEUXPEED® | ISOPLANAR™ | Saving our world, 1mW/W/kW at a time™ | TinyWire™ |
| Dual Cool™ | Making Small Speakers Sound Louder and Better™ | SignalWise™ | TranSiC™ |
| EcoSPARK® | MegaBuck™ | SmartMax™ | TriFault Detect™ |
| EfficientMax™ | MICROCOUPLER™ | SMART START™ | TRUECURRENT®* |
| ESBC™ | MicroFET™ | Solutions for Your Success™ | µSerDes™ |
|  | MicroPak™ | SPM® |  |
| Fairchild® | MicroPak2™ | STEALTH™ | UHC® |
| Fairchild Semiconductor® | MillerDrive™ | SuperFET® | Ultra FRFET™ |
| FACT Quiet Series™ | MotionMax™ | SuperSOT™-3 | UniFET™ |
| FACT® | mWSaver® | SuperSOT™-6 | VCX™ |
| FAST® | OptoHiT™ | SuperSOT™-8 | VisualMax™ |
| FastvCore™ | OPTOLOGIC® | SupreMOS® | VoltagePlus™ |
| FETBench™ | OPTOPLANAR® | SyncFET™ | XS™ |
| FPS™ | | | |

* Trademarks of System General Corporation, used under license by Fairchild Semiconductor.

DISCLAIMER

FAIRCHILD SEMICONDUCTOR RESERVES THE RIGHT TO MAKE CHANGES WITHOUT FURTHER NOTICE TO ANY PRODUCTS HEREIN TO IMPROVE RELIABILITY, FUNCTION, OR DESIGN. FAIRCHILD DOES NOT ASSUME ANY LIABILITY ARISING OUT OF THE APPLICATION OR USE OF ANY PRODUCT OR CIRCUIT DESCRIBED HEREIN; NEITHER DOES IT CONVEY ANY LICENSE UNDER ITS PATENT RIGHTS, NOR THE RIGHTS OF OTHERS. THESE SPECIFICATIONS DO NOT EXPAND THE TERMS OF FAIRCHILD'S WORLDWIDE TERMS AND CONDITIONS, SPECIFICALLY THE WARRANTY THEREIN, WHICH COVERS THESE PRODUCTS.

LIFE SUPPORT POLICY

FAIRCHILD'S PRODUCTS ARE NOT AUTHORIZED FOR USE AS CRITICAL COMPONENTS IN LIFE SUPPORT DEVICES OR SYSTEMS WITHOUT THE EXPRESS WRITTEN APPROVAL OF FAIRCHILD SEMICONDUCTOR CORPORATION.

As used herein:

1. Life support devices or systems are devices or systems which, (a) are intended for surgical implant into the body or (b) support or sustain life, and (c) whose failure to perform when properly used in accordance with instructions for use provided in the labeling, can be reasonably expected to result in a significant injury of the user.
2. A critical component in any component of a life support, device, or system whose failure to perform can be reasonably expected to cause the failure of the life support device or system, or to affect its safety or effectiveness.

ANTI-COUNTERFEITING POLICY

Fairchild Semiconductor Corporation's Anti-Counterfeiting Policy. Fairchild's Anti-Counterfeiting Policy is also stated on our external website, www.fairchildsemi.com, under Sales Support.

Counterfeiting of semiconductor parts is a growing problem in the industry. All manufacturers of semiconductor products are experiencing counterfeiting of their parts. Customers who inadvertently purchase counterfeit parts experience many problems such as loss of brand reputation, substandard performance, failed applications, and increased cost of production and manufacturing delays. Fairchild is taking strong measures to protect ourselves and our customers from the proliferation of counterfeit parts. Fairchild strongly encourages customers to purchase Fairchild parts either directly from Fairchild or from Authorized Fairchild Distributors who are listed by country on our web page cited above. Products customers buy either from Fairchild directly or from Authorized Fairchild Distributors are genuine parts, have full traceability, meet Fairchild's quality standards for handling and storage and provide access to Fairchild's full range of up-to-date technical and product information. Fairchild and our Authorized Distributors will stand behind all warranties and will appropriately address any warranty issues that may arise. Fairchild will not provide any warranty coverage or other assistance for parts bought from Unauthorized Sources. Fairchild is committed to combat this global problem and encourage our customers to do their part in stopping this practice by buying direct or from authorized distributors.

PRODUCT STATUS DEFINITIONS

Definition of Terms

Datasheet Identification	Product Status	Definition
Advance Information	Formative / In Design	Datasheet contains the design specifications for product development. Specifications may change in any manner without notice.
Preliminary	First Production	Datasheet contains preliminary data; supplementary data will be published at a later date. Fairchild Semiconductor reserves the right to make changes at any time without notice to improve design.
No Identification Needed	Full Production	Datasheet contains final specifications. Fairchild Semiconductor reserves the right to make changes at any time without notice to improve the design.
Obsolete	Not In Production	Datasheet contains specifications on a product that is discontinued by Fairchild Semiconductor. The datasheet is for reference information only.

Rev. 166

AMEYA360

Components Supply Platform

Authorized Distribution Brand :



Website :

Welcome to visit www.ameya360.com

Contact Us :

➤ Address :

401 Building No.5, JiuGe Business Center, Lane 2301, Yishan Rd
Minhang District, Shanghai , China

➤ Sales :

Direct +86 (21) 6401-6692

Email amall@ameya360.com

QQ 800077892

Skype [ameyasales1](#) [ameyasales2](#)

➤ Customer Service :

Email service@ameya360.com

➤ Partnership :

Tel +86 (21) 64016692-8333

Email mkt@ameya360.com