

FAN7554

Versatile PWM Controller

Features

- Current mode control
- Pulse by pulse current limiting
- Low external components
- Under voltage lockout(UVLO): 9V/15V
- Stand-by current: typ. 100uA
- Power saving mode current: typ. 200uA
- Operating current: typ. 7mA
- Soft start
- On/off control
- Over load protection(OLP)
- Over voltage protection(OVP)
- Over current protection(OCP)
- Over current limit(OCL)
- Operating frequency up to 500kHz
- 1A totem-pole output current

Applications

- Off-Line & DC-DC converter

Description

The FAN7554 is a fixed frequency current mode PWM controller. It is specially designed for off-line and DC to DC converter applications with minimal external components. These integrated circuits feature a trimmed oscillator for precise duty cycle control, a temperature compensated reference, an ON/OFF control, a high gain error amplifier, a current sensing comparator, and a high current totem-pole output. The FAN7554 has various protection functions such as an over load protection, an over current protection, and the over voltage protection, which include built-in auto restart circuit. The FAN7554 is available in the 8-DIP package as well as the 8-SOP package.

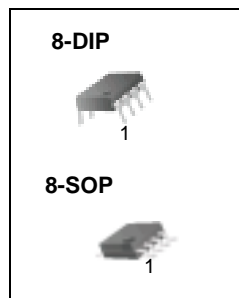

Temperature Characteristics

($-25^{\circ}\text{C} \leq T_a \leq 85^{\circ}\text{C}$)

Parameter	Symbol	Value	Unit
Vref temperature stability	ΔV_{REF3}	± 0.5	%
Fosc temperature stability	ΔF_{OSC2}	± 5	%

PIN Array

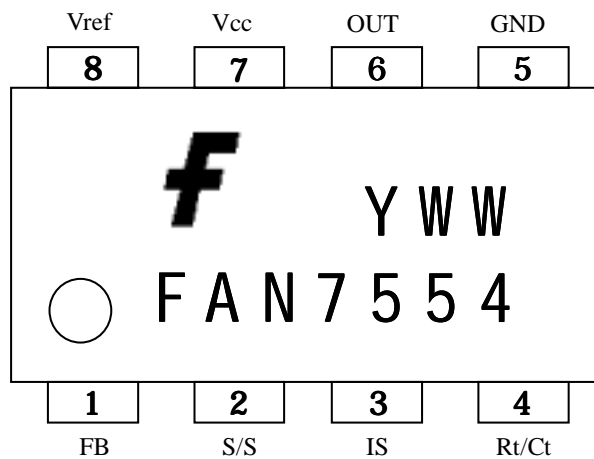

PIN Definitions

Pin Number	Pin Name	Pin Function Description
1	FB	Inverting(-) input of pwm comparator, on/off control & OLP sensing terminal.
2	S/S	Soft start
3	IS	Non-inverting(+) input of PWM comparator, OCL sensing terminal
4	Rt/Ct	Oscillator time constant(Rt/Ct)
5	GND	Ground
6	OUT	Output of gate driver
7	Vcc	Power supply
8	Vref	Output of 5V reference

Electrical Characteristics

($T_a = 25^\circ\text{C}$, $V_{CC} = 16\text{V}$, $R_t = 10\text{k}\Omega$, $C_t = 3.3\text{nF}$ unless otherwise specified)

Parameter	Symbol	Conditions	Min.	Typ.	Max.	Unit
< REFERENCE SECTION >						
Reference output voltage	V_{REF}	$T_j = 25^\circ\text{C}$, $I_{ref} = 1\text{mA}$	4.90	5.00	5.10	V
Line regulation	ΔV_{REF1}	$V_{CC} = 12\text{V} \sim 25\text{V}$	-	6	20	mV
Load regulation	ΔV_{REF2}	$I_{ref} = 1\text{mA} \sim 20\text{mA}$	-	6	25	mV
Short circuit output current	I_{SC}	$T_j = 25^\circ\text{C}$	-	0.1	0.18	A
< OSCILLATOR SECTION >						
Oscillation frequency	F_{OSC}	$T_j = 25^\circ\text{C}$	45	50	55	kHz
Frequency change with V_{CC}	ΔF_{OSC1}	$V_{CC} = 12\text{V} \sim 25\text{V}$	-	0.05	1.0	%
Ramp high voltage	V_{RH}	-	-	2.8	-	V
Ramp low voltage	V_{RL}	-	-	1.2	-	V
Discharge current	I_{disch}	$V_{RT}/C_T = 3.3\text{V}$	6.1	-	9.4	mA
< PWM SECTION >						
Sense threshold voltage	$V_{TH(IS)}$	$V_{FB} = 5\text{V}$	0.8	1.0	1.2	V
Feedback threshold voltage	$V_{TH(FB)}$	$V_{IS} = 0\text{V}$	0.2	0.3	0.4	V
Feedback source current	I_{FB}	$V_{FB} = 0\text{V}$, $V_{S/S} = 5\text{V}$	-	1.0	-	mA
Max. duty cycle	$D(\text{MAX})$	-	92	95	98	%
Min. duty cycle	$D(\text{MIN})$	-	-	-	0	%
< PROTECTION SECTION >						
Shutdown delay current	I_{SD}	$4\text{V} \leq V_{FB} \leq V_{SD}$	3.5	5	6.5	μA
Shutdown feedback voltage	V_{SD}	$V_{FB} > 5\text{V}$	5.4	6	6.6	V
Over current protection	V_{OC}	$V_{IS} > 1.5\text{V}$, $t_{on} > 500\text{nS}$	1.6	2	2.4	V
Over voltage protection	V_{OVP}	-	30	34	38	V
< ON/OFF CONTROL SECTION >						
Off mode sink current	I_{SINK}	$V_{FB} < V_{TH(FB)}$, $V_{S/S} = 5\text{V}$	-	4	-	mA
Off threshold voltage	V_{OFF}	$V_{FB} < V_{TH(FB)}$	1.2	1.5	1.8	V
< SOFT-START SECTION >						
Soft start current	$I_{S/S}$	$V_{FB} = 5\text{V}$, $V_{S/S} = 0\text{V}$	-	1.1	-	mA
Soft start limit voltage	$V_{LIM(S/S)}$	$V_{CC} = 16\text{V}$	-	5.2	-	V
< OUTPUT SECTION >						
Low output voltage1	V_{OL1}	$V_{CC} = 18\text{V}$, $I_O = 50\text{mA}$	-	0.15	0.4	V
High output voltage1	V_{OH1}	$V_{CC} = 18\text{V}$, $I_O = -50\text{mA}$	13	15	17	V
Low output voltage2	V_{OL2}	$V_{CC} = 18\text{V}$, $I_O = 200\text{mA}$	-	1.5	2.5	V
High output voltage2	V_{OH2}	$V_{CC} = 18\text{V}$, $I_O = -200\text{mA}$	12	14	16	V
Rising time (Note1)	t_R	$T_j = 25^\circ\text{C}$, $C_L = 1\text{nF}$	-	80	-	ns
Falling time (Note1)	t_F	$T_j = 25^\circ\text{C}$, $C_L = 1\text{nF}$	-	40	-	ns
< UVLO SECTION >						
Start threshold voltage	$V_{TH(ST)}$	-	13.2	15	16.2	V
Min. operating voltage	$V_{OPR(M)}$	-	8.2	9	10.2	V

Electrical Characteristics (Continued)

($T_a = 25^\circ\text{C}$, $V_{cc}=16\text{V}$, $R_t = 10\text{k}\Omega$, $C_t = 3.3\text{nF}$ unless otherwise specified)

Parameter	Symbol	Conditions	Min.	Typ.	Max.	Unit
<TOTAL STAND-BY CURRENT SECTION>						
Start-up current	I _{ST}	-	-	0.1	0.2	mA
Operating supply current	I _{OP}	-	-	7	10	mA
Off State current	I _{OFF}	$V_{FB} < V_{TH(FB)}, V_{S/S} < V_{OFF}$	-	0.2	0.4	mA

Note:

1. These parameters, although guaranteed, are not 100% tested in production.

Typical Performance Characteristics

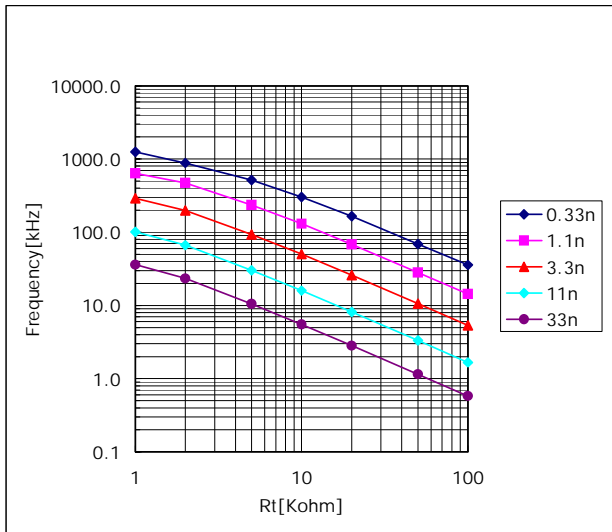

Figure 1. Rt vs. Frequency

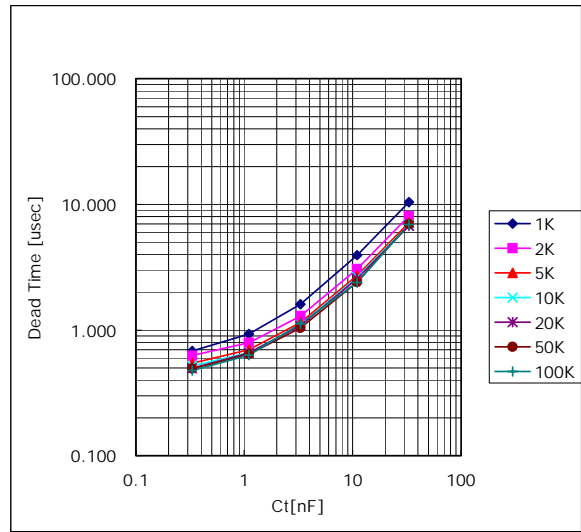

Figure 2. Ct vs. Dead Time

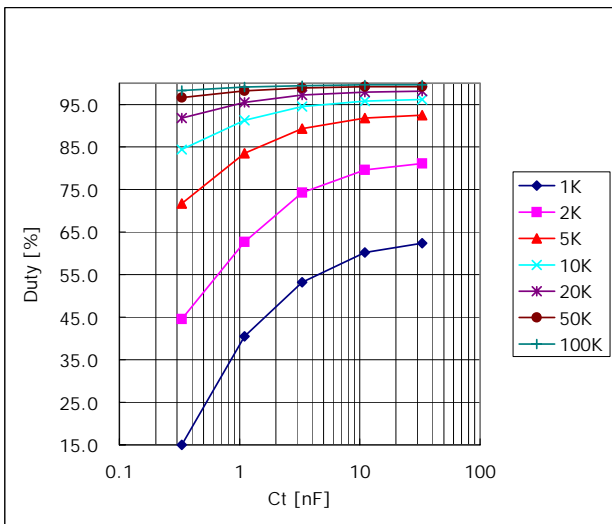

Figure 3. Ct vs. Duty

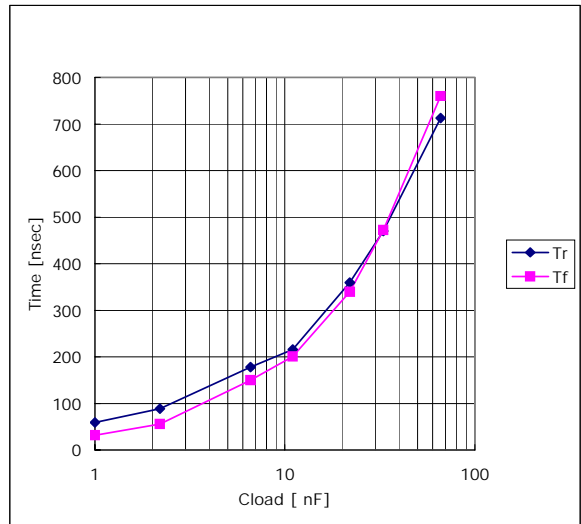

Figure 4. Cloud vs. Tr & Tf

Typical Performance Characteristics(Continued)

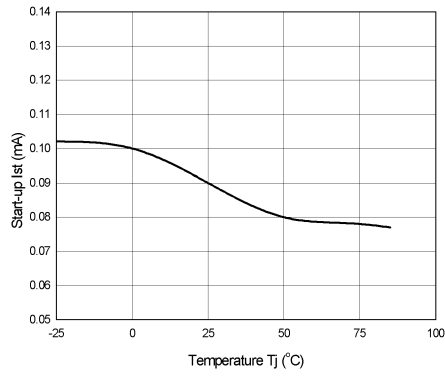

Figure 5. Temperature vs. Start-up Current

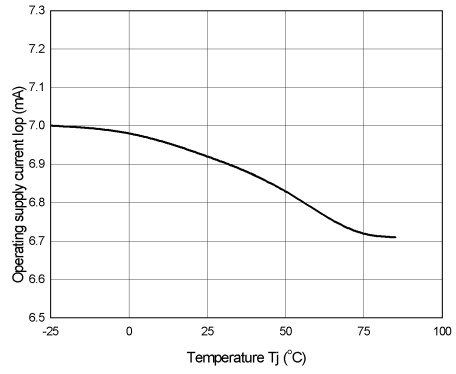

Figure 6. Temperature vs. Operating Supply Current

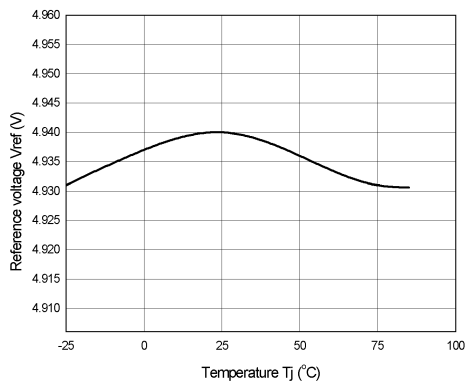

Figure 7. Temperature vs. Reference Voltage

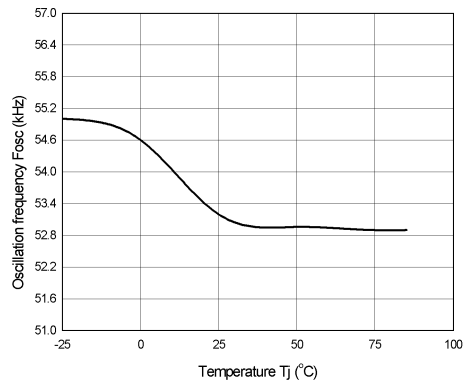

Figure 8. Temperature vs. Oscillation frequency

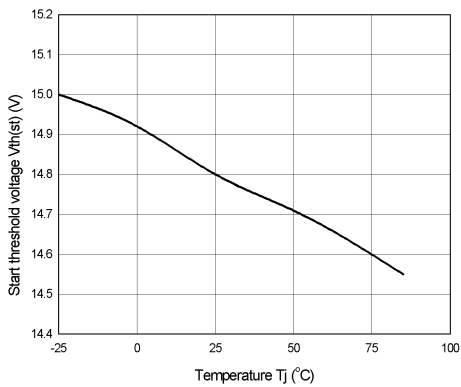

Figure 9. Temperature vs. Start Threshold Voltage

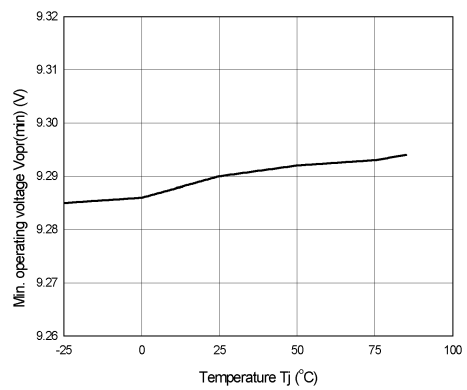

Figure 10. Temperature vs. Min. Operating Voltage

Operation Description

The FAN7554 has all the basic features of the current mode SMPS control IC. Its basic configuration includes the UVLO with 6V hysteresis, a band gap reference, the oscillator that can oscillate up to 500kHz according to R_f/C_t (connected externally), a PWM logic circuit, a gate driver, and the feedback circuit that has the current source and soft start function. The FAN7554 has various functions such as an over load protection, an over current protection, and an over voltage protection. The over load protection forces the FAN7554 to stop its operation if the load current is higher than the preset value. The protection circuit can also be prevented from operating during transient states by ensuring that a certain amount of the time passes before the protection circuit operates. The shutdown circuit is configured for an auto-restart, so the FAN7554 automatically restarts when V_{cc} drops to 9V (stop voltage).

Start-Up

The start-up circuit is made up of an under voltage lock out (UVLO), the protection for low voltage conditions, and the 5V reference (V_{ref}), which supplies bias voltage to the control circuit after start-up. The start voltage of the UVLO is 15V, and the stop voltage after turn on is 9V. It has a 6V hysteresis. The minimum operating current for start-up threshold is typically 100uA, and this can reduce the power dissipation on the start-up resistor. The V_{ref} is composed of the band gap reference circuit with its superior temperature characteristics and supplies power to all the FAN7554 circuits and R_f/C_t , with the exceptions of the ULVO circuit and ON/OFF control circuit.

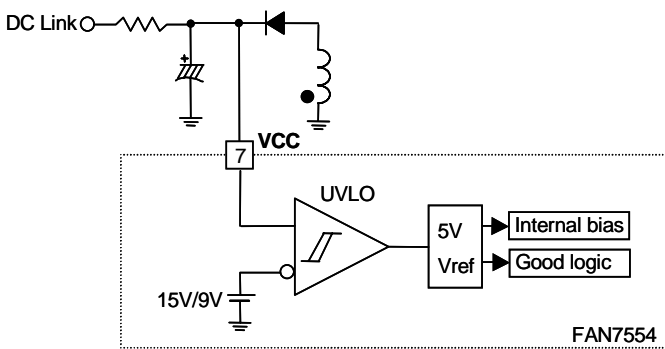

Figure 11. Low Current Start-Up & Bandgap Reference Circuit

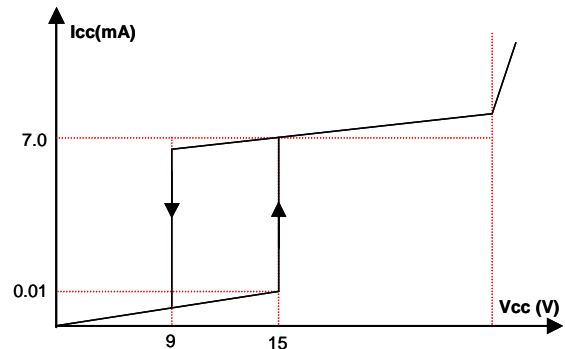

Figure 12. Start-Up & Circuit Characteristics

Soft Start

The SMPS output load usually contains a capacitive load component. During initial start-up, the output voltage increases at a fixed time constant because of this component. If the feedback loop, which controls the output voltage, was to start without the soft start circuit, the feedback loop would appear to be open during initial start-up, so, at start-up, the feedback voltage applied to the PWM comparator's inverting input (-) reaches its maximum value (1V).

During this time, the peak value of the drain current would stay at the maximum value, and the maximum power would be delivered to the secondary load side from the start. When the maximum power is delivered to the secondary side for this initial fixed time, the entire circuit is seriously stressed. The use of a soft start can avoid such stresses. At start-up, the soft start capacitor C_s is charged by 1mA and 100uA current sources.

The voltage of the inverting terminal of the PWM comparator increases to 1/3 of the C_s voltage at a fixed time constant. Subsequently, the drain peak current is limited by the gradual increase in the C_s voltage and this causes the output voltage to increase smoothly. When the C_s voltage becomes greater than 3V, the diode D_s turns off consequently, the feedback capacitor C_{fb} is charged by 1mA and 5uA current sources. This charge voltage determines the comparator's inverting voltage. Then, C_s voltage charges to 5V by 100uA current source. The soft start capacitor C_s is discharged when the UVLO good logic starts, so the soft start is repeated at re-start.

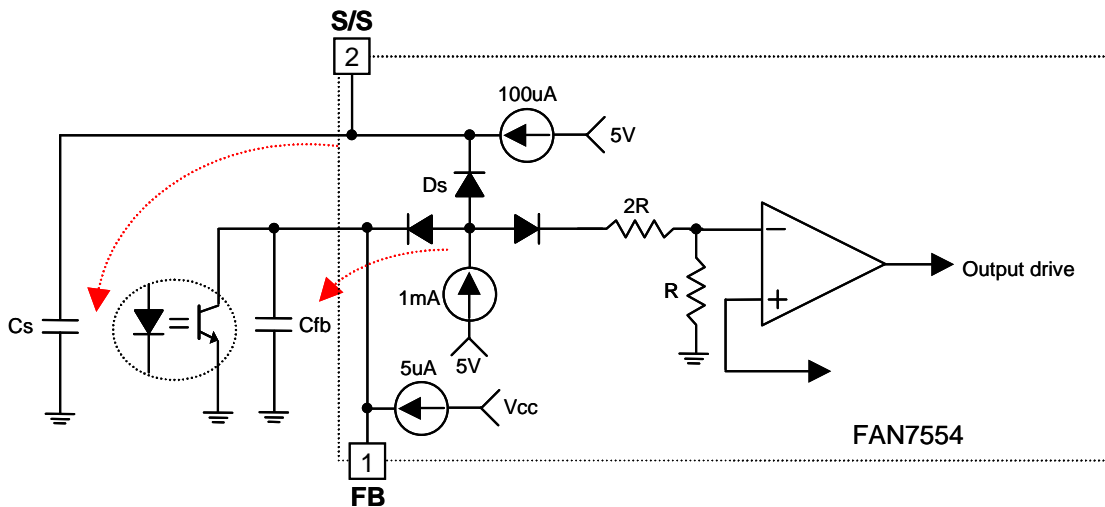

Figure 13. Soft Start Circuit & Circuit Flow

Oscillator

As shown in figure14, the oscillator frequency is programmed by values selected for timing components R_t and C_t . Capacitor C_t is charged to almost 2.8V through resistor R_t from the 5V reference and discharged to 1.2V by an internal current source. The oscillator generates the clock signal while the timing capacitor C_t is discharged. The gate drive output becomes low during the clock time. R_t and C_t selection determine the oscillator frequency and maximum duty cycle. Charge and discharge times can be calculated through the equations below.

$$\text{Charging time : } t_c = 0.55 \times R_t \times C_t$$

$$\text{Discharging time : } t_d = R_t \times C_t \times \ln[(0.0063 \times R_t - 2.8) / (0.0063 \times R_t - 3.8)]$$

$$\text{where the oscillator frequency : } f_{osc} = (t_c + t_d)^{-1} (\pm 10\%)$$

$$\text{When } R_t > 5k\Omega, f_{osc} = 1 / (0.55 \times R_t \times C_t) = 1.8 / (R_t \times C_t)$$

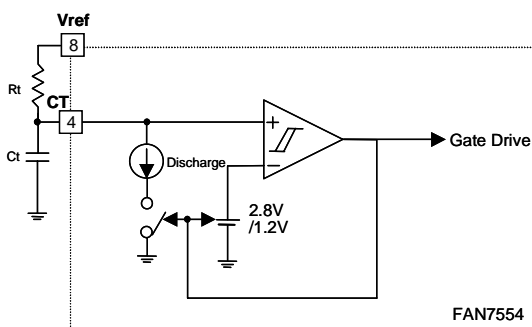

Figure 14. Oscillator Circuit

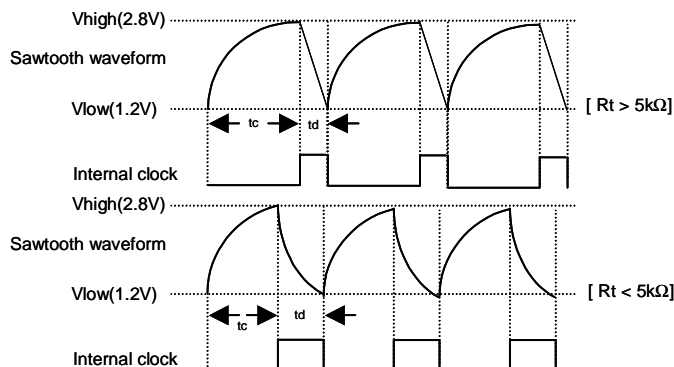

Figure 15. Sawtooth & Clock Waveform

Feedback

As shown in figure16, the internal oscillator clock turns on the MOSFET. The feedback comparator operates to turn it off again, when the MOSFET current reaches a set value proportional to Vfb. The feedback capacitor Cfb is charged by the internal current sources , 1mA and 5uA, and is discharged by the secondary side photo-coupler to control the output voltage.

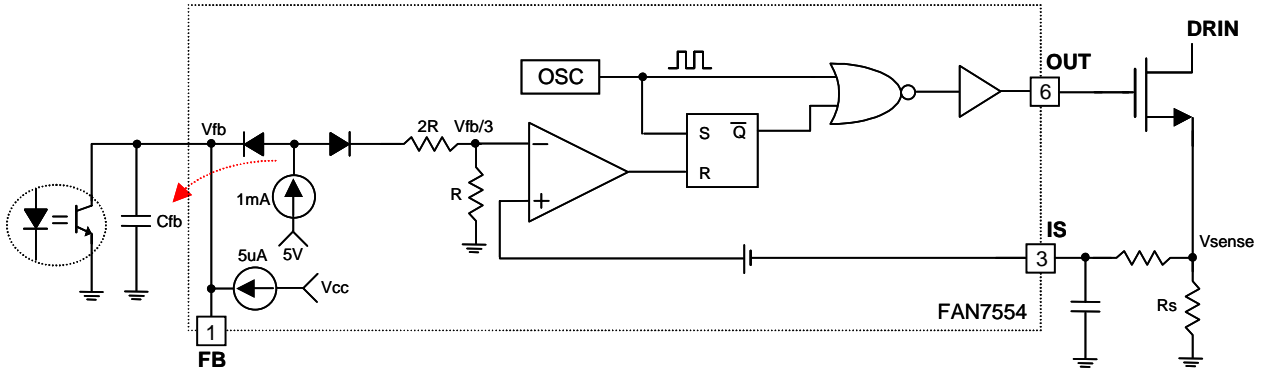

Figure 16. Feedback & PWM Circuit

Delayed Shutdown

During the normal operation, the feedback voltage is between 0~3V. If the output terminal overloads or an error happens to the feedback loop, the delayed shutdown circuit operates. When the feedback voltage is less than 3V, the feedback capacitor is charged by current sources, 1mA and 5uA; when the feedback voltage becomes greater than 3V, the capacitor is charged by the 5uA current source because diode D1 turns off. When the feedback voltage is less than 3V, the charge slope becomes an exponential function and, when it is greater than 3V, the charge slope becomes linear. When the feedback voltage reaches almost 6V, the FAN7554 shuts down. The shut down circuit is configured for auto-restart, so it automatically restarts when Vcc reaches the under voltage 9V.

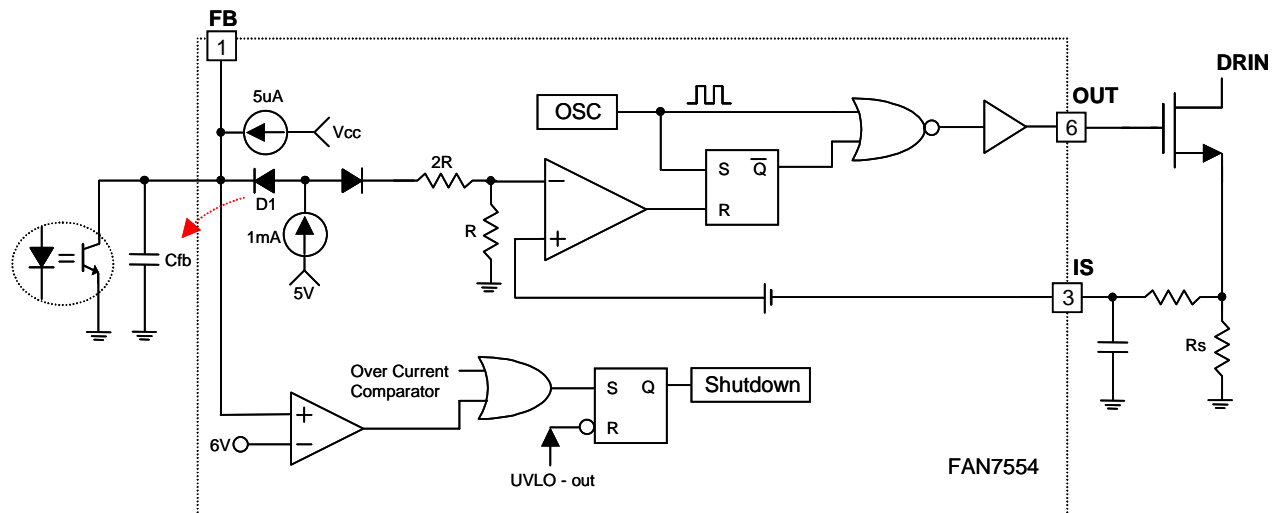

Figure 17-A . Delayed Shutdown & Feedback Circuit

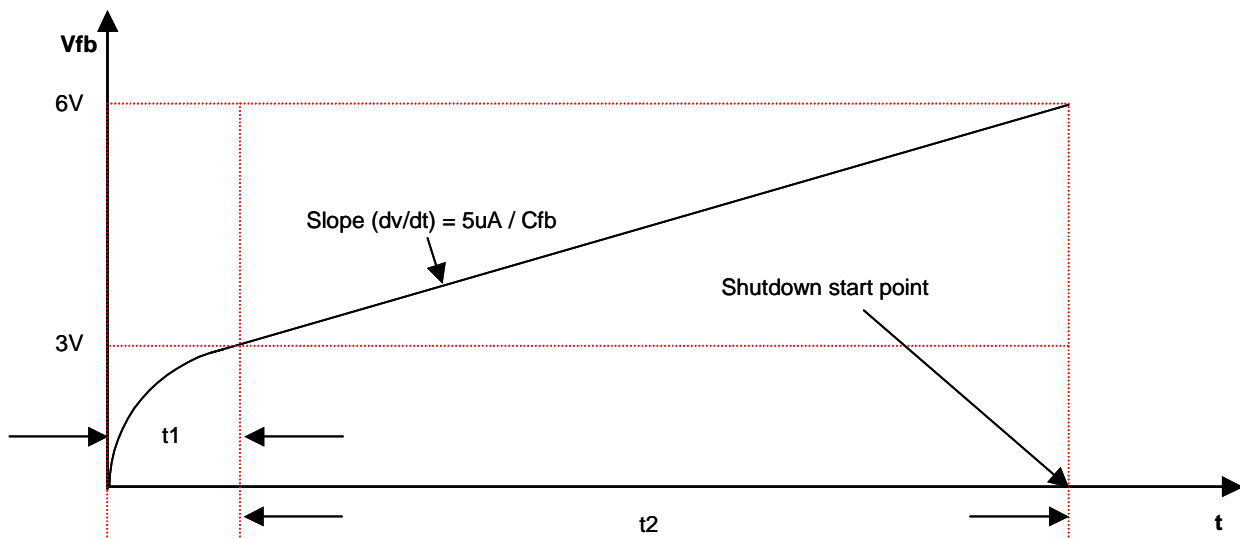

Figure 17-B . Delayed Shutdown & Feedback Waveform

Gate Driver

The gate drive circuit has the totem-pole output configuration. The output has 1A peak current and 200mA average current drive ability.

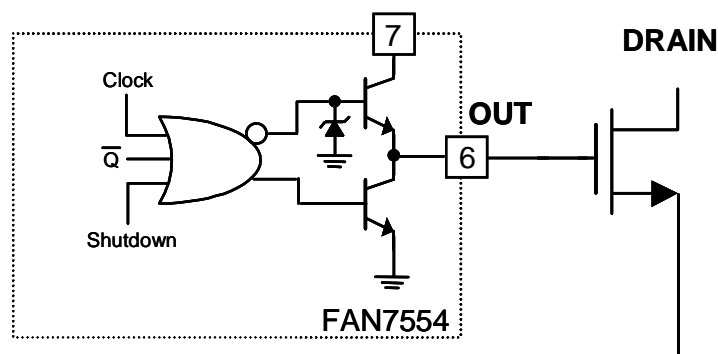

Figure 18. Gate Drive Circuit

ON/OFF Control

The FAN7554 is able to use the feedback pin for ON/OFF control by placing NPN transistor between the cathode of the KA431 and ground as shown in figure 19. When the transistor turns on, the current flows through the photo diode and saturates the photo transistor. As a result, the feedback voltage is dropped to zero. When the feedback voltage is below 0.3V, the soft start voltage starts to discharge by connecting the internal resistor 1k Ω in parallel with the external capacitor Cs. When the soft start voltage becomes less than 1.5V, all the blocks in the FAN7554 are turned off, with the exceptions of the UVLO block and ON/OFF control block. The operation current is about 200 μ A. So the stand-by power is reduced and SMPS efficiency is improved. When the feedback voltage exceeds 0.3V, the FAN7554 normally operates by turning on Vref block.

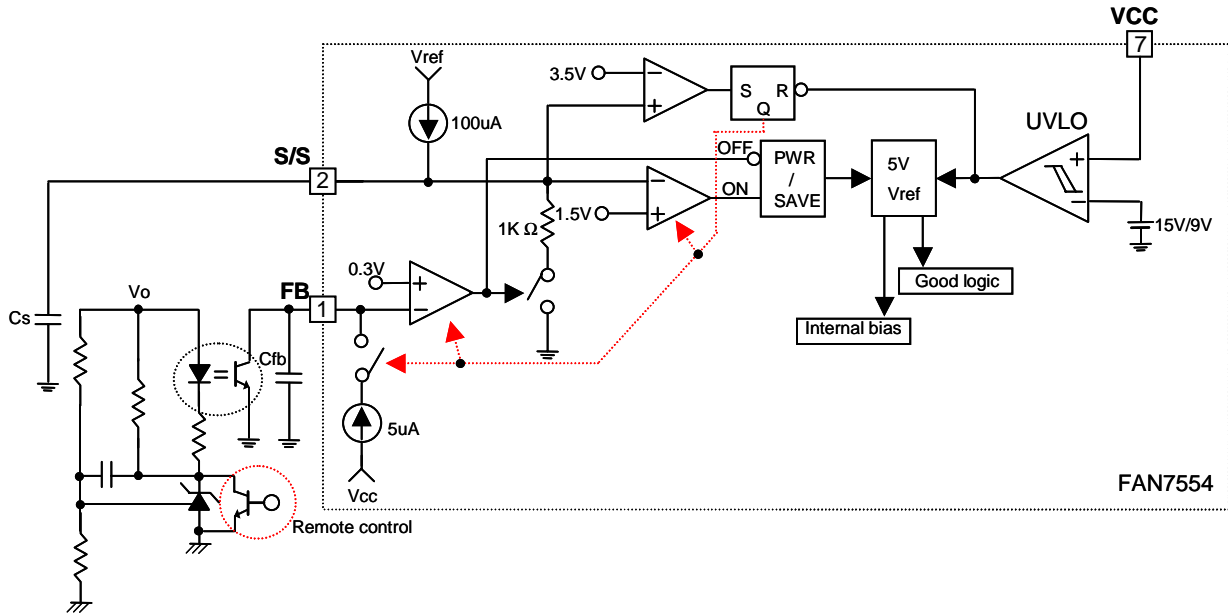

Figure 19. ON/OFF Control Circuit

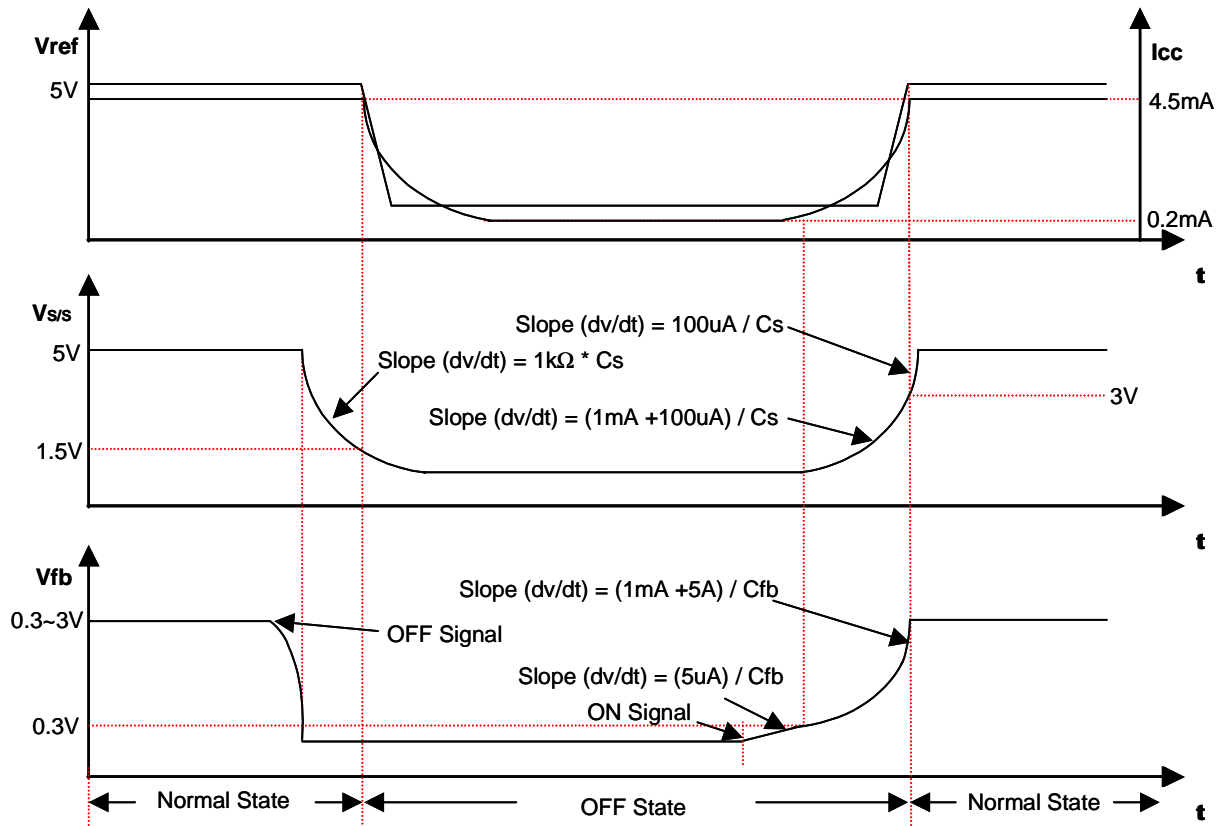

Figure 20. ON-OFF Control Circuit Waveforms

Protection Circuits

The FAN7554 has many built-in protection circuits that do not need additional components, providing reliability without cost increase. These protection circuits have the auto-restart configuration. In this configuration, the protection circuits reset when Vcc is below UVLO stop threshold (9V) and restarts when Vcc is above UVLO start threshold voltage (15V)

Over Voltage Protection

Abnormalities may occur in the SMPS secondary side feedback circuit. First, when the feedback pin is short to the ground, the feedback voltage is zero and the FAN7554 is unable to start switching. Second, when the feedback circuit is open, the secondary voltage generally becomes much greater than the rated voltage as the primary side continues to switch at the maximum current level. This may cause the blowing off the fuse or, in serious cases, fires. It is possible that the devices directly connected to the secondary output without a regulator could be destroyed. Even in these cases, the over voltage protection circuit operates. Since Vcc is proportional to the output, in an over voltage situation, it also will increase. In the FAN7554, the protection circuit operates when Vcc exceeds 34V. Therefore, in normal operation, Vcc must be set below 34V.

Over Load Protection

An overload is the state in which the load is operating normally but in excess of the preset load. The overload protection circuit can force the FAN7554 to stop its operation. The protection can also operate in transient states such as initial SMPS operation. Because the transient state returns to the normal state after a fixed time, the protection circuit need not to operate during this time. That is, the FAN7554 needs the time to detect and decide whether it is an overload condition or not. The protection circuit can be prevented from operating during transient states by ensuring that a certain amount of time passes before the protection circuit operates. The above operations are executed as follows: Since the FAN7554 adopts a current mode, it is impossible for current to flow above a maximum level. For a fixed input voltage, this limits power. Therefore, if the power at the output exceeds this maximum, Vo, shown in figure21, becomes less than the set voltage, and the KA431 pulls in only the given minimum current. As a result, the photo-coupler's secondary side current becomes zero. The same goes for the photo-coupler's primary side current. Consequently, when the full current 1mA flows through the internal resistor (2R + R = 3R), Vfb becomes approximately 3V and from that time, the 5uA current source begins to charge Cfb, the photo-coupler's secondary current is almost zero. The FAN7554 shuts down when Vfb reaches 6V.

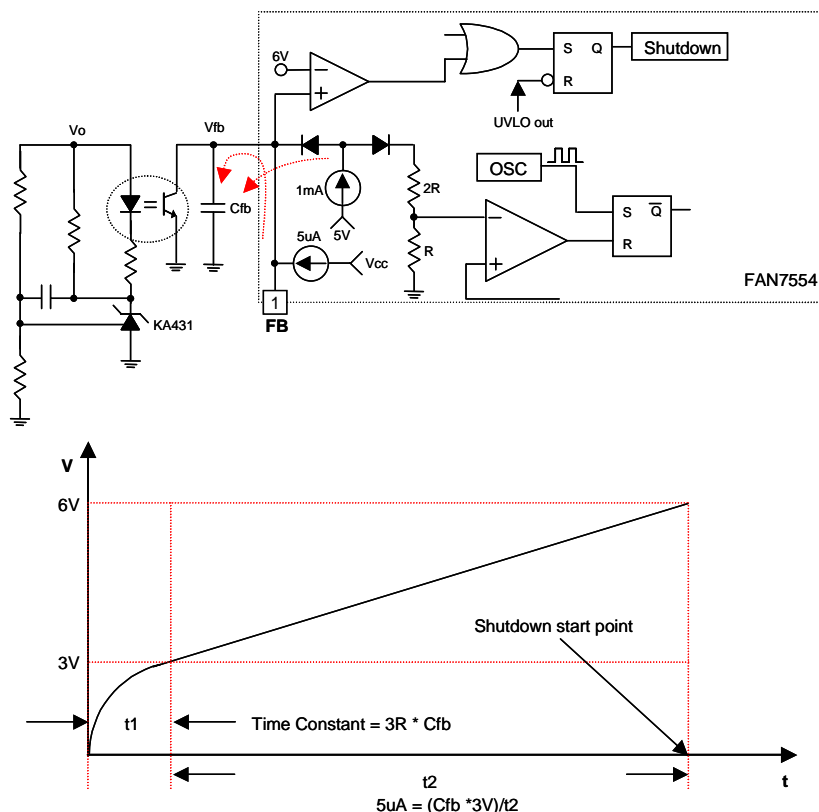

Figure 21. Delayed Shutdown

Part List For FAN7554 Flyback Converter Demo Board

Part	Value	Note	Part	Value	Note
FUSE			CAPACITOR		
FUSE	250 2A	-	C101	100nF/ 275V	Box Capacitor
NTC			C102	100nF/ 275V	Box Capacitor
NTC	5D-11	-	C103	470nF/ 400WV	Electrolytic
RESISTOR			C104	103/ 1kV	Film Capacitor
R101	330k Ω	1W	C105	104	Ceramic
R102	-	-	C106	1uF/ 10V	Electrolytic
R103, R104	100k Ω	1W	C107	101	Ceramic
R105	22 Ω	-	C108	122	Ceramic
R106	4.7k Ω	-	C109	22uF/ 50V	Electrolytic
R107	12k Ω	-	C201	330uF	Electrolytic
R108	10 Ω	-	C202	330uF	Electrolytic
R109	1k Ω	-	C203	104	Ceramic
R110	0.5 Ω	2W	C301	-	-
R201	1k Ω	-	C302	-	-
R202	1k Ω	-			
R203	4.7k Ω	-	INDUCTOR		
R204	1.2k Ω	-	LF101	30mH	-
R205	-	-	L201	6.4uH	-
MOSFET			DIODE		
Q101	FQP6N70	Fairchild	D201	MBRF10100CT	-
IC			D101	UF4007	Fairchild
IC101	FAN7554	Fairchild	D102	1N4148	-
IC201	KA431	Fairchild	D103	UF4004	Fairchild
IC301	Opto-coupler	Fairchild	BD	G3SBA60	-

Transformer Specification

Schematic Diagram (Top view)

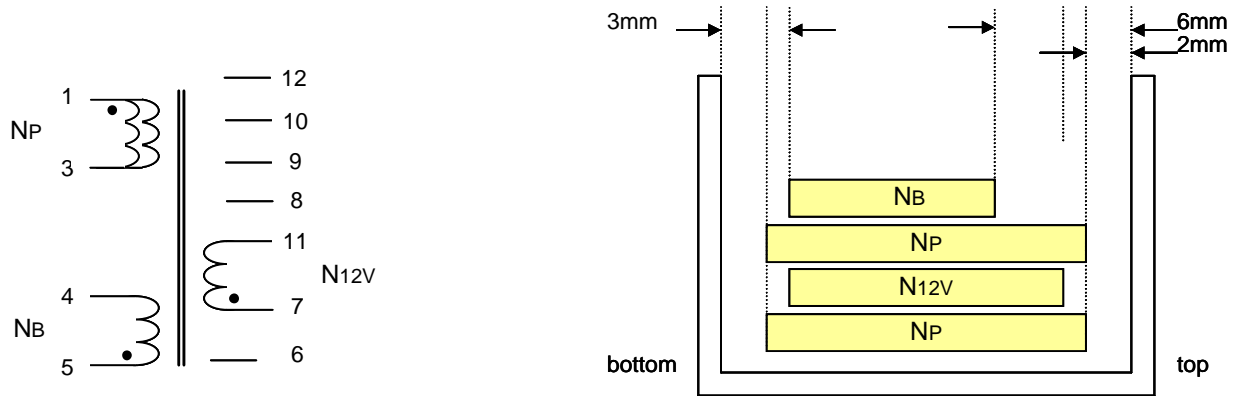

Winding Specification

No.	Pin(S → F)	Wire	Turns	Winding Method
NP	1 → 3	0.35φ × 1	44	-
N12V	7 → 11	0.35φ × 4	12	-
NP	1 → 3	0.35φ × 1	44	-
NB	5 → 4	0.35φ × 1	13	-

Electrical Characteristic

Closure	Pin	Spec.	Remarks
Inductance	1 - 3	400uH ±10%	100kHz, 1V
Leakage	1 - 3	10uH MAX .	2 nd All short

FAN7554 forward converter demo circuit (fsw:100kHz)

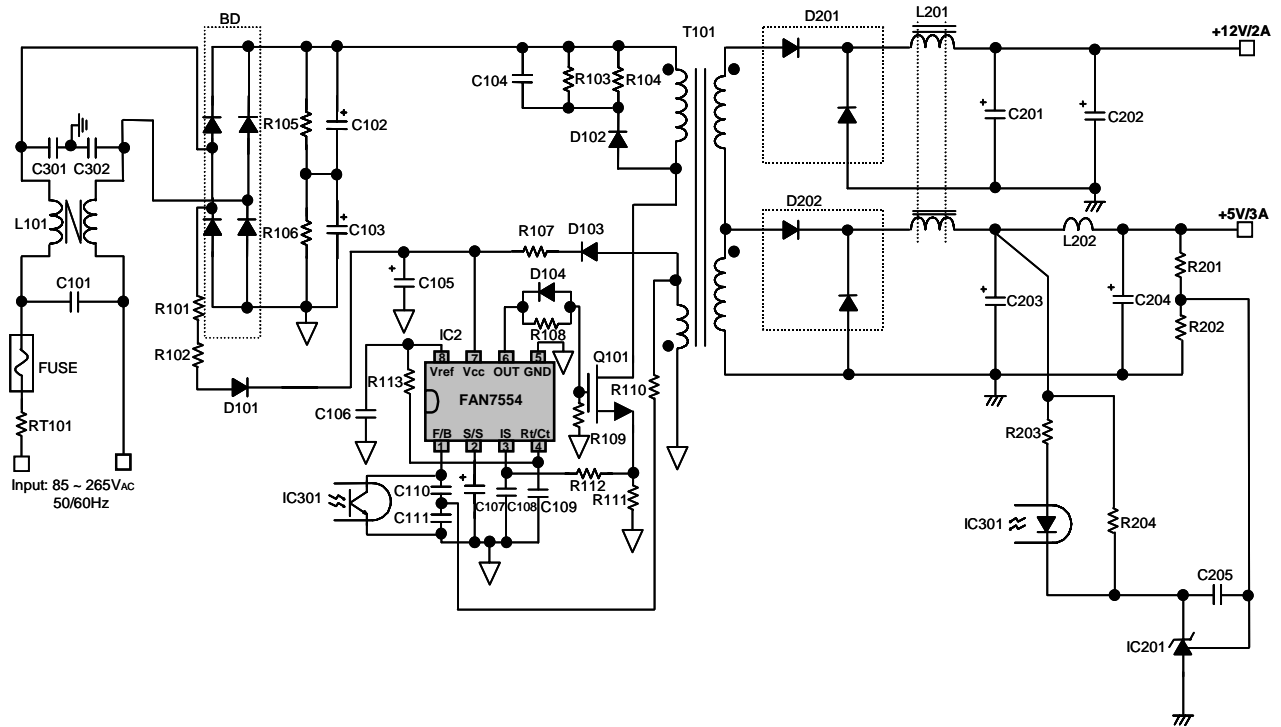

Part List For FAN7554 Forward Converter Demo Board

Part	Value	Note	Part	Value	Note
FUSE			CAPACITOR		
FUSE	250 2A	-	C101	470nF/ 275V	Box Capacitor
NTC			C102, C103	470nF/ 400WV	Electrolytic
RT101	DSC 10D-11	-	C104	223/ 630V	Film
RESISTOR			C105	33uF/ 35V	Film Capacitor
R101	330k Ω	1W	C106	104	Ceramic
R102	-	-	C107	1uF/ 35V	Electrolytic
R103, R104	56k Ω	1W	C108	101	Ceramic
R105, R106	220k Ω	1W	C109	122	Ceramic
R107	10 Ω	-	C110	272	Film
R108	20 Ω	-	C111	333	Film
R109	4.7k Ω	-	C201, C202	1000uF/ 35V	Electrolytic
R110	1.2k Ω	-	C203	330uF/ 16V	Electrolytic
R111	0.5 Ω //0.5 Ω //0.5 Ω	2W	C204	2200uF/ 16V	Electrolytic
R112	1k Ω	-	C205	104	Ceramic
R113	12k Ω	-	C301, C302	332/ 1kV	Ceramic
R201, R202	10k Ω	-	INDUCTOR		
R203	1k Ω	-	LF101	30mH	-
R204	330 Ω	-	L201	-	-
MOSFET			DIODE		
Q101	SSH8N80	Fairchild	D101	1N4004	-
IC			D102	FR157	-
IC101	FAN7554	Fairchild	D103	UF4007	-
IC201	KA431	Fairchild	D201	MBRF10100CT	-
IC301	Opto-Coupler	Fairchild	D202	MBR3045PT	-
-	-	-	BD	PBS406GU	-

Transformer specification

Schematic Diagram (Top view)

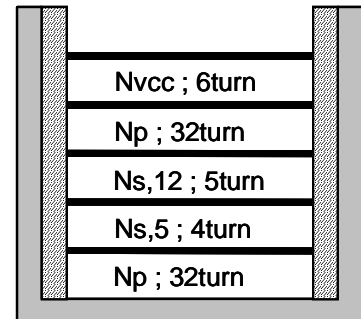
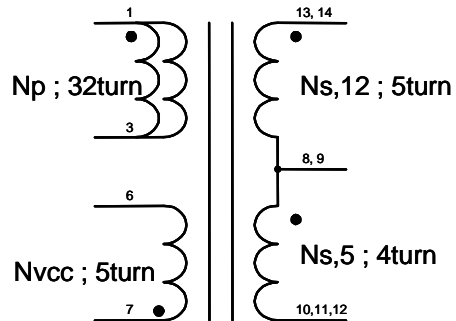

Winding Specification

No.	Pin(S → F)	Wire	Turns
NP	1 → 3	0.65 ϕ × 1	32
NS, 5	8 → 11	0.65 ϕ × 4	4
NS, 12	4 → 9	0.65 ϕ × 4	5
NP	1 → 3	0.65 ϕ × 1	32
NVCC	7 → 6	0.65 ϕ × 1	5

Core : Powder 27 pi 16grade

5V : 12T (1 ϕ × 2)

12V : 27T (1.2 ϕ × 1)

Mechanical Dimensions

Package

Dimensions in millimeters

8-SOP

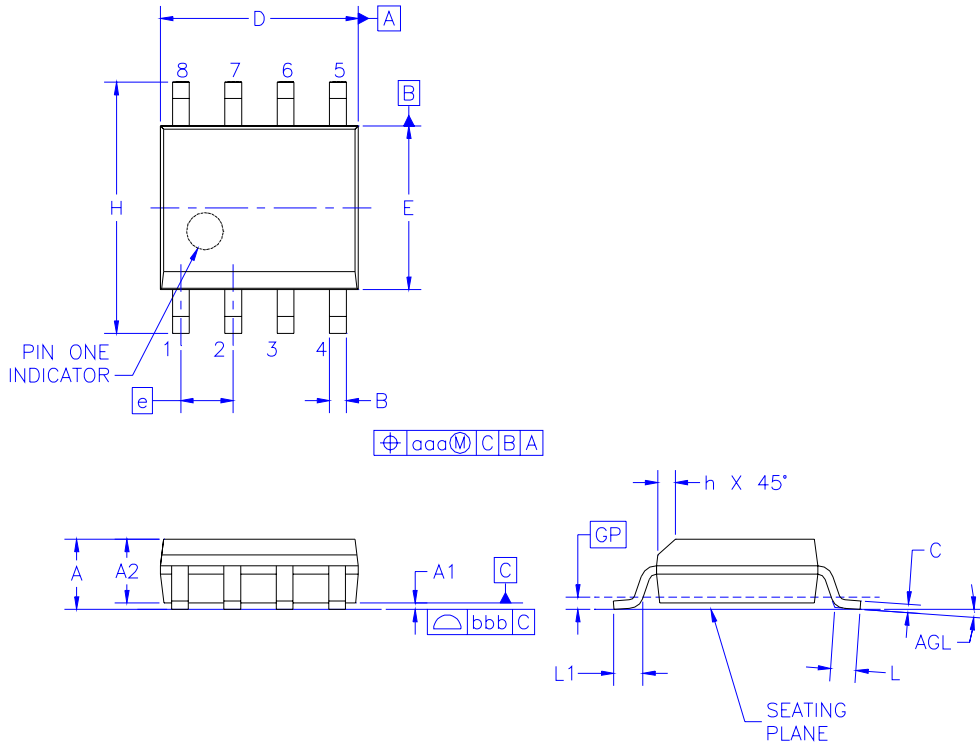

Symbol	Min	Nom	Max
A	-	-	1.75
A1	0.10	0.15	0.25
A2	1.25	1.45	1.50
B	0.35	0.37	0.51
C	0.19	0.20	0.25
D	4.80	4.90	5.00
E	3.80	3.90	4.00
e	1.27BSC		
H	5.79	5.99	6.20
h	0.25	-	0.50
L	0.50	0.70	0.90
GP	0.36 BSC		
q	0	-	8
aaa	-	-	0.25
bbb	-	-	0.10

Mechanical Dimensions (Continued)

Package

Dimensions in millimeters

8-DIP

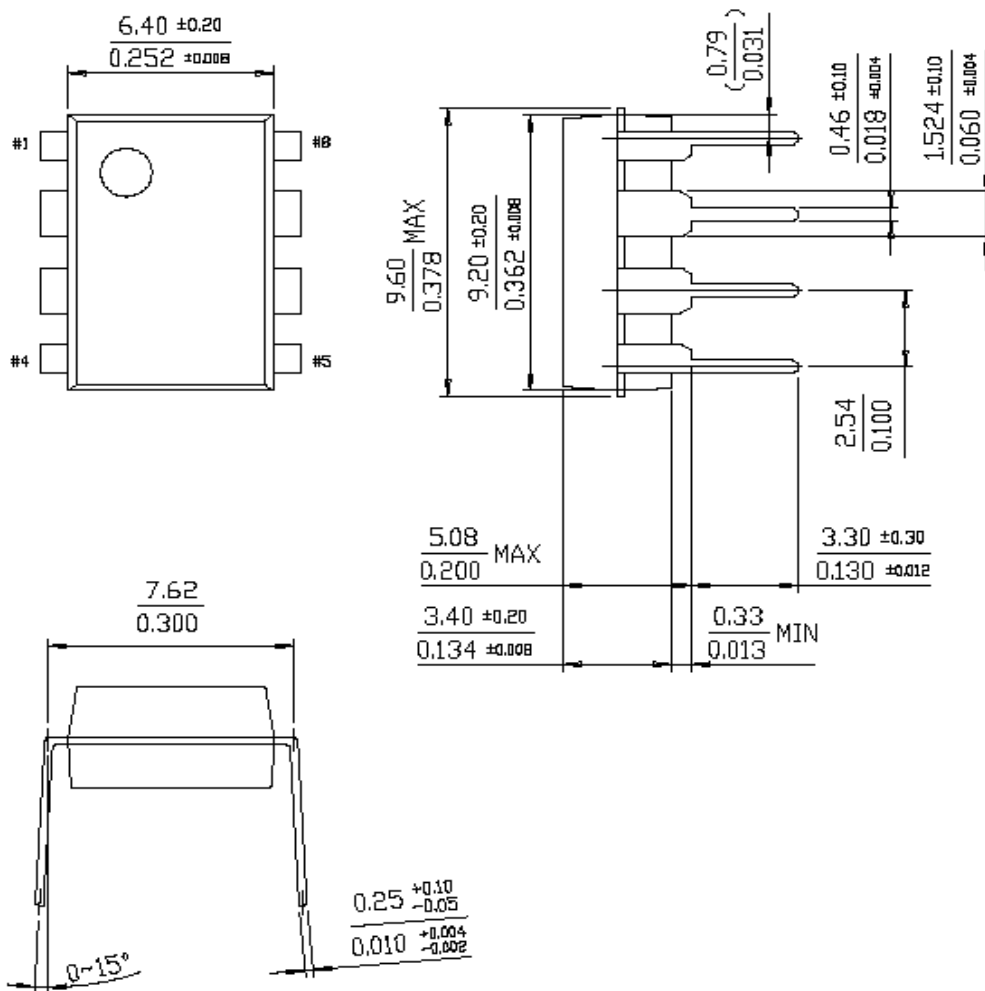

Ordering Information

Product Number	Package	Operating Temperature
FAN7554	8-DIP	-25°C ~ 85°C
FAN7554D	8-SOP	

DISCLAIMER

FAIRCHILD SEMICONDUCTOR RESERVES THE RIGHT TO MAKE CHANGES WITHOUT FURTHER NOTICE TO ANY PRODUCTS HEREIN TO IMPROVE RELIABILITY, FUNCTION OR DESIGN. FAIRCHILD DOES NOT ASSUME ANY LIABILITY ARISING OUT OF THE APPLICATION OR USE OF ANY PRODUCT OR CIRCUIT DESCRIBED HEREIN; NEITHER DOES IT CONVEY ANY LICENSE UNDER ITS PATENT RIGHTS, NOR THE RIGHTS OF OTHERS.

LIFE SUPPORT POLICY

FAIRCHILD'S PRODUCTS ARE NOT AUTHORIZED FOR USE AS CRITICAL COMPONENTS IN LIFE SUPPORT DEVICES OR SYSTEMS WITHOUT THE EXPRESS WRITTEN APPROVAL OF THE PRESIDENT OF FAIRCHILD SEMICONDUCTOR CORPORATION. As used herein:

1. Life support devices or systems are devices or systems which, (a) are intended for surgical implant into the body, or (b) support or sustain life, and (c) whose failure to perform when properly used in accordance with instructions for use provided in the labeling, can be reasonably expected to result in a significant injury of the user.
2. A critical component in any component of a life support device or system whose failure to perform can be reasonably expected to cause the failure of the life support device or system, or to affect its safety or effectiveness.

AMEYA360

Components Supply Platform

Authorized Distribution Brand :



Website :

Welcome to visit www.ameya360.com

Contact Us :

➤ Address :

401 Building No.5, JiuGe Business Center, Lane 2301, Yishan Rd
Minhang District, Shanghai , China

➤ Sales :

Direct +86 (21) 6401-6692

Email amall@ameya360.com

QQ 800077892

Skype [ameyasales1](#) [ameyasales2](#)

➤ Customer Service :

Email service@ameya360.com

➤ Partnership :

Tel +86 (21) 64016692-8333

Email mkt@ameya360.com