

# FSB50250US

## Motion SPM® 5 Series

### Features

- UL Certified No. E209204 (UL1557)
- 500 V  $R_{DS(on)} = 4.2 \Omega$ (Max) FRFET MOSFET 3-Phase Inverter with Gate Drivers and Protection
- Separate Open-Source Pins from Low-Side MOSFETs for Three-Phase Current-Sensing
- Active-HIGH Interface, Works with 3.3 / 5 V Logic, Schmitt-trigger Input
- Optimized for Low Electromagnetic Interference
- HVIC for Gate Driving and Under-Voltage Protection
- Isolation Rating: 1500 V<sub>rms</sub> / min.
- Moisture Sensitive Level (MSL) 3
- RoHS Compliant

### Applications

- 3-Phase Inverter Driver for Small Power AC Motor Drives

### Related Source

- [AN-9082 - Motion SPM5 Series Thermal Performance by Contact Pressure](#)

### General Description

The FSB50250US is an advanced Motion SPM® 5 module providing a fully-featured, high-performance inverter output stage for AC Induction, BLDC and PMSM motors. These modules integrate optimized gate drive of the built-in MOSFETs (FRFET® technology) to minimize EMI and losses, while also providing multiple on-module protection features including under-voltage lockouts. The built-in, high-speed HVIC requires only a single supply voltage and translates the incoming logic-level gate inputs to the high-voltage, high-current drive signals required to properly drive the module's internal MOSFETs. Separate open-source MOSFET terminals are available for each phase to support the widest variety of control algorithms.



### Package Marking & Ordering Information

Device Marking	Device	Package	Reel Size	Packing Type	Quantity
FSB50250US	FSB50250US	SPM5H-023	330mm	Tape-Reel	450

## Absolute Maximum Ratings

**Inverter Part** (each MOSFET unless otherwise specified.)

Symbol	Parameter	Conditions	Rating	Unit
$V_{DSS}$	Drain-Source Voltage of Each MOSFET		500	V
* $I_{D\ 25}$	Each MOSFET Drain Current, Continuous	$T_C = 25^\circ\text{C}$	1.1	A
* $I_{D\ 80}$	Each MOSFET Drain Current, Continuous	$T_C = 80^\circ\text{C}$	0.8	A
* $I_{DP}$	Each MOSFET Drain Current, Peak	$T_C = 25^\circ\text{C}$ , $PW < 100\ \mu\text{s}$	2.8	A
* $P_D$	Maximum Power Dissipation	$T_C = 25^\circ\text{C}$ , For Each MOSFET	13	W

**Control Part** (each HVIC unless otherwise specified.)

Symbol	Parameter	Conditions	Rating	Unit
$V_{CC}$	Control Supply Voltage	Applied Between $V_{CC}$ and COM	20	V
$V_{BS}$	High-side Bias Voltage	Applied Between $V_B$ and $V_S$	20	V
$V_{IN}$	Input Signal Voltage	Applied Between IN and COM	$-0.3 \sim V_{CC} + 0.3$	V

### Thermal Resistance

Symbol	Parameter	Conditions	Rating	Unit
$R_{\theta JC}$	Junction to Case Thermal Resistance	Each MOSFET under Inverter Operating Condition (1st Note 1)	9.3	$^\circ\text{C}/\text{W}$

### Total System

Symbol	Parameter	Conditions	Rating	Unit
$T_J$	Operating Junction Temperature		-40 ~ 150	$^\circ\text{C}$
$T_{STG}$	Storage Temperature		-40 ~ 125	$^\circ\text{C}$
$V_{ISO}$	Isolation Voltage	60 Hz, Sinusoidal, 1 Minute, Connect Pins to Heat Sink Plate	1500	$V_{rms}$

**1st Notes:**

- For the measurement point of case temperature  $T_C$ , please refer to Figure 4.
- Marking "\*" is calculation value or design factor.



**Electrical Characteristics** ( $T_J = 25^\circ\text{C}$ ,  $V_{CC} = V_{BS} = 15\text{ V}$  unless otherwise specified.)

**Inverter Part** (each MOSFET unless otherwise specified.)

Symbol	Parameter	Conditions	Min	Typ	Max	Unit
$BV_{DSS}$	Drain - Source Breakdown Voltage	$V_{IN} = 0\text{ V}$ , $I_D = 1\text{ mA}$ (2nd Note 1)	500	-	-	V
$\Delta BV_{DSS}/\Delta T_J$	Breakdown Voltage Temperature Coefficient	$I_D = 250\mu\text{A}$ , Referenced to $25^\circ\text{C}$	-	0.53	-	V
$I_{DSS}$	Zero Gate Voltage Drain Current	$V_{IN} = 0\text{ V}$ , $V_{DS} = 500\text{ V}$	-	-	250	$\mu\text{A}$
$R_{DS(on)}$	Static Drain - Source Turn-On Resistance	$V_{CC} = V_{BS} = 15\text{ V}$ , $V_{IN} = 5\text{ V}$ , $I_D = 0.5\text{ A}$	-	3.5	4.2	$\Omega$
$V_{SD}$	Drain - Source Diode Forward Voltage	$V_{CC} = V_{BS} = 15\text{ V}$ , $V_{IN} = 0\text{ V}$ , $I_D = -0.5\text{ A}$	-	-	1.2	V
$t_{ON}$	Switching Times	$V_{PN} = 300\text{ V}$ , $V_{CC} = V_{BS} = 15\text{ V}$ , $I_D = 0.5\text{ A}$ $V_{IN} = 0\text{ V} \leftrightarrow 5\text{ V}$ , Inductive Load $L = 3\text{ mH}$ High- and Low-Side MOSFET Switching (2nd Note 2)	-	1050	-	ns
$t_{OFF}$			-	850	-	ns
$t_{rr}$			-	170	-	ns
$E_{ON}$			-	40	-	$\mu\text{J}$
$E_{OFF}$			-	10	-	$\mu\text{J}$
RBSOA	Reverse Bias Safe Operating Area	$V_{PN} = 400\text{ V}$ , $V_{CC} = V_{BS} = 15\text{ V}$ , $I_D = I_{DP}$ , $V_{DS} = BV_{DSS}$ , $T_J = 150^\circ\text{C}$ High- and Low-Side MOSFET Switching (2nd Note 3)	Full Square			

**Control Part** (each HVIC unless otherwise specified.)

Symbol	Parameter	Conditions	Min	Typ	Max	Unit		
$I_{QCC}$	Quiescent $V_{CC}$ Current	$V_{CC} = 15\text{ V}$ , $V_{IN} = 0\text{ V}$	Applied Between $V_{CC}$ and COM		-	-	160	$\mu\text{A}$
$I_{QBS}$	Quiescent $V_{BS}$ Current	$V_{BS} = 15\text{ V}$ , $V_{IN} = 0\text{ V}$	Applied Between $V_{B(U)} - U$ , $V_{B(V)} - V$ , $V_{B(W)} - W$		-	-	100	$\mu\text{A}$
$UV_{CCD}$	Low-Side Under-Voltage Protection (Figure 8)	$V_{CC}$ Under-Voltage Protection Detection Level		7.4	8.0	9.4	V	
$UV_{CCR}$		$V_{CC}$ Under-Voltage Protection Reset Level		8.0	8.9	9.8	V	
$UV_{BSD}$	High-Side Under-Voltage Protection (Figure 9)	$V_{BS}$ Under-Voltage Protection Detection Level		7.4	8.0	9.4	V	
$UV_{BSR}$		$V_{BS}$ Under-Voltage Protection Reset Level		8.0	8.9	9.8	V	
$V_{IH}$	ON Threshold Voltage	Logic HIGH Level	Applied between IN and COM		3.0	-	-	V
$V_{IL}$	OFF Threshold Voltage	Logic LOW Level			-	-	0.8	V
$I_{IH}$	Input Bias Current	$V_{IN} = 5\text{ V}$		-	10	20	$\mu\text{A}$	
$I_{IL}$		$V_{IN} = 0\text{ V}$		-	-	2	$\mu\text{A}$	

**2nd Notes:**

- $BV_{DSS}$  is the absolute maximum voltage rating between drain and source terminal of each MOSFET inside Motion SPM® 5 product.  $V_{PN}$  should be sufficiently less than this value considering the effect of the stray inductance so that  $V_{PN}$  should not exceed  $BV_{DSS}$  in any case.
- $t_{ON}$  and  $t_{OFF}$  include the propagation delay of the internal drive IC. Listed values are measured at the laboratory test condition, and they can be different according to the field applications due to the effect of different printed circuit boards and wirings. Please see Figure 4 for the switching time definition with the switching test circuit of Figure 5.
- The peak current and voltage of each MOSFET during the switching operation should be included in the Safe Operating Area (SOA). Please see Figure 5 for the RBSOA test circuit that is same as the switching test circuit.

## Recommended Operating Condition

Symbol	Parameter	Conditions	Min.	Typ.	Max.	Unit
$V_{PN}$	Supply Voltage	Applied Between P and N	-	300	400	V
$V_{CC}$	Control Supply Voltage	Applied Between $V_{CC}$ and COM	13.5	15.0	16.5	V
$V_{BS}$	High-Side Bias Voltage	Applied Between $V_B$ and $V_S$	13.5	15.0	16.5	V
$V_{IN(ON)}$	Input ON Threshold Voltage	Applied Between IN and COM	3.0	-	$V_{CC}$	V
$V_{IN(OFF)}$	Input OFF Threshold Voltage		0	-	0.6	V
$t_{dead}$	Blanking Time for Preventing Arm-Short	$V_{CC} = V_{BS} = 13.5 \sim 16.5$ V, $T_J \leq 150^\circ\text{C}$	1.0	-	-	$\mu\text{s}$
$f_{PWM}$	PWM Switching Frequency	$T_J \leq 150^\circ\text{C}$	-	15	-	kHz

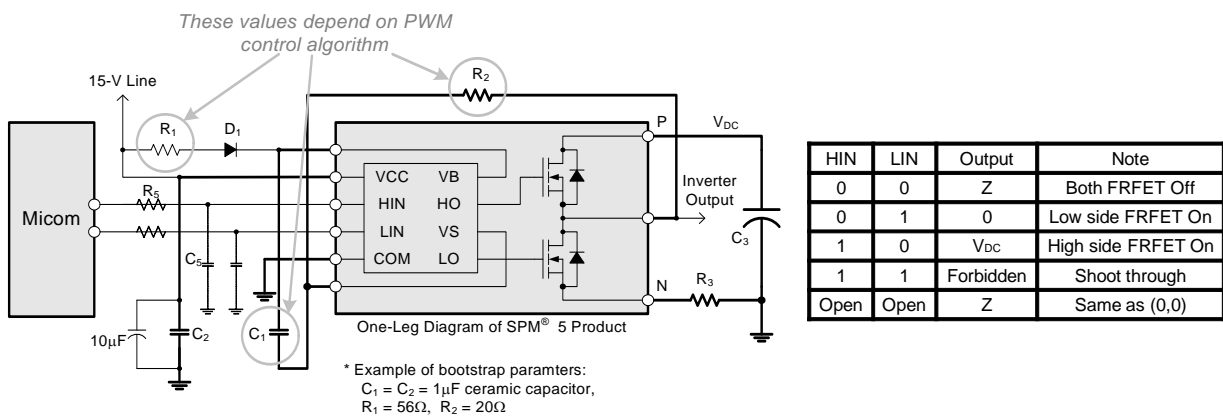

**Figure 2. Recommended MCU Interface and Bootstrap Circuit with Parameters**

### 3rd Notes

1. It is recommended the bootstrap diode  $D_1$  to have soft and fast recovery characteristics with 600 V rating.
2. Parameters for bootstrap circuit elements are dependent on PWM algorithm. For 15 kHz of switching frequency, typical example of parameters is shown above.
3. RC-coupling ( $R_5$  and  $C_5$ ) and  $C_4$  at each input of Motion SPM 5 product and MCU (Indicated as Dotted Lines) may be used to prevent improper signal due to surge-noise.
4. Bold lines should be short and thick in PCB pattern to have small stray inductance of circuit, which results in the reduction of surge-voltage. Bypass capacitors such as  $C_1$ ,  $C_2$  and  $C_3$  should have good high-frequency characteristics to absorb high-frequency ripple-current.

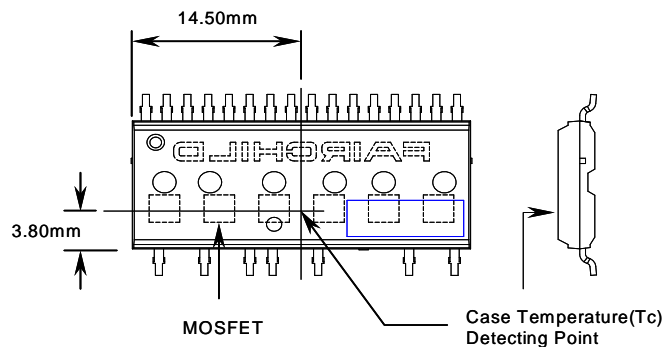

**Figure 3. Case Temperature Measurement**

### 3rd Notes:

5. Attach the thermocouple on top of the heat-sink of SPM 5 package (between SPM 5 package and heatsink if applied) to get the correct temperature measurement.



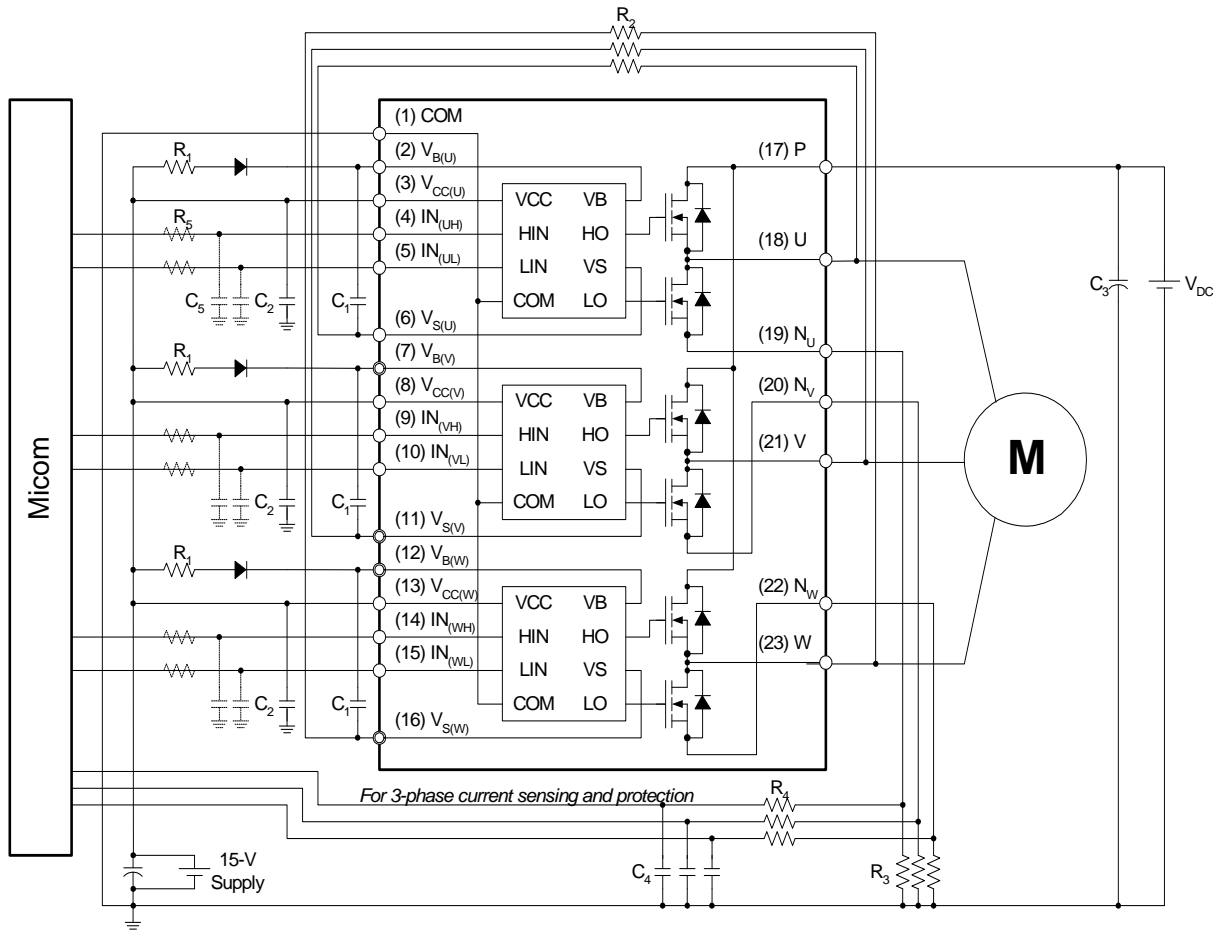
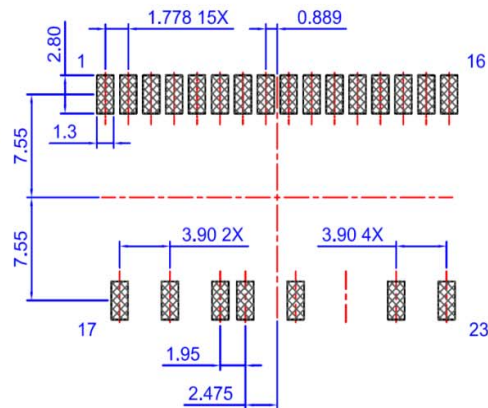
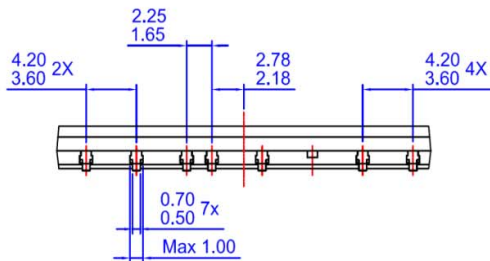
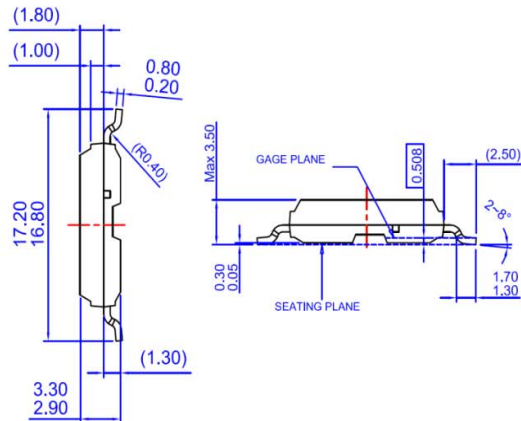
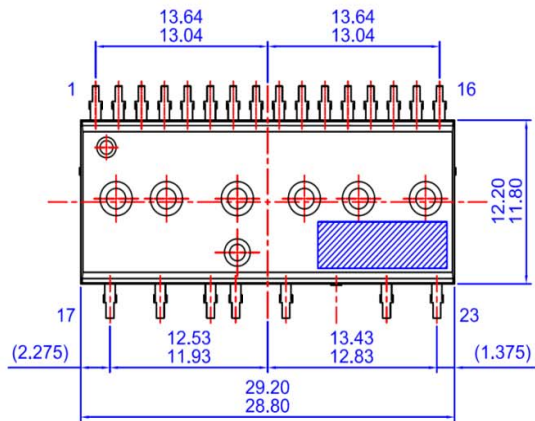
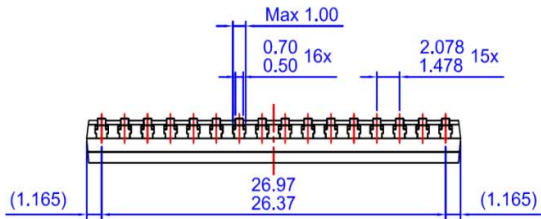

Figure 8. Example of Application Circuit

4th Notes:

1. About pin position, refer to Figure 1.
2. RC-coupling ( $R_5$  and  $C_5$ ,  $R_4$  and  $C_6$ ) and  $C_4$  at each input of Motion SPM® 5 product and MCU are useful to prevent improper input signal caused by surge-noise.
3. The voltage-drop across  $R_3$  affects the low-side switching performance and the bootstrap characteristics since it is placed between COM and the source terminal of the low-side MOSFET. For this reason, the voltage-drop across  $R_3$  should be less than 1 V in the steady-state.
4. Ground-wires and output terminals, should be thick and short in order to avoid surge-voltage and malfunction of HVIC.
5. All the filter capacitors should be connected close to Motion SPM 5 product, and they should have good characteristics for rejecting high-frequency ripple current.

## Detailed Package Outline Drawings



LAND PATTERN RECOMMENDATIONS

- NOTES: UNLESS OTHERWISE SPECIFIED  
 A) THIS PACKAGE DOES NOT COMPLY TO ANY CURRENT PACKAGING STANDARD  
 B) ALL DIMENSIONS ARE IN MILLIMETERS  
 C) DIMENSIONS ARE EXCLUSIVE OF BURRS, MOLD FLASH, AND TIE BAR EXTRUSIONS  
 D) ( ) IS REFERENCE  
 E) [ ] IS ASS'Y QUALITY  
 F) DRAWING FILENAME: MOD23DEREV3.0  
 G) FAIRCHILD SEMICONDUCTOR

Package drawings are provided as a service to customers considering Fairchild components. Drawings may change in any manner without notice. Please note the revision and/or data on the drawing and contact a FairchildSemiconductor representative to verify or obtain the most recent revision. Package specifications do not expand the terms of Fairchild's worldwide terms and conditions, specifically the the warranty therein, which covers Fairchild products.





Always visit Fairchild Semiconductor's online packaging area for the most recent package drawings:

<http://www.fairchildsemi.com/dwg/MO/MOD23DE.pdf>



**TRADEMARKS**

The following includes registered and unregistered trademarks and service marks, owned by Fairchild Semiconductor and/or its global subsidiaries, and is not intended to be an exhaustive list of all such trademarks.

- |   |  |   |   |
|---|--|---|---|
| AccuPower™  | F-PFS™   |                                        | Sync-Lock™  |
| AX-CAP®*  | FRFET®   | PowerTrench®  |  SYSTEM GENERAL® |
| BitSiC™   | Global Power Resource™                         | PowerXS™  | TinyBoost®  |
| Build it Now™   | GreenBridge™                                   | Programmable Active Droop™  | TinyBuck®   |
| CorePLUS™   | Green FPS™                                     | QFET®   | TinyCalc™   |
| CorePOWER™  | Green FPS™ e-Series™                           | QS™   | TinyLogic®  |
| CROSSVOLT™  | Gmax™  | Quiet Series™   | TINYOPTO™   |
| CTL™  | GTO™   | RapidConfigure™   | TinyPower™  |
| Current Transfer Logic™   | IntelliMAX™                                    |  Saving our world, 1mW/W/kW at a time™ | TinyPWM™  |
| DEUXPEED®   | ISOPLANAR™                                     | SignalWise™   | TinyWire™   |
| Dual Cool™  | Making Small Speakers Sound Louder and Better™ | SmartMax™   | TranSiC™  |
| EcoSPARK®   | MegaBuck™                                      | SMART START™  | TriFault Detect™  |
| EfficientMax™   | MICROCOUPLER™                                  | Solutions for Your Success™   | TRUECURRENT®*   |
| ESBC™   | MicroFET™                                      | SPM®  |  SerDes®         |
|  | MicroPak™                                      | STEALTH™  | UHC®  |
| Fairchild®  | MicroPak2™                                     | SuperFET®   | Ultra FRFET™  |
| Fairchild Semiconductor®  | MillerDrive™                                   | SuperSOT™-3   | UniFET™   |
| FACT Quiet Series™  | MotionMax™                                     | SuperSOT™-6   | VCX™  |
| FACT®   | mWSaver®                                       | SuperSOT™-8   | VisualMax™  |
| FAST®   | OptoHiT™                                       | SupreMOS®   | VoltagePlus™  |
| FastvCore™  | OPTOLOGIC®                                     | SyncFET™  | XS™   |
| FETBench™   | OPTOPLANAR®                                    |   |   |
| FPS™  |  |   |   |

\* Trademarks of System General Corporation, used under license by Fairchild Semiconductor.

**DISCLAIMER**

FAIRCHILD SEMICONDUCTOR RESERVES THE RIGHT TO MAKE CHANGES WITHOUT FURTHER NOTICE TO ANY PRODUCTS HEREIN TO IMPROVE RELIABILITY, FUNCTION, OR DESIGN. FAIRCHILD DOES NOT ASSUME ANY LIABILITY ARISING OUT OF THE APPLICATION OR USE OF ANY PRODUCT OR CIRCUIT DESCRIBED HEREIN; NEITHER DOES IT CONVEY ANY LICENSE UNDER ITS PATENT RIGHTS, NOR THE RIGHTS OF OTHERS. THESE SPECIFICATIONS DO NOT EXPAND THE TERMS OF FAIRCHILD'S WORLDWIDE TERMS AND CONDITIONS, SPECIFICALLY THE WARRANTY THEREIN, WHICH COVERS THESE PRODUCTS.

**LIFE SUPPORT POLICY**

FAIRCHILD'S PRODUCTS ARE NOT AUTHORIZED FOR USE AS CRITICAL COMPONENTS IN LIFE SUPPORT DEVICES OR SYSTEMS WITHOUT THE EXPRESS WRITTEN APPROVAL OF FAIRCHILD SEMICONDUCTOR CORPORATION.

As used herein:

1. Life support devices or systems are devices or systems which, (a) are intended for surgical implant into the body or (b) support or sustain life, and (c) whose failure to perform when properly used in accordance with instructions for use provided in the labeling, can be reasonably expected to result in a significant injury of the user.
2. A critical component in any component of a life support, device, or system whose failure to perform can be reasonably expected to cause the failure of the life support device or system, or to affect its safety or effectiveness.

**ANTI-COUNTERFEITING POLICY**

Fairchild Semiconductor Corporation's Anti-Counterfeiting Policy. Fairchild's Anti-Counterfeiting Policy is also stated on our external website, [www.fairchildsemi.com](http://www.fairchildsemi.com), under Sales Support.

Counterfeiting of semiconductor parts is a growing problem in the industry. All manufacturers of semiconductor products are experiencing counterfeiting of their parts. Customers who inadvertently purchase counterfeit parts experience many problems such as loss of brand reputation, substandard performance, failed applications, and increased cost of production and manufacturing delays. Fairchild is taking strong measures to protect ourselves and our customers from the proliferation of counterfeit parts. Fairchild strongly encourages customers to purchase Fairchild parts either directly from Fairchild or from Authorized Fairchild Distributors who are listed by country on our web page cited above. Products customers buy either from Fairchild directly or from Authorized Fairchild Distributors are genuine parts, have full traceability, meet Fairchild's quality standards for handling and storage and provide access to Fairchild's full range of up-to-date technical and product information. Fairchild and our Authorized Distributors will stand behind all warranties and will appropriately address any warranty issues that may arise. Fairchild will not provide any warranty coverage or other assistance for parts bought from Unauthorized Sources. Fairchild is committed to combat this global problem and encourage our customers to do their part in stopping this practice by buying direct or from authorized distributors.

**PRODUCT STATUS DEFINITIONS**

**Definition of Terms**

Datasheet Identification	Product Status	Definition
Advance Information	Formative / In Design	Datasheet contains the design specifications for product development. Specifications may change in any manner without notice.
Preliminary	First Production	Datasheet contains preliminary data; supplementary data will be published at a later date. Fairchild Semiconductor reserves the right to make changes at any time without notice to improve design.
No Identification Needed	Full Production	Datasheet contains final specifications. Fairchild Semiconductor reserves the right to make changes at any time without notice to improve the design.
Obsolete	Not In Production	Datasheet contains specifications on a product that is discontinued by Fairchild Semiconductor. The datasheet is for reference information only.

Rev. 166

# AMEYA360

## Components Supply Platform

### Authorized Distribution Brand :



### Website :

Welcome to visit [www.ameya360.com](http://www.ameya360.com)

### Contact Us :

#### ➤ Address :

401 Building No.5, JiuGe Business Center, Lane 2301, Yishan Rd  
Minhang District, Shanghai , China

#### ➤ Sales :

Direct +86 (21) 6401-6692

Email [amall@ameya360.com](mailto:amall@ameya360.com)

QQ 800077892

Skype [ameyasales1](#) [ameyasales2](#)

#### ➤ Customer Service :

Email [service@ameya360.com](mailto:service@ameya360.com)

#### ➤ Partnership :

Tel +86 (21) 64016692-8333

Email [mkt@ameya360.com](mailto:mkt@ameya360.com)