

CCM03 Series

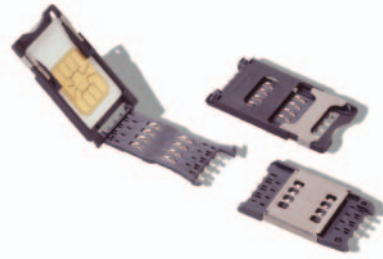

Features

- SIM/SAM card acceptance
- Hinged and fixed covers
- Compatible with pick and place and lead free soldering

Typical Applications

- Handheld products
- Identification
- POS
- Automotive

Mechanical

Number of Contacts	6 or 8
Mechanical life, hinged cover	10,000 cycles min
Mechanical life, fixed cover	50,000 cycles
Card insertion force	Hinged cover: 1N max Fixed cover: 3N max
Card extraction force	Hinged cover: 1N max Fixed cover: 0,80N min / 3N max
Contact force	0,25N min / 0,50N max
Slide locking force	2N min / 6N max 1,8N max. for complete depression
Vibration Frequency	10 to 500 Hz. Acceleration 50m/s ² Duration 6 hours - amplitude 0,35 mm
Max electrical discontinuity	1µs
Shock	Peak value 500 m/s ² – Duration 11 ms 3 shocks in each direction of each axis

Switch Electrical Data

Card detection switch	Normally open
Contact resistance	100 mΩ max
Dielectric strength	250 Vrms min
Current rating	1 mA min / 10m A max
Maximum power	0.2 VA

Environment Data

Operating temperature	-40°C to +85°C
Damp heat	IEC 512 test number 11c (10 days)
Salt mist	IEC 512 test number 11f (96 hours)
RoHS compliant	

Soldering Process

Compatible with lead free SMT soldering process



Contact Electrical Data

Insulation resistance	1,000 MΩ min
Resistance	100 mΩ max
Current rating	10 µA min / 1 A max
Dielectric strength	750 Vrms min

Designation	Contact Plating	Cover	# of Contacts	PCB Version	Card Presence Switch	Operating Life	Total Height (mm)	Dim. (mm)	Packaging
CCM03-3001LFT	inlay	hinged	6		without	10,000	2,55	17,2 x 29,65	reels of 1,000 pcs
CCM03-3002LFT	inlay	hinged	6	2 plastic pegs	without	10,000	2,55	17,2 x 29,65	reels of 1,000 pcs
CCM03-3003LFT	inlay	hinged	8		without	10,000	2,55	17,2 x 29,65	reels of 1,000 pcs
CCM03-3004LFT	inlay	hinged	8	2 plastic pegs	without	10,000	2,55	17,2 x 29,65	reels of 1,000 pcs
CCM03-3009LFT	gold	hinged	6		without	10,000	2,55	17,2 x 29,65	reels of 1,000 pcs
CCM03-3010LFT	gold	hinged	6	2 plastic pegs	without	10,000	2,55	17,2 x 29,65	reels of 1,000 pcs
CCM03-3011LFT	gold	hinged	8		without	10,000	2,55	17,2 x 29,65	reels of 1,000 pcs
CCM03-3012LFT	gold	hinged	8	2 plastic pegs	without	10,000	2,55	17,2 x 29,65	reels of 1,000 pcs
CCM03-3013LFT	gold	hinged	6		with	10,000	2,55	17,2 x 29,65	reels of 1,000 pcs
CCM03-3512LFT	gold	hinged	6	Large soldering pads*	without	10,000	2,55	17,2 x 29,65	reels of 1,000 pcs
CCM03-3519LFT	gold	hinged	6	White cover	without	10,000	2,55	17,2 x 29,65	reels of 1,000 pcs
CCM03-3504LFT	gold	fixed	8		without	50,000	2,85	17,2 x 25,5	reels of 1,000 pcs
CCM03-3505LFT	gold	fixed	6		without	50,000	2,85	17,2 x 25,5	reels of 1,000 pcs
CCM03-3535LFT	inlay	fixed	6		without	50,000	2,85	17,2 x 25,5	reels of 1,000 pcs
CCM03-3754LFT	inlay	fixed	6		with	10,000	3,5	16,5 x 18,05	reels of 1,000 pcs
CCM03-3760LFT	inlay	fixed	6		without	10,000	3,45	16,5 x 15,85	reels of 1,000 pcs
CCM03-3764LFT	inlay	none	6		with	10,000	2,9	16,5 x 15,85	reels of 1,000 pcs

* Can go through reflow upside down

CCM03-3001 LFT / CCM03-3009 LFT

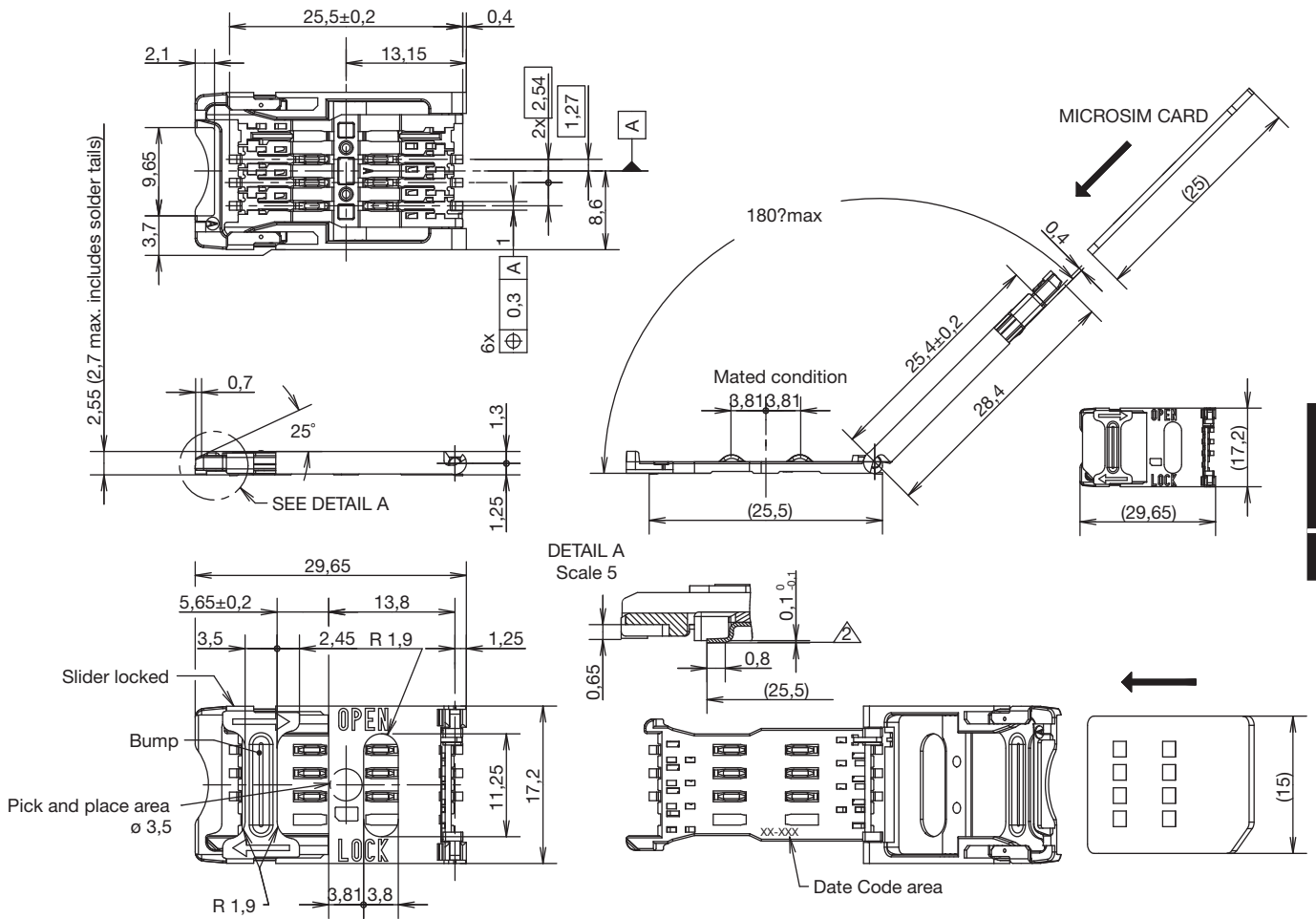

RECOMMENDED PC BOARD LAYOUT
(Component side)

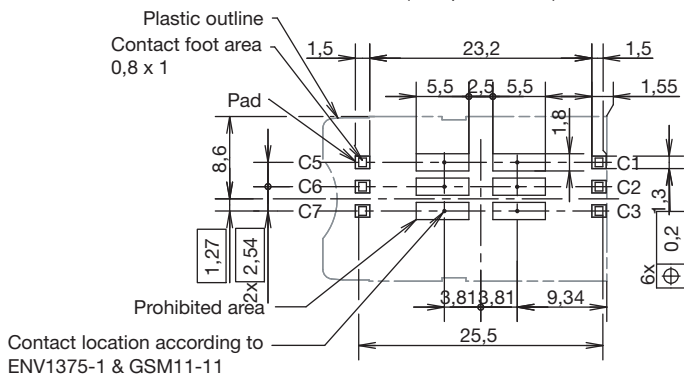

CCM03 Series

CCM03-3002 LFT / CCM03-3010 LFT

SIM/SAM

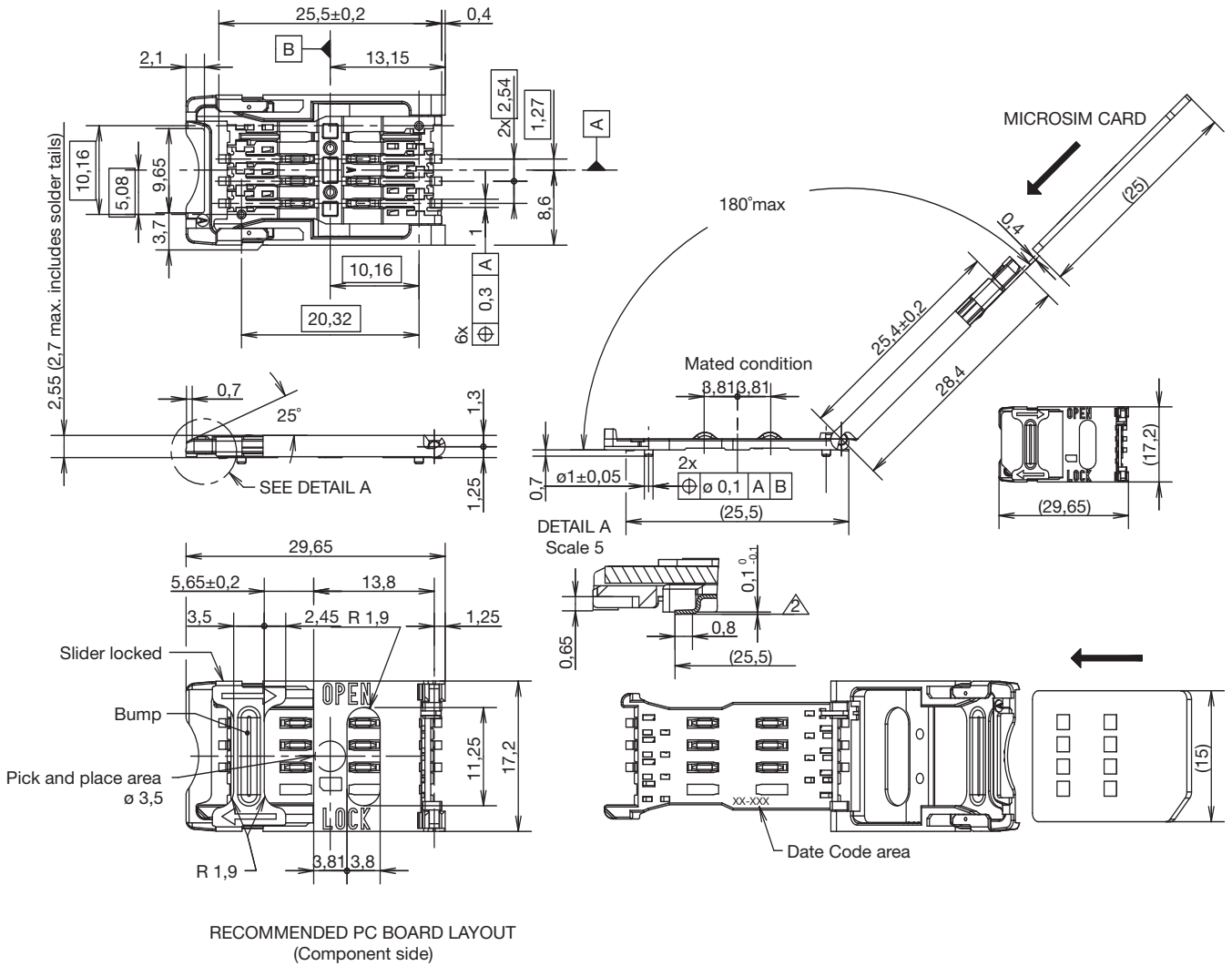

RECOMMENDED PC BOARD LAYOUT
(Component side)

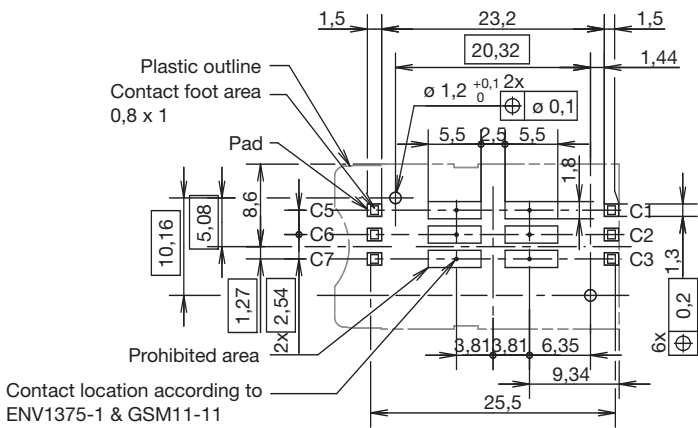

Dimensions are shown in mm
Specifications and dimensions subject to change

www.ck-components.com



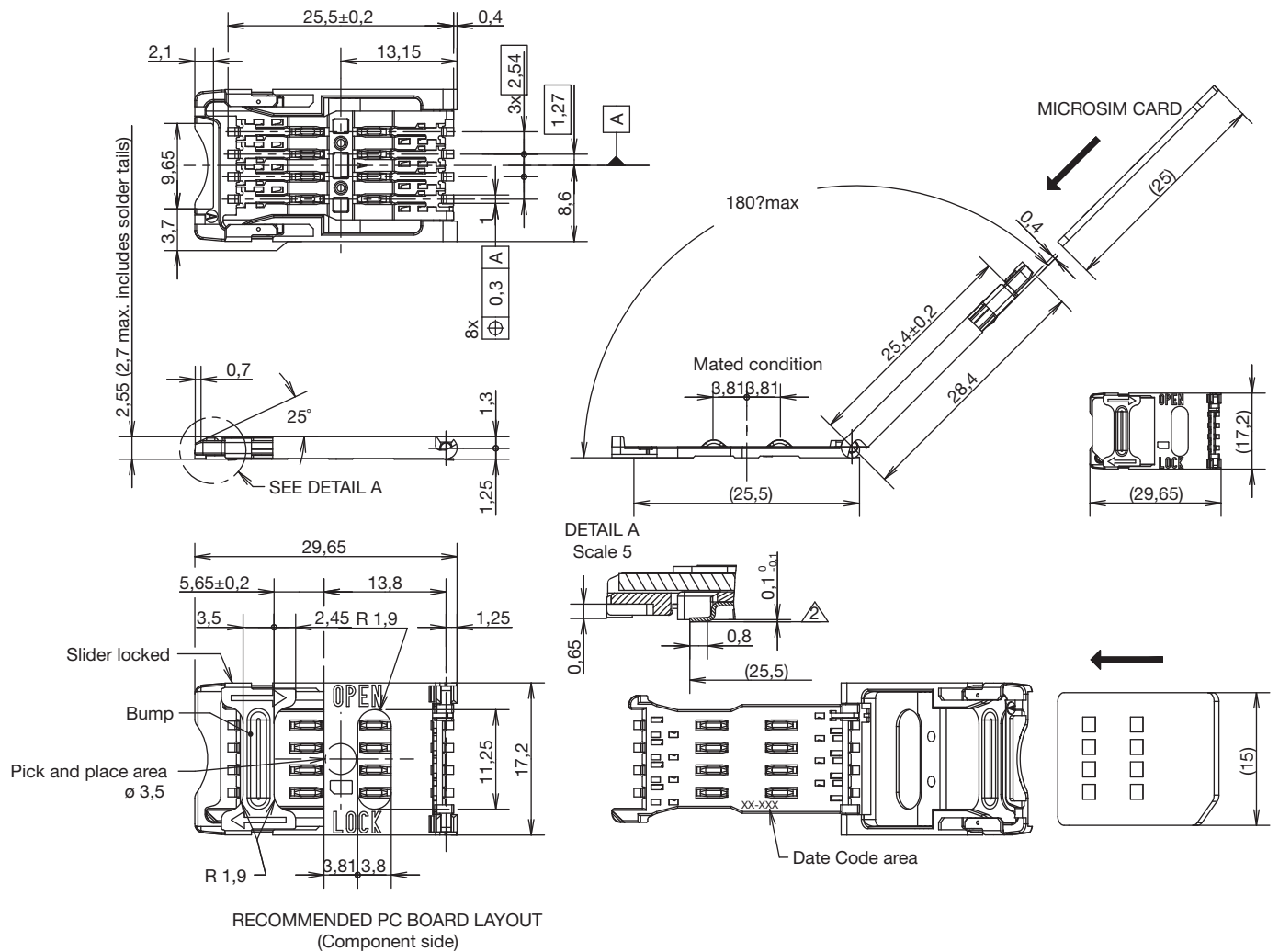

SIM/SAM

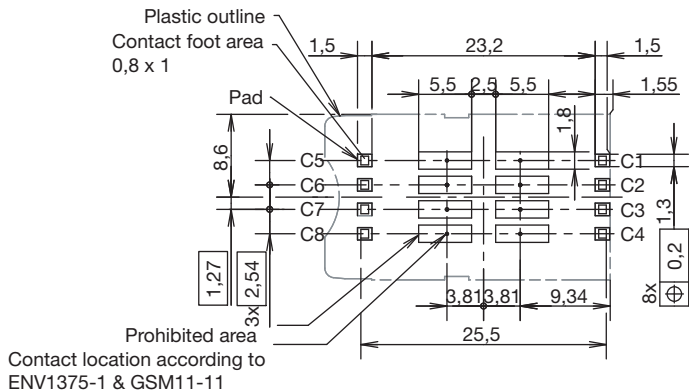

CCM03 Series

CCM03-3004 LFT

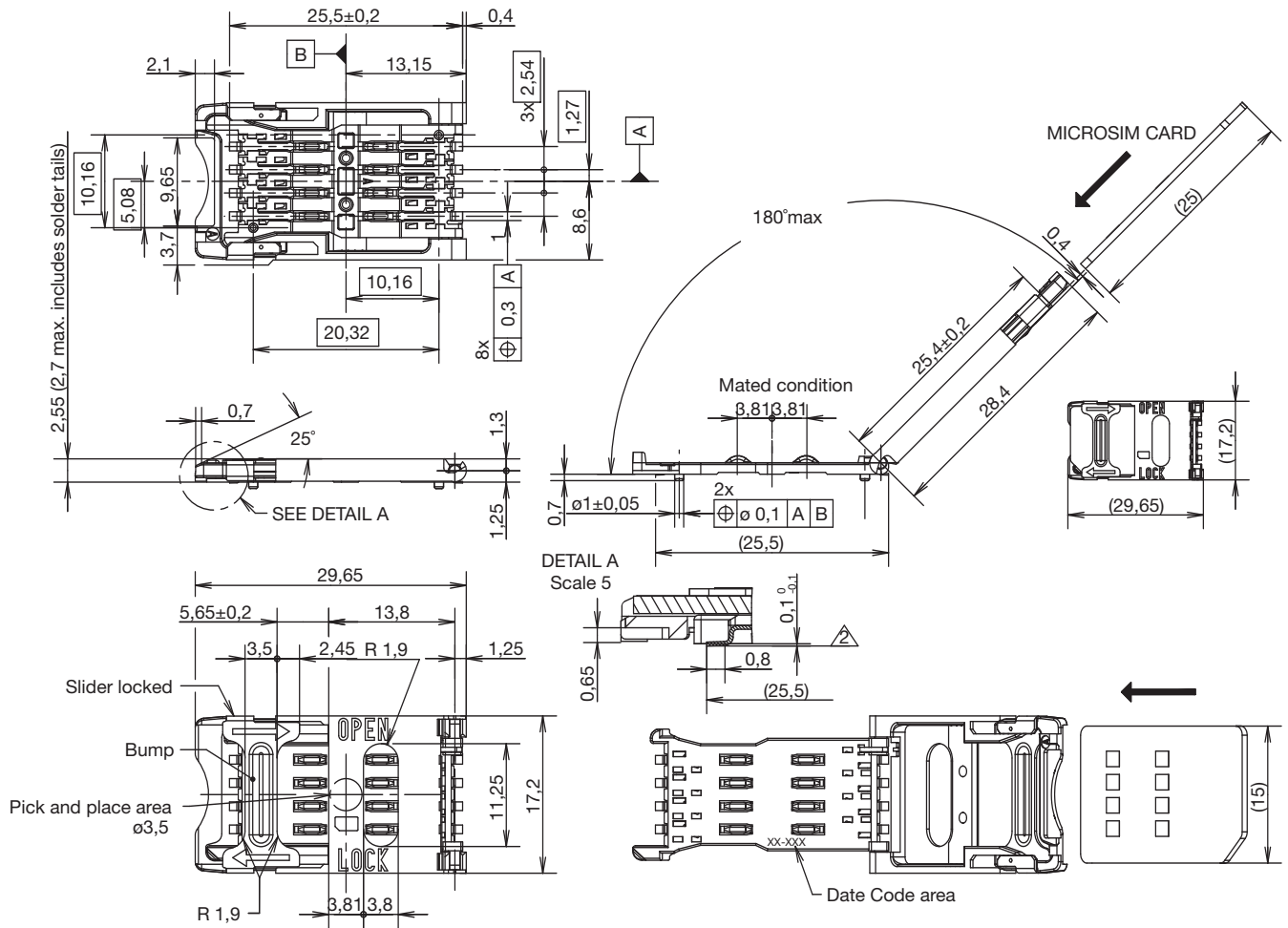

SIM/SAM

RECOMMENDED PC BOARD LAYOUT
(Component side)

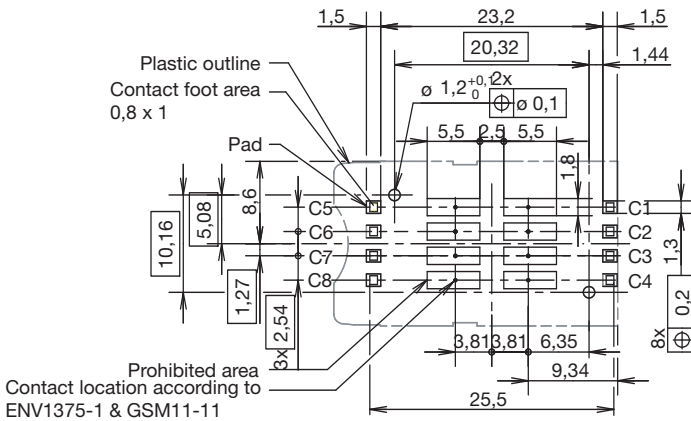

First Angle Projection



Dimensions are shown in mm
Specifications and dimensions subject to change

www.ck-components.com

CCM03-3011 LFT

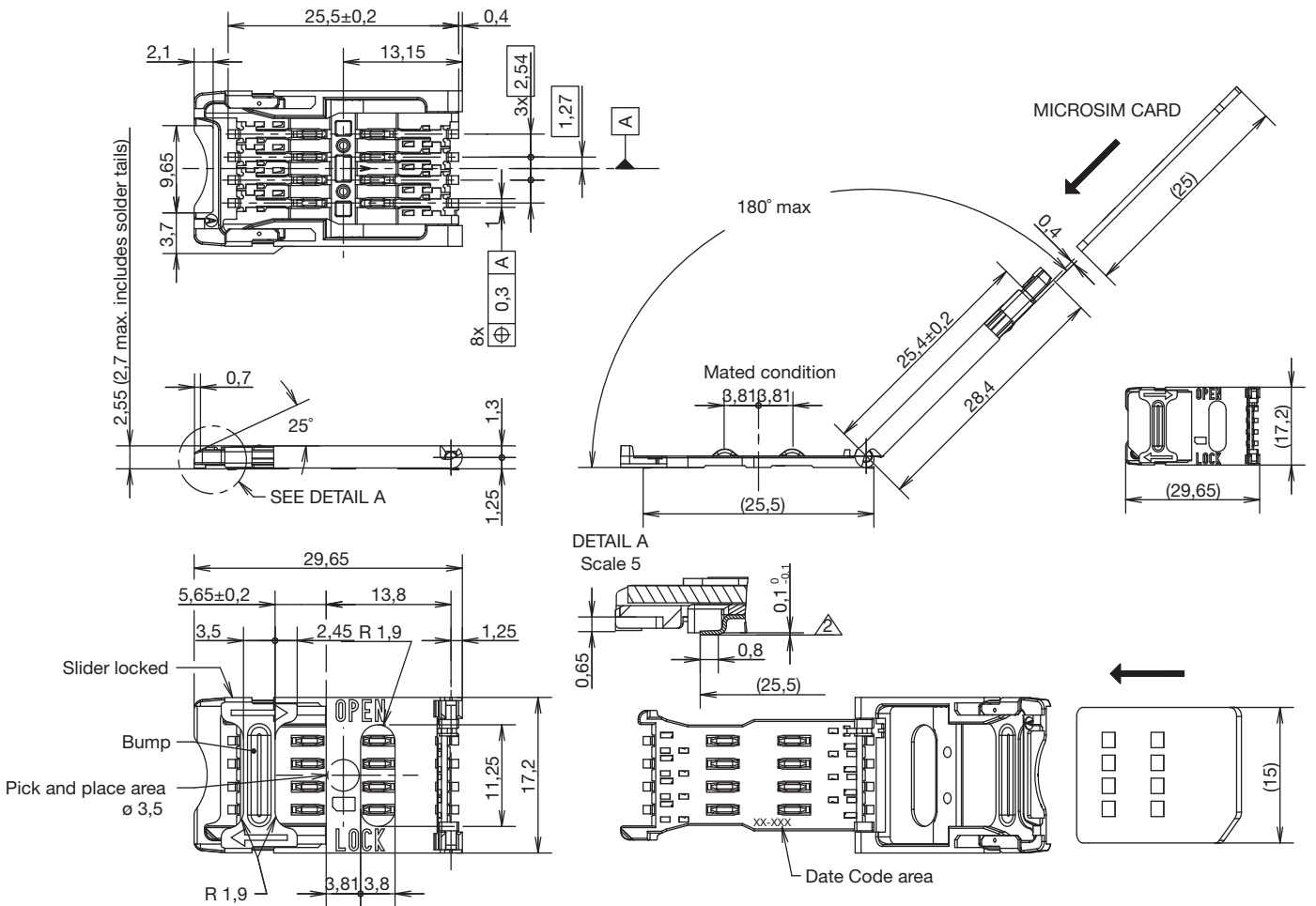

RECOMMENDED PC BOARD LAYOUT (Component side)

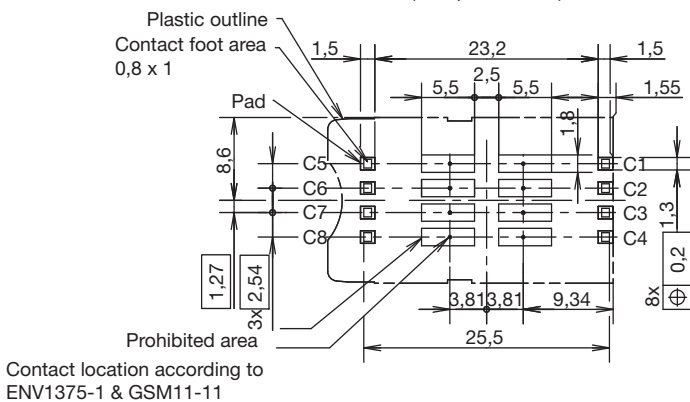

CCM03 Series

CCM03-3012 LFT

SIM/SAM

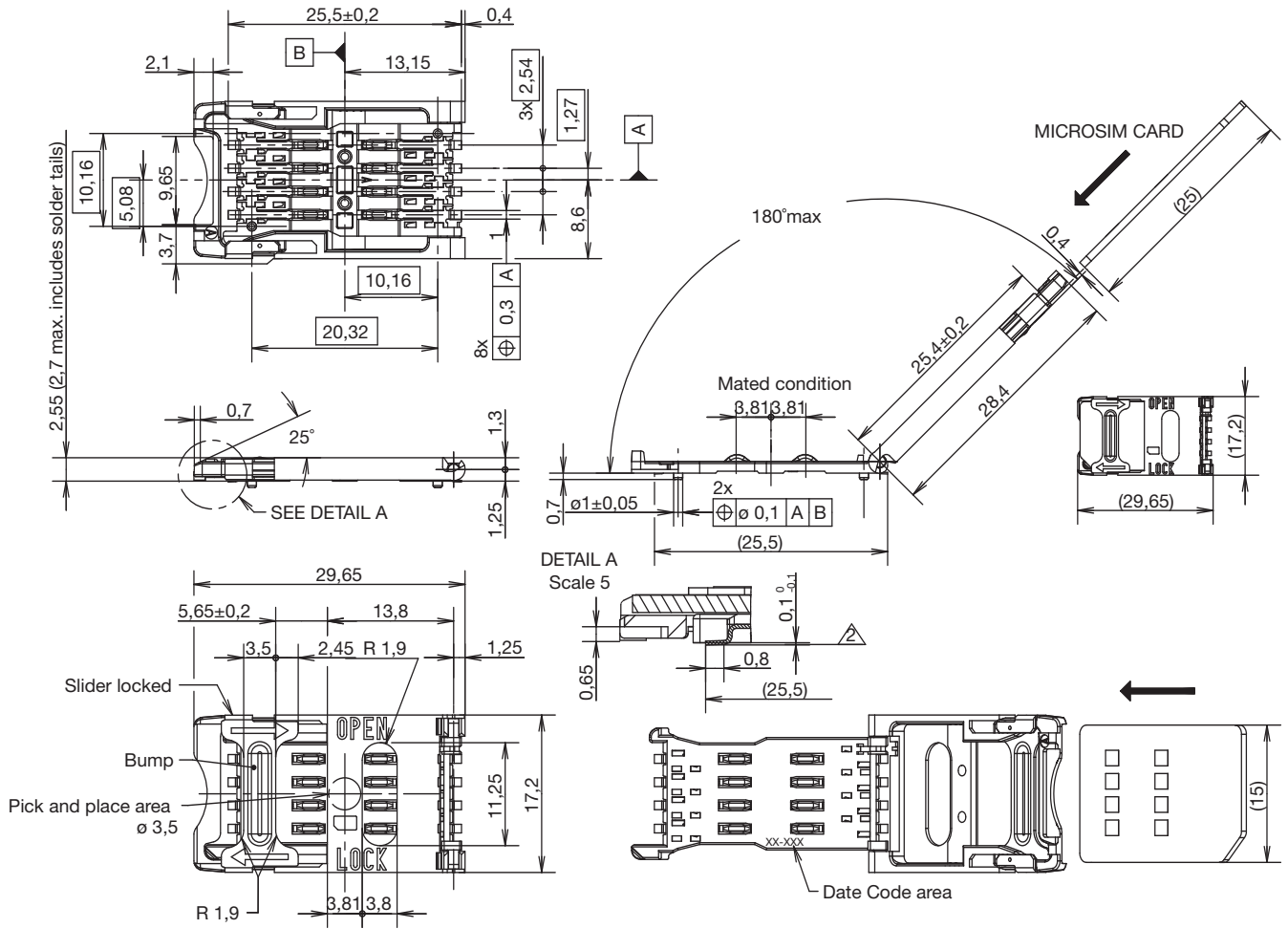

RECOMMENDED PC BOARD LAYOUT
(Component side)

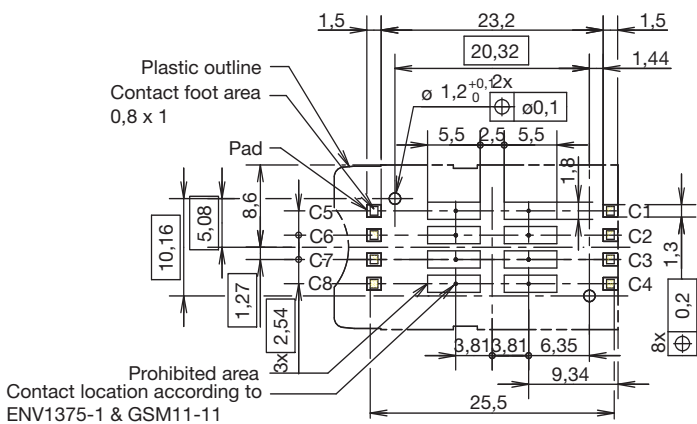

Dimensions are shown in mm
Specifications and dimensions subject to change



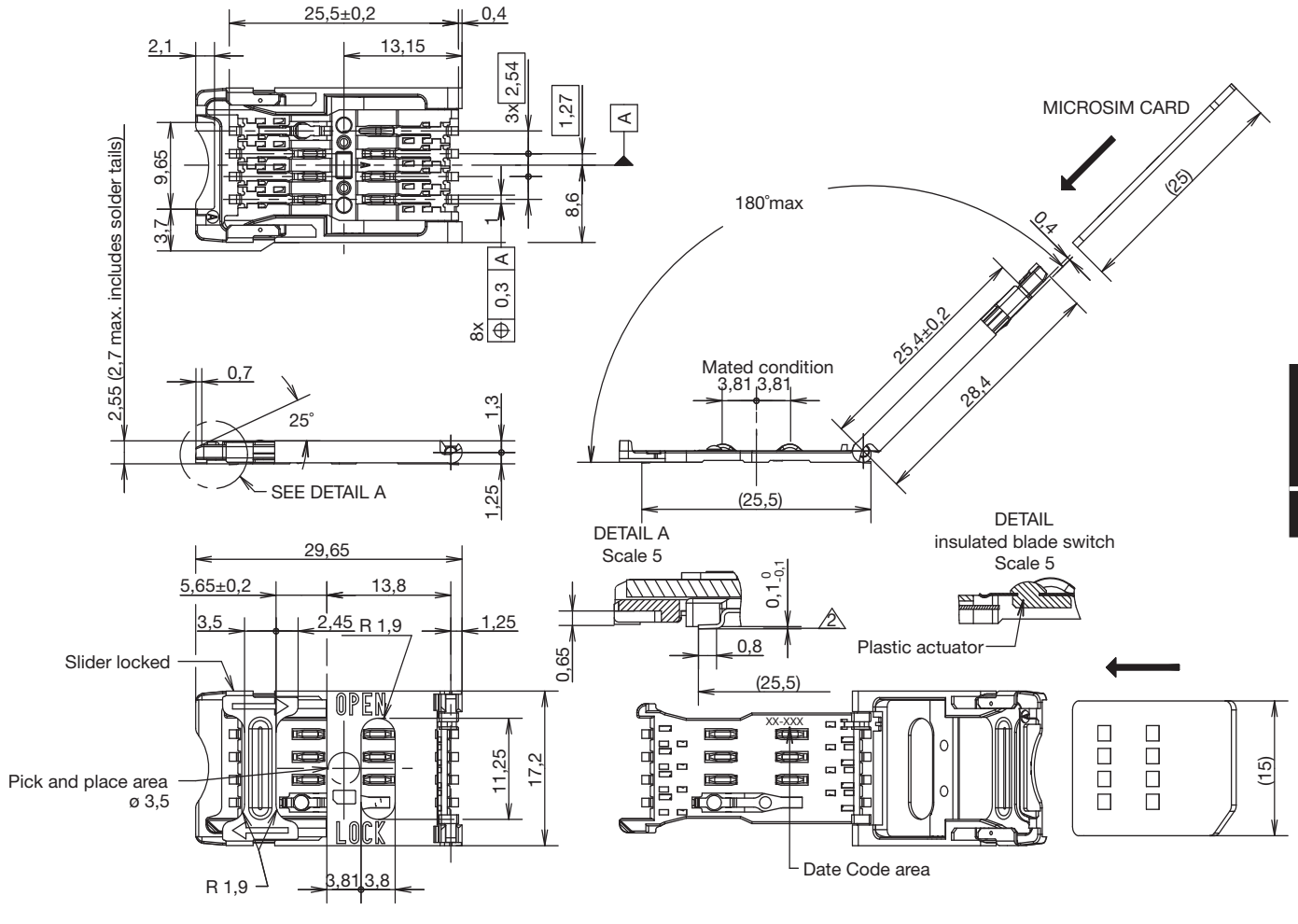

RECOMMENDED PC BOARD LAYOUT
(Component side)

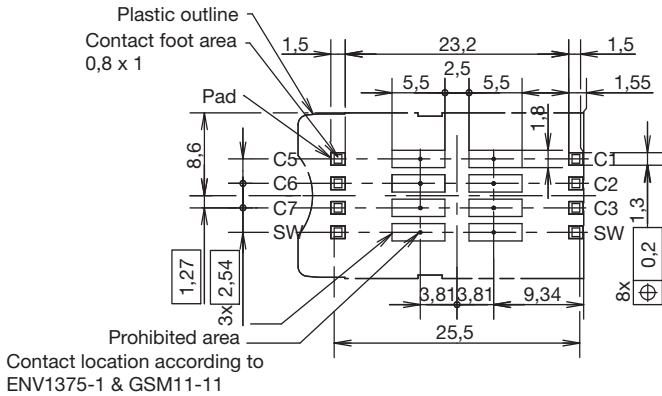

CCM03 Series

CCM03-3512 LFT

SIM/SAM

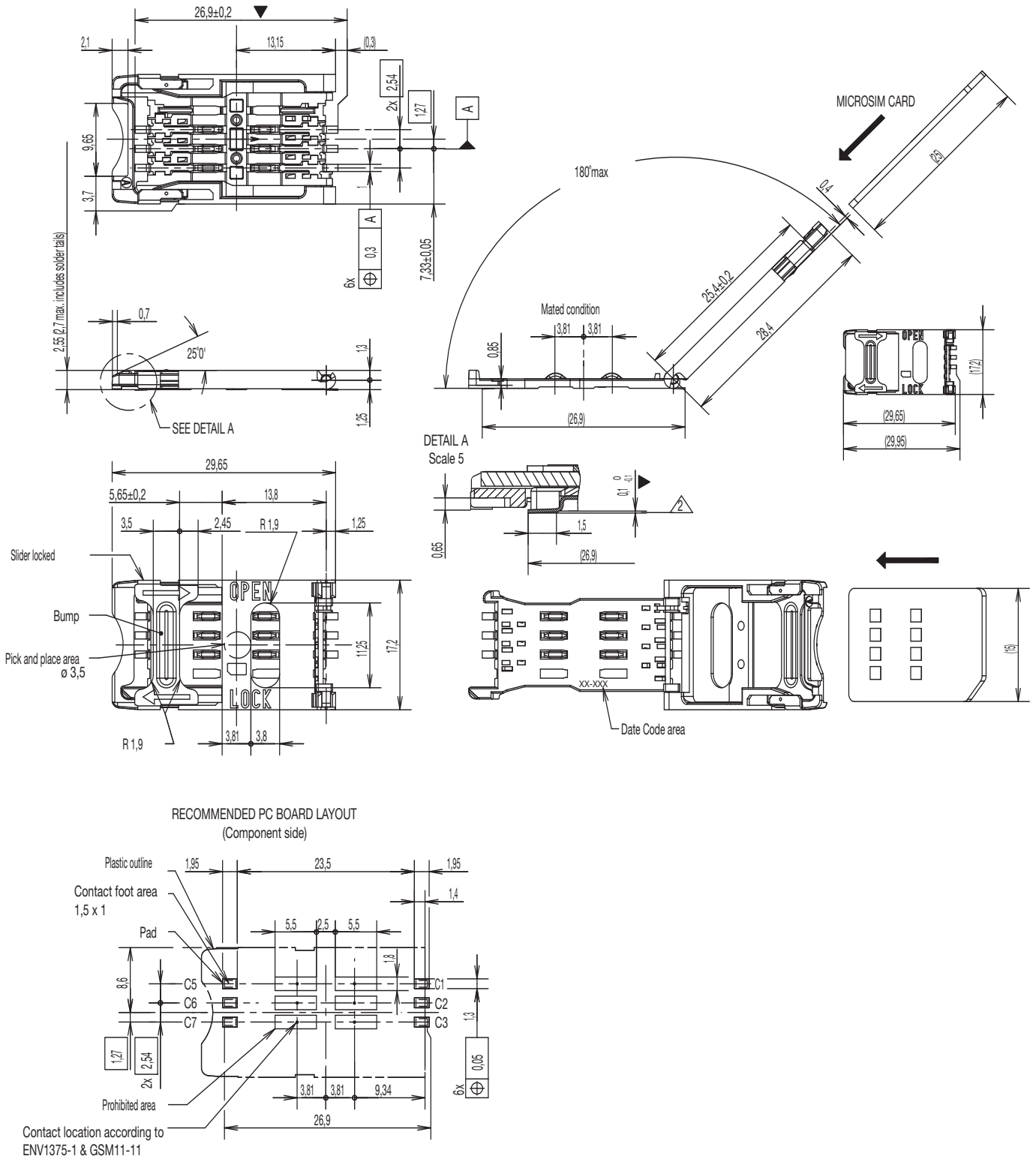

Dimensions are given in mm
Specifications and dimensions subject to change

www.ck-components.com



CCM03-3519 LFT

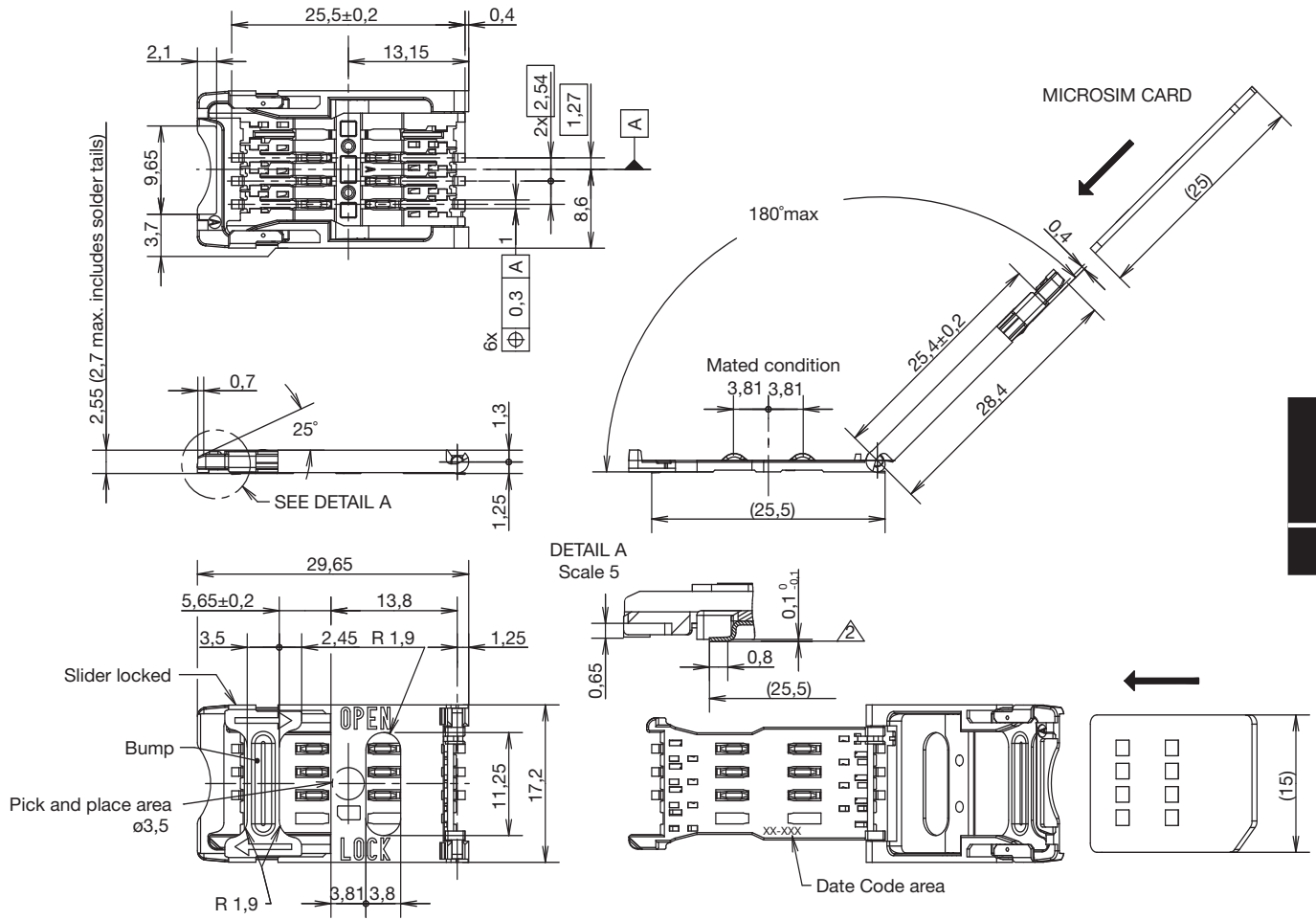

RECOMMENDED PC BOARD LAYOUT
(Component side)

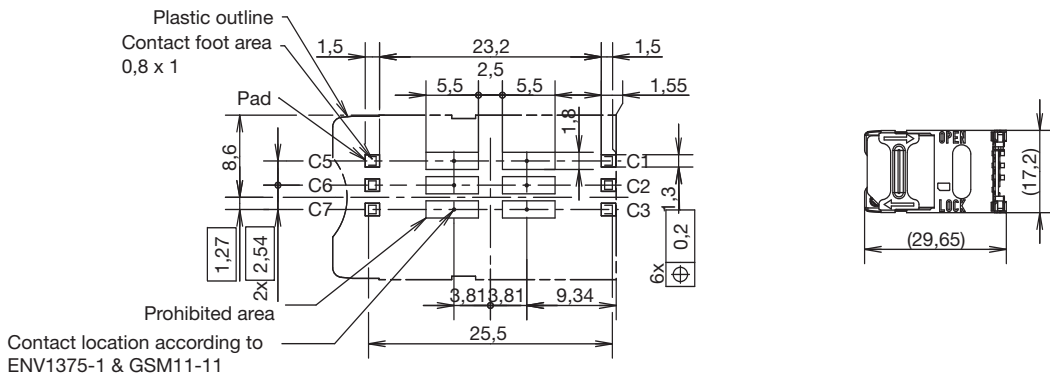

Dimensions are shown in mm
Specifications and dimensions subject to change

www.ck-components.com

CCM03 Series

CCM03-3504 LFT / CCM03-3505 LFT

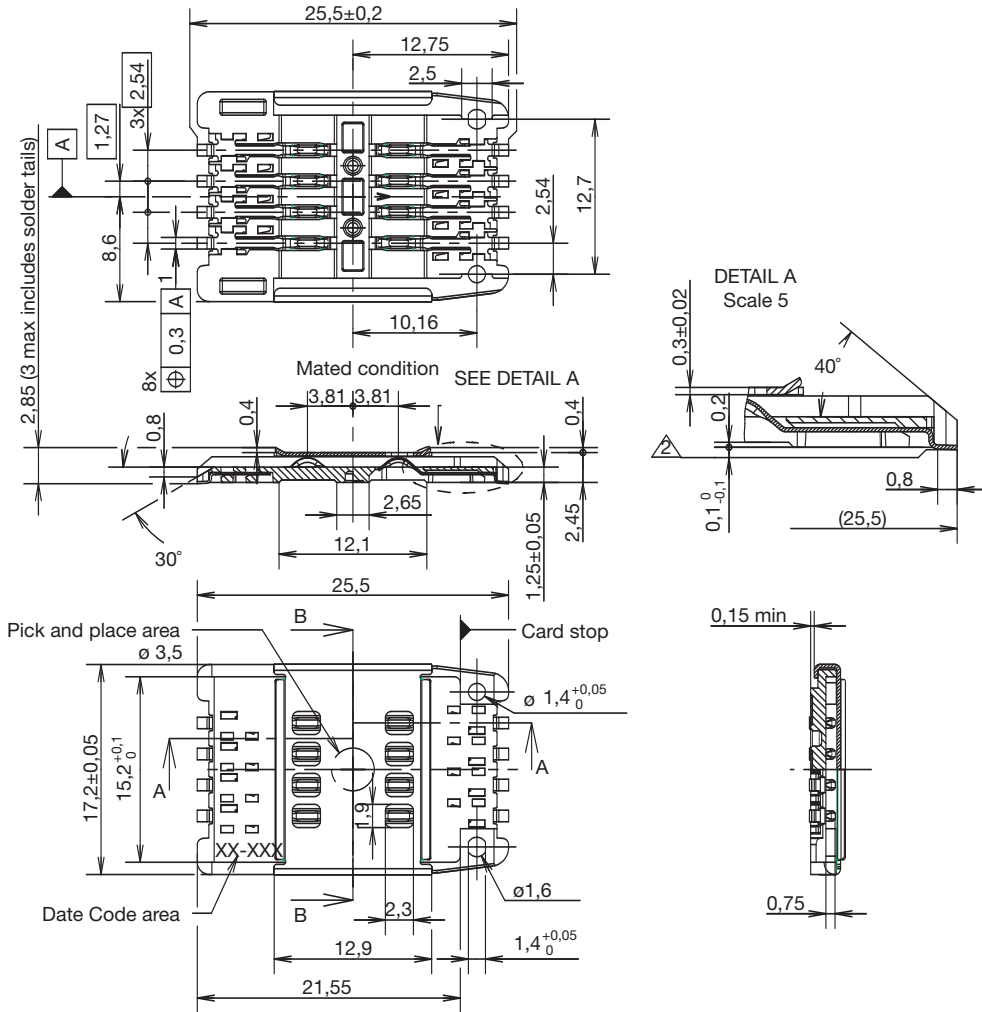

RECOMMENDED PC BOARD LAYOUT
(Component side)

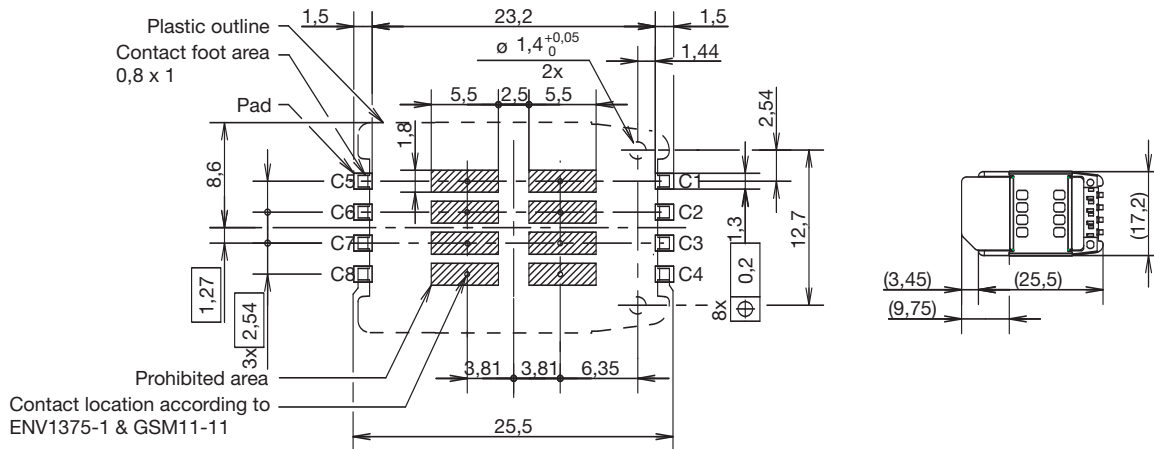

Dimensions are shown in mm
Specifications and dimensions subject to change

SIM/SAM



CCM03-3535 LFT

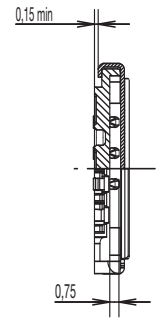
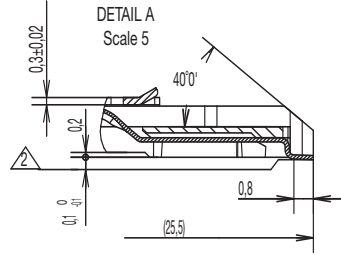
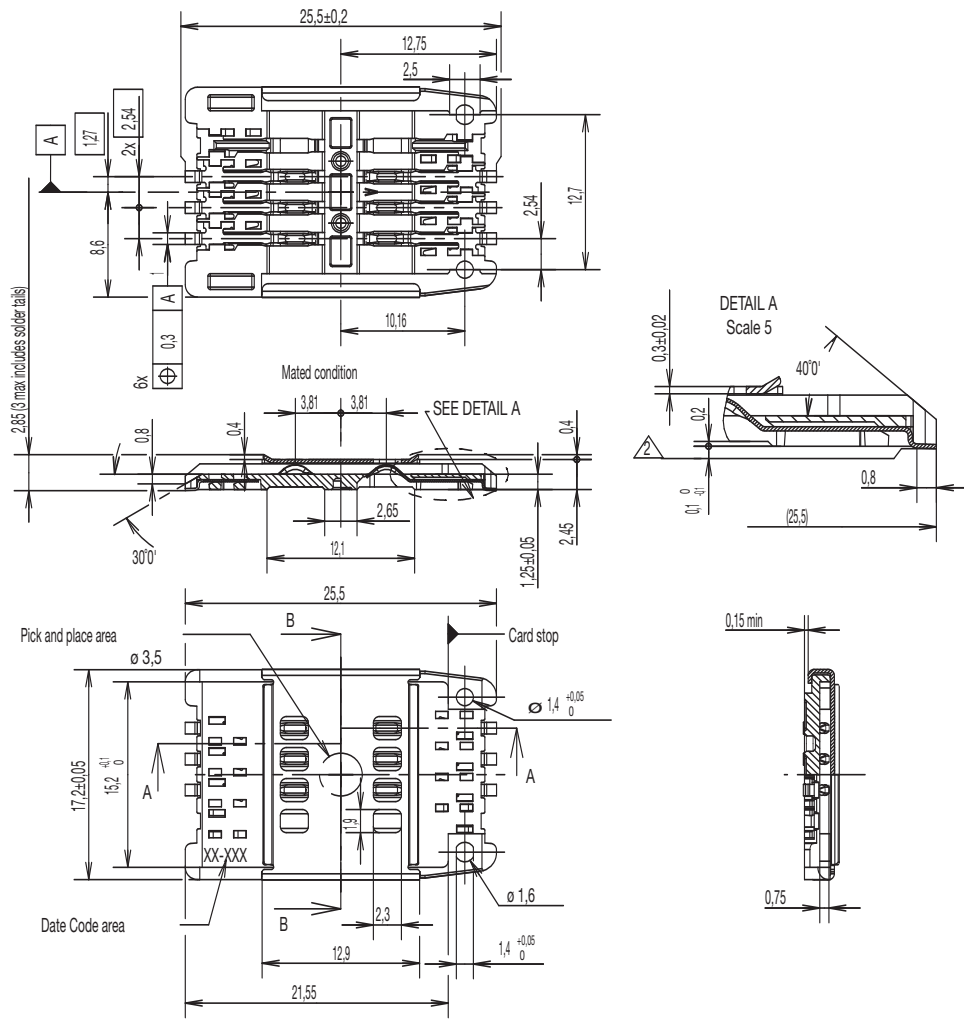

RECOMMENDED PC BOARD LAYOUT
(Component side)

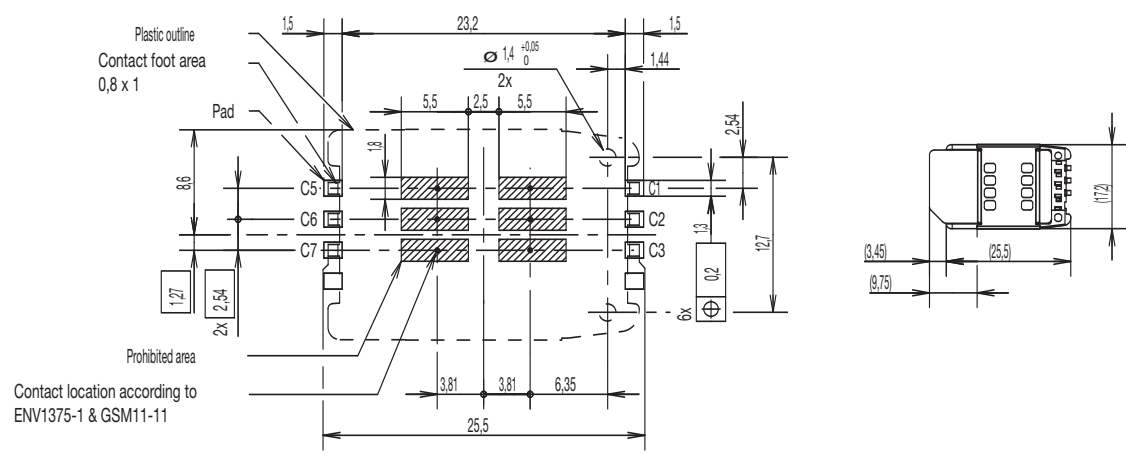

SIM/SAM



Dimensions are shown in mm
Specifications and dimensions subject to change

www.ck-components.com

CCM03 Series

CCM03-3754 LFT

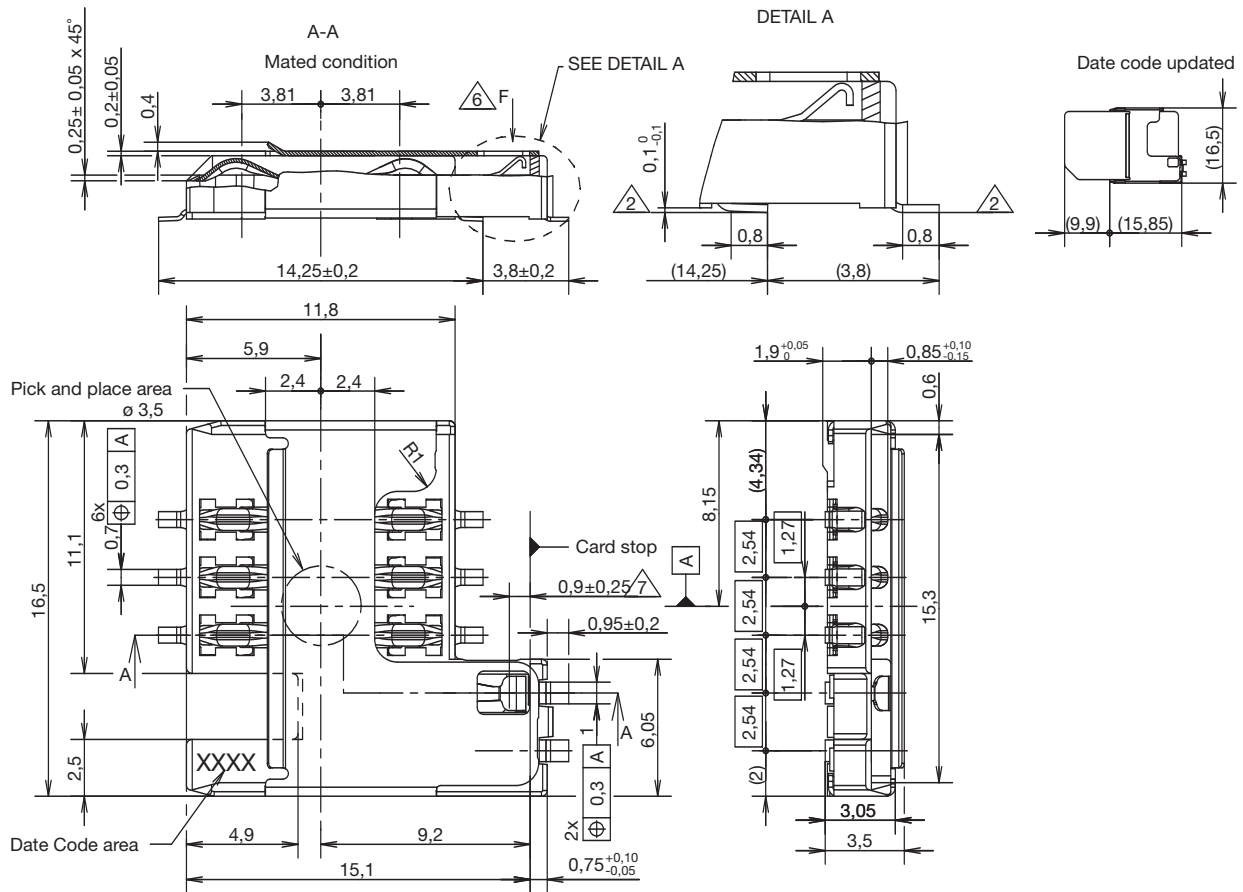

RECOMMENDED PC BOARD LAYOUT
(Component side)

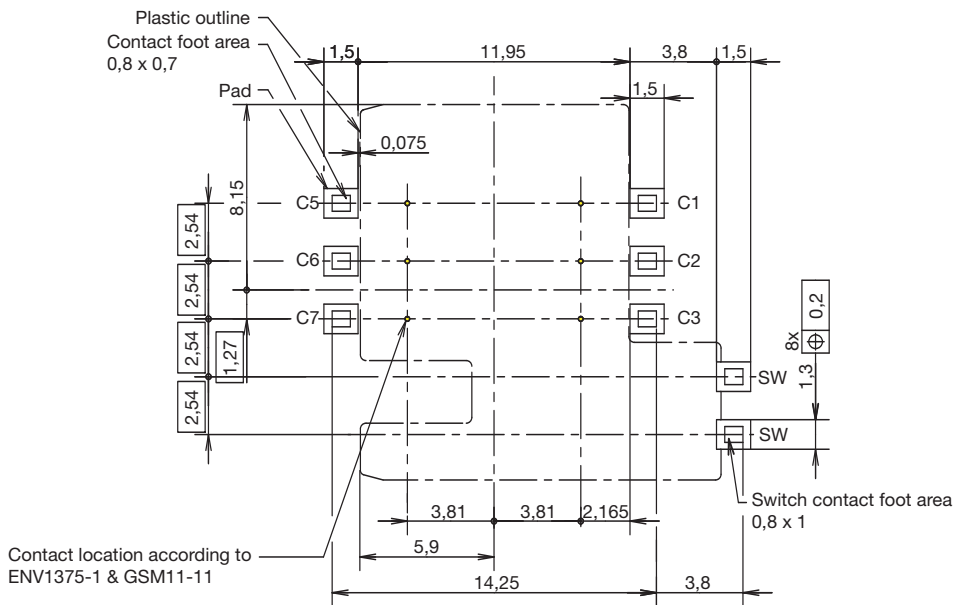

First Angle
Projection



Dimensions are shown in mm
Specifications and dimensions subject to change

CCM03-3760 LFT

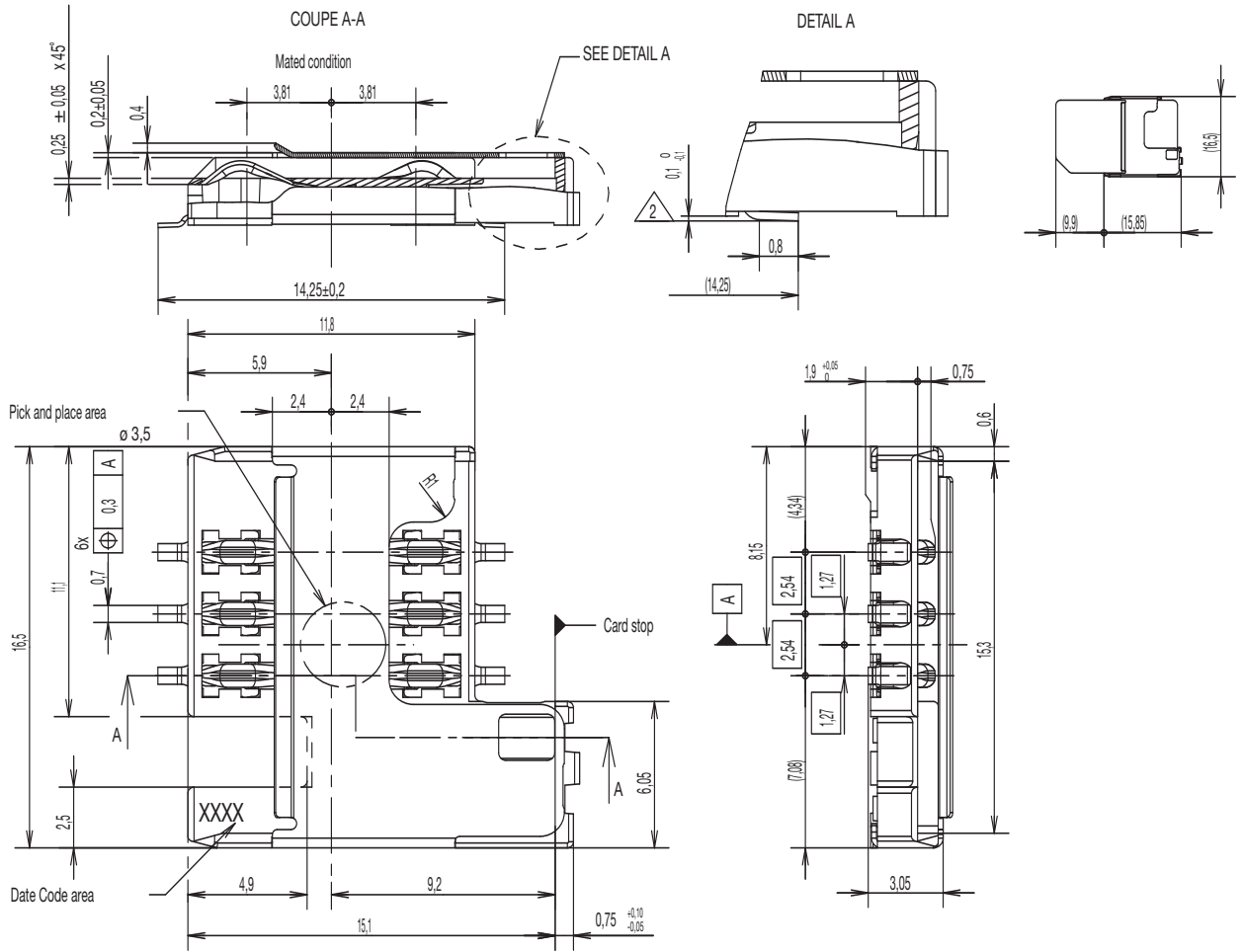

RECOMMENDED PC BOARD LAYOUT
 (Component side)

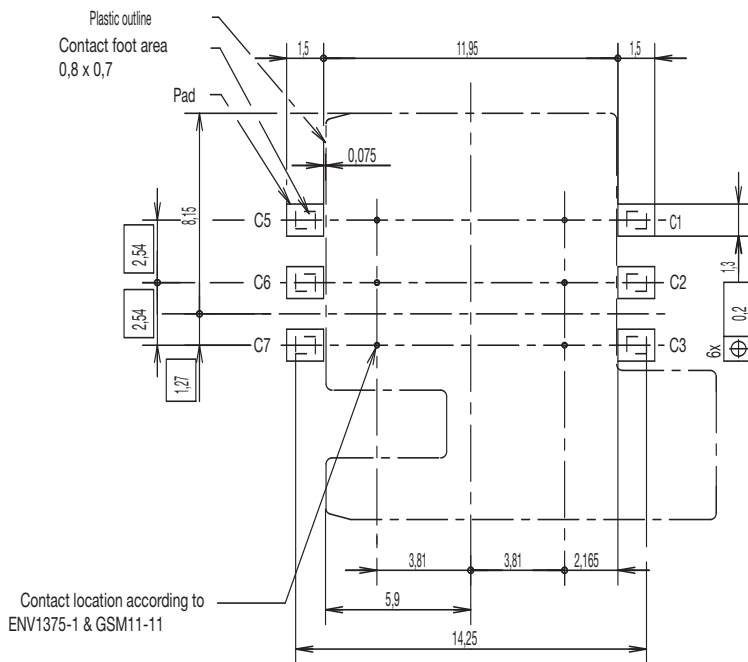

Dimensions are shown in mm
 Specifications and dimensions subject to change

CCM03 Series

CCM03-3764 LFT

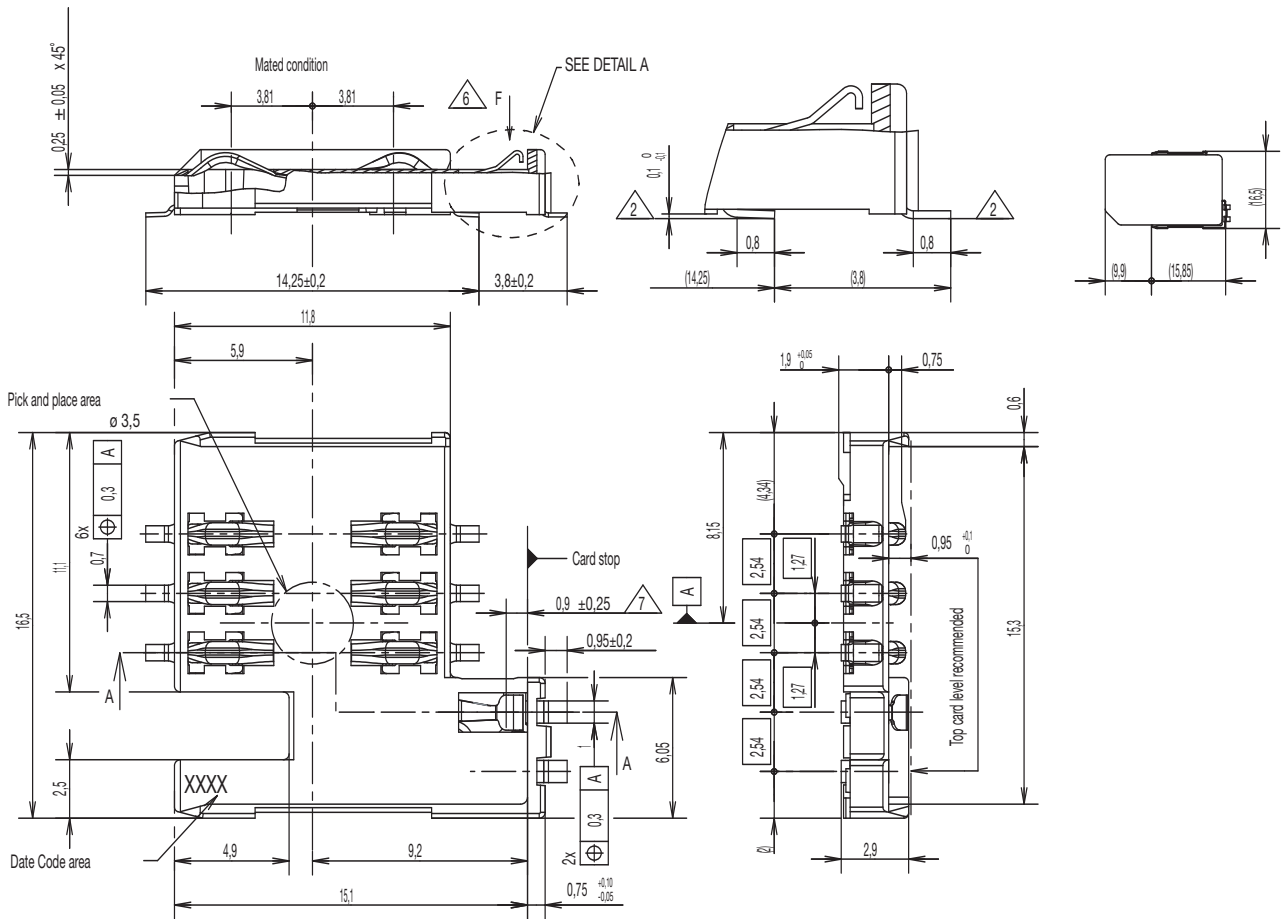

RECOMMENDED PC BOARD LAYOUT
(Component side)

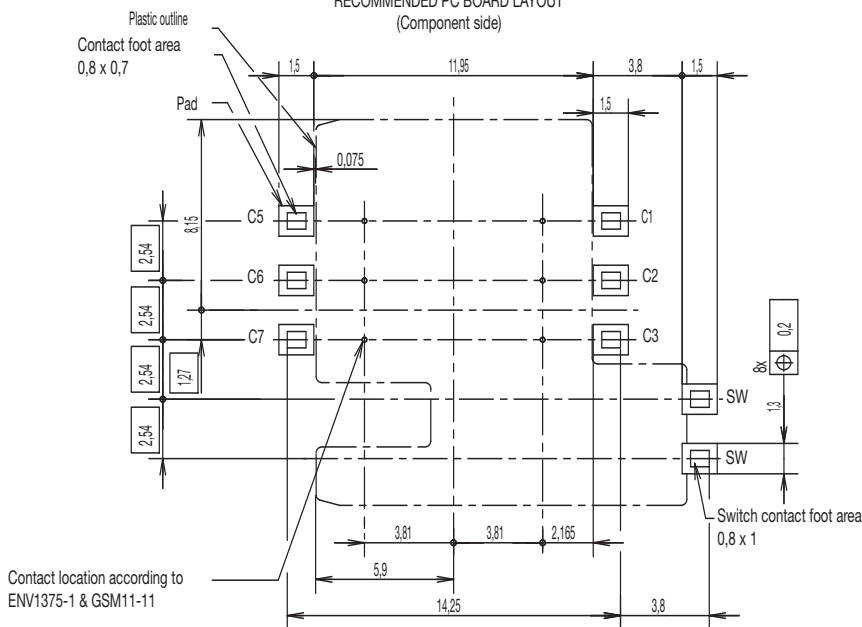

Contact location according to
ENV1375-1 & GSM11-11



First Angle
Projection

Dimensions are shown in mm
Specifications and dimensions subject to change

www.ck-components.com



AMEYA360

Components Supply Platform

Authorized Distribution Brand :



Website :

Welcome to visit www.ameya360.com

Contact Us :

➤ Address :

401 Building No.5, JiuGe Business Center, Lane 2301, Yishan Rd
Minhang District, Shanghai , China

➤ Sales :

Direct +86 (21) 6401-6692

Email amall@ameya360.com

QQ 800077892

Skype [ameyasales1](#) [ameyasales2](#)

➤ Customer Service :

Email service@ameya360.com

➤ Partnership :

Tel +86 (21) 64016692-8333

Email mkt@ameya360.com