

Octal protected low-side driver with diagnostic and serial/parallel input control

Features

- 8 channels low side driver with 450 mA output current capability
- Typical $R_{DS(ON)}$ 1.5 Ω at $T_J = 25\text{ }^\circ\text{C}$
- Parallel control for output 1 and 2
- SPI control on all outputs
- Reset function
- Diagnostic through 8 bit SPI
- Intrinsic output voltage clamping 50 V (Typ) protection for inductive load drive
- Short circuit current limitation and thermal shutdown for outputs 1 and 2
- Overcurrent and short circuit shutdown for outputs 3 to 8

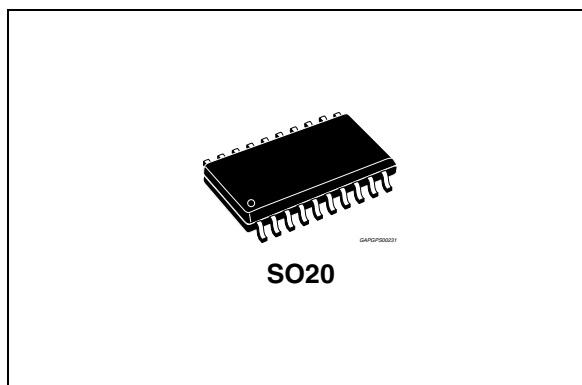

The 8-bit serial peripheral interface (SPI) is able to control the device's eight channels and to provide its load's diagnosis. In addition output 1 and 2 can also be controlled through dedicated input pins NON1 and NON2.

Overcurrent and short-circuit protections are present as well as the output voltage clamping which is able to protect the L9826 during operation with inductive loads.

Description

The L9826 is a protected octal low-side driver IC designed for the automotive environment.

Table 1. Device summary

Order code	Package	Packing
L9826	SO20	Tube
L9826TR	SO20	Tape and reel
E-L9826	SO20	Tube
E-L9826TR	SO20	Tape and reel

Contents

- 1 Block Diagram 5**
- 2 Pins description 6**
- 3 Electrical specifications 7**
 - 3.1 Absolute maximum ratings 7
 - 3.2 Thermal data 7
 - 3.3 Electrical characteristics 8
- 4 Application information 11**
- 5 Functional description 12**
 - 5.1 General 12
 - 5.2 Output stage control 12
 - 5.2.1 Via parallel, only for output 1 and 2 12
 - 5.2.2 Via 8-bit SPI for all the outputs 13
 - 5.3 Output stage diagnostics 14
 - 5.3.1 Diagnostic on Outputs 1 and 2 controlled via NON1/NON2 15
 - 5.3.2 Diagnostic on Outputs 1 to 8 controlled via SPI 15
 - 5.4 Protections 16
 - 5.4.1 Flyback current 16
 - 5.4.2 Current regulation mode outputs 1 and 2 16
 - 5.4.3 Short circuits outputs 3 to 8 16
- 6 Package information 17**
- 7 Revision history 18**

List of tables

Table 1.	Device summary	1
Table 2.	Pin description	6
Table 3.	Absolute maximum ratings for voltages and currents applied externally to the device.	7
Table 4.	Absolute maximum ratings for currents determined within the device	7
Table 5.	Thermal data.	7
Table 6.	Electrical characteristics	8
Table 7.	Outputs control tables.	12
Table 8.	Diagnostic table for outputs 1 and 2 in parallel controlled mode	15
Table 9.	Diagnostic table for outputs 1 to 8 in SPI controlled mode	15
Table 10.	Document revision history	18

List of figures

Figure 1.	Block diagram	5
Figure 2.	Connection diagram (top view)	6
Figure 3.	Typical application circuit diagram	11
Figure 4.	Parallel control for output 1 and 2 (Example for Power-on)	12
Figure 5.	Output control register structure	13
Figure 6.	Timing of the serial interface.	13
Figure 7.	The pulse diagram to read the outputs status register	14
Figure 8.	The structure of the outputs status register	14
Figure 9.	SO20 mechanical data and package dimensions.	17

1 Block Diagram

Figure 1. Block diagram

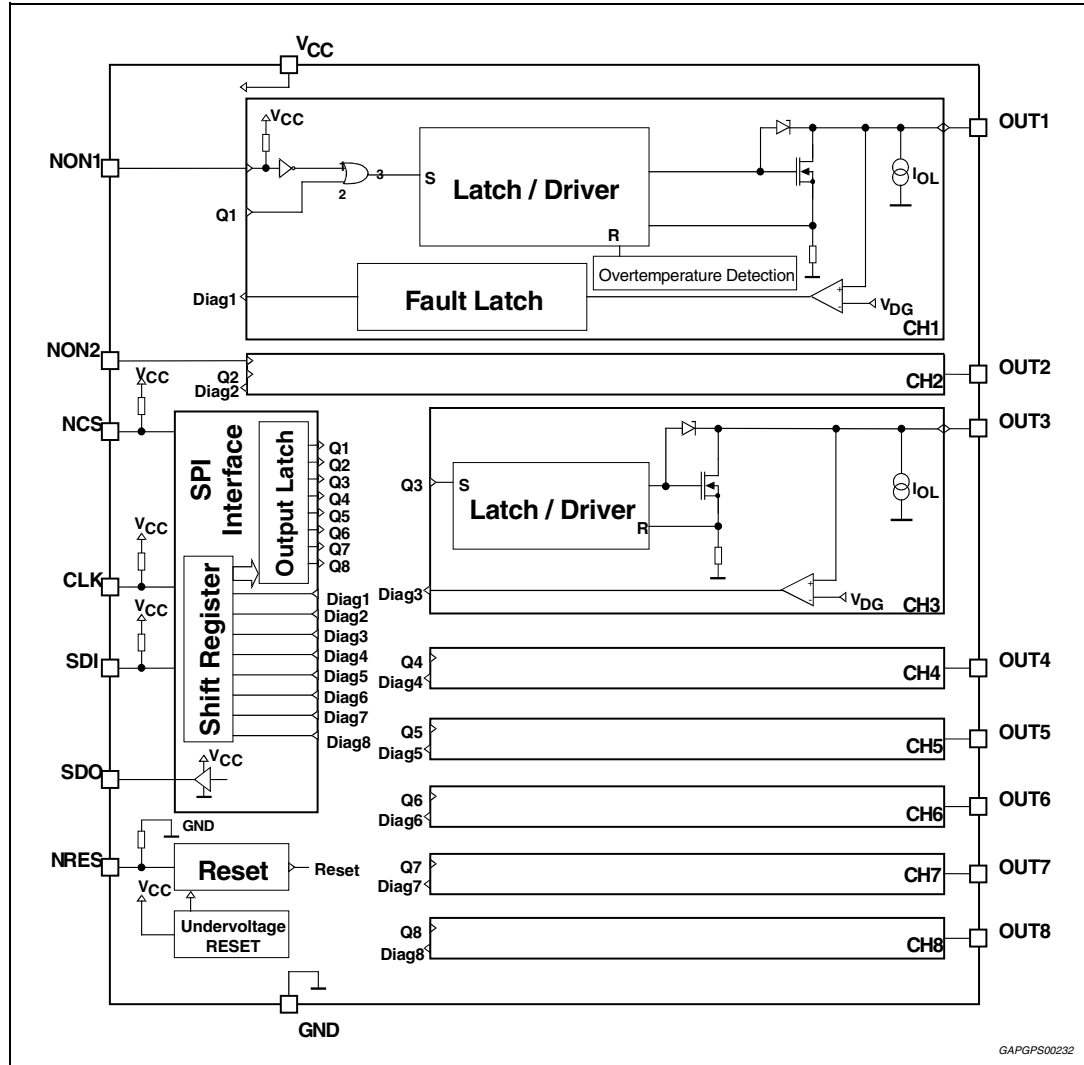

GAPGPS00232

2 Pins description

Figure 2. Connection diagram (top view)

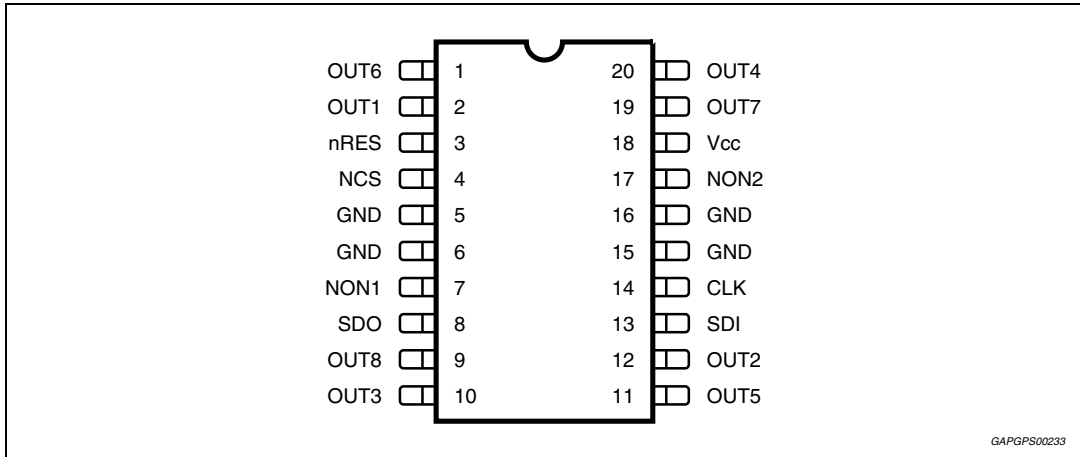

Table 2. Pin description

N°	Pin	Description
1	Out 6	Output 6
2	Out 1	Output 1
3	NRes	Asynchronous reset
4	NCS	Chip select (active low)
5	GND	Device ground
6	GND	Device ground
7	NON1	Control input 1
8	SDO	Serial data output
9	Out 8	Output 8
10	Out 3	Output 3
11	Out 5	Output 5
12	Out 2	Output 2
13	SDI	Serial data input
14	CLK	Serial clock
15	GND	Device ground
16	GND	Device ground
17	NON2	Control input 2
18	V _{CC}	Supply voltage
19	Out 7	Output 7
20	Out 4	Output 4

3 Electrical specifications

3.1 Absolute maximum ratings

Table 3. Absolute maximum ratings for voltages and currents applied externally to the device

Symbol	Parameter	Test condition	Min.	Typ.	Max.	Unit
V_{CC}	Supply voltage	-	-0.3	-	7	V
Inputs and data lines (NONx, NCS, CLK, SDI, nRes)						
V_{IN}	Voltage (NONx, NCS, CLK, SDI, nRes)		-0.3	-	7	V
I_{IN}	Protection diodes current ⁽¹⁾	$T \leq 1\text{ms}$	-20	-	20	mA
Outputs (Out1 ... Out8)						
V_{OUTc}	Continuous output voltage	-	-0.7	-	45	V
I_{OUT}	Output current ⁽²⁾	-	-2	-	1.0	A
E_{OUTcl}	Output clamp energy	$I_{OUT} \leq 150\text{mA}$	-	-	10	mJ

- All inputs are protected against ESD according to MIL 883C; tested with HBM at 2 kV. It corresponds to a dissipated energy $E \leq 0.2\text{ mJ}$.
- Transient pulses in accordance to DIN40839 part 1, 3 and ISO 7637 Part 1, 3.

Table 4. Absolute maximum ratings for currents determined within the device

Symbol	Parameter	Test condition	Min.	Typ.	Max.	Unit
Outputs (Out1 ... Out8)						
I_{OUT}	Output current (Out1, Out2)	-	-	-	I_{LIM}	A
	Output current (Out3 ... Out8)	-	-	-	I_{SCB}	A
$\sum_{i=1-8} I_{OUTi}$	Total average-current all outputs ⁽¹⁾	$T_{amb} = 60^\circ\text{C}$	2.0	-	-	A

- When operating the device with short circuit 1ch and 2ch outputs at the same time, damage due to electrical overstress might occur.

3.2 Thermal data

Table 5. Thermal data

Symbol	Parameter	Test condition	Min.	Typ.	Max.	Unit
Thermal shutdown						
T_{JSC}	Thermal shutdown threshold	-	150	165	-	$^\circ\text{C}$
Thermal resistance						
$R_{thj\ a-one}$	Single output (junction ambient)	-	-	-	90	$^\circ\text{C/W}$
$R_{thj\ a-all}$	All outputs (junction ambient)	-	-	-	75	$^\circ\text{C/W}$
$R_{thj\ pin}$	Junction to Pin	-	-	-	18	$^\circ\text{C/W}$

3.3 Electrical characteristics

Refer to $4.5\text{ V} \leq V_{CC} \leq 5.5\text{ V}$; $-40\text{ }^{\circ}\text{C} \leq T_J \leq 150\text{ }^{\circ}\text{C}$; unless otherwise specified.

Table 6. Electrical characteristics

Symbol	Parameter	Test condition	Min.	Typ.	Max.	Unit
Supply voltage						
I_{ccSTB}	Standby current	without load (nRes = Low)	-	-	70	μA
I_{ccOPM}	Operating mode	$I_{OUT1 \dots 8} = 500\text{ mA}$ SPI - CLK = 3 MHz NCS = LOW SDO no load	-	-	5	mA
ΔI_{CC}	ΔI_{CC} during reverse output current	$I_{out} = -2\text{ A}$	-	-	100	mA
V_{DDRES}	Undervoltage reset	Reset of all registers and disable of all outputs	3	-	4	V
Inputs (NONx, NCS, CLK, SDI, nRES)						
V_{INL}	Low level	-	-0.3	-	$0.2 \cdot V_{CC}$	V
V_{INH}	High level	-	$0.7 \cdot V_{CC}$	-	$V_{CC} + 0,3$	V
V_{hyst}	Hysteresis voltage	-	0.85	-	-	V
I_{IN}	Input current	NONx, NCS, CLK, SDI $V_{IN} = V_{CC}$	-	-	10	μA
		NRES ($V_{IN} = 0\text{V}$)	-10	-	-	μA
R_{IN}	Pull-up resistance	(NONx, NCS, CLK, SDI) Pull-down resistance (NRes)	50	-	250	$\text{k}\Omega$
C_{IN}	Input capacitance	Guaranteed by design	-	-	10	pF
Serial data outputs						
V_{SDOH}	High output level	$I_{SDO} = -4\text{mA}$	$V_{CC} - 0.4$	-	-	V
V_{SDOL}	Low output level	$I_{SDO} = 3,2\text{mA}$	-	-	0.4	V
I_{SDOL}	Tristate leakage current	NCS = high; $0\text{V} \leq V_{SDO} \leq V_{CC}$	-10	-	10	μA
C_{SDO}	Output capacitance	$f_{SDO} = 300\text{ kHz}$, Guaranteed by design	-	-	10	pF
Outputs OUT 1 ... 8						
$I_{OUTL1-8}$	Leakage current	OUTx = OFF; $V_{OUTx} = 25\text{ V}$; $V_{CC} = 5\text{ V}$	-	-	100	μA
		OUTx = OFF; $V_{OUTx} = 16\text{ V}$; $V_{CC} = 5\text{ V}$	-	-	100	μA
		OUTx = OFF; $V_{OUTx} = 16\text{ V}$; $V_{CC} = 1\text{ V}$	-	-	10	μA

Table 6. Electrical characteristics (continued)

Symbol	Parameter	Test condition	Min.	Typ.	Max.	Unit
V_{clp}	Output clamp voltage	$1\text{ mA} \leq I_{clp} \leq I_{outp}$; $I_{test} = 10\text{ mA}$ with correlation	45	-	62	V
R_{DSon}	On resistance OUT 1 ... 8	$I_{OUT} = 250\text{ mA}$; $T_j = +150\text{ }^\circ\text{C}$	-	-	3.0	Ω
C_{OUT}	Output capacitance	$V_{OUT} = 16\text{ V}$; $f = 1\text{ MHz}$ guaranteed by design	-	-	300	pF
Outputs short circuit protection						
I_{SBC}	Overcurrent shutoff threshold	OUT3 ... OUT8	0.45	-	1.1	A
I_{LIM}	Short circuit current limitation	OUT1; OUT2	0.5	-	1.1	A
t_{SCB}	Delay shutdown	-	0.2	3,0	12	μs
Diagnostics						
V_{DG}	Diagnostic threshold voltage	-	0.32 $\cdot V_{CC}$	-	$0.4 \cdot V_{CC}$	V
I_{OL}	Open load detection sink current	$V_{out} = V_{DG}$	20	-	100	μA
t_{df}	Diagnostic detection filter time	for output 1 & 2 on each diagnostic condition	15	-	50	μs
Outputs timing						
t_{don1}	Turn ON delay of OUT 1 and 2	NON _{1,2} = 50% to $V_{OUT} = 0,9 \cdot V_{bat}$ NCS = 50% to $V_{OUT} = 0,9 \cdot V_{bat}$ ($V_{BAT} = 16\text{V}$, $R_L = 500\Omega$)	-	-	5	μs
t_{don2}	Turn ON delay of OUT 3 to 8	NCS = 50% to $V_{OUT} = 0,9 \cdot V_{bat}$ ($V_{BAT} = 16\text{V}$, $R_L = 500\Omega$)	-	-	10	μs
t_{doff}	Turn OFF delay of OUT 1 to 8	NCS = 50% to $V_{OUT} = 0,1 \cdot V_{bat}$ NON _{1,2} = 50% to $V_{OUT} = 0,1 \cdot V_{bat}$ ($V_{BAT} = 16\text{V}$, $R_L = 500\Omega$)	-	-	10	μs
$dU_{on1/dt}$	Turn ON voltage slew-rate	For output 3 to 8; 90% to 30% of V_{bat} ; $R_L = 500\Omega$; $V_{bat} = 16\text{V}$	0.7	-	3.5	$\text{V}/\mu\text{s}$
$dU_{on2/dt}$	Turn ON voltage slew-rate	For output 1 and 2; 90% to 30% of V_{bat} ; $R_L = 500\Omega$; $V_{bat} = 16\text{V}$	2	-	10	$\text{V}/\mu\text{s}$
$dU_{off1/dt}$	Turn OFF voltage slew-rate	For output 1 to 8; 30% to 90% of V_{bat} ; $R_L = 500\Omega$; $V_{bat} = 16\text{V}$	2	-	10	$\text{V}/\mu\text{s}$
$dU_{off2/dt}$	Turn OFF voltage slew-rate	For output 1 to 8; 30% to 80% of V_{bat} ; $R_L = 500\Omega$; $V_{bat} = 0,9 \cdot V_{clp}$	2	-	15	$\text{V}/\mu\text{s}$
Serial diagnostic link (load capacitor at SDO = 100 pF)						
f_{clk}	Clock frequency	50 % duty cycle	-	-	3	MHz
t_{clh}	Minimum time CLK = high	-	160	-	-	ns
t_{cll}	Minimum time CLK = low	-	160	-	-	ns
t_{pcld}	Propagation delay CLK to data at SDO valid	$4.9\text{ V} \leq V_{CC} \leq 5.1\text{ V}$	-	-	100	ns

Table 6. Electrical characteristics (continued)

Symbol	Parameter	Test condition	Min.	Typ.	Max.	Unit
t_{csdv}	NCS = LOW to data at SDO active	-	-	-	100	ns
t_{sclch}	CLK low before NCS low	Setup time CLK to NCS change H/L	100	-	-	ns
t_{hclcl}	CLK change L/H after NCS = low	-	100	-	-	ns
t_{sclcl}	SDI input setup time	CLK change H/L after SDI data valid	20	-	-	ns
t_{hclcl}	SDI input hold time	SDI data hold after CLK change H/L	-	-	20	ns
t_{sclcl}	CLK low before NCS high	-	150	-	-	ns
t_{hclch}	CLK high after NCS high	-	150	-	-	ns
t_{pchdz}	NCS L/H to output data float	-	-	-	100	ns
-	NCS pulse filter time	Multiple of 8 CLK cycles inside NCS period	-	-	-	-

4 Application information

The typical application diagram is shown in *Figure 3*.

Figure 3. Typical application circuit diagram

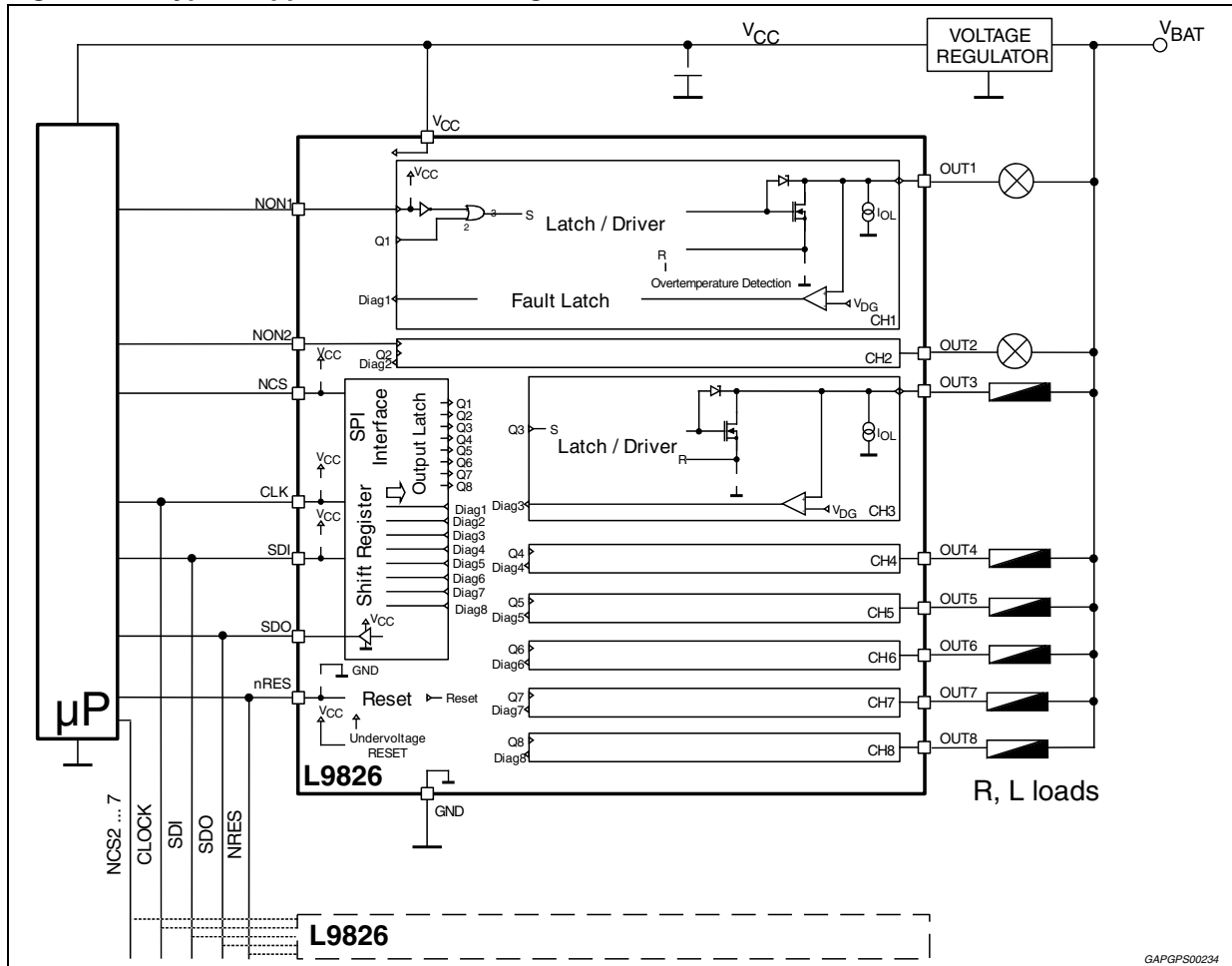

For higher current capability the two outputs of the same kind can be paralleled and the maximum flyback energy should not exceed the limit for a single output.

The circuit immunity at output transients have been verified during the characterization with Test Pulses 1, 2, 3a and 3b, DIN40839 or ISO7637 part 3.

The Test Pulses are coupled to the outputs with 200 pF series capacitor and all the outputs are able to withstand to test pulses without damage. The load applied was in the range of 30 to 100 ohm for the resistive part and 0 to 600 mH for the inductive one.

5 Functional description

5.1 General

The L9826 is an 8-channel low-side driver assembled in SO20 package. Its 8-bit SPI serial interface is designed to control all the outputs and to provide their diagnosis. Channels 1 and 2 are controlled either via SPI or via parallel through the inputs pins NON1 and NON2. Diagnostic recognizes operative fault conditions: open load, short circuits to GND or to VB and overcurrent. Thermal shutdown for outputs 1 and 2 is available as well the output voltage clamp which is essential in case of working with inductive loads.

The reset feature is an OR function of the external reset nRes and the internal reset generate during the undervoltage condition

5.2 Output stage control

5.2.1 Via parallel, only for output 1 and 2

This is valid only for Outputs 1 and 2 which are controlled through the dedicated inputs NON1 and NON2 (both active low) which are internally configured as pull-up (see [Figure 3](#)). This is to guarantee that the outputs are off in case of inputs open.

A further feature is the possibility to drive these outputs through a PWM signal independently by SPI commands.

Reset signal is common for all the eight channels and it is active low. After an external reset condition (that means NRES pin switched from low to high) to drive outputs 1 and 2 through the parallel input (NON1 and NON2) it is necessary to disable the parallel input itself (NON1, NON2 high) and then subsequently to drive the outputs 1 and 2 at the logic state desiderated through NON1 and NON2. The duration of the command (T) as reported in the [Figure 4](#) should be at less in the order of 100 nSecond.

In the next [Figure 4](#) is shown this behavior and in the next [Table 7](#) is summarized the scenario of parallel/series commands.

Figure 4. Parallel control for output 1 and 2 (Example for Power-on)

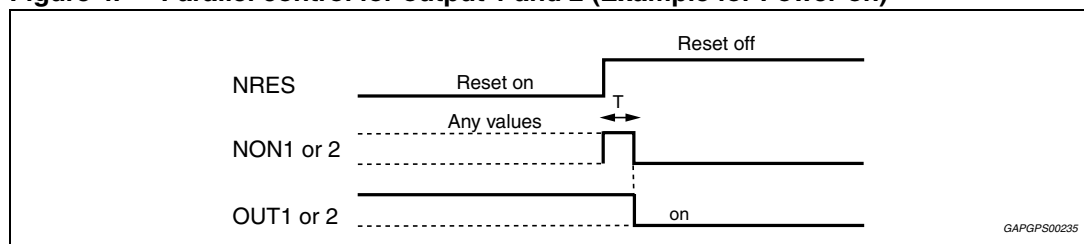

Table 7. Outputs control tables

Outputs 1, 2:					Outputs 3 to 8:		
NON1, 2	1	0	0	1	-	-	-
SPI-bit 1, 2	0	0	1	1	SPI-bit 3 ... 8	0	1
Output 1, 2	off	on	on	on	Output 3 ... 8	off	on

5.2.2 Via 8-bit SPI for all the outputs

Control data are transmitted to SDI through a microcontroller in configuration master. The device is selected when NCS signal is low. The 8-bit command data are transmitted into L9826 shift registers every CLK falling edge (see [Figure 6](#) for SPI signals timing).

The NCS rising edge latches the new data from the shift register to the driver and the output are driven following the commands just sent.

The digital filter between NCS and the output latch ensures that the data are transferred only after 8 CLK cycles or multiple of 8 CLK cycles since the last NCS falling edge.

The NCS changes only at low CLK.

[Figure 5](#) shows the control register structure and in the detail its control-bit, while in the [Table 7](#) are summarized the controls outputs via SPI or dedicated input pins (NON1 and NON2).

Figure 5. Output control register structure

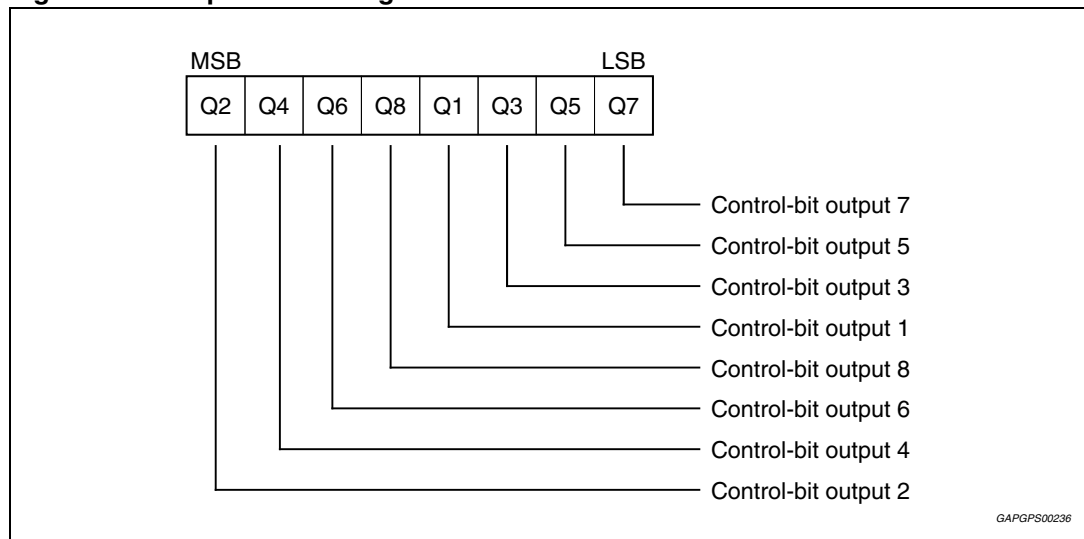
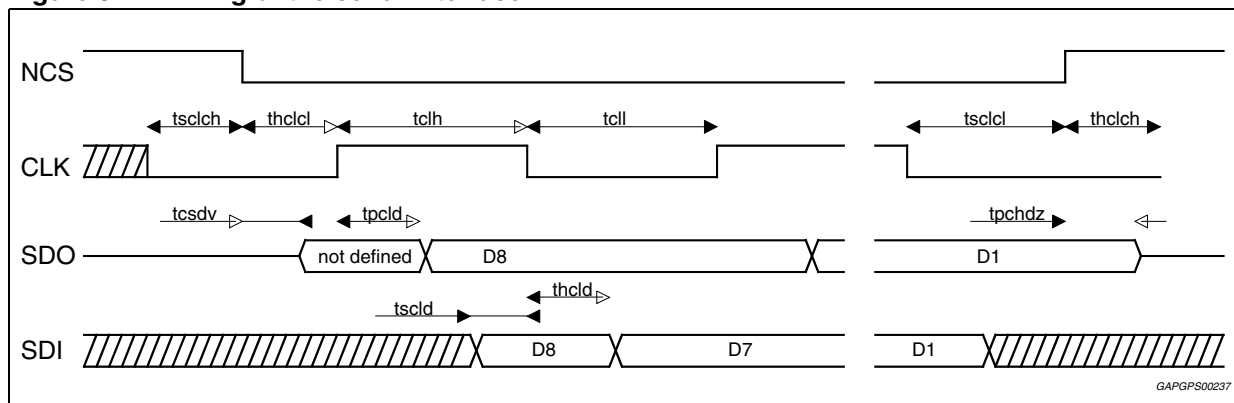

Figure 6. Timing of the serial interface



5.3 Output stage diagnostics

All the outputs voltage are compared with the diagnostic threshold (0.38 Typ · VCC) and this information is transferred in dedicated fault latches which are cleared when the NCS reaches the state low. Afterward the latch stores the status bit and the first reading after the error might be wrong. The second one is considered right.

The next *Figure 7* and *8* show the diagnostic bits read out on SDO and their organization into the dedicated registers.

When NCS is low the data contained in the shift register are transferred to SDO output every CLK rising edge.

Figure 7. The pulse diagram to read the outputs status register

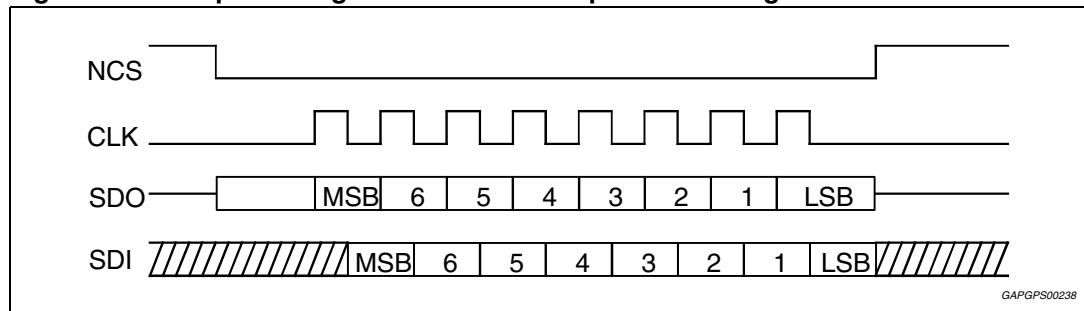
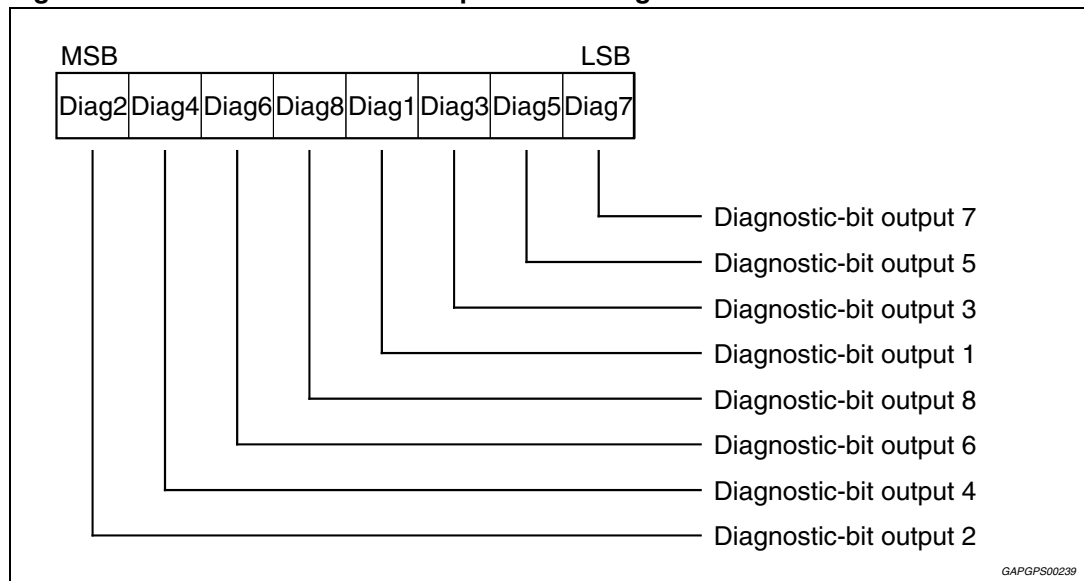

Figure 8. The structure of the outputs status register



5.3.1 Diagnostic on Outputs 1 and 2 controlled via NON1/NON2

Fault condition (1) "output shorted to Vbat"

The output has been previously switched-on and its voltage exceeds the diagnostics threshold. It operates in current regulation mode or it is switched-off if thermal shutdown threshold (T_{JSC}) is reached. The status bit is low.

Fault condition (2) "open load" or "output shorted to GND"

The output is switched-off and its voltage drops below the diagnostics threshold because the load current is lower than the output diagnostic current source. The diagnostic bit is low.

Table 8. Diagnostic table for outputs 1 and 2 in parallel controlled mode

Output 1, 2	Output-voltage	Status-bit	Output-mode
off	> DG-threshold	high	correct operation
off	< DG-threshold	low	fault condition 2)
on	< DG-threshold	high	correct operation
on	> DG-threshold	low	fault condition 1)

5.3.2 Diagnostic on Outputs 1 to 8 controlled via SPI

Fault condition (1) "output shorted to Vbat"

The output was previously switched-on, its voltage exceeds the diagnostic threshold and the result is that the output is switched-off. The diagnostic bit is high.

Fault condition (2) "open load" or "output shorted to GND"

It is the same behavior explained for the outputs 1 and 2 (see paragraph 5.3.1), at NCS falling edge the output status data are transferred to the shift register.

Table 9. Diagnostic table for outputs 1 to 8 in SPI controlled mode

Output 1 ... 8	Output-voltage	Status-bit	Output-mode
off	> DG-threshold	high	correct operation
off	< DG-threshold	low	fault condition 2)
on	< DG-threshold	low	correct operation
on	> DG-threshold	high	fault condition 1)

Load diagnostic: when the output is in OFF condition a typical diagnostic current of 60 μ A is sinked.

5.4 Protections

5.4.1 Flyback current

Turning off the low side driver with an inductive load, its output voltage rises due to the inductor that tries to drive current. This voltage is internally clamped by the flyback circuit at V_{CPL} value, typical 50V

5.4.2 Current regulation mode outputs 1 and 2

Outputs 1 and 2 which are particularly dedicated for loads with inrush current (as lamps). When the channel is switched on and the current through the load exceeds the short circuit limit value (I_{lim}) for at least t_{df} time, the corresponding output goes in current regulation mode.

The output current is determined by the output characteristic and its voltage depends on load resistance. In this mode, high power is dissipated in the output stage and its temperature increases rapidly. When the output stage temperature exceeds the thermal shutdown (T_{JSC}), the overload latch is set and the corresponding output is switched off.

5.4.3 Short circuits outputs 3 to 8

Outputs 3 to 8 which are dedicated for loads without inrush currents. When the output current exceeds the short circuit threshold (I_{sbc}) for at least T_{scb} time, the corresponding output is switched-off immediately and in the same time, the relative latch store the overload status.

6 Package information

In order to meet environmental requirements, ST offers these devices in different grades of ECOPACK[®] packages, depending on their level of environmental compliance. ECOPACK[®] specifications, grade definitions and product status are available at: www.st.com.

ECOPACK[®] is an ST trademark.

Figure 9. SO20 mechanical data and package dimensions

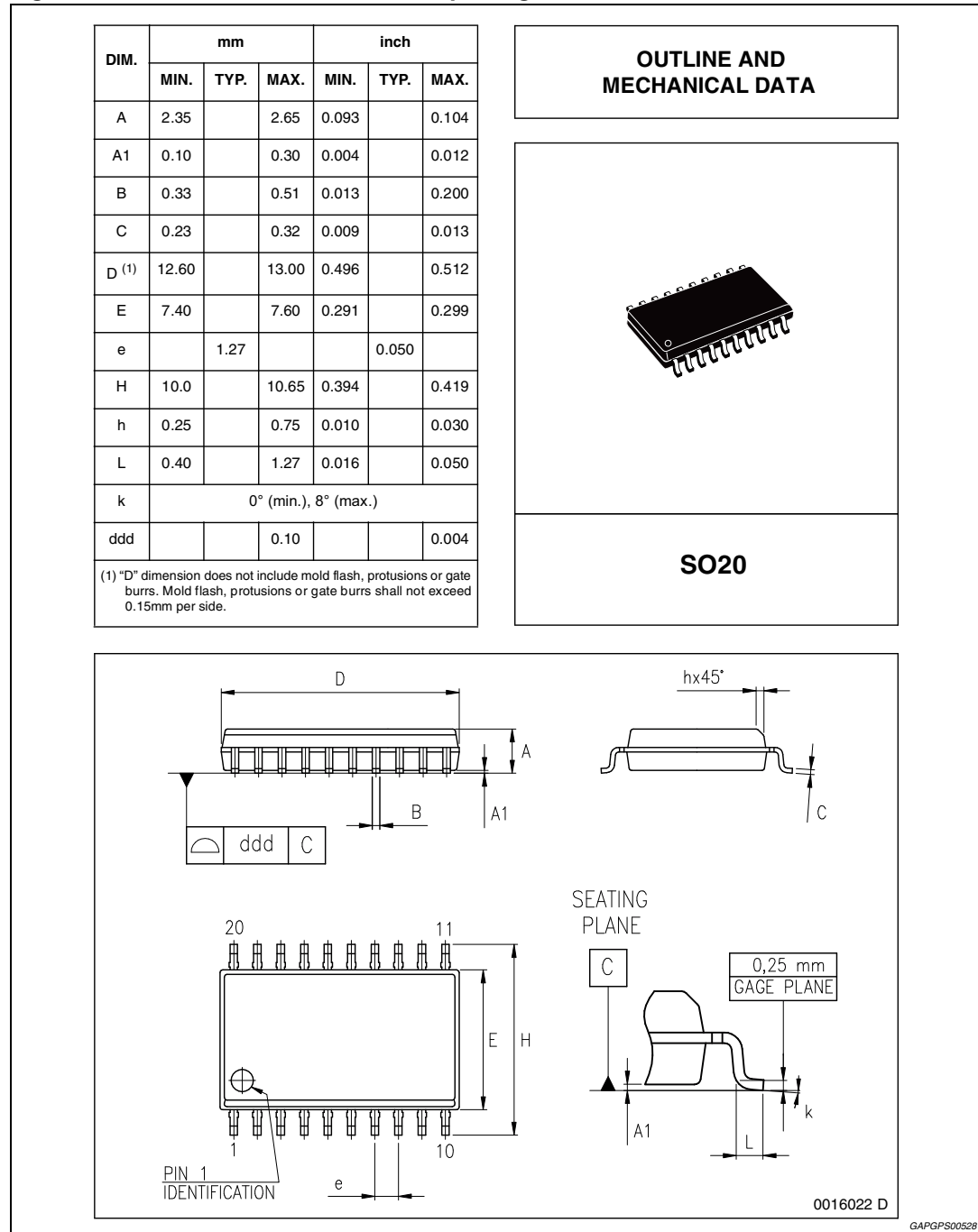

7 Revision history

Table 10. Document revision history

Date	Revision	Changes
22-Apr-2004	7	Initial release in EDOCS
26-Jul-2005	8	Document reformatted. Modify value R_{ON} in the "Features".
08-Feb-2011	9	Updated <i>Features</i> and <i>Description on page 1</i> . Updated <i>Table 1: Device summary on page 1</i> . Updated <i>Figure 3: Typical application circuit diagram</i> . Reworked the content of the <i>Section 5: Functional description</i> .
19-Sep-2013	10	Updated Disclaimer.

Please Read Carefully:

Information in this document is provided solely in connection with ST products. STMicroelectronics NV and its subsidiaries ("ST") reserve the right to make changes, corrections, modifications or improvements, to this document, and the products and services described herein at any time, without notice.

All ST products are sold pursuant to ST's terms and conditions of sale.

Purchasers are solely responsible for the choice, selection and use of the ST products and services described herein, and ST assumes no liability whatsoever relating to the choice, selection or use of the ST products and services described herein.

No license, express or implied, by estoppel or otherwise, to any intellectual property rights is granted under this document. If any part of this document refers to any third party products or services it shall not be deemed a license grant by ST for the use of such third party products or services, or any intellectual property contained therein or considered as a warranty covering the use in any manner whatsoever of such third party products or services or any intellectual property contained therein.

UNLESS OTHERWISE SET FORTH IN ST'S TERMS AND CONDITIONS OF SALE ST DISCLAIMS ANY EXPRESS OR IMPLIED WARRANTY WITH RESPECT TO THE USE AND/OR SALE OF ST PRODUCTS INCLUDING WITHOUT LIMITATION IMPLIED WARRANTIES OF MERCHANTABILITY, FITNESS FOR A PARTICULAR PURPOSE (AND THEIR EQUIVALENTS UNDER THE LAWS OF ANY JURISDICTION), OR INFRINGEMENT OF ANY PATENT, COPYRIGHT OR OTHER INTELLECTUAL PROPERTY RIGHT.

ST PRODUCTS ARE NOT DESIGNED OR AUTHORIZED FOR USE IN: (A) SAFETY CRITICAL APPLICATIONS SUCH AS LIFE SUPPORTING, ACTIVE IMPLANTED DEVICES OR SYSTEMS WITH PRODUCT FUNCTIONAL SAFETY REQUIREMENTS; (B) AERONAUTIC APPLICATIONS; (C) AUTOMOTIVE APPLICATIONS OR ENVIRONMENTS, AND/OR (D) AEROSPACE APPLICATIONS OR ENVIRONMENTS. WHERE ST PRODUCTS ARE NOT DESIGNED FOR SUCH USE, THE PURCHASER SHALL USE PRODUCTS AT PURCHASER'S SOLE RISK, EVEN IF ST HAS BEEN INFORMED IN WRITING OF SUCH USAGE, UNLESS A PRODUCT IS EXPRESSLY DESIGNATED BY ST AS BEING INTENDED FOR "AUTOMOTIVE, AUTOMOTIVE SAFETY OR MEDICAL" INDUSTRY DOMAINS ACCORDING TO ST PRODUCT DESIGN SPECIFICATIONS. PRODUCTS FORMALLY ESCC, QML OR JAN QUALIFIED ARE DEEMED SUITABLE FOR USE IN AEROSPACE BY THE CORRESPONDING GOVERNMENTAL AGENCY.

Resale of ST products with provisions different from the statements and/or technical features set forth in this document shall immediately void any warranty granted by ST for the ST product or service described herein and shall not create or extend in any manner whatsoever, any liability of ST.

ST and the ST logo are trademarks or registered trademarks of ST in various countries.

Information in this document supersedes and replaces all information previously supplied.

The ST logo is a registered trademark of STMicroelectronics. All other names are the property of their respective owners.

© 2013 STMicroelectronics - All rights reserved

STMicroelectronics group of companies

Australia - Belgium - Brazil - Canada - China - Czech Republic - Finland - France - Germany - Hong Kong - India - Israel - Italy - Japan - Malaysia - Malta - Morocco - Philippines - Singapore - Spain - Sweden - Switzerland - United Kingdom - United States of America

www.st.com

AMEYA360

Components Supply Platform

Authorized Distribution Brand :



Website :

Welcome to visit www.ameya360.com

Contact Us :

➤ Address :

401 Building No.5, JiuGe Business Center, Lane 2301, Yishan Rd
Minhang District, Shanghai , China

➤ Sales :

Direct +86 (21) 6401-6692

Email amall@ameya360.com

QQ 800077892

Skype [ameyasales1](#) [ameyasales2](#)

➤ Customer Service :

Email service@ameya360.com

➤ Partnership :

Tel +86 (21) 64016692-8333

Email mkt@ameya360.com