

### Atmel QT1 Xplained Pro

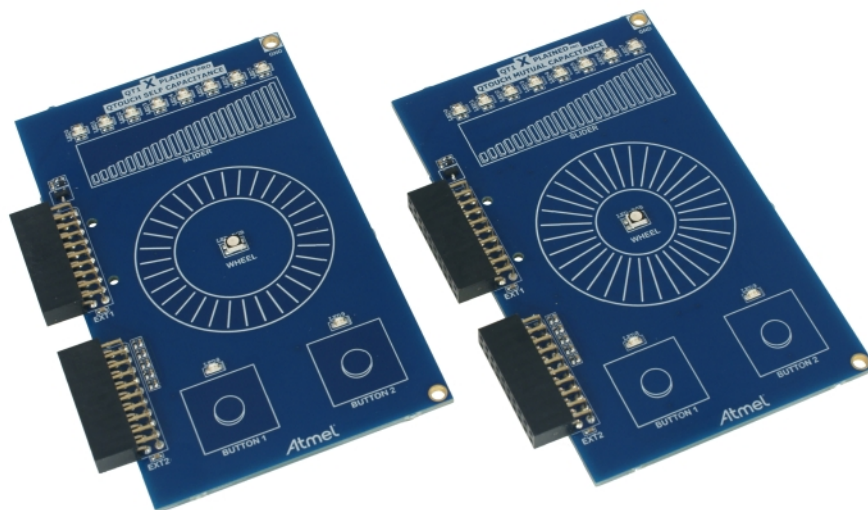

## Preface

Atmel® QT1 Xplained Pro kit is an extension board that enables evaluation of self- and mutual capacitance mode using the Peripheral Touch Controller (PTC) module. The kit shows how easy it is to design a capacitive touch board solution for the PTC without the need for any external components. The kit includes two boards, one using self capacitance (SC) and one using mutual capacitance (MC).

## Table of Contents

---

Preface .....	1
<b>1. Introduction .....</b>	<b>3</b>
1.1. Features .....	3
1.2. Kit Overview .....	3
<b>2. Getting started .....</b>	<b>5</b>
2.1. Three Steps to Start Exploring the Atmel Xplained Pro Platform .....	5
2.2. Connecting QT1 Xplained Pro to the Xplained Pro MCU board. ....	5
2.3. Design Documentation and Related Links .....	5
<b>3. Xplained Pro .....</b>	<b>6</b>
3.1. Hardware Identification System .....	6
3.2. Standard Headers and Connectors .....	6
3.2.1. Xplained Pro Standard Extension Header .....	6
<b>4. Hardware User Guide .....</b>	<b>8</b>
4.1. Headers and Connectors .....	8
4.1.1. QT1 Xplained Pro MC Extension Headers .....	8
4.1.2. QT1 Xplained Pro SC Extension Headers .....	9
4.1.3. Peripherals .....	10
<b>5. Hardware Revision History and Known Issues .....</b>	<b>11</b>
5.1. Identifying Product ID and Revision .....	11
5.2. Revision 3 .....	11
<b>6. Document Revision History .....</b>	<b>12</b>
<b>7. Evaluation Board/Kit Important Notice .....</b>	<b>13</b>

# 1. Introduction

## 1.1 Features

- QTouch®<sup>1</sup>
  - Two buttons
  - One slider
  - One wheel
- LEDs<sup>1</sup>
  - One LED for each button
  - Eight LEDs for the slider
  - One RGB LED for the wheel
- Xplained Pro hardware identification system<sup>1</sup>

## 1.2 Kit Overview

Atmel QT1 Xplained Pro extension kit is a set of two extension boards designed specifically for Xplained Pro MCU boards featuring a MCU with a built-in peripheral touch controller.

The extension boards can be used to explore the touch functions on the PTC module in both mutual capacitance (MC) mode and self capacitance (SC) mode.

Figure 1-1. QT1 Xplained Pro MC Extension Board

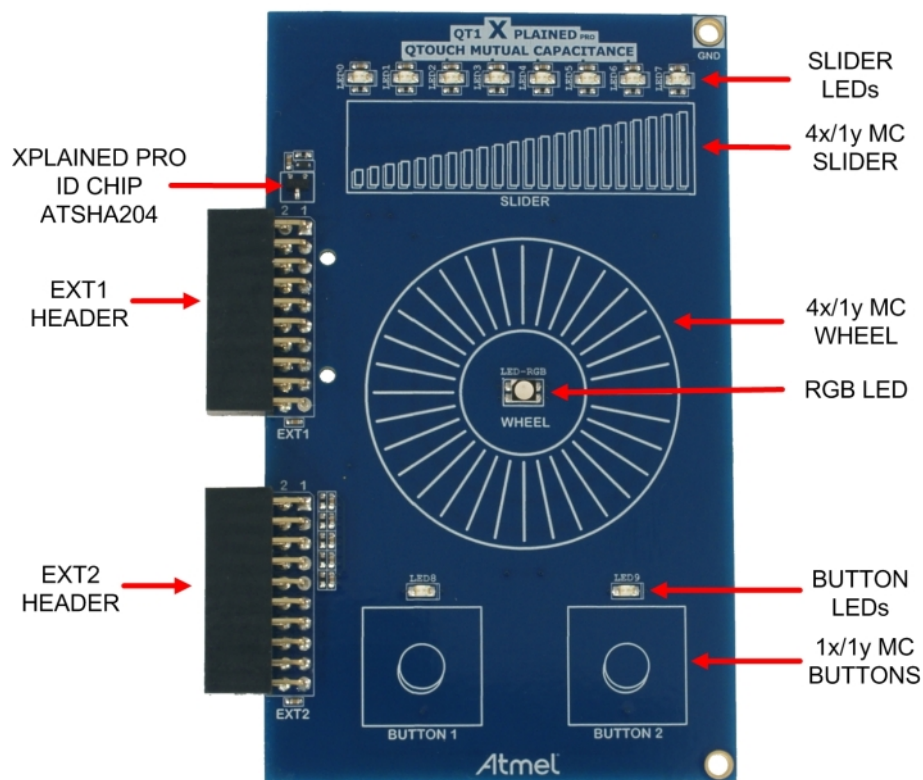

<sup>1</sup>Applies to both mutual capacitance and self capacitance board.

Figure 1-2. QT1 Xplained Pro SC Extension Board

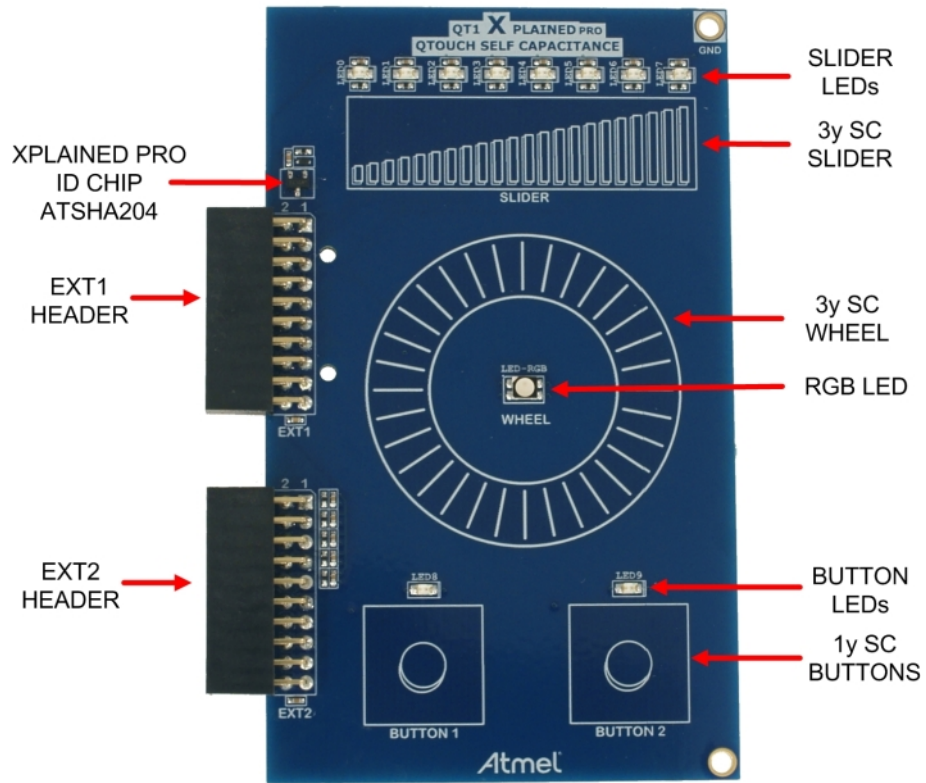

## 2. Getting started

### 2.1 Three Steps to Start Exploring the Atmel Xplained Pro Platform

1. Download and install [Atmel Studio](#).
2. Launch Atmel Studio.
3. Connect QT1 Xplained Pro to an Xplained Pro MCU board and connect a USB cable to DEBUG USB port on the Xplained Pro MCU board.

### 2.2 Connecting QT1 Xplained Pro to the Xplained Pro MCU board.

Atmel QT1 Xplained Pro has been designed to be connected to the header marked EXT1 and EXT2 on the Xplained Pro MCU board.

Development of touch applications will require that you download and install the [Atmel QTouch Library](#) and [Atmel QTouch Composer](#) from the extension gallery in [Atmel Studio](#).

Once the Xplained Pro MCU board is powered the green power LED will be lit and Atmel Studio will auto detect which Xplained Pro MCU- and extension board(s) that is connected. You will be presented with relevant information like datasheets and kit documentation. You also have the option to launch Atmel Software Framework (ASF) example applications. The target device is programmed and debugged by the on-board Embedded Debugger. No external programmer or debugger tool is needed.

### 2.3 Design Documentation and Related Links

The following list contains links to the most relevant documents and software for QT1 Xplained Pro.

1. [Xplained Pro products](#)<sup>1</sup> - Atmel Xplained Pro is a series of small-sized and easy-to-use evaluation kits for 8- and 32-bit Atmel microcontrollers. It consists of a series of low cost MCU boards for evaluation and demonstration of features and capabilities of different MCU families.
2. [QT1 Xplained Pro User Guide](#)<sup>2</sup> - PDF version of this User Guide.
3. [QT1 Xplained Pro Design Documentation](#)<sup>3</sup> - Package containing schematics, BOM, assembly drawings, 3D plots, layer plots etc.
4. [Atmel QTouch Library](#)<sup>4</sup> - QTouch Library to support Atmel AVR and ARM<sup>®</sup>-based microcontrollers.
5. [Atmel QTouch Composer](#)<sup>5</sup> - Tool for developing capacitive buttons, sliders and wheels applications.
6. [Atmel Studio](#)<sup>6</sup> - Free Atmel IDE for development of C/C++ and assembler code for Atmel microcontrollers.

<sup>1</sup> <http://www.atmel.com/XplainedPro>

<sup>2</sup> [http://www.atmel.com/Images/Atmel-42193-Qt1-Xplained-Pro\\_User-Guide.pdf](http://www.atmel.com/Images/Atmel-42193-Qt1-Xplained-Pro_User-Guide.pdf)

<sup>3</sup> [http://www.atmel.com/Images/Atmel-42193-Qt1-Xplained-Pro\\_User-Guide.zip](http://www.atmel.com/Images/Atmel-42193-Qt1-Xplained-Pro_User-Guide.zip)

<sup>4</sup> <http://www.atmel.com/tools/QTOUCHLIBRARY.aspx>

<sup>5</sup> [http://www.atmel.com/tools/atmel\\_qtouch.aspx](http://www.atmel.com/tools/atmel_qtouch.aspx)

<sup>6</sup> <http://www.atmel.com/atmelstudio>

## 3. Xplained Pro

Xplained Pro is an evaluation platform that provides the full Atmel microcontroller experience. The platform consists of a series of Microcontroller (MCU) boards and extension boards that are integrated with Atmel Studio, have Atmel Software Framework (ASF) drivers and demo code, support data streaming and more. Xplained Pro MCU boards support a wide range of Xplained Pro extension boards that are connected through a set of standardized headers and connectors. Each extension board has an identification (ID) chip to uniquely identify which boards are mounted on a Xplained Pro MCU board. This information is used to present relevant user guides, application notes, datasheets and example code through Atmel Studio. Available Xplained Pro MCU and extension boards can be purchased in the [Atmel Web Store](#)<sup>1</sup>.

### 3.1 Hardware Identification System

All Xplained Pro compatible extension boards have an Atmel ATSHA204 CryptoAuthentication™ chip mounted. This chip contains information that identifies the extension with its name and some extra data. When an Xplained Pro extension board is connected to an Xplained Pro MCU board the information is read and sent to Atmel Studio. The Atmel Kits extension, installed with Atmel Studio, will give relevant information, code examples and links to relevant documents. [Table 3-1, “Xplained Pro ID Chip Content” on page 6](#) shows the data fields stored in the ID chip with example content.

**Table 3-1. Xplained Pro ID Chip Content**

Data Field	Data Type	Example Content
Manufacturer	ASCII string	Atmel'\0'
Product Name	ASCII string	Segment LCD1 Xplained Pro'\0'
Product Revision	ASCII string	02'\0'
Product Serial Number	ASCII string	1774020200000010'\0'
Minimum Voltage [mV]	uint16_t	3000
Maximum Voltage [mV]	uint16_t	3600
Maximum Current [mA]	uint16_t	30

### 3.2 Standard Headers and Connectors

#### 3.2.1 Xplained Pro Standard Extension Header

All Xplained Pro kits have one or more dual row, 20-pin, 100mil extension headers. Xplained Pro MCU boards have male headers while Xplained Pro extensions have their female counterparts. Note that all pins are not always connected. However, all the connected pins follow the defined pin-out described in [Table 3-2, “Xplained Pro Extension Header” on page 6](#). The extension headers can be used to connect a wide variety of Xplained Pro extensions to Xplained Pro MCU boards and to access the pins of the target MCU on Xplained Pro MCU board directly.

**Table 3-2. Xplained Pro Extension Header**

Pin number	Name	Description
1	ID	Communication line to the ID chip on extension board.
2	GND	Ground.
3	ADC(+)	Analog to digital converter , alternatively positive part of differential ADC.
4	ADC(-)	Analog to digital converter , alternatively negative part of differential ADC.
5	GPIO1	General purpose I/O.
6	GPIO2	General purpose I/O.
7	PWM(+)	Pulse width modulation , alternatively positive part of differential PWM.
8	PWM(-)	Pulse width modulation , alternatively positive part of differential PWM.

<sup>1</sup> <http://store.atmel.com/CBC.aspx?q=c:100113>

Pin number	Name	Description
9	IRQ/GPIO	Interrupt request line and/or general purpose I/O.
10	SPI_SS_B/GPIO	Slave select for SPI and/or general purpose I/O.
11	TWI_SDA	Data line for two-wire interface. Always implemented, bus type.
12	TWI_SCL	Clock line for two-wire interface. Always implemented, bus type.
13	USART_RX	Receiver line of Universal Synchronous and Asynchronous serial Receiver and Transmitter.
14	USART_TX	Transmitter line of Universal Synchronous and Asynchronous serial Receiver and Transmitter.
15	SPI_SS_A	Slave select for SPI. Should be unique if possible.
16	SPI_MOSI	Master out slave in line of Serial peripheral interface. Always implemented, bus type.
17	SPI_MISO	Master in slave out line of Serial peripheral interface. Always implemented, bus type.
18	SPI_SCK	Clock for Serial peripheral interface. Always implemented, bus type.
19	GND	Ground.
20	VCC	Power for extension board.

## 4. Hardware User Guide

### 4.1 Headers and Connectors

#### 4.1.1 QT1 Xplained Pro MC Extension Headers

QT1 Xplained Pro MC implements two [Xplained Pro Standard Extension Header on page 6](#) marked with EXT1 and EXT2 in silkscreen. These headers makes it possible to connect the board to a Xplained Pro MCU board with a MCU featuring a PTC module. The pin-out definition for the extension headers can be seen in [Table 4-1, “QT1 Xplained Pro MC Extension Header 1” on page 8](#) and [Table 4-2, “QT1 Xplained Pro MC Extension Header 2” on page 8](#).

**Table 4-1. QT1 Xplained Pro MC Extension Header 1**

Pin on EXT	Function	Description
1	ID	Communication line to ID chip.
2	GND	Ground
3	LED_0	Slider, LED 0 (Yellow)
4	LED_1	Slider, LED 1 (Yellow)
5	Y_S	Y-line for Slider
6	Y_W	Y-line for Wheel
7	LED_2	Slider, LED 2 (Yellow)
8	LED_3	Slider, LED 3 (Yellow)
9	Y_B	Y-line for Buttons
10	Not Connected	
11	Not Connected	
12	Not Connected	
13	Not Connected	
14	Not Connected	
15	LED_4	Slider, LED 4 (Yellow)
16	LED_5	Slider, LED 5 (Yellow)
17	LED_6	Slider, LED 6 (Yellow)
18	LED_7	Slider, LED 7 (Yellow)
19	GND	Ground
20	VCC	Target supply voltage

**Table 4-2. QT1 Xplained Pro MC Extension Header 2**

Pin on EXT	Function	Description
1	Not Connected	
2	GND	Ground
3	X_1	X-line 1 (for Slider and Wheel)
4	X_2	X-line 2 (for Slider and Wheel)
5	X_3	X-line 3 (for Button 1, Slider, and Wheel)
6	X_4	X-line 4 (for Button 2, Slider, and Wheel)
7	LED_8	Button 1, LED 8 (Yellow)
8	LED_9	Button 2, LED 9 (Yellow)
9	LED_R	Wheel, RGB LED (Red)
10	LED_G	Wheel, RGB LED (Green)
11	Not Connected	
12	Not Connected	

Pin on EXT	Function	Description
13	Not Connected	
14	Not Connected	
15	LED_B	Wheel, RGB LED (Blue)
16	Not Connected	
17	Not Connected	
18	Not Connected	
19	GND	Ground
20	VCC	Target supply voltage

#### 4.1.2 QT1 Xplained Pro SC Extension Headers

QT1 Xplained Pro SC implements two [Xplained Pro Standard Extension Header on page 6](#) marked with EXT1 and EXT2 in silkscreen. These headers makes it possible to connect the board to a Xplained Pro MCU board with a MCU featuring a PTC module. The pin-out definition for the extension headers can be seen in [Table 4-3, “QT1 Xplained Pro SC Extension Header 1” on page 9](#) and [Table 4-4, “QT1 Xplained Pro SC Extension Header 2” on page 9](#).

**Table 4-3. QT1 Xplained Pro SC Extension Header 1**

Pin on EXT	Function	Description
1	ID	Communication line to ID chip.
2	GND	Ground
3	Y_1	Y-line 1 for Slider
4	Y_2	Y-line 2 for Slider
5	Y_3	Y-line 3 for Slider
6	Y_4	Y-line 4 for Wheel
7	LED_0	Slider, LED 0 (Yellow)
8	LED_1	Slider, LED 1 (Yellow)
9	Y_5	Y-line 5 for Wheel
10	Y_6	Y-line 6 for Wheel
11	Not Connected	
12	Not Connected	
13	Not Connected	
14	Not Connected	
15	LED_2	Slider, LED 2 (Yellow)
16	Y_7	Y-line 7 for Button 2
17	LED_3	Slider, LED 3 (Yellow)
18	Y_8	Y-line 8 for Button 1
19	GND	Ground
20	VCC	Target supply voltage

**Table 4-4. QT1 Xplained Pro SC Extension Header 2**

Pin on EXT	Function	Description
1	Not Connected	
2	GND	Ground
3	LED_4	Slider, LED 4 (Yellow)
4	LED_5	Slider, LED 5 (Yellow)
5	LED_6	Slider, LED 6 (Yellow)
6	LED_7	Slider, LED 7 (Yellow)

Pin on EXT	Function	Description
7	LED_8	Button 1, LED 8 (Yellow)
8	LED_9	Button 2, LED 9 (Yellow)
9	LED_R	Wheel, RGB LED (Red)
10	LED_G	Wheel, RGB LED (Green)
11	Not Connected	
12	Not Connected	
13	Not Connected	
14	Not Connected	
15	LED_B	Wheel, RGB LED (Blue)
16	Not Connected	
17	Not Connected	
18	Not Connected	
19	GND	Ground
20	VCC	Target supply voltage

### 4.1.3 Peripherals

#### 4.1.3.1 LEDs

There are 13 (10 yellow and 1 RGB) LEDs available on each of the QT1 Xplained Pro extension boards that can be used to visualize the behavior of the touch sensors. Each sensor has its own set of LEDs. The slider has eight yellow LEDs, the buttons have one yellow LED each, and the wheel has a RGB LED. All LED's on the boards are active low, which means that the microcontroller needs to sink the corresponding IO lines to activate the LEDs.

#### 4.1.3.2 Touch Sensors

QT1 Xplained Pro have four touch sensors that can be used: One slider, one wheel, and two buttons. The sensor design on the Mutual Capacitance board and the Self Capacitance board are a bit different due to the method used for the touch sensing. For mutual capacitance, both X- and Y-lines from the microcontroller are used to sense the capacitance between the X and Y sensors. The sensors are placed on top of each other on the inner layers of the PCB. Self capacitance uses only Y-lines from the microcontroller and only one layer is used to place the sensor in the PCB. In this case, the self capacitance of the sensor is measured to calculate touch.

#### Note

This kit is only supported by Xplained Pro MCU boards that have a MCU with a built-in PTC and a matching pin out that connects all sensors of the extension. Currently supported MCU boards are *SAM D20 Xplained Pro* and *SAM D21 Xplained Pro*.

## 5. Hardware Revision History and Known Issues

### 5.1 Identifying Product ID and Revision

The revision and product identifier of Xplained Pro boards can be found in two ways, through Atmel Studio or by looking at the sticker on the bottom side of the PCB.

By connecting a Xplained Pro MCU board to a computer with Atmel Studio running, an information window will pop up. The first six digits of the serial number, which is listed under kit details, contain the product identifier and revision. Information about connected Xplained Pro extension boards will also appear in the Atmel Kits window.

The same information can be found on the sticker on the bottom side of the PCB. Most kits will print the identifier and revision in plain text as *A09-nnnn\rr* where *nnnn* is the identifier and *rr* is the revision. Boards with limited space have a sticker with only a QR-code which contains a serial number string.

The serial number string has the following format:

```
"nnnnrrssssssssss"  
n = product identifier  
r = revision  
s = serial number
```

The kit identifier for QT1 Xplained Pro is 2059 and 2061.

### 5.2 Revision 3

Revision 3 of QT1 Xplained Pro MC (2059) is the initial released version, there are no known issues.

Revision 3 of QT1 Xplained Pro SC (2061) is the initial released version, there are no known issues.

#### Known issues

- Read the user guide for the supported kits or the datasheet of the devices for any known issues regarding the peripheral touch controller.

## 6. Document Revision History

Document revision	Date	Comment
42193C	02/2014	Updated <a href="#">Table 4-2, “QT1 Xplained Pro MC Extension Header 2”</a> on page 8 and <a href="#">“Touch Sensors”</a> on page 10.
42193B	10/2013	Updated <a href="#">“Hardware Revision History and Known Issues”</a> on page 11.
42193A	10/2013	First release

## 7. Evaluation Board/Kit Important Notice

This evaluation board/kit is intended for use for **FURTHER ENGINEERING, DEVELOPMENT, DEMONSTRATION, OR EVALUATION PURPOSES ONLY**. It is not a finished product and may not (yet) comply with some or any technical or legal requirements that are applicable to finished products, including, without limitation, directives regarding electromagnetic compatibility, recycling (WEEE), FCC, CE or UL (except as may be otherwise noted on the board/kit). Atmel supplied this board/kit "AS IS," without any warranties, with all faults, at the buyer's and further users' sole risk. The user assumes all responsibility and liability for proper and safe handling of the goods. Further, the user indemnifies Atmel from all claims arising from the handling or use of the goods. Due to the open construction of the product, it is the user's responsibility to take any and all appropriate precautions with regard to electrostatic discharge and any other technical or legal concerns.

EXCEPT TO THE EXTENT OF THE INDEMNITY SET FORTH ABOVE, NEITHER USER NOR ATMEL SHALL BE LIABLE TO EACH OTHER FOR ANY INDIRECT, SPECIAL, INCIDENTAL, OR CONSEQUENTIAL DAMAGES.

No license is granted under any patent right or other intellectual property right of Atmel covering or relating to any machine, process, or combination in which such Atmel products or services might be or are used.



**Atmel Corporation** 1600 Technology Drive, San Jose, CA 95110 USA

**T:** (+1)(408) 441.0311

**F:** (+1)(408) 436.4200

| [www.atmel.com](http://www.atmel.com)

© 2014 Atmel Corporation. All rights reserved. / Rev.: 42193C-MCU-02/2014

Atmel<sup>®</sup>, Atmel logo and combinations thereof, Enabling Unlimited Possibilities<sup>®</sup>, AVR<sup>®</sup>, QTouch<sup>®</sup>, QT<sup>™</sup>, and others are registered trademarks or trademarks of Atmel Corporation or its subsidiaries. ARM<sup>®</sup> and others are registered trademarks of ARM Ltd. Other terms and product names may be trademarks of others.

Disclaimer: The information in this document is provided in connection with Atmel products. No license, express or implied, by estoppel or otherwise, to any intellectual property right is granted by this document or in connection with the sale of Atmel products. EXCEPT AS SET FORTH IN THE ATMEL TERMS AND CONDITIONS OF SALES LOCATED ON THE ATMEL WEBSITE, ATMEL ASSUMES NO LIABILITY WHATSOEVER AND DISCLAIMS ANY EXPRESS, IMPLIED OR STATUTORY WARRANTY RELATING TO ITS PRODUCTS INCLUDING, BUT NOT LIMITED TO, THE IMPLIED WARRANTY OF MERCHANTABILITY, FITNESS FOR A PARTICULAR PURPOSE, OR NON-INFRINGEMENT. IN NO EVENT SHALL ATMEL BE LIABLE FOR ANY DIRECT, INDIRECT, CONSEQUENTIAL, PUNITIVE, SPECIAL OR INCIDENTAL DAMAGES (INCLUDING, WITHOUT LIMITATION, DAMAGES FOR LOSS AND PROFITS, BUSINESS INTERRUPTION, OR LOSS OF INFORMATION) ARISING OUT OF THE USE OR INABILITY TO USE THIS DOCUMENT, EVEN IF ATMEL HAS BEEN ADVISED OF THE POSSIBILITY OF SUCH DAMAGES. Atmel makes no representations or warranties with respect to the accuracy or completeness of the contents of this document and reserves the right to make changes to specifications and products descriptions at any time without notice. Atmel does not make any commitment to update the information contained herein. Unless specifically provided otherwise, Atmel products are not suitable for, and shall not be used in, automotive applications. Atmel products are not intended, authorized, or warranted for use as components in applications intended to support or sustain life.

# AMEYA360

## Components Supply Platform

### Authorized Distribution Brand :



### Website :

Welcome to visit [www.ameya360.com](http://www.ameya360.com)

### Contact Us :

#### ➤ Address :

401 Building No.5, JiuGe Business Center, Lane 2301, Yishan Rd  
Minhang District, Shanghai , China

#### ➤ Sales :

Direct +86 (21) 6401-6692

Email [amall@ameya360.com](mailto:amall@ameya360.com)

QQ 800077892

Skype [ameyasales1](#) [ameyasales2](#)

#### ➤ Customer Service :

Email [service@ameya360.com](mailto:service@ameya360.com)

#### ➤ Partnership :

Tel +86 (21) 64016692-8333

Email [mkt@ameya360.com](mailto:mkt@ameya360.com)