

VOLTAGE AND CURRENT STEPDOWN PWM CONTROLLER

- OUTPUT HIGH SIDE CURRENT SENSING
- PRECISE CC/CV REGULATION
- ADJUSTABLE SWITCHING FREQUENCY
- ADJUSTABLE OVP/UVLP UVLO THRESHOLDS
- STANDBY MODE FEATURE
- SUSTAINS 60V
- MINIMAL EXTERNAL COMPONENTS COUNT
- DRIVES EXTERNAL P-CHANNEL MOSFET OR PNP BIPOLAR TRANSISTORS

DESCRIPTION

TSM108 is a step-down PWM controller designed to drive an external P-channel MOSFET, providing constant voltage and constant current regulations in battery charger applications.

TSM108 can easily be configured for very wide voltage and current needs.

It has been realized in rugged BCD technology and includes a PWM generator, Voltage and Current control loops, a precise Voltage Reference, and a Gate Driver. The device can sustain 60V on Vcc, and therefore meet the standard Load Dump requirements of the 12V cars battery.

On boards there are other security functions which lock the external power in OFF state: OVLO (Over Voltage Lockout) and UVLO (Under Voltage Lockout). The mosfet gate is also protected from over voltage drive thanks to a 12V clamping protection circuit.

Moreover, a standby feature allows very low quiescent current when activated, but keeping safe the external power element when Off.

The IC is suitable for 12V car accessories, as well as other DC/DC step down converters.

APPLICATION DIAGRAM

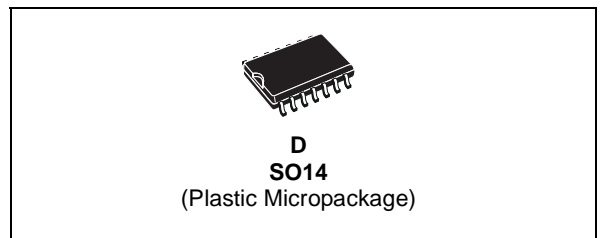
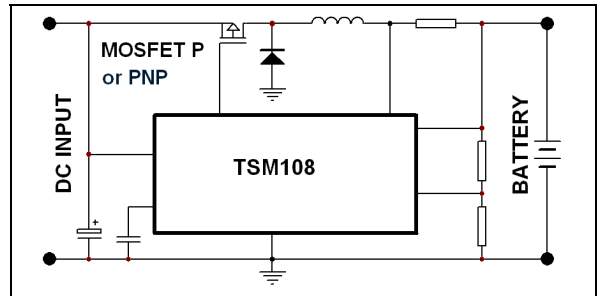

ORDER CODE

| Part Number | Temperature Range | Package |
|-------------|-------------------|---------|
| | | D |
| TSM108I | -40°, +125°C | • |

D = Small Outline Package (SO) - also available in Tape & Reel (DT)

PIN CONNECTIONS (top view)

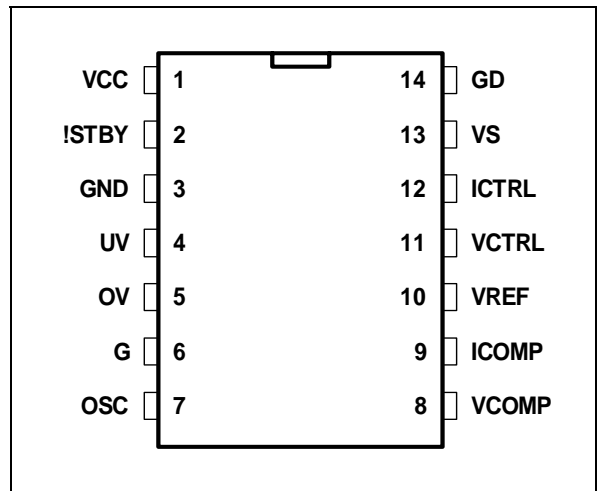

PIN DESCRIPTION

| Name | Pin | Description |
|-------|-----|---|
| VCC | 1 | Supply voltage of both the signal part and the gate drive |
| !STBY | 2 | Standby Command; when Low, the device goes in standby |
| GND | 3 | Ground. Current return for both the gate drive and quiescent currents |
| UV | 4 | Programmable Under Voltage Lockout. Preset value is 8V min |
| OV | 5 | Programmable Over Voltage Lockout. Preset value is 33V max |
| G | 6 | Internally Connected to Ground |
| OSC | 7 | Oscillator pin to set operating frequency via external capacitor |
| VCOMP | 8 | Error amplifier output of voltage loop |
| ICOMP | 9 | Error amplifier output of current loop |
| VREF | 10 | 2,52V Voltage Reference |
| VCTRL | 11 | Error amplifier of voltage loop, non inverting |
| ICTRL | 12 | Error amplifier of current loop inverting input |
| VS | 13 | Current sense Input |
| GD | 14 | Totem pole gate driver for external P-channel MOSFET |

ABSOLUTE MAXIMUM RATINGS

| Symbol | Parameter | Value | Unit |
|------------|---|-------------|------|
| V_{CC} | Supply Voltage - Transient conditions (400ms max.) | 60 | V |
| T_j | Maximum Junction Temperature | 150 | °C |
| R_{thja} | Thermal Resistance Junction to Ambient (SO package) | 130 | °C/W |
| T_{stg} | Storage Temperature | -55 to +125 | °C |
| V_{max} | Out Terminal Voltage (ICTRL, VS) | 10 | V |

OPERATING CONDITIONS

| Symbol | Parameter | Value | Unit |
|------------|------------------------------------|--------------|------|
| V_{CC} | Supply Voltage | UVLO to OVLO | V |
| V_{ter1} | Out Terminal Voltage (ICTRL, VS) | 0 to 9 | V |
| V_{ter2} | Out Terminal Voltage (UV, OV, OSC) | 0 to 6 | V |

ELECTRICAL CHARACTERISTICS

$T_{amb} = 25^{\circ}\text{C}$, $V_{CC} + 12\text{V}$ (unless otherwise specified)

| Symbol | Parameter | Test Condition | Min. | Typ. | Max. | Unit |
|--|--|--|------------|-------|------------|---------------|
| CURRENT CONSUMPTION | | | | | | |
| I_{CC} | Current Consumption | | | 4 | 7 | mA |
| STANDBY | | | | | | |
| I_{stby} | Current Consumption in Standby Mode | | | 150 | | μA |
| V_{sh} | Input Standby Voltage High Impedance | Internal Pull up resistor. Stby pin should be left open | 2 | | | V |
| V_{sl} | Input Standby Voltage Low | | | | 0.8 | V |
| OSCILLATOR | | | | | | |
| F_{OSC} | Frequency of the Oscillator | $C_{OSC} = 220\text{pF}$ | 70 | 100 | 130 | kHz |
| VOLTAGE CONTROL ^{1) 2)} | | | | | | |
| V_{ref} | Voltage Control Reference | $T_{amb} = 25^{\circ}\text{C}$ $-25^{\circ}\text{C} < T_{amb} < 85^{\circ}\text{C}$ | 2.450 | 2.520 | 2.590 | V |
| CURRENT CONTROL ^{3) 4) 5)} | | | | | | |
| V_{sense} | Current Control Reference Voltage | $T_{amb} = 25^{\circ}\text{C}$ $-25^{\circ}\text{C} < T_{amb} < 85^{\circ}\text{C}$ | 196 191 | 206 | 216 221 | mV |
| GATE DRIVE - P CHANNEL MOSFET DRIVE | | | | | | |
| I_{sink} | Sink Current - Switch ON | $T_{amb} = 25^{\circ}\text{C}$ $-25^{\circ}\text{C} < T_{amb} < 85^{\circ}\text{C}$ | 15 | 40 | | mA |
| I_{source} | Source Current - Switch OFF | $T_{amb} = 25^{\circ}\text{C}$ $-25^{\circ}\text{C} < T_{amb} < 85^{\circ}\text{C}$ | 30 | 80 | | mA |
| C_{load} | Input Capacitance of the PMOSFET ⁶⁾ | | | 1 | 1.5 | nF |
| PWM | | | | | | |
| $\Delta_{max.}$ | Maximum Duty Cycle of the PWM function | | | 95 | 100 | % |
| UVLO | | | | | | |
| UV | Under Voltage Lock Out ⁷⁾ | $-25^{\circ}\text{C} < T_{amb} < 85^{\circ}\text{C}$ | 8 | | 9 | V |
| UV_{hyst} | UVLO Voltage Hysteresis - low to high | | | 200 | | mV |
| R_{Uvl} | Upper Resistor of UVLO bridge ⁸⁾ | $T_{amb} = 25^{\circ}\text{C}$ | | 184 | | k Ω |
| R_{Uvl} | Lower Resistor of UVLO bridge (see note 8) | $T_{amb} = 25^{\circ}\text{C}$ | | 76.5 | | k Ω |
| OVLO | | | | | | |
| OV | Over Voltage Lock Out (see note 7) | $-25^{\circ}\text{C} < T_{amb} < 85^{\circ}\text{C}$ | 32 | | 35 | V |
| OV_{hyst} | OVLO Voltage Hysteresis - low to high | | | 400 | | mV |
| R_{Ovl} | Upper Resistor of OVLO bridge (see note 8) | $T_{amb} = 25^{\circ}\text{C}$ | | 275 | | k Ω |
| R_{Ovl} | Lower Resistor of OVLO bridge (see note 8) | $T_{amb} = 25^{\circ}\text{C}$ | | 23.2 | | k Ω |

1. V_{ref} parameter indicates global precision of the voltage control loop.

2. Control Gain : $A_v = 95\text{dB}$; Input Resistance : $R_{in} = \text{infinite}$; Output Resistance : $R_{out} = 700\text{M}\Omega$; Output Source/Sink Current : $I_{so}, I_{si} = 150\mu\text{A}$; Recommended values for the compensation network are : 22nF & $22\text{k}\Omega$ in series between output and ground.

3. V_{sense} parameter indicated global precision of the current control loop.

4. Control Gain : $A_v = 105\text{dB}$; Input Resistance : $R_{in} = 380\text{k}\Omega$; Output Resistance : $R_{out} = 105\text{M}\Omega$; Output Source/Sink Current : $I_{so}, I_{si} = 150\mu\text{A}$; Recommended values for the compensation network are : 22nF & $22\text{k}\Omega$ in series between output and ground.

5. A current foldback function is implemented thanks to a systematic -6mV negative offset on the current amplifier inputs which protects the battery from over charging current under low battery voltage conditions, or output short circuit conditions.

6. The Gate Drive output stage has been optimized for PMosfets with input capacitance equal to C_{load} . A bigger Mosfet (with input capacitance higher than C_{load}) can be used with TSM108, but the gate drive performances will be reduced (in particular when reaching the D_{max} . PWM mode).

7. The given limits comprise the hysteresis (UV_{hyst}).

8. It is possible to modify the UVLO and OVLO limits by adding a resistor (to ground or to V_{CC}) on the pins UV and OV. The internal values of the resistor should be taken into account.

DETAILED INTERNAL SCHEMATIC

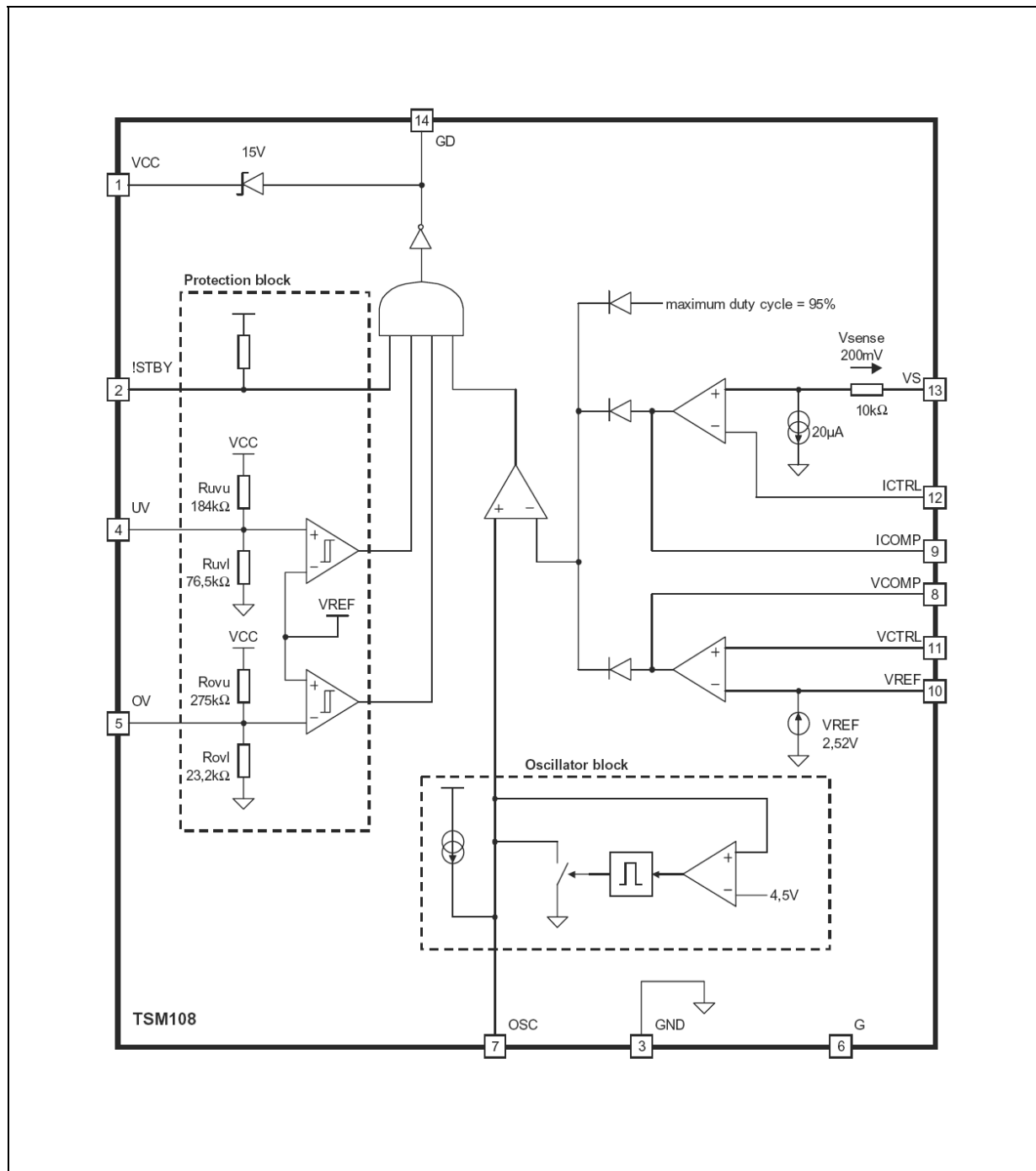

OSCILLATOR FREQUENCY VERSUS TIMING CAPACITOR

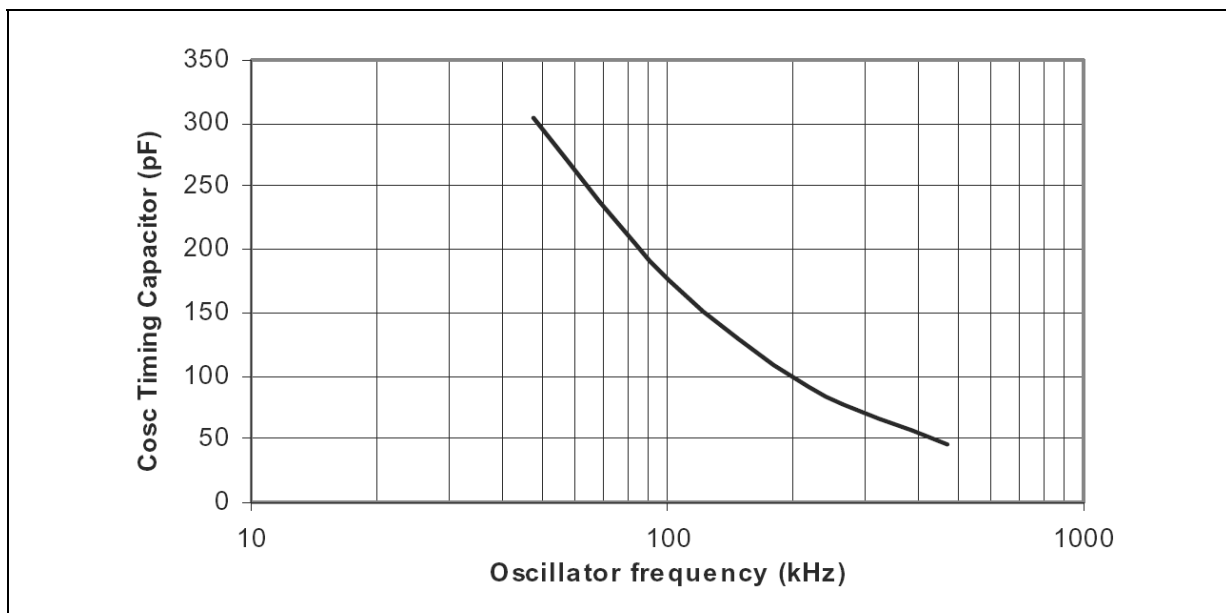

TSM108 AS A STAND ALONE DC/DC CONVERTER FOR CIGARETTE LIGHTER ACCESSORIES

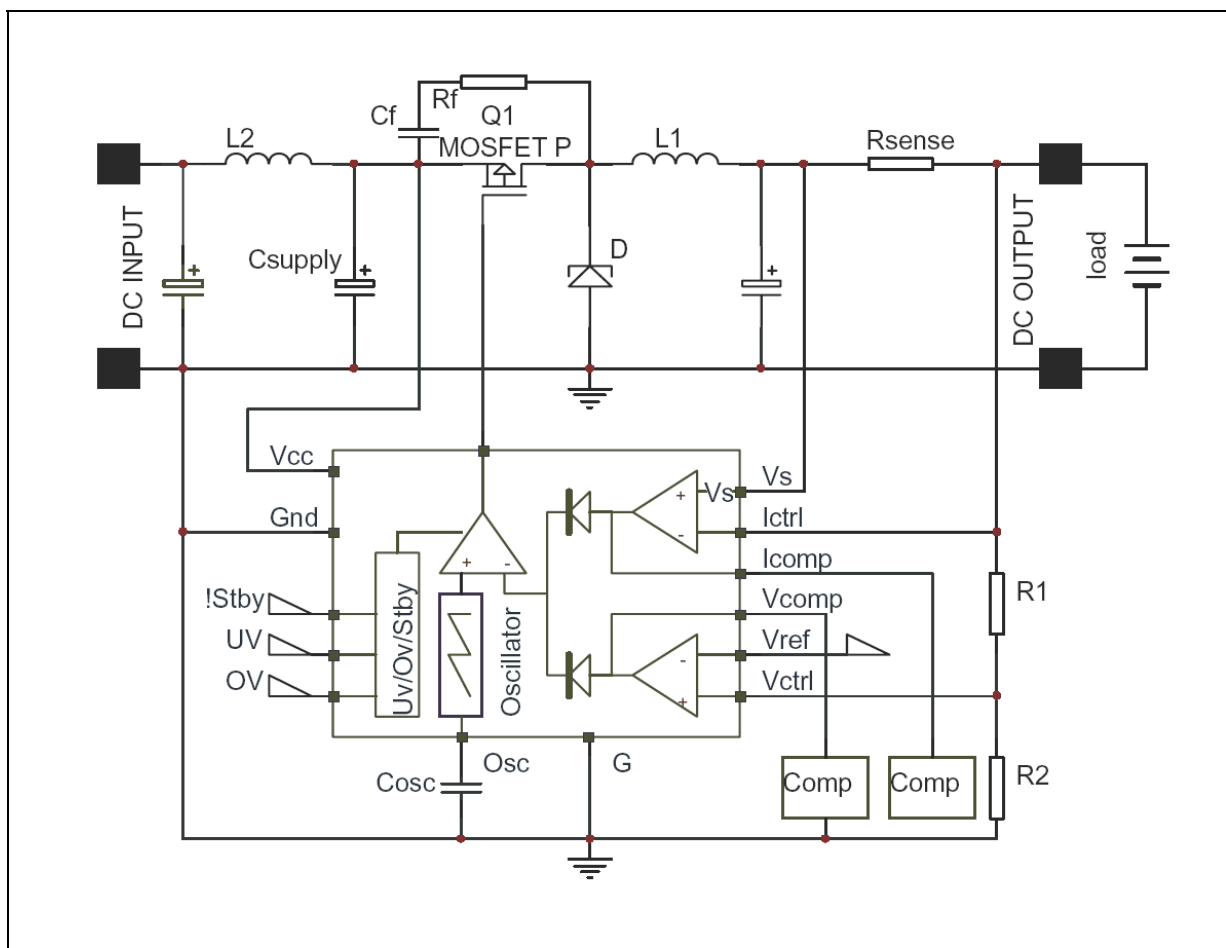

PRINCIPLE OF OPERATION AND APPLICATION HINTS

Description of a DC/DC step down battery charger

1. Voltage and Current Controller

The device has been designed to drive an external P-Channel MOSFET in PWM mode and in Step Down topology. Its two integrated operational amplifiers ensure accurate Voltage and Current Regulation loops.

The Voltage Control dedicated operational amplifier acts as an error amplifier and compares a part of the output voltage (external voltage divider) to an integrated highly precise voltage reference (V_{ref}).

The Current Control dedicated operational amplifier acts as an error amplifier and compares the drop voltage through the sense resistor to an integrated low value voltage reference (V_s).

These two amplified errors are ORed through diodes, and the resulting signal ("max of") is a reference for the PWM generator to set the switching duty cycle of the P-Channel MOSFET transistor.

The PWM generator comprises an oscillator (saw tooth) and a comparator which gives a variable duty cycle from 0 to 95%. This PWM signal is the direct command of the output totem pole stage to drive the Gate of the P-Channel MOSFET.

Thanks to this architecture, the TSM108 is ideal to be used from a DC power supply to control the charging Voltage and Current of a battery in applications such as accessories for cellular phones chargers and post-regulation in power supplies.

2. Voltage Control

The Voltage Control loop can be set by an external voltage divider connected between the output positive line and the Ground reference. The middle point has to be connected to the V_{ctrl} pin of TSM108, and, if R1 is the upper resistor, and R2, the lower resistor of the voltage divider, the values of R1 and R2 are:

$$\square \text{ eq1: } V_{ref} = V_{out} \times R2 / (R1 + R2)$$

In Constant Voltage Control mode, the output voltage is fixed by the R1/R2 resistor.

The total value of R1 + R2 voltage divider will determine the necessary bleeding current to keep the Voltage Control loop effective, even under "no load" conditions.

The current compensation loop is directly accessible from the pins Vcomp and Vref. The compensation network is highly dependant of the operating conditions (switching frequency, external components R, L, C, MOSFET, output capacitor, etc...).

3. Current Control

The Current control loop can be set by the sense resistor that has to be placed in series on the output positive line. The output side of the Sense resistor has to be to Ictrl pin, and the common point between Rsense and the choke has to be connected to the Vs pin. If Ilim is the value of the charging current limit. The value of Rsense should verify:

$$\square \text{ eq2: } V_s = R_{sense} \times I_{lim}$$

In Constant Current Control mode, the output current is fixed by the Rsense resistor (under output short circuit conditions, please refer to this corresponding section).

The wattage calibration (W) of the sense resistor should be chosen according to:

$$\square \text{ eq2a: } W > R_{sense} \times I_{lim}^2$$

The current compensation loop is directly accessible from Icomp and Ictrl pin.

The compensation network is highly dependant on the operating conditions.

4. PWM frequency

The internal oscillator frequency is a saw tooth waveform that can be adjusted. In accessories like battery chargers, it is suggested to set the switching frequency at a typical 100kHz in order to obtain a good compromise between the ripple current and the choke size. An external capacitor connected between Osc pin and ground set the switching frequency.

The maximum duty cycle of the PWM function is limited to 95% in order to ensure safe driving of the MOSFET.

5. Gate Drive

The Gate Drive stage is directly commanded from the PWM output signal. The Gate Drive stage is a totem pole Mosfet stage which bears different On resistances in order to ensure a slower turn ON than turn OFF of the P-Channel MOSFET. The values of the output Gate Drive currents are given by I_{sink} (switch ON) and I_{source} (switch OFF).

The Gate Drive stage bears an integrated voltage clamp which will prevent the P-Channel MOSFET gate to be driven with voltages higher than 15V (acting like a zener diode between V_{cc} and GD (Gate Drive) pin).

6. Under Voltage Lock-Out, Over Voltage Lock-Out

The UVLO and OVLO security functions aim at the global application security.

When the Power supply decreases, there is the inherent risk to drive the P-Channel MOSFET with insufficient Gate voltage, and therefore to lead the MOSFET to linear operation, and to its destruction.

The UVLO is an input power supply voltage detection which imposes a complete switch OFF of the P-Channel MOSFET as soon as the Power Supply decreases below UV. To avoid unwanted oscillation of the MOSFET, a fixed hysteresis margin is integrated (UVhyst).

UVLO is internally programmed to ensure 8V min and 9V max, but thresholds can be adjusted by adding an external voltage divider to modify the value. The resistors typical values are given (R_{uvh} , R_{uvl}).

The OVLO is fixing the supply voltage at which the device (and the external power section) is switched OFF.

OVLO is internally programmed to ensure 32V min. and 33V max., but it can be adjusted with an external voltage divider.

Examples:

Let's suppose that the internally set value of the UVLO and / or OVLO level should be modified in a specific application, or under specific requirements.

6.1. UVLO decrease:

If the UVLO level needs to be lowered (UV1), an additional resistor (R_{uvh1}) must be connected between UV and V_{cc} following the equation:

$$\begin{aligned} \square \quad UV &= V_{ref} (R_{uvh}/R_{uvl} + 1) \\ \square \quad UV1 &= V_{ref} ((R_{uvh}/R_{uvh1})/R_{uvl} + 1) \quad (i) \end{aligned}$$

where R_{uvh}/R_{uvh1} means that R_{uvh1} is in parallel to R_{uvh}

Solving i. we obtain:

$$\square \quad R_{uvh1} = R_{uvl} \times R_{uvh} (UV1 - V_{ref}) / (V_{ref} \times R_{uvh} - R_{uvl} (UV1 - V_{ref}))$$

As an example, if UV1 needs to be set to 6V, $R_{uvh1} = 256k\Omega$

6.2. UVLO increase:

If the UVLO level needs to be increased (UV2), an additional resistor (R_{uvl2}) must be connected between UV and Gnd following the equation.

$$\begin{aligned} \square \quad UV &= V_{ref} (R_{uvh}/R_{uvl} + 1) \\ \square \quad UV1 &= V_{ref} (R_{uvh}/(R_{uvl}/R_{uvl2}) + 1) \quad (ii) \end{aligned}$$

where R_{uvl}/R_{uvl2} means that R_{uvl2} is in parallel to R_{uvl}

Solving ii. we obtain:

$$\square \quad R_{uvl2} = V_{ref} \times R_{uvh} R_{uvl} / (UV2 \times R_{uvl} - V_{ref} \times (R_{uvh} + R_{uvl}))$$

As an example, if UV2 needs to be set to 12V, $R_{uvl2} = 132k\Omega$

6.3. OVLO decrease:

If the OVLO level needs to be lowered (OV1), an additional resistor (R_{ovh1}) must be connected between OV and V_{cc} following the equation:

$$\begin{aligned} \square \quad OV &= V_{ref} (R_{ovh}/R_{ovl} + 1) \\ \square \quad OV1 &= V_{ref} ((R_{ovh}/R_{ovh1})/R_{ovl} + 1) \quad (iii) \end{aligned}$$

where R_{ovh}/R_{ovh1} means that R_{ovh1} is in parallel to R_{ovh}

Solving iii. we obtain:

$$\square \quad R_{ovh1} = R_{ovl} \times R_{ovh} (OV1 - V_{ref}) / (V_{ref} \times R_{ovh} - R_{ovl} (OV1 - V_{ref}))$$

As an example, if OV1 needs to be set to 25V, $R_{ovh1} = 867k\Omega$

6.4. OVLO increase:

If the OVLO level needs to be increased (OV2), an additional resistor (R_{ovl2}) must be connected between OV and Gnd following the equation.

$$\begin{aligned} \square \quad OV &= V_{ref} (R_{ovh}/R_{ovl} + 1) \\ \square \quad OV2 &= V_{ref} (R_{ovh}/(R_{ovl}/R_{ovl2}) + 1) \quad (iv) \end{aligned}$$

where R_{ovl}/R_{ovl2} means that R_{ovl2} is in parallel to R_{ovl}

Solving iv. we obtain:

$$\square \quad R_{ovl2} = V_{ref} \times R_{ovh} R_{ovl} / (OV2 \times R_{ovl} - V_{ref} \times (R_{ovh} + R_{ovl}))$$

As an example, if OV2 needs to be set to 40V, $R_{ovl2} = 87k\Omega$

7. Standby Mode

In order to reduce to a minimum the current consumption of the TSM108 when in inactive phase, the Standby mode (!Stby pin of TSM108) imposes a complete OFF state of the P-Channel MOSFET, as well as a complete shut off of the main functions of the TSM108 (operational amplifier, PWM generator and oscillator, UVLO and OVLO) and therefore reduces the consumption of the device. The !STBY command is TTL compatible.

8. Power Transistor: P-channel MOSFET or PNP Transistor?

The TSM108 can drive, with minor external components change, either a P-channel MOSFET, or a PNP transistor. The user can choose the type of external power element, nevertheless, here follows a few considerations which will help to take this decision

The following figures shows two different schematics where both driving abilities of TSM108 are shown. The third schematic shows how to improve the switch off commutation when using a bipolar PNP transistor.

P-channel MOSFET

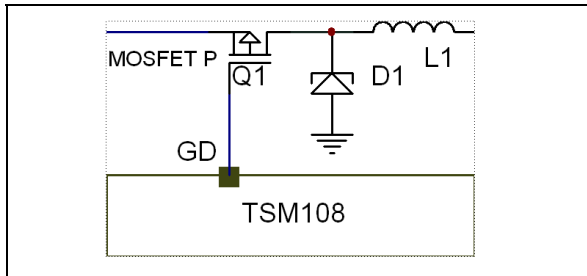

PNP transistor

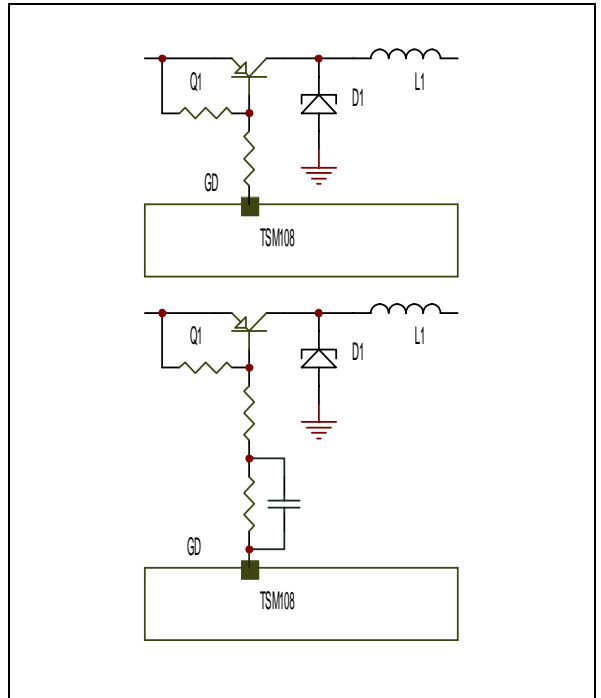

The most immediate way to choose between a P-channel MOSFET or a PNP transistor is to consider the ratio between the output power of the application and the expected components price: the lower the power, the more suitable the PNP transistor is; the higher the power, the more suitable the P-channel MOSFET is. As an example, for a DC/DC adaptor built for 12V/6V, the recommended limit to choose between P-channel Mosfet and PNP transistor is around 200mA.

Below 200mA, the price/performance ratio of the PNP transistor is very attractive, whereas above 200mA, the P-channel Mosfet takes the advantage.

9. Calculation of the Passive Elements

- Let's consider the following characteristics for a Cigarette Lighter Cellular Phone Battery Charger:
- $V_{in} = 12V$ - input voltage of the converter
- $V_{out} = 6V$ - output voltage of the converter
- $F = 100kHz$ - switching frequency of the converter adjustable with an external capacitor
- $I_{out} = 625mA$ - output current limitation

9.1. Inductor

The minimum inductor value to choose should apply to

$$L_{min} = (1 - D) R / 2F$$

where $R = V_{out} / I_{out} = 9.6W$

and where $D = V_{out} / V_{in} = 0.5$

Therefore, $L_{min} = 24\mu H$.

The frequency may vary depending on the temperature, due to the fact that the frequency is fixed by an external capacitor. Therefore, we must calculate the inductor value considering the worst case condition in order to avoid the saturation of the inductor, which is when the battery voltage is at its highest, and the switching frequency at its lowest. Thanks to the OVLO onboard function, the operation of the DC/DC converter will be stopped as soon as the voltage exceeds the OVLO level. Let's suppose the OVLO pin has been left open, therefore, the maximum input voltage of the DC/DC converter will be $V_{in\ max.} = 32V$. Frequency min stands in the range of 75kHz

In this case, $D = 6 / 32 = 0.1875$, therefore $L_{min} = 52\mu H$.

If we allow a 25% security margin

$$L_{min} = 68\mu H$$

9.2. Capacitor

The capacitor choice will depend mainly on the accepted voltage ripple on the output

$$\text{Ripple} = DV_{out} / V_{out} = (1-D) / 8LCF^2$$

Therefore, $C = (1-D) / 8LRippleF^2$. If $C = 22\mu F$, then $\text{Ripple} = 0.4\%$ which should be far acceptable.

Here again, the worst conditions for the ripple are set when the input voltage is at the highest (32V) and the frequency at its lowest (75kHz).

with $C = 22\mu F$, $\text{Ripple} = 1.2\%$

9.3. Ratings for the Inductor, Capacitor, Transistor and Diode

The inductor wire must be rated at the rms current, and the core should not saturate for peak inductor current. The capacitor must be selected to limit the output ripple to the design specifications, to withstand peak output voltage, and to carry the required rms current.

The transistor and the diode should be rated for the maximum input voltage (up to 60V). The recirculation diode has to be a Schottky type for efficiency maximization or ultrafast recovery.

A compromise between the switching and conduction losses of the external power element has to be found.

Losses in the switch are:

$$P_{switch} = P_{rise} + P_{fall} + P_{on}$$

where $P_{rise} + P_{fall}$ represent the switching losses and where P_{on} represents the conduction losses.

$$P_{rise} + P_{fall} = I_{out} \times V_{in} \times (T_{rise} + T_{fall}) \times F / 2$$

$$P_{on} = R_{on} \times I_{out}^2 \times d$$

where T_{rise} is the switching on time, and T_{fall} is the switching off time, and where d is the duty cycle of the switching profile, which can be approximated to 1 under full load conditions.

With the two last equations, we can see easily that what we may gain by choosing a performing low R_{dson} Pchannel MOSFET (for example) may be jeopardised by the long on and off switching times required when using a large input gate capacitance.

10. Electromagnetic Compatibility

The small schematic hereafter shows how to reduce the EMC noise when used in an EMC sensitive environment:

EMC Improvement

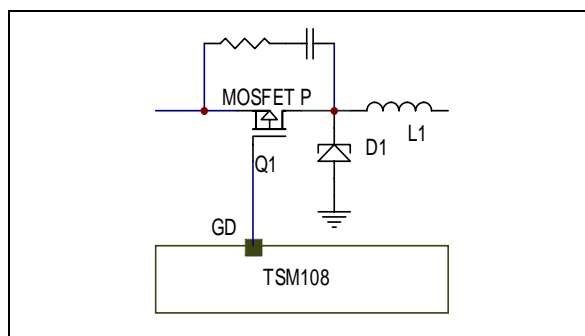

The RC components should realise a time constant corresponding to one tenth of the switching time constant of the TSM108 (i.e. in our example, the oscillator frequency is set to 10μs corresponding to 100kHz, therefore, the RC couple should realise a time constant close to 1μs).

Choosing the components must privilege a rather small resistivity (between 10 to 100W). A guess couple of values for RC in our example would be: $R = 22W$, $C = 47nF$

11. Efficiency Calculations (rough estimation)

The following gives a rough estimation of the efficiency of a car phone charger, knowing that the exact calculations depend on a lot of parameters, as well as on a wide choice of external components.

Let's consider the following characteristics of a classical car phone charger application:

$$\square \quad V_{in} = V_{cc} = 12V, I_{out} = 625mA, V_{out} = 6V$$

- ❑ Mosfet: Pchannel Mosfet: $R_{dson} = 100m\Omega$, $C_{iss} = 1nF$.
- ❑ Driver: TSM108
- ❑ PWM frequency: 100kHz
- ❑ Free wheel diode: $V_f = 0.7V$
- ❑ Shunt: $R_{sense} = 330m\Omega$

The efficiency (η) of a regulator is defined as the ratio of the charging power (P_{out}) to the total power from the supply (P_{in}).

❑ Eq3: $\eta = P_{out}/P_{in}$

The output power is:

$P_{out} = I_{out} \times V_{out}$ where I_{out} is the charging current ($V_{sense}/R_{sense} = 625mA$ at full load) and V_{out} is the regulated voltage ($V_{ref}(1+R1/R2) = 6V$).

$P_{out} = 3.75W$

The input power can be found by adding the output power (P_{out}) to the total power loss in the circuit (P_{losses}) i.e.

❑ $P_{in} = P_{out} + P_{losses}$

The power is lost partly on the chip and partly on the external components which are mainly the diode, the switch and the shunt. $P_{losses} = P_{chip} + P_{switch} + P_{diode} + P_{shunt}$.

In P_{losses} , we neglect the losses in the inductor (because the current through the inductor is smoothed making the serial resistor of the inductor very low), and the losses in the Gate (charge and discharge).

a. The power lost in the chip is $P_{chip} = V_{cc} \times I_{cc}$. ($V_{cc} = 12V$, $I_{cc} = 6mA$) $P_{chip} = 72mW$

b. The power lost in the switch depends on the ON resistance of the switch and the current passing through it. Also there is power loss in the switch during switching time (commutation losses) and that depends on the switching frequency and the rise and fall time of the switching signal.

Rise time (Pchannel goes off) depends on the output source current of the TSM108 and the input gate capacitance of the Mosfet.

$Trise = C_{iss} \times V_{gate} / I_{source}$

Fall time (Pchannel goes on) depends on the output sink current of the TSM108 and the input gate capacitance of the Mosfet .

$Tfall = C_{iss} \times V_{gate} / I_{sink}$

$Trise = 150ns$ and $Tfall = 300ns$ (V_{gate} is approx 12V).

❑ $P_{switch} = P_{rise} + P_{fall} + P_{on}$

where:

$P_{rise} = I_{out} \times (V_{cc} + V_f) \times Trise \times PWMfreq / 2$

$P_{rise} = 625mA \times 12.7 \times 150ns \times 100kHz / 2$

$P_{rise} = 59.5mW$

where:

$P_{fall} = I_{out} \times (V_{cc} + V_f) \times Tfall \times PWMfreq / 2$

$P_{fall} = 625mA \times 12.7 \times 300ns \times 100kHz / 2$

$P_{fall} = 119.1mW$

where:

$P_{on} = R_{dson} \times I_{out}^2 \times D$ (where D is the duty cycle - at full charge, D can be approximated to 1)

$P_{on} = 100m\Omega \times 625mA^2$. $P_{on} = 39.1mW$

❑ $P_{switch} = 217.7mW$

c. The power lost in the fly back diode is $P_{diode} = V_f \times I_{out}(1-D)$ where $D = V_{out}/V_{cc} = 6/12$. $D = 0.5$

❑ $P_{diode} = 219mW$

d. the power lost in the sense resistor (shunt resistor) is $P_{shunt} = R_{sense} \times I_{out}^2$

❑ $P_{shunt} = 129mW$

Therefore,

$P_{losses} = P_{chip} + P_{switch} + P_{diode} + P_{shunt}$

$= 72mW + 217.7mW + 219mW + 129mW$

❑ $P_{losses} = 638mW$

The yield (efficiency) is

❑ $P_{out} / P_{in} = 3.75 / (3.75 + 0.638) = 85.5\%$

$\eta = 85.5\%$

The following table gives a tentative yield improvement view following the choice of some external components. Be aware that some of the following choices have non negligible cost effects on the total application.

Improved yield - by changing the external components value one by one

| | | | | | | |
|-------------------|--------|-------|-------|--------|-------|-------|
| R_{sense} | 330mΩ | 220mΩ | - | - | - | - |
| I_{out} | 625mA | 936mA | - | - | - | - |
| $V_{out} (R1/R2)$ | 6V | - | 7.5V | - | - | - |
| R_{dson} | 100mΩ | - | - | 140mΩ | - | - |
| C_{iss} | 0nF | - | - | 0.85nF | - | - |
| PWM Freq | 100kHz | - | - | - | 50kHz | - |
| Free Wheel | 0.7V | - | - | - | - | 0.3V |
| Yield | 85.5% | 85.6% | 88.9% | 85.7% | 87.3% | 88.1% |
| Cost influence | - | = | = | < | > | >> |



12. Measured Performances

The few following curves show the measured performances of TSM108 used in DC/DC step down

converter, either with a Pchannel MOSFET or with a PNP bipolar transistor.

12.1. Voltage and Current Control, Efficiency Performances using a Pchannel MOSFET:

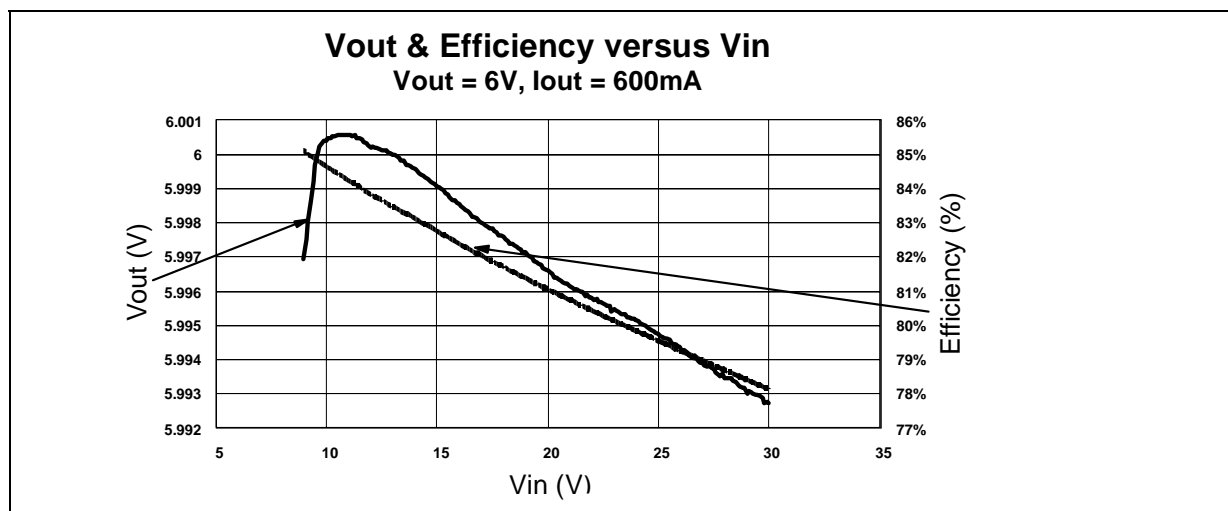
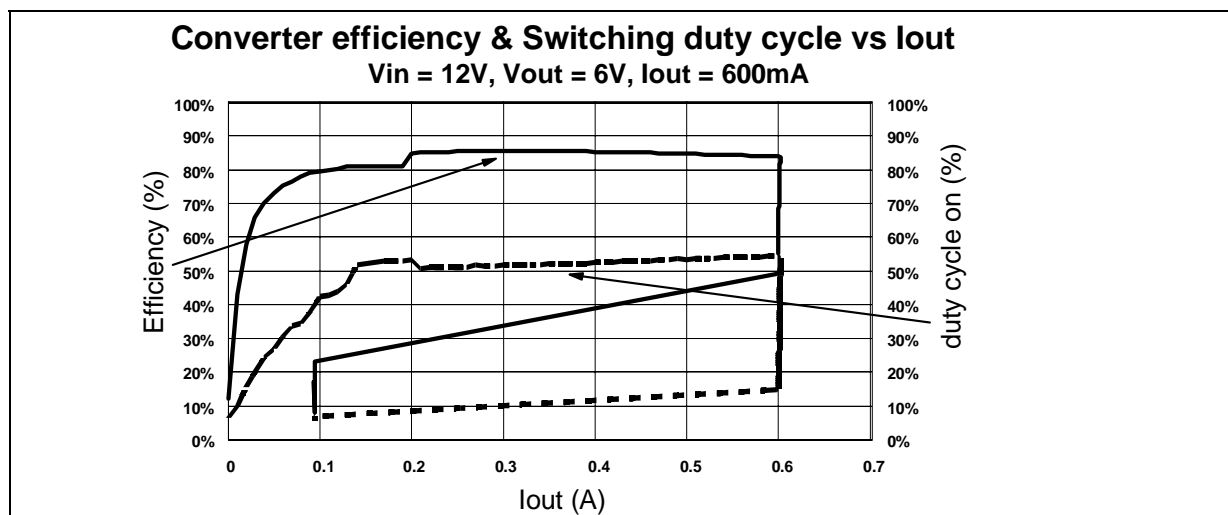
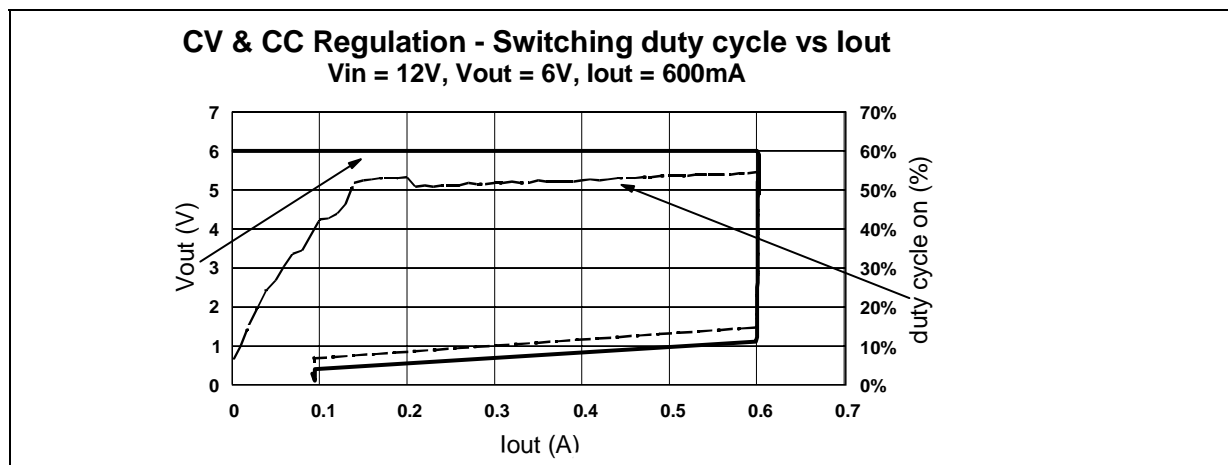

12.2. Voltage and Current Control, Efficiency Performances using a PNP bipolar transistor

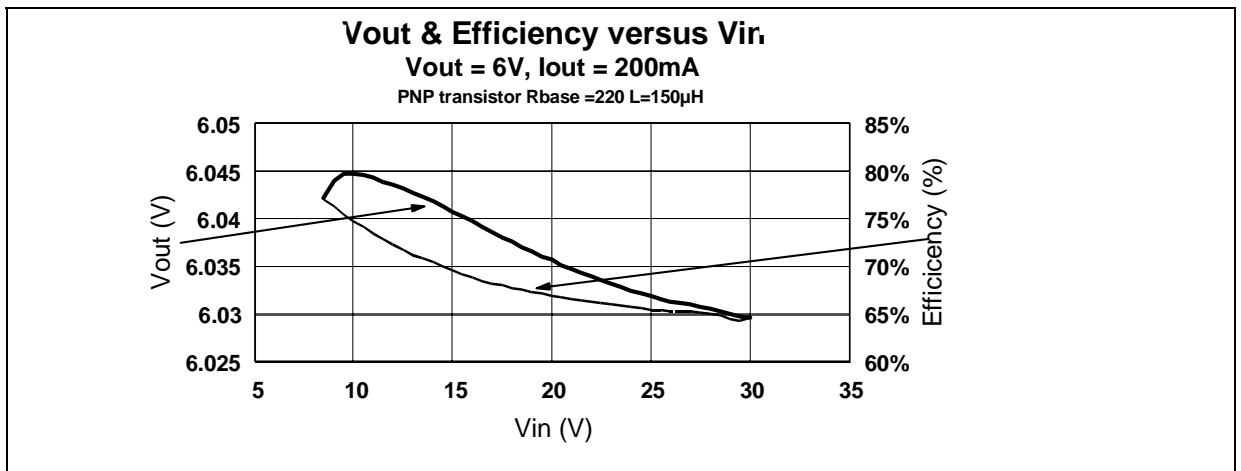
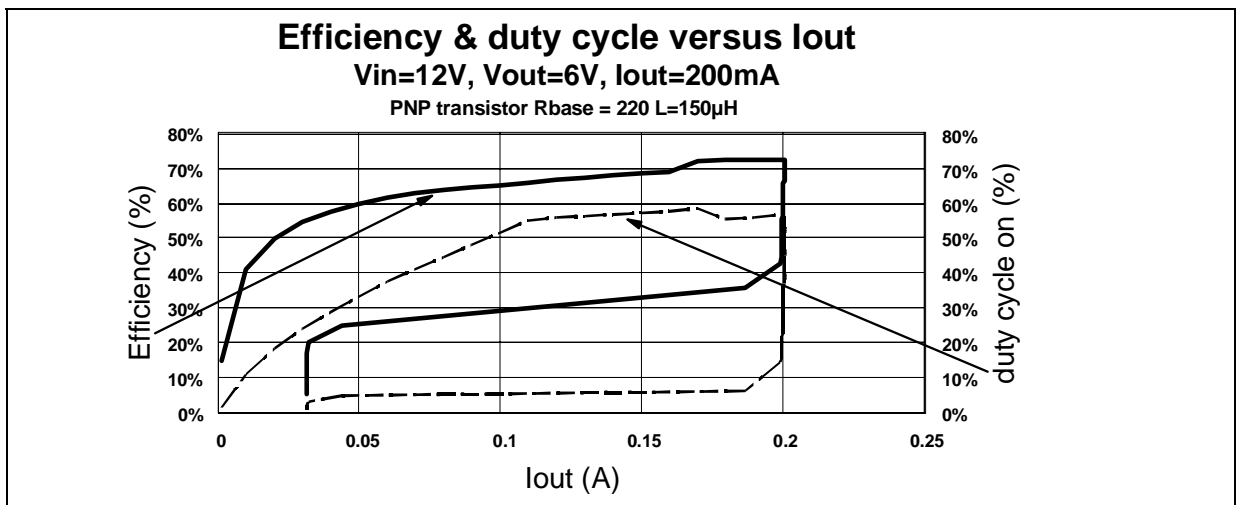
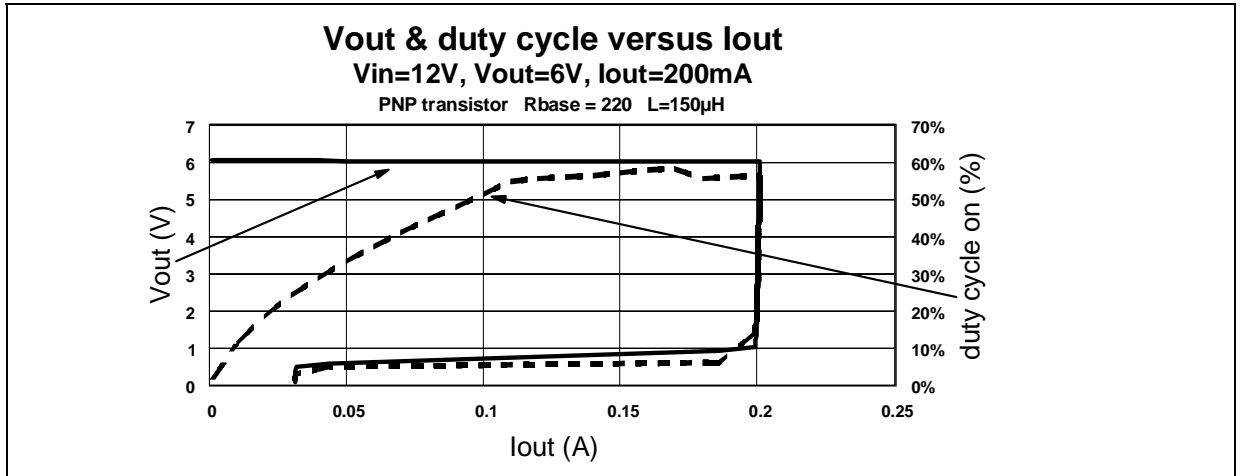

PACKAGE MECHANICAL DATA
14 PINS - PLASTIC MICROPACKAGE (SO)

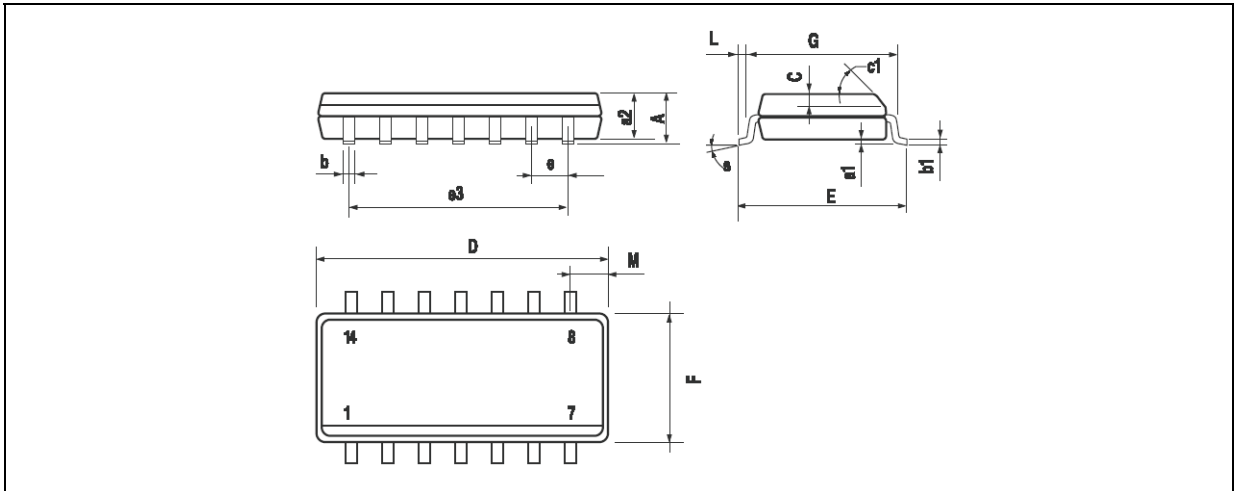

| Dim. | Millimeters | | | Inches | | |
|-------|-------------|------|------|--------|-------|-------|
| | Min. | Typ. | Max. | Min. | Typ. | Max. |
| A | | | 1.75 | | | 0.069 |
| a1 | 0.1 | | 0.2 | 0.004 | | 0.008 |
| a2 | | | 1.6 | | | 0.063 |
| b | 0.35 | | 0.46 | 0.014 | | 0.018 |
| b1 | 0.19 | | 0.25 | 0.007 | | 0.010 |
| C | | 0.5 | | | 0.020 | |
| c1 | 45° (typ.) | | | | | |
| D (1) | 8.55 | | 8.75 | 0.336 | | 0.344 |
| E | 5.8 | | 6.2 | 0.228 | | 0.244 |
| e | | 1.27 | | | 0.050 | |
| e3 | | 7.62 | | | 0.300 | |
| F (1) | 3.8 | | 4.0 | 0.150 | | 0.157 |
| G | 4.6 | | 5.3 | 0.181 | | 0.208 |
| L | 0.5 | | 1.27 | 0.020 | | 0.050 |
| M | | | 0.68 | | | 0.027 |
| S | 8° (max.) | | | | | |

Note : (1) D and F do not include mold flash or protrusions - Mold flash or protrusions shall not exceed 0.15mm (.066 inc) ONLY FOR DATA BOOK.

Information furnished is believed to be accurate and reliable. However, STMicroelectronics assumes no responsibility for the consequences of use of such information nor for any infringement of patents or other rights of third parties which may result from its use. No license is granted by implication or otherwise under any patent or patent rights of STMicroelectronics. Specifications mentioned in this publication are subject to change without notice. This publication supersedes and replaces all information previously supplied. STMicroelectronics products are not authorized for use as critical components in life support devices or systems without express written approval of STMicroelectronics.

© The ST logo is a registered trademark of STMicroelectronics

© 2006 STMicroelectronics - Printed in Italy - All Rights Reserved

STMicroelectronics GROUP OF COMPANIES

Australia - Brazil - China - Finland - France - Germany - Hong Kong - India - Italy - Japan - Malaysia - Malta - Morocco
 Singapore - Spain - Sweden - Switzerland - United Kingdom

© <http://www.st.com>

AMEYA360

Components Supply Platform

Authorized Distribution Brand :



Website :

Welcome to visit www.ameya360.com

Contact Us :

➤ Address :

401 Building No.5, JiuGe Business Center, Lane 2301, Yishan Rd
Minhang District, Shanghai , China

➤ Sales :

Direct +86 (21) 6401-6692

Email amall@ameya360.com

QQ 800077892

Skype [ameyasales1](#) [ameyasales2](#)

➤ Customer Service :

Email service@ameya360.com

➤ Partnership :

Tel +86 (21) 64016692-8333

Email mkt@ameya360.com