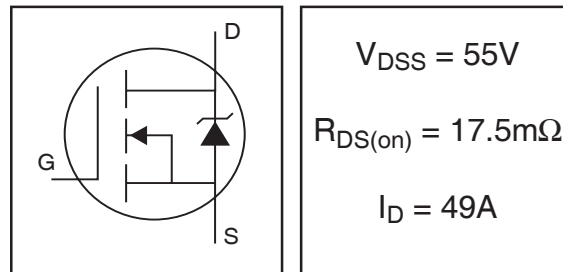


# IRFZ44NPbF

HEXFET® Power MOSFET

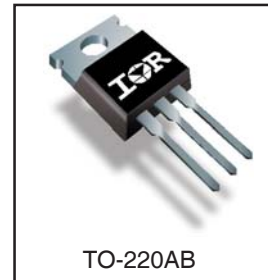
- Advanced Process Technology
- Ultra Low On-Resistance
- Dynamic dv/dt Rating
- 175°C Operating Temperature
- Fast Switching
- Fully Avalanche Rated
- Lead-Free



## Description

Advanced HEXFET® Power MOSFETs from International Rectifier utilize advanced processing techniques to achieve extremely low on-resistance per silicon area. This benefit, combined with the fast switching speed and ruggedized device design that HEXFET power MOSFETs are well known for, provides the designer with an extremely efficient and reliable device for use in a wide variety of applications.

The TO-220 package is universally preferred for all commercial-industrial applications at power dissipation levels to approximately 50 watts. The low thermal resistance and low package cost of the TO-220 contribute to its wide acceptance throughout the industry.



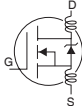
## Absolute Maximum Ratings

|                                 | Parameter  | Max.               | Units |
|---------------------------------|--|--------------------|-------|
| $I_D @ T_C = 25^\circ\text{C}$  | Continuous Drain Current, $V_{GS} @ 10\text{V}$  | 49                 | A     |
| $I_D @ T_C = 100^\circ\text{C}$ | Continuous Drain Current, $V_{GS} @ 10\text{V}$  | 35                 |       |
| $I_{DM}$                        | Pulsed Drain Current ①                           | 160                |       |
| $P_D @ T_C = 25^\circ\text{C}$  | Power Dissipation                                | 94                 | W     |
|                                 | Linear Derating Factor                           | 0.63               | W/°C  |
| $V_{GS}$                        | Gate-to-Source Voltage                           | $\pm 20$           | V     |
| $I_{AR}$                        | Avalanche Current ①                              | 25                 | A     |
| $E_{AR}$                        | Repetitive Avalanche Energy ①                    | 9.4                | mJ    |
| dv/dt                           | Peak Diode Recovery dv/dt ③                      | 5.0                | V/ns  |
| $T_J$                           | Operating Junction and Storage Temperature Range | -55 to + 175       | °C    |
| $T_{STG}$                       |  |                    |       |
|                                 |  |                    |       |
|                                 | Mounting torque, 6-32 or M3 screw                | 10 lbf•in (1.1N•m) |       |

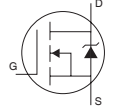
## Thermal Resistance

|                 | Parameter                           | Typ. | Max. | Units |
|-----------------|-------------------------------------|------|------|-------|
| $R_{\theta JC}$ | Junction-to-Case                    | —    | 1.5  | °C/W  |
| $R_{\theta CS}$ | Case-to-Sink, Flat, Greased Surface | 0.50 | —    |       |
| $R_{\theta JA}$ | Junction-to-Ambient                 | —    | 62   |       |

## Electrical Characteristics @ T<sub>J</sub> = 25°C (unless otherwise specified)

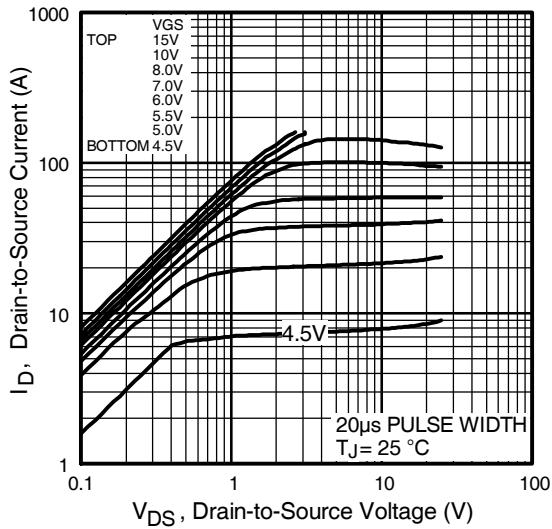
|  | Parameter                            | Min. | Typ.  | Max. | Units | Conditions   |
|--|--------------------------------------|------|-------|------|-------|--|
| V <sub>(BR)DSS</sub>                   | Drain-to-Source Breakdown Voltage    | 55   | —     | —    | V     | V <sub>GS</sub> = 0V, I <sub>D</sub> = 250μA   |
| ΔV <sub>(BR)DSS</sub> /ΔT <sub>J</sub> | Breakdown Voltage Temp. Coefficient  | —    | 0.058 | —    | V/°C  | Reference to 25°C, I <sub>D</sub> = 1mA  |
| R <sub>DS(on)</sub>                    | Static Drain-to-Source On-Resistance | —    | —     | 17.5 | mΩ    | V <sub>GS</sub> = 10V, I <sub>D</sub> = 25A ④  |
| V <sub>GS(th)</sub>                    | Gate Threshold Voltage               | 2.0  | —     | 4.0  | V     | V <sub>DS</sub> = V <sub>GS</sub> , I <sub>D</sub> = 250μA                           |
| g <sub>fs</sub>                        | Forward Transconductance             | 19   | —     | —    | S     | V <sub>DS</sub> = 25V, I <sub>D</sub> = 25A⑤   |
| I <sub>DSS</sub>                       | Drain-to-Source Leakage Current      | —    | —     | 25   | μA    | V <sub>DS</sub> = 55V, V <sub>GS</sub> = 0V  |
|  |                                      | —    | —     | 250  |       | V <sub>DS</sub> = 44V, V <sub>GS</sub> = 0V, T <sub>J</sub> = 150°C                  |
| I <sub>GSS</sub>                       | Gate-to-Source Forward Leakage       | —    | —     | 100  | nA    | V <sub>GS</sub> = 20V  |
|  | Gate-to-Source Reverse Leakage       | —    | —     | -100 |       | V <sub>GS</sub> = -20V   |
| Q <sub>g</sub>                         | Total Gate Charge                    | —    | —     | 63   | nC    | I <sub>D</sub> = 25A   |
| Q <sub>gs</sub>                        | Gate-to-Source Charge                | —    | —     | 14   |       | V <sub>DS</sub> = 44V  |
| Q <sub>gd</sub>                        | Gate-to-Drain ("Miller") Charge      | —    | —     | 23   |       | V <sub>GS</sub> = 10V, See Fig. 6 and 13   |
| t <sub>d(on)</sub>                     | Turn-On Delay Time                   | —    | 12    | —    | ns    | V <sub>DD</sub> = 28V  |
| t <sub>r</sub>                         | Rise Time                            | —    | 60    | —    |       | I <sub>D</sub> = 25A   |
| t <sub>d(off)</sub>                    | Turn-Off Delay Time                  | —    | 44    | —    |       | R <sub>G</sub> = 12Ω   |
| t <sub>f</sub>                         | Fall Time                            | —    | 45    | —    |       | V <sub>GS</sub> = 10V, See Fig. 10 ④   |
| L <sub>D</sub>                         | Internal Drain Inductance            | —    | 4.5   | —    | nH    | Between lead,<br>6mm (0.25in.)<br>from package<br>and center of die contact          |
| L <sub>S</sub>                         | Internal Source Inductance           | —    | 7.5   | —    |       |  |
| C <sub>iss</sub>                       | Input Capacitance                    | —    | 1470  | —    | pF    | V <sub>GS</sub> = 0V   |
| C <sub>oss</sub>                       | Output Capacitance                   | —    | 360   | —    |       | V <sub>DS</sub> = 25V  |
| C <sub>rss</sub>                       | Reverse Transfer Capacitance         | —    | 88    | —    |       | f = 1.0MHz, See Fig. 5   |
| E <sub>AS</sub>                        | Single Pulse Avalanche Energy②       | —    | 530③  | 150⑥ |       | mJ   |

## Source-Drain Ratings and Characteristics

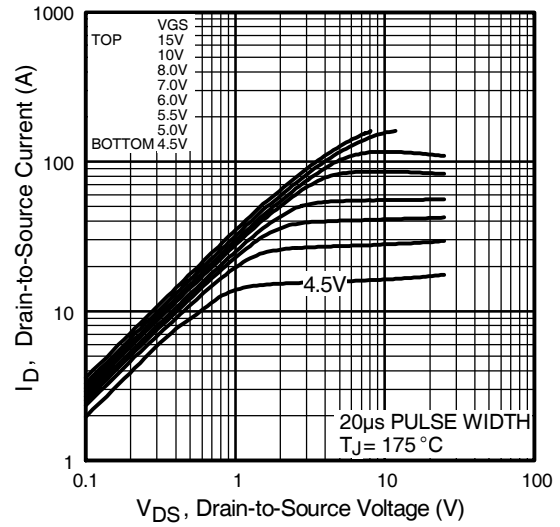
|                 | Parameter                                 | Min.   | Typ. | Max. | Units | Conditions   |
|-----------------|---|--|------|------|-------|--|
| I <sub>S</sub>  | Continuous Source Current<br>(Body Diode) | —  | —    | 49   | A     | MOSFET symbol<br>showing the<br>integral reverse<br>p-n junction diode.<br> |
| I <sub>SM</sub> | Pulsed Source Current<br>(Body Diode)①    | —  | —    | 160  |       |  |
| V <sub>SD</sub> | Diode Forward Voltage                     | —  | —    | 1.3  | V     | T <sub>J</sub> = 25°C, I <sub>S</sub> = 25A, V <sub>GS</sub> = 0V ④  |
| t <sub>rr</sub> | Reverse Recovery Time                     | —  | 63   | 95   | ns    | T <sub>J</sub> = 25°C, I <sub>F</sub> = 25A  |
| Q <sub>rr</sub> | Reverse Recovery Charge                   | —  | 170  | 260  | nC    | di/dt = 100A/μs ④  |
| t <sub>on</sub> | Forward Turn-On Time                      | Intrinsic turn-on time is negligible (turn-on is dominated by L <sub>S</sub> +L <sub>D</sub> ) |      |      |       |  |

### Notes:

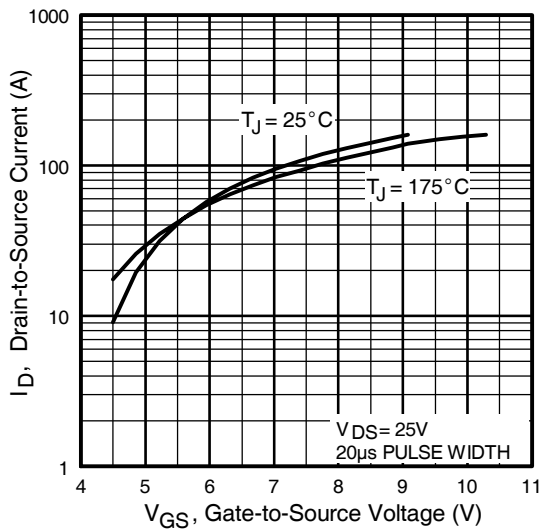
- ① Repetitive rating; pulse width limited by max. junction temperature. (See fig. 11)
- ② Starting T<sub>J</sub> = 25°C, L = 0.48mH  
R<sub>G</sub> = 25Ω, I<sub>AS</sub> = 25A. (See Figure 12)
- ③ I<sub>SD</sub> ≤ 25A, di/dt ≤ 230A/μs, V<sub>DD</sub> ≤ V<sub>(BR)DSS</sub>,  
T<sub>J</sub> ≤ 175°C
- ④ Pulse width ≤ 400μs; duty cycle ≤ 2%.
- ⑤ This is a typical value at device destruction and represents operation outside rated limits.
- ⑥ This is a calculated value limited to T<sub>J</sub> = 175°C .



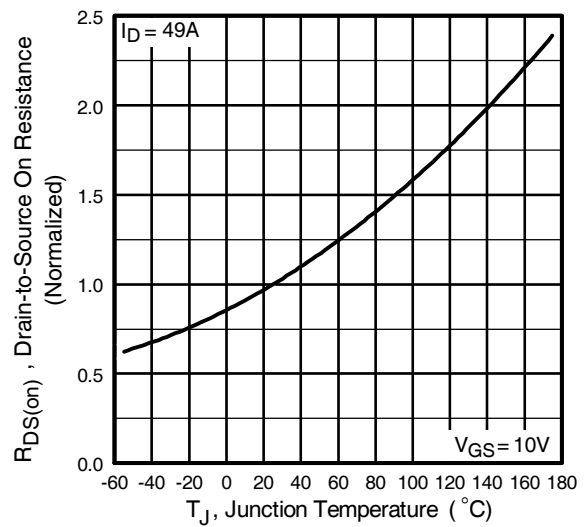
**Fig 1.** Typical Output Characteristics



**Fig 2.** Typical Output Characteristics

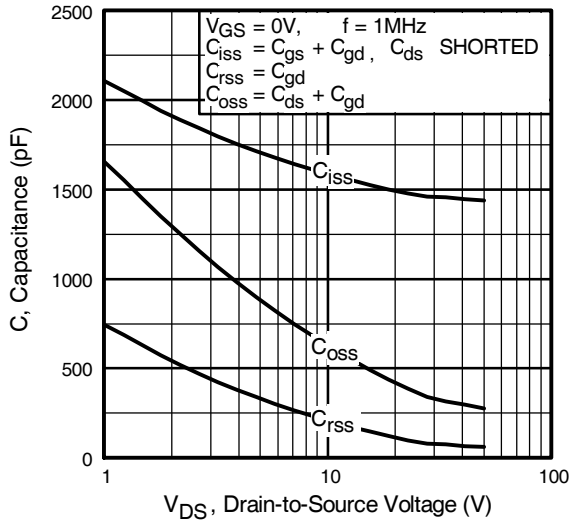


**Fig 3.** Typical Transfer Characteristics

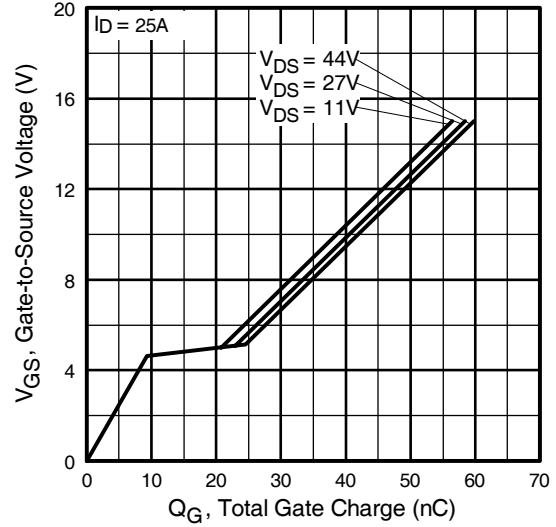


**Fig 4.** Normalized On-Resistance Vs. Temperature

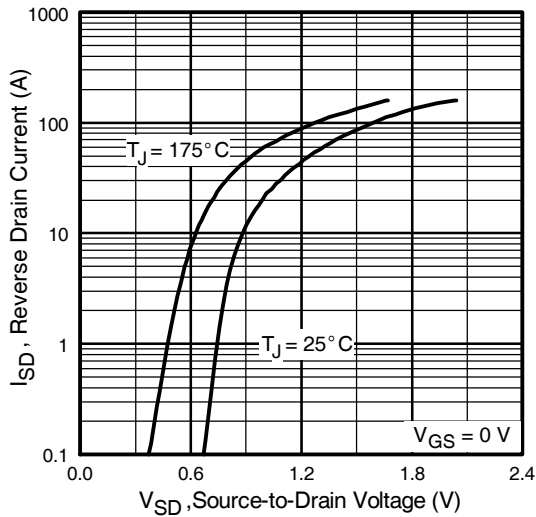
# IRFZ44NPbF



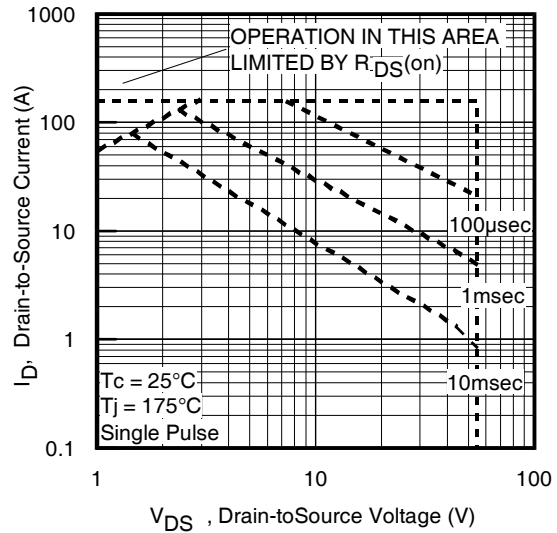
**Fig 5.** Typical Capacitance Vs. Drain-to-Source Voltage



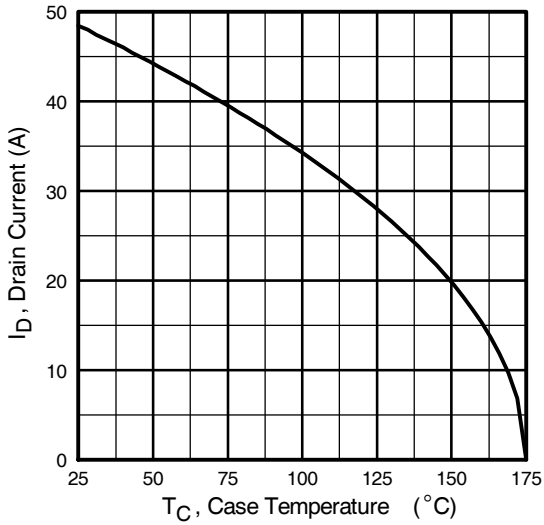
**Fig 6.** Typical Gate Charge Vs. Gate-to-Source Voltage



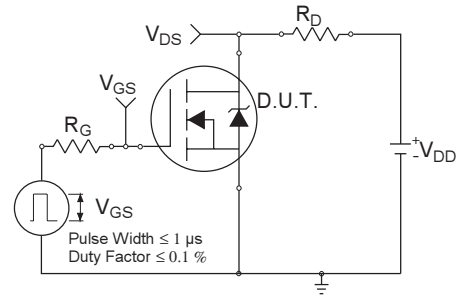
**Fig 7.** Typical Source-Drain Diode Forward Voltage



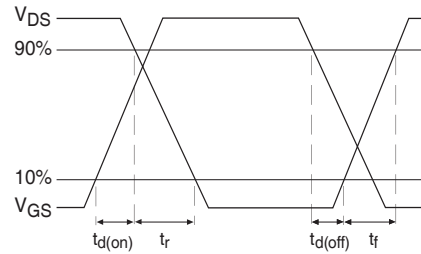
**Fig 8.** Maximum Safe Operating Area



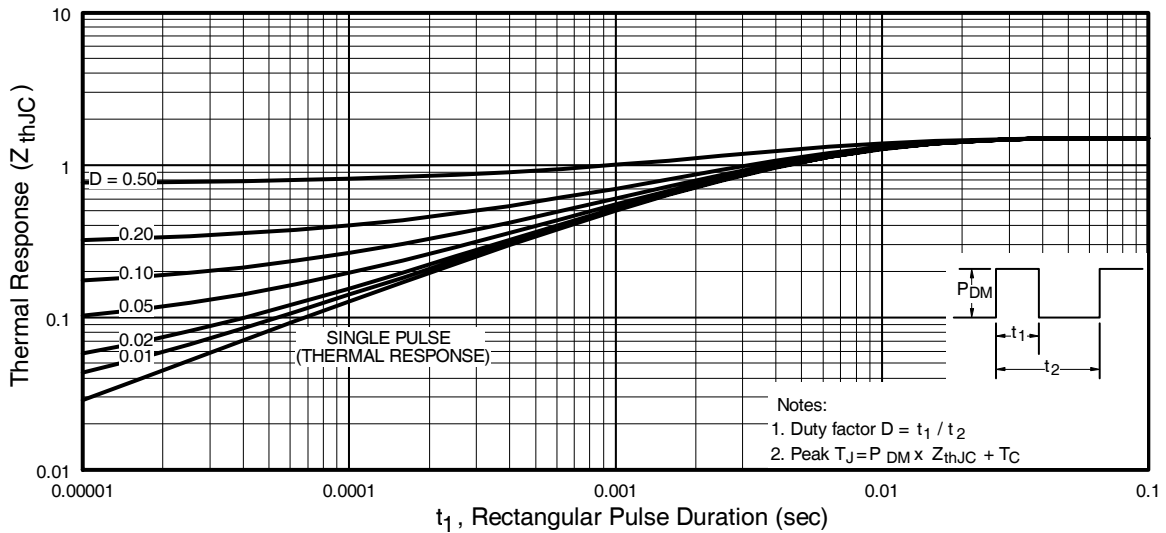
**Fig 9.** Maximum Drain Current Vs. Case Temperature



**Fig 10a.** Switching Time Test Circuit



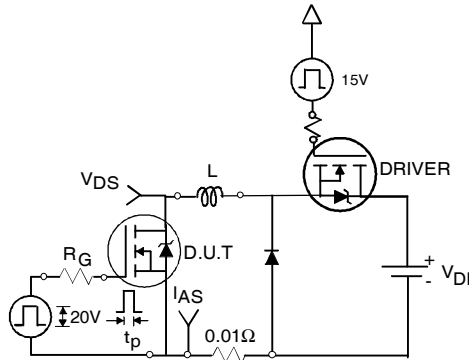
**Fig 10b.** Switching Time Waveforms



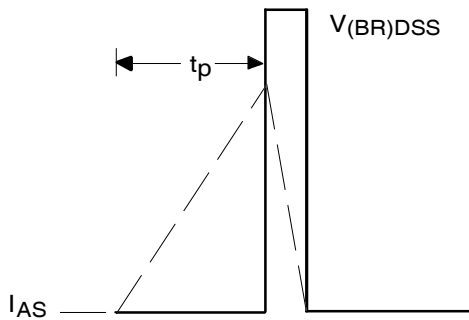
**Fig 11.** Maximum Effective Transient Thermal Impedance, Junction-to-Case

# IRFZ44NPbF

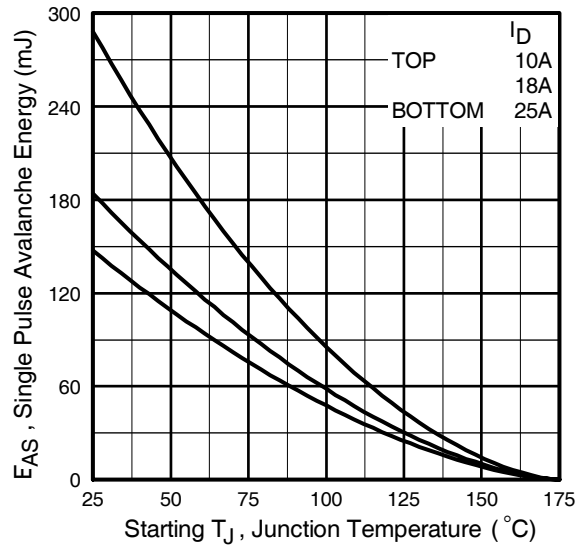
International  
**IR** Rectifier



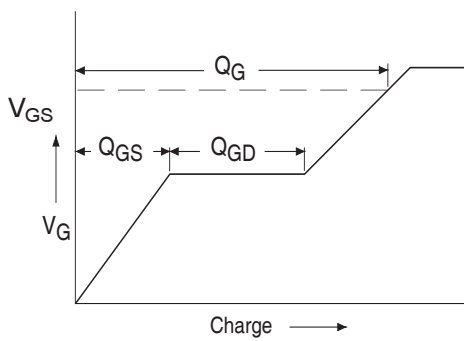
**Fig 12a.** Unclamped Inductive Test Circuit



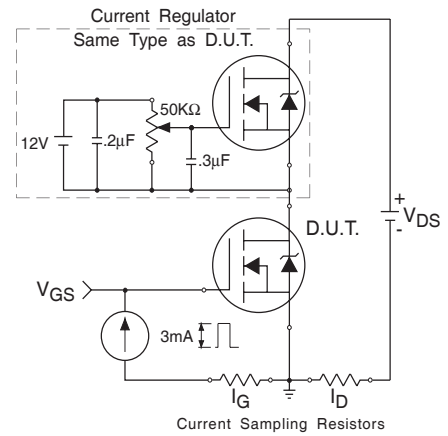
**Fig 12b.** Unclamped Inductive Waveforms



**Fig 12c.** Maximum Avalanche Energy Vs. Drain Current

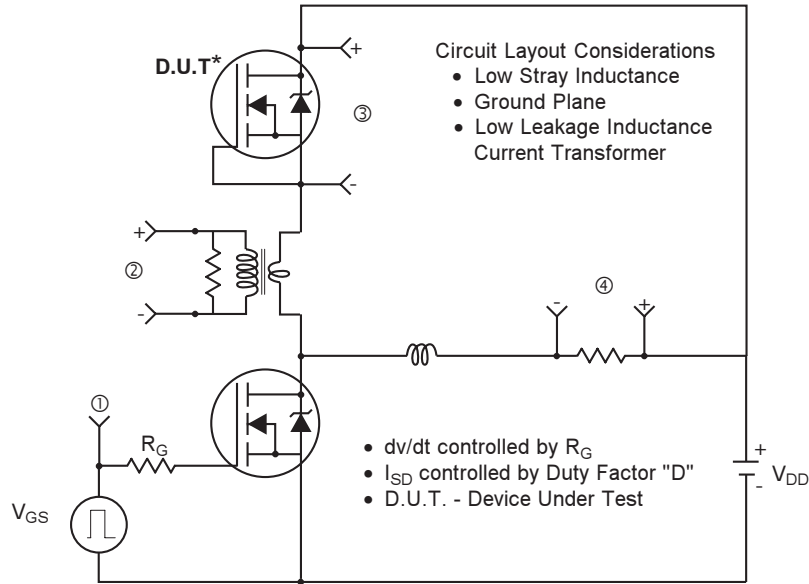


**Fig 13a.** Basic Gate Charge Waveform

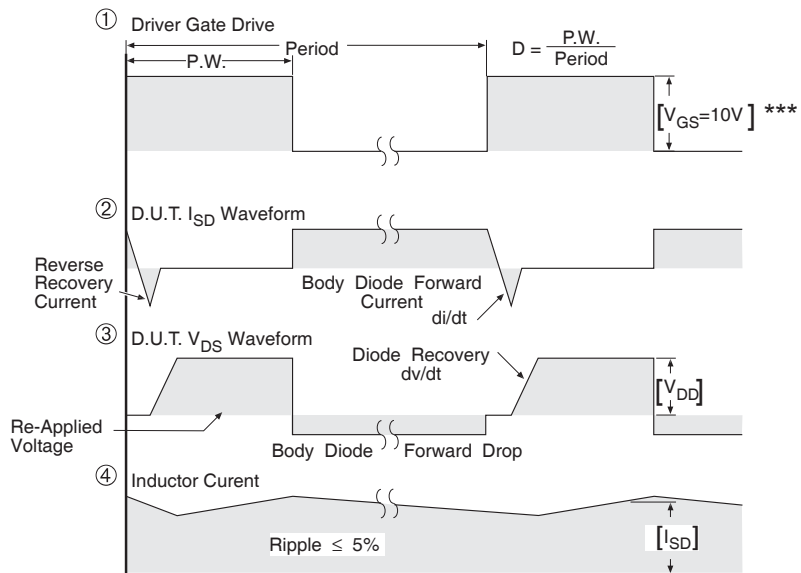


**Fig 13b.** Gate Charge Test Circuit

## Peak Diode Recovery dv/dt Test Circuit



\* Reverse Polarity of D.U.T for P-Channel



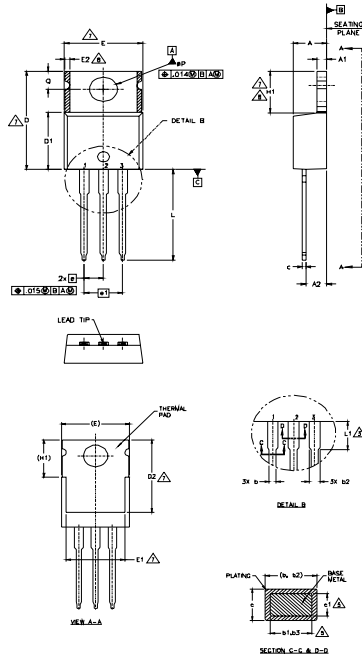
\*\*\*  $V_{GS} = 5.0V$  for Logic Level and 3V Drive Devices

**Fig 14.** For N-channel HEXFET® power MOSFETs

# IRFZ44NPbF

International  
**IR** Rectifier

## TO-220AB Package Outline (Dimensions are shown in millimeters (inches))



- NOTES:
- 1.- DIMENSIONING AND TOLERANCING AS PER ASME Y14.5 M- 1994.
  - 2.- DIMENSIONS ARE SHOWN IN INCHES [MILLIMETERS].
  - 3.- LEAD DIMENSION AND FINISH UNCONTROLLED IN L1.
  - 4.- DIMENSION D, D1 & E DO NOT INCLUDE MOLD FLASH. MOLD FLASH SHALL NOT EXCEED .005" (0.127) PER SIDE. THESE DIMENSIONS ARE MEASURED AT THE OUTERMOST EXTREMES OF THE PLASTIC BODY.
  - 5.- DIMENSION b1, b3 & c1 APPLY TO BASE METAL ONLY.
  - 6.- CONTROLLING DIMENSION : INCHES.
  - 7.- THERMAL PAD CONTOUR OPTIONAL WITHIN DIMENSIONS E,H1,D2 & E1
  - 8.- DIMENSION E2 X H1 DEFINE A ZONE WHERE STAMPING AND SINGULATION IRREGULARITIES ARE ALLOWED.
  - 9.- OUTLINE CONFORMS TO JEDEC TO-220, EXCEPT A2 (max.) AND D2 (min.) WHERE DIMENSIONS ARE DERIVED FROM THE ACTUAL PACKAGE OUTLINE.

| SYMBOL | DIMENSIONS  |       |          |      | NOTES |
|--------|-------------|-------|----------|------|-------|
|        | MILLIMETERS |       | INCHES   |      |       |
|        | MIN.        | MAX.  | MIN.     | MAX. |       |
| A      | 3.56        | 4.83  | .140     | .190 |       |
| A1     | 0.51        | 1.40  | .020     | .055 |       |
| A2     | 2.03        | 2.92  | .080     | .115 |       |
| b      | 0.38        | 1.01  | .015     | .040 |       |
| b1     | 0.38        | 0.97  | .015     | .038 | 5     |
| b2     | 1.14        | 1.78  | .045     | .070 |       |
| b3     | 1.14        | 1.73  | .045     | .068 | 5     |
| c      | 0.36        | 0.61  | .014     | .024 |       |
| c1     | 0.36        | 0.56  | .014     | .022 | 5     |
| D      | 14.22       | 16.51 | .560     | .650 | 4     |
| D1     | 8.38        | 9.02  | .330     | .355 |       |
| D2     | 11.68       | 12.88 | .460     | .507 | 7     |
| E      | 9.65        | 10.67 | .380     | .420 | 4,7   |
| E1     | 6.86        | 8.89  | .270     | .350 | 7     |
| E2     | -           | 0.76  | -        | .030 | 8     |
| e      | 2.54 BSC    |       | .100 BSC |      |       |
| e1     | 5.08 BSC    |       | .200 BSC |      |       |
| H1     | 5.84        | 6.86  | .230     | .270 | 7,8   |
| L      | 12.70       | 14.73 | .500     | .580 |       |
| L1     | -           | 6.35  | -        | .250 | 3     |
| øP     | 3.54        | 4.08  | .139     | .161 |       |
| Q      | 2.54        | 3.42  | .100     | .135 |       |

### LEAD ASSIGNMENTS

#### MOSEFT

- 1- GATE
- 2- DRAIN
- 3- SOURCE

#### IGBTs, CoPAKs

- 1- GATE
- 2- COLLECTOR
- 3- EMITTER

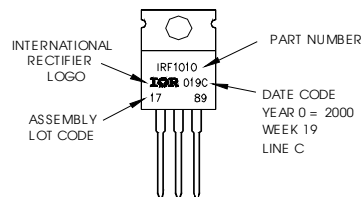
#### DIODES

- 1- ANODE/OPEN
- 2- CATHODE
- 3- ANODE

## TO-220AB Part Marking Information

EXAMPLE: THIS IS AN IRF1010  
LOT CODE 1789  
ASSEMBLED ON WW 19, 2000  
IN THE ASSEMBLY LINE "C"

Note: "P" in assembly line position  
indicates "Lead - Free"



### Notes:

1. For an Automotive Qualified version of this part please see <http://www.irf.com/product-info/aut/>
2. For the most current drawing please refer to IR website at <http://www.irf.com/package/>

Data and specifications subject to change without notice.  
This product has been designed and qualified for the Industrial market.  
Qualification Standards can be found on IR's Web site.

International  
**IR** Rectifier

IR WORLD HEADQUARTERS: 233 Kansas St., El Segundo, California 90245, USA Tel: (310) 252-7105  
TAC Fax: (310) 252-7903

Visit us at [www.irf.com](http://www.irf.com) for sales contact information.09/2010

[www.irf.com](http://www.irf.com)

# AMEYA360

## Components Supply Platform

Authorized Distribution Brand :



Website :

Welcome to visit [www.ameya360.com](http://www.ameya360.com)

Contact Us :

➤ Address :

401 Building No.5, JiuGe Business Center, Lane 2301, Yishan Rd  
Minhang District, Shanghai , China

➤ Sales :

Direct +86 (21) 6401-6692

Email [amall@ameya360.com](mailto:amall@ameya360.com)

QQ 800077892

Skype [ameyasales1](#) [ameyasales2](#)

➤ Customer Service :

Email [service@ameya360.com](mailto:service@ameya360.com)

➤ Partnership :

Tel +86 (21) 64016692-8333

Email [mkt@ameya360.com](mailto:mkt@ameya360.com)