

## Low-Cost, UCSP/SOT23, Micropower, High-Side Current-Sense Amplifier with Voltage Output

### General Description

The MAX4372 low-cost, precision, high-side current-sense amplifier is available in a tiny, space-saving SOT23-5-pin package. Offered in three gain versions (T = 20V/V, F = 50V/V, and H = 100V/V), this device operates from a single 2.7V to 28V supply and consumes only 30 $\mu$ A. It features a voltage output that eliminates the need for gain-setting resistors and is ideal for today's notebook computers, cell phones, and other systems where battery/DC current monitoring is critical.

High-side current monitoring is especially useful in battery-powered systems since it does not interfere with the ground path of the battery charger. The input common-mode range of 0 to 28V is independent of the supply voltage and ensures that the current-sense feedback remains viable even when connected to a 2-cell battery pack in deep discharge.

The user can set the full-scale current reading by choosing the device (T, F, or H) with the desired voltage gain and selecting the appropriate external sense resistor. This capability offers a high level of integration and flexibility, resulting in a simple and compact current-sense solution. For higher bandwidth applications, refer to the MAX4173T/F/H data sheet.

### Applications

- Power-Management Systems
- General-System/Board-Level Current Monitoring
- Notebook Computers
- Portable/Battery-Powered Systems
- Smart-Battery Packs/Chargers
- Cell Phones
- Precision-Current Sources

### Pin Configurations

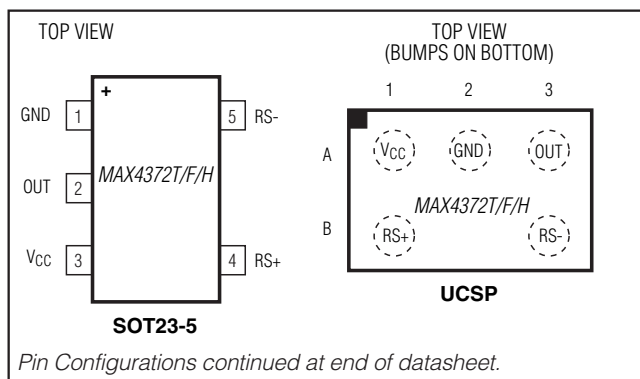

### Features

- ◆ Low-Cost, Compact Current-Sense Solution
- ◆ 30 $\mu$ A Supply Current
- ◆ 2.7V to 28V Operating Supply
- ◆ 0.18% Full-Scale Accuracy
- ◆ 0.3mV Input Offset Voltage
- ◆ Low 1.5 $\Omega$  Output Impedance
- ◆ Three Gain Versions Available
  - 20V/V (MAX4372T)
  - 50V/V (MAX4372F)
  - 100V/V (MAX4372H)
- ◆ High Accuracy +2V to +28V Common-Mode Range, Functional Down to 0V, Independent of Supply Voltage
- ◆ Available in a Space-Saving 5-Pin SOT23 Package and 3 x 2 UCSP™ (1mm x 1.5mm) Package

### Ordering Information

| PART          | TEMP RANGE     | PIN-PACKAGE | TOP MARK |
|---------------|----------------|-------------|----------|
| MAX4372TEUK+T | -40°C to +85°C | 5 SOT23-5   | ADIU     |
| MAX4372TESA+T | -40°C to +85°C | 8 SO        | —        |
| MAX4372TEBT+T | -40°C to +85°C | 3 x 2 UCSP  | ACX      |

+ Denotes a lead(Pb)-free/RoHS-compliant package.  
T = Tape and reel.

**Note:** Gain values are as follows: 20V/V for the T version, 50V/V for the F version, and 100V/V for the H version.

**Ordering Information continued at end of datasheet.**

### Typical Operating Circuit

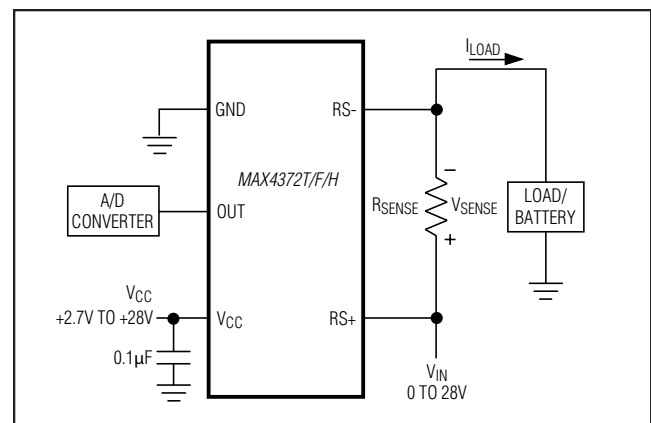

UCSP is a trademark of Maxim Integrated Products, Inc.

# MAX4372T/F/H

## Low-Cost, UCSP/SOT23, Micropower, High-Side Current-Sense Amplifier with Voltage Output

### ABSOLUTE MAXIMUM RATINGS

V<sub>CC</sub>, RS+, RS- to GND .....-0.3V to +30V  
 OUT to GND .....-0.3V to +15V  
 Differential Input Voltage (V<sub>RS+</sub> - V<sub>RS-</sub>) .....±0.3V  
 Current into Any Pin.....±10mA  
 Continuous Power Dissipation (T<sub>A</sub> = +70°C)  
   5-Pin SOT23 (derate 3.9mW/°C above +70°C).....312.6mW  
   8-Pin SO (derate 7.4mW/°C above +70°C).....588.2mW  
   3 x 2 UCSP (derate 3.4mW/°C above +70°C) .....273.2mW

Operating Temperature Range .....-40°C to +85°C  
 Storage Temperature Range .....-65°C to +150°C  
 Lead Temperature (soldering, 10s).....+300°C  
 Soldering Temperature (reflow).....+300°C

Stresses beyond those listed under "Absolute Maximum Ratings" may cause permanent damage to the device. These are stress ratings only, and functional operation of the device at these or any other conditions beyond those indicated in the operational sections of the specifications is not implied. Exposure to absolute maximum rating conditions for extended periods may affect device reliability.

### ELECTRICAL CHARACTERISTICS

(V<sub>RS+</sub> = 0 to 28V, V<sub>CC</sub> = 2.7V to 28V, V<sub>SENSE</sub> = 0V, R<sub>LOAD</sub> = 1MΩ, T<sub>A</sub> = T<sub>MIN</sub> to T<sub>MAX</sub>, unless otherwise noted. Typical values are at T<sub>A</sub> = +25°C.) (Note 1)

| PARAMETER                         | SYMBOL                              | CONDITIONS                                                                                                    | MIN               | TYP   | MAX  | UNITS |
|-----------------------------------|-------------------------------------|---------------------------------------------------------------------------------------------------------------|-------------------|-------|------|-------|
| Operating Voltage Range (Note 2)  | V <sub>CC</sub>                     |                                                                                                               | 2.7               |       | 28   | V     |
| Common-Mode Input Range (Note 3)  | V <sub>CMR</sub>                    |                                                                                                               | 0                 |       | 28   | V     |
| Common-Mode Rejection             | CMR                                 | V <sub>RS+</sub> > 2V                                                                                         |                   | 85    |      | dB    |
| Supply Current                    | I <sub>CC</sub>                     | V <sub>RS+</sub> > 2V, V <sub>SENSE</sub> = 5mV                                                               |                   | 30    | 60   | μA    |
| Leakage Current                   | I <sub>RS+</sub> , I <sub>RS-</sub> | V <sub>CC</sub> = 0V, V <sub>RS+</sub> = 28V                                                                  |                   | 0.05  | 1.2  | μA    |
| Input Bias Current                | I <sub>RS+</sub>                    | V <sub>RS+</sub> > 2V                                                                                         | 0                 |       | 1    | μA    |
|                                   |                                     | V <sub>RS+</sub> ≤ 2V                                                                                         | -25               |       | 2    |       |
|                                   | I <sub>RS-</sub>                    | V <sub>RS+</sub> > 2V                                                                                         | 0                 |       | 2    |       |
|                                   |                                     | V <sub>RS+</sub> ≤ 2V                                                                                         | -50               |       | 2    |       |
| Full-Scale Sense Voltage (Note 4) | V <sub>SENSE</sub>                  | Gain = 20V/V or 50V/V                                                                                         |                   | 150   |      | mV    |
|                                   |                                     | Gain = 100V/V                                                                                                 |                   | 100   |      |       |
| Input Offset Voltage (Note 5)     | V <sub>OS</sub>                     | T <sub>A</sub> = +25°C<br>V <sub>CC</sub> = V <sub>RS+</sub> = 12V                                            | MAX4372_ESA       | 0.3   | ±0.8 | mV    |
|                                   |                                     |                                                                                                               | MAX4372_EUK, _EBT | 0.3   | ±1.3 |       |
|                                   |                                     | T <sub>A</sub> = T <sub>MIN</sub> to T <sub>MAX</sub><br>V <sub>CC</sub> = V <sub>RS+</sub> = 12V             | MAX4372_ESA       |       | ±1.1 |       |
|                                   |                                     |                                                                                                               | MAX4372_EUK, _EBT |       | ±1.9 |       |
| Full-Scale Accuracy (Note 5)      |                                     | V <sub>SENSE</sub> = 100mV, V <sub>CC</sub> = 12V,<br>V <sub>RS+</sub> = 12V, T <sub>A</sub> = +25°C (Note 7) |                   | ±0.18 | ±3   | %     |
| Total OUT Voltage Error (Note 6)  |                                     | V <sub>SENSE</sub> = 100mV, V <sub>CC</sub> = 12V,<br>V <sub>RS+</sub> = 12V (Note 7)                         |                   |       | ±6   | %     |
|                                   |                                     | V <sub>SENSE</sub> = 100mV, V <sub>CC</sub> = 28V,<br>V <sub>RS+</sub> = 28V (Note 7)                         |                   | ±0.15 | ±7   |       |
|                                   |                                     | V <sub>SENSE</sub> = 100mV, V <sub>CC</sub> = 12V,<br>V <sub>RS+</sub> = 0.1V (Note 7)                        |                   | ±1    | ±28  |       |
|                                   |                                     | V <sub>SENSE</sub> = 6.25mV, V <sub>CC</sub> = 12V,<br>V <sub>RS+</sub> = 12V (Note 8)                        |                   | ±0.15 |      |       |

# MAX4372T/F/H

## Low-Cost, UCSP/SOT23, Micropower, High-Side Current-Sense Amplifier with Voltage Output

### ELECTRICAL CHARACTERISTICS (continued)

( $V_{RS+} = 0$  to 28V,  $V_{CC} = 2.7$ V to 28V,  $V_{SENSE} = 0$ V,  $R_{LOAD} = 1$ M $\Omega$ ,  $T_A = T_{MIN}$  to  $T_{MAX}$ , unless otherwise noted. Typical values are at  $T_A = +25^{\circ}$ C.) (Note 1)

| PARAMETER                               | SYMBOL            | CONDITIONS                                                                         |                                          | MIN | TYP        | MAX       | UNITS    |
|-----------------------------------------|-------------------|------------------------------------------------------------------------------------|------------------------------------------|-----|------------|-----------|----------|
| OUT Low Voltage<br>(MAX4372T, MAX4372F) | $V_{OL}$          | $V_{CC} = 2.7$ V,<br>$V_{SENSE} = -10$ mV<br>$V_{RS+} = 28$ V                      | $I_{OUT} = 10\mu$ A                      |     | 2.6        |           | mV       |
|                                         |                   |                                                                                    | $I_{OUT} = 100\mu$ A                     |     | 9          | 65        |          |
| OUT Low Voltage<br>(MAX4372H)           | $V_{OL}$          | $V_{CC} = 2.7$ V,<br>$V_{SENSE} = -10$ mV<br>$V_{RS+} = 12$ V                      | $I_{OUT} = 10\mu$ A                      |     | 2.6        |           | mV       |
|                                         |                   |                                                                                    | $I_{OUT} = 100\mu$ A                     |     | 9          | 65        |          |
| OUT High Voltage                        | $V_{CC} - V_{OH}$ | $V_{RS+} = 28$ V, $V_{CC} = 2.7$ V, $I_{OUT} = -500\mu$ A,<br>$V_{SENSE} = 250$ mV |                                          |     | 0.1        | 0.25      | V        |
| -3dB Bandwidth                          | BW                | $V_{RS+} = 12$ V,<br>$V_{CC} = 12$ V,<br>$C_{LOAD} = 10$ pF                        | $V_{SENSE} = 20$ mV,<br>gain = 20V/V     |     | 275        |           | kHz      |
|                                         |                   |                                                                                    | $V_{SENSE} = 20$ mV,<br>gain = 50V/V     |     | 200        |           |          |
|                                         |                   |                                                                                    | $V_{SENSE} = 20$ mV,<br>gain = 100V/V    |     | 110        |           |          |
|                                         |                   |                                                                                    | $V_{SENSE} = 6.25$ mV                    |     | 50         |           |          |
| Gain                                    |                   | MAX4372T                                                                           |                                          |     | 20         |           | V/V      |
|                                         |                   | MAX4372F                                                                           |                                          |     | 50         |           |          |
|                                         |                   | MAX4372H                                                                           |                                          |     | 100        |           |          |
| Gain Accuracy                           |                   | $V_{SENSE} = 20$ mV<br>to 100mV, $V_{RS+} = 12$ V                                  | $T_A = +25^{\circ}$ C                    |     | $\pm 0.25$ | $\pm 2.5$ | %        |
|                                         |                   |                                                                                    | $T_A = -40^{\circ}$ C to $+85^{\circ}$ C |     |            | $\pm 5.5$ |          |
| OUT Settling Time to 1% of Final Value  |                   | Gain = 20V/V,<br>$V_{CC} = 12$ V,<br>$V_{RS+} = 12$ V,<br>$C_{LOAD} = 10$ pF       | $V_{SENSE} = 6.25$ mV to<br>100mV        |     | 20         |           | $\mu$ s  |
|                                         |                   |                                                                                    | $V_{SENSE} = 100$ mV to<br>6.25mV        |     | 20         |           |          |
| Capacitive-Load Stability               |                   | No sustained oscillations                                                          |                                          |     | 1000       |           | pF       |
| OUT Output Resistance                   | $R_{OUT}$         | $V_{SENSE} = 100$ mV                                                               |                                          |     | 1.5        |           | $\Omega$ |
| Power-Supply Rejection                  | PSR               | $V_{OUT} = 2$ V, $V_{RS+} > 2$ V                                                   |                                          | 75  | 85         |           | dB       |
| Power-Up Time to 1% of Final Value      |                   | $V_{CC} = 12$ V, $V_{RS+} = 12$ V,<br>$V_{SENSE} = 100$ mV, $C_{LOAD} = 10$ pF     |                                          |     | 0.5        |           | ms       |
| Saturation Recovery Time<br>(Note 9)    |                   | $V_{CC} = 12$ V, $V_{RS+} = 12$ V, $C_{LOAD} = 10$ pF                              |                                          |     | 0.1        |           | ms       |

**Note 1:** All devices are 100% production tested at  $T_A = +25^{\circ}$ C. All temperature limits are guaranteed by design.

**Note 2:** Guaranteed by PSR test.

**Note 3:** Guaranteed by OUT Voltage Error test.

**Note 4:** Output voltage is internally clamped not to exceed 12V.

**Note 5:**  $V_{OS}$  is extrapolated from the gain accuracy tests.

**Note 6:** Total OUT voltage error is the sum of gain and offset voltage errors.

**Note 7:** Measured at  $I_{OUT} = -500\mu$ A ( $R_{LOAD} = 4$ k $\Omega$  for gain = 20V/V,  $R_{LOAD} = 10$ k $\Omega$  for gain = 50V/V,  $R_{LOAD} = 20$ k $\Omega$  for gain = 100V/V).

**Note 8:** 6.25mV = 1/16 of 100mV full-scale voltage (C/16).

**Note 9:** The device will not reverse phase when overdriven.

# MAX4372T/F/H

## Low-Cost, UCSP/SOT23, Micropower, High-Side Current-Sense Amplifier with Voltage Output

### Typical Operating Characteristics

( $V_{CC} = 12V$ ,  $V_{RS+} = 12V$ ,  $V_{SENSE} = 100mV$ ,  $T_A = +25^\circ C$ , unless otherwise noted.)

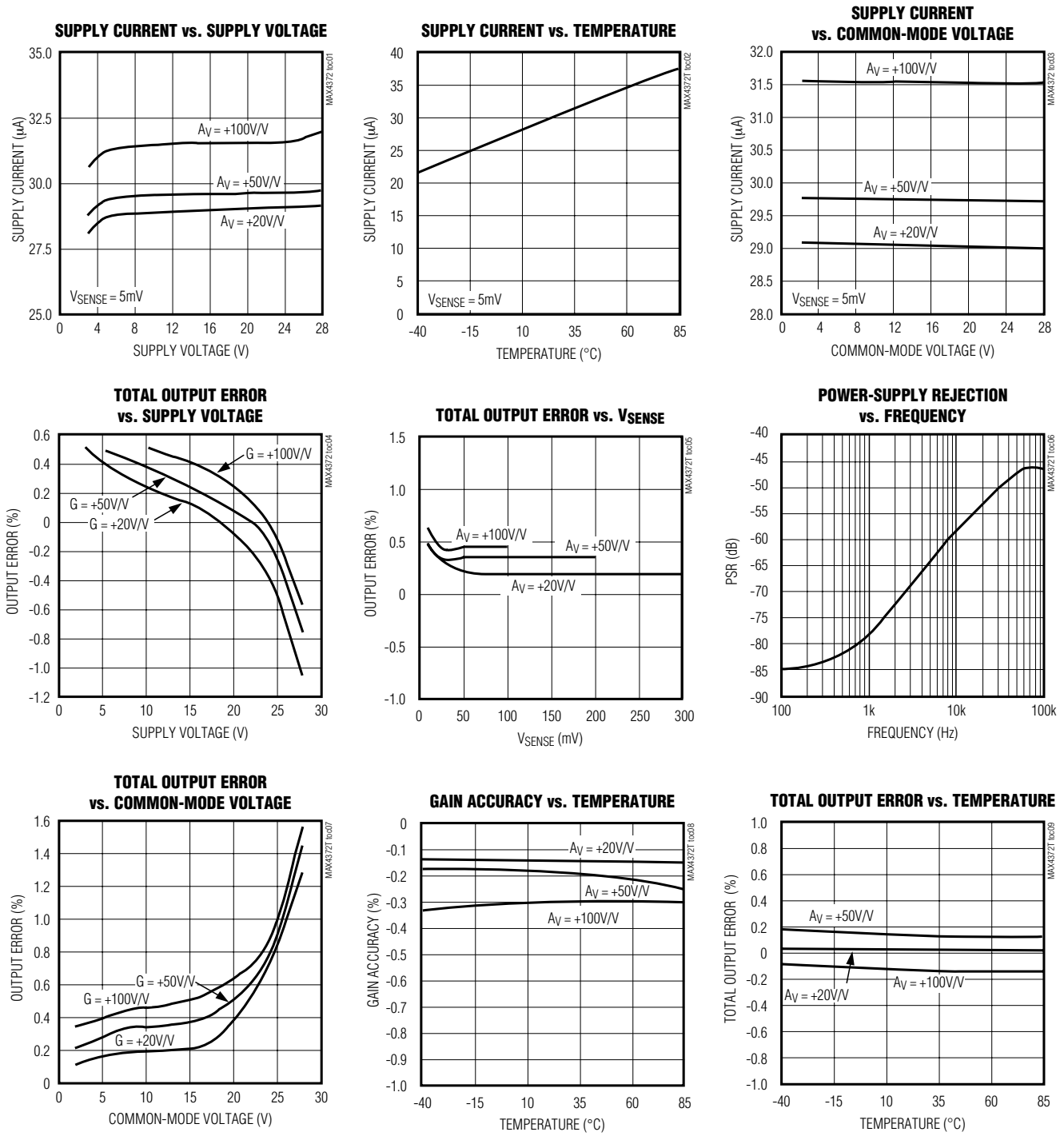

# MAX4372T/F/H

## Low-Cost, UCSP/SOT23, Micropower, High-Side Current-Sense Amplifier with Voltage Output

### Typical Operating Characteristics (continued)

( $V_{CC} = 12V$ ,  $V_{RS+} = 12V$ ,  $V_{SENSE} = 100mV$ ,  $T_A = +25^\circ C$ , unless otherwise noted.)

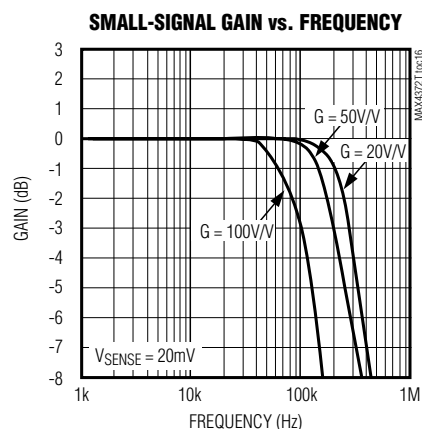
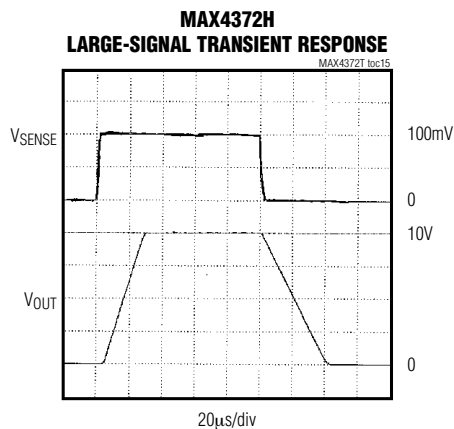
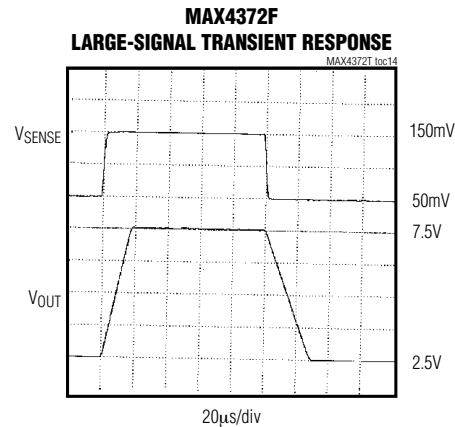
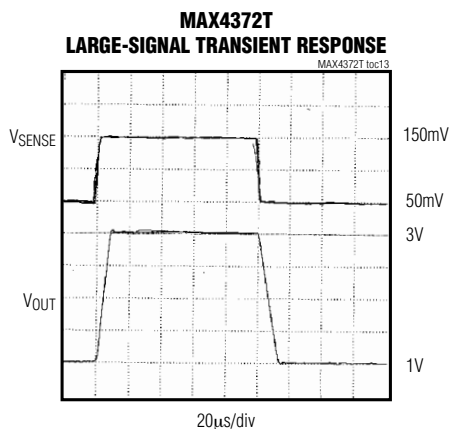
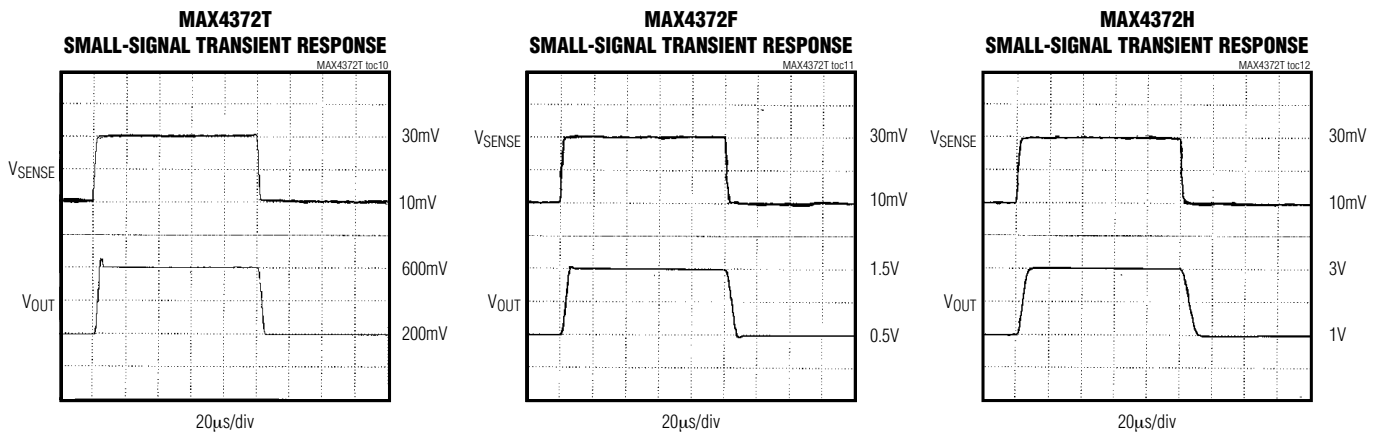

# MAX4372T/F/H

## Low-Cost, UCSP/SOT23, Micropower, High-Side Current-Sense Amplifier with Voltage Output

### Pin/Bump Description

| PIN   |         | BUMP | NAME     | FUNCTION                                                                                           |
|-------|---------|------|----------|----------------------------------------------------------------------------------------------------|
| SOT23 | SO      | UCSP |          |                                                                                                    |
| 1     | 3       | A2   | GND      | Ground                                                                                             |
| 2     | 4       | A3   | OUT      | Output Voltage. $V_{OUT}$ is proportional to the magnitude of $V_{SENSE}$ ( $V_{RS+} - V_{RS-}$ ). |
| 3     | 1       | A1   | $V_{CC}$ | Supply Voltage. Use at least a 0.1 $\mu$ F capacitor to decouple $V_{CC}$ from fast transients.    |
| 4     | 8       | B1   | $RS+$    | Power Connection to the External Sense Resistor                                                    |
| 5     | 6       | B3   | $RS-$    | Load-Side Connection to the External Sense Resistor                                                |
| —     | 2, 5, 7 | —    | N.C.     | No Connection. Not internally connected.                                                           |

### Detailed Description

The MAX4372 high-side current-sense amplifier features a 0 to 28V input common-mode range that is independent of supply voltage. This feature allows the monitoring of current flow out of a battery in deep discharge, and also enables high-side current sensing at voltages far in excess of the supply voltage ( $V_{CC}$ ).

Current flows through the sense resistor, generating a sense voltage (Figure 1). Since A1's inverting input is high impedance, the voltage on the negative terminal equals  $V_{IN} - V_{SENSE}$ . A1 forces its positive terminal to match its negative terminal; therefore, the voltage across  $R_{G1}$  ( $V_{IN} - V_{1-}$ ) equals  $V_{SENSE}$ . This creates a current to flow through  $R_{G1}$  equal to  $V_{SENSE} / R_{G1}$ . The transistor and current mirror amplify the current by a factor of  $\beta$ . This makes the current flowing out of the current mirror equal to:

$$I_M = \beta V_{SENSE} / R_{G1}$$

A2's positive terminal presents high impedance, so this current flows through  $R_{GD}$ , with the following result:

$$V_{2+} = R_{GD} \beta \cdot V_{SENSE} / R_{G1}$$

$R_1$  and  $R_2$  set the closed-loop gain for A2, which amplifies  $V_{2+}$ , yielding:

$$V_{OUT} = R_{GD} \cdot \beta \cdot V_{SENSE} / R_{G1} (1 + R_2 / R_1)$$

The gain of the device equals:

$$\frac{V_{OUT}}{V_{SENSE}} = R_{GD} \cdot \beta (1 + R_2 / R_1) / R_{G1}$$

### Applications Information

#### Recommended Component Values

The MAX4372 operates over a wide variety of current ranges with different sense resistors. Table 1 lists common resistor values for typical operation of the MAX4372.

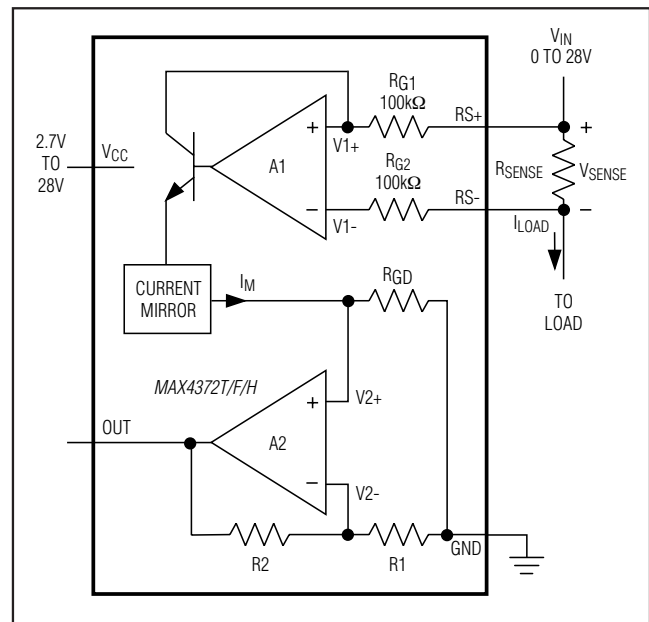

Figure 1. Functional Diagram

#### Choosing RSENSE

Given the gain and maximum load current, select  $R_{SENSE}$  such that  $V_{OUT}$  does not exceed  $V_{CC} - 0.25V$  or 10V. To measure lower currents more accurately, use a high value for  $R_{SENSE}$ . A higher value develops a higher sense voltage, which overcomes offset voltage errors of the internal current amplifier.

In applications monitoring very high current, ensure  $R_{SENSE}$  is able to dissipate its own  $I^2R$  losses. If the resistor's rated power dissipation is exceeded, its value may drift or it may fail altogether, causing a differential voltage across the terminals in excess of the absolute maximum ratings.

# MAX4372T/F/H

## Low-Cost, UCSP/SOT23, Micropower, High-Side Current-Sense Amplifier with Voltage Output

Table 1. Recommended Component Values

| FULL-SCALE LOAD CURRENT, I <sub>LOAD</sub> (A) | CURRENT-SENSE RESISTOR, R <sub>SENSE</sub> (mΩ) | GAIN (V/V) | FULL-SCALE OUTPUT VOLTAGE (FULL-SCALE V <sub>SENSE</sub> = 100mV), V <sub>OUT</sub> (V) |
|------------------------------------------------|-------------------------------------------------|------------|-----------------------------------------------------------------------------------------|
| 0.1                                            | 1000                                            | 20         | 2.0                                                                                     |
|                                                |                                                 | 50         | 5.0                                                                                     |
|                                                |                                                 | 100        | 10.0                                                                                    |
| 1                                              | 100                                             | 20         | 2.0                                                                                     |
|                                                |                                                 | 50         | 5.0                                                                                     |
|                                                |                                                 | 100        | 10.0                                                                                    |
| 5                                              | 20                                              | 20         | 2.0                                                                                     |
|                                                |                                                 | 50         | 5.0                                                                                     |
|                                                |                                                 | 100        | 10.0                                                                                    |
| 10                                             | 10                                              | 20         | 2.0                                                                                     |
|                                                |                                                 | 50         | 5.0                                                                                     |
|                                                |                                                 | 100        | 10.0                                                                                    |

### Using a PC Board Trace as R<sub>SENSE</sub>

If the cost of R<sub>SENSE</sub> is an issue and accuracy is not critical, use the alternative solution shown in Figure 2. This solution uses copper PC board traces to create a sense resistor. The resistivity of a 0.1-inch-wide trace of 2-ounce copper is about 30mΩ/ft. The resistance temperature coefficient of copper is fairly high (approximately 0.4%/°C), so systems that experience a wide temperature variance must compensate for this effect. In addition, self-heating will introduce a nonlinearity error. Do not exceed the maximum power dissipation of the copper trace.

For example, the MAX4372T (with a maximum load current of 10A and an R<sub>SENSE</sub> of 5mΩ) creates a full-scale V<sub>SENSE</sub> of 50mV that yields a maximum V<sub>OUT</sub> of 1V. R<sub>SENSE</sub>, in this case, requires about 2 inches of 0.1-inch-wide copper trace.

### UCSP Applications Information

For the latest application details on UCSP construction, dimensions, tape carrier information, printed circuit board techniques, bump-pad layout, and recommended reflow temperature profile, as well as the latest information on reliability testing results, go to the Maxim's website at [www.maxim-ic.com/ucsp](http://www.maxim-ic.com/ucsp) to find the Application Note: UCSP—A Wafer-Level Chip-Scale Package.

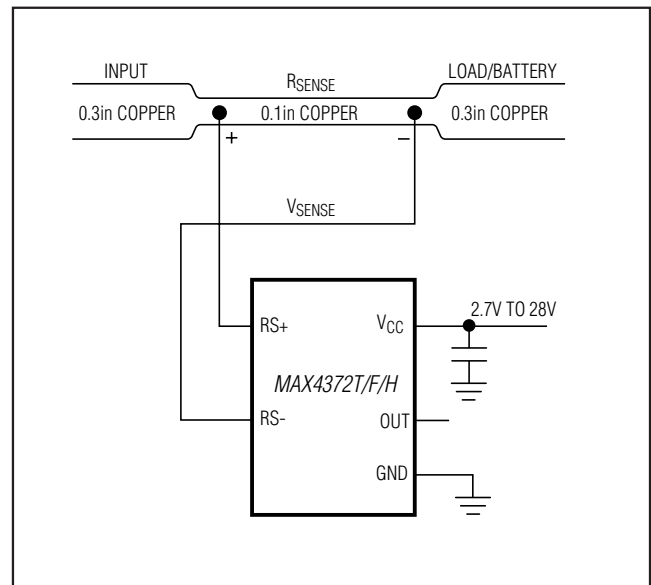

Figure 2. Connections Showing Use of PC Board

# MAX4372T/F/H

## Low-Cost, UCSP/SOT23, Micropower, High-Side Current-Sense Amplifier with Voltage Output <sup>d</sup>

### Ordering Information (continued)

| PART          | TEMP RANGE     | PIN-PACKAGE | TOP MARK |
|---------------|----------------|-------------|----------|
| MAX4372FEUK+T | -40°C to +85°C | 5 SOT23-5   | ADIV     |
| MAX4372FESA+T | -40°C to +85°C | 8 SO        | —        |
| MAX4372FEBT+T | -40°C to +85°C | 3 x 2 UCSP  | ACY      |
| MAX4372HEUK+T | -40°C to +85°C | 5 SOT23-5   | ADIW     |
| MAX4372HESA+T | -40°C to +85°C | 8 SO        | —        |
| MAX4372HEBT+T | -40°C to +85°C | 3 x 2 UCSP  | ACZ      |

+ Denotes a lead(Pb)-free/RoHS-compliant package.  
T = Tape and reel.

### Pin Configurations (continued)

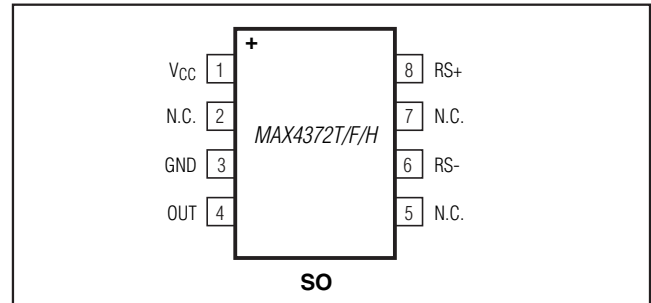

### Chip Information

PROCESS: BiCMOS

### Package Information

For the latest package outline information and land patterns, go to [www.maxim-ic.com/packages](http://www.maxim-ic.com/packages). Note that a "+", "#", or "-" in the package code indicates RoHS status only. Package drawings may show a different suffix character, but the drawing pertains to the package regardless of RoHS status.

| PACKAGE TYPE | PACKAGE CODE | OUTLINE NO.             | LAND PATTERN NO.        |
|--------------|--------------|-------------------------|-------------------------|
| 5 SOT23      | U5+1         | <a href="#">21-0057</a> | <a href="#">90-0174</a> |
| 8 SO         | S8+2         | <a href="#">21-0041</a> | <a href="#">90-0096</a> |
| 5 UCSP       | B6+2         | <a href="#">21-0097</a> | —                       |

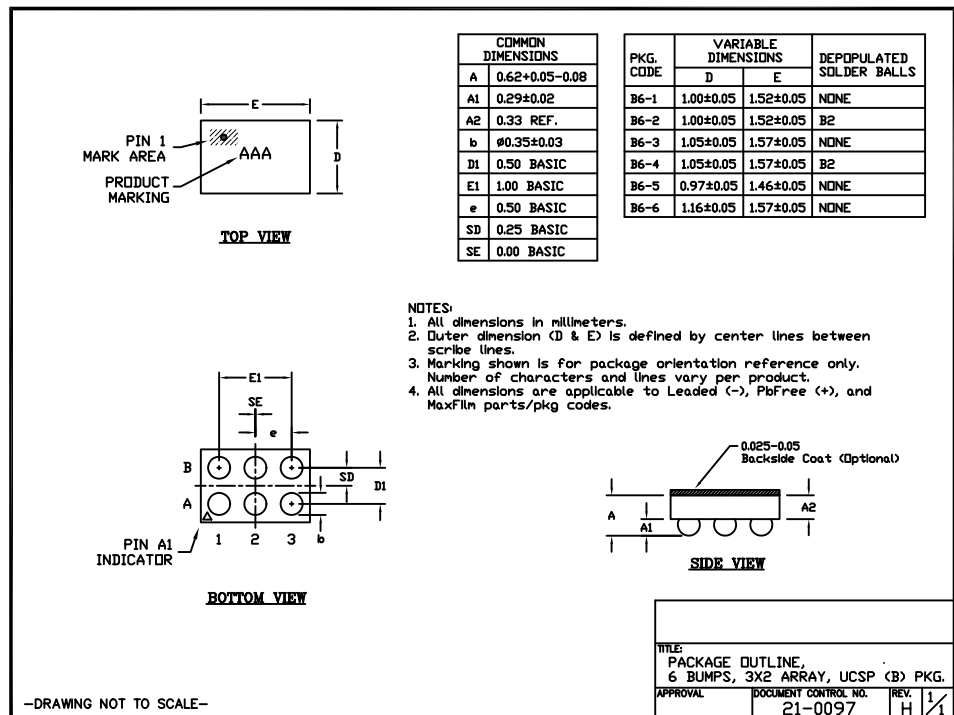

Note: MAX4372\_EBT uses package code B6-2.

# MAX4372T/F/H

## Low-Cost, UCSP/SOT23, Micropower, High-Side Current-Sense Amplifier with Voltage Output

### Package Information (continued)

For the latest package outline information and land patterns, go to [www.maxim-ic.com/packages](http://www.maxim-ic.com/packages). Note that a "+", "#", or "-" in the package code indicates RoHS status only. Package drawings may show a different suffix character, but the drawing pertains to the package regardless of RoHS status.

TOP VIEW

END VIEW

| COMMON DIMENSIONS |          |      |          |      |
|-------------------|----------|------|----------|------|
| SYMBOL            | INCHES   |      | MM       |      |
|                   | MIN.     | MAX. | MIN.     | MAX. |
| A                 | .053     | .069 | 1.35     | 1.75 |
| A1                | .004     | .010 | 0.10     | 0.25 |
| b                 | .014     | .019 | 0.35     | 0.49 |
| c                 | .007     | .010 | 0.19     | 0.25 |
| E                 | .150     | .157 | 3.80     | 4.00 |
| e                 | .050 BSC |      | 1.27 BSC |      |
| H                 | .228     | .244 | 5.80     | 6.20 |
| L                 | .016     | .050 | 0.40     | 1.27 |
| alpha             | 0°       | 8°   | 0°       | 8°   |

SIDE VIEW

| VARIATION A |                                                               |      |      |      |
|-------------|---------------------------------------------------------------|------|------|------|
| SYMBOL      | INCHES                                                        |      | MM   |      |
|             | MIN.                                                          | MAX. | MIN. | MAX. |
| D           | .189                                                          | .197 | 4.80 | 5.00 |
| N           | 8                                                             |      |      |      |
| MS012       | AA                                                            |      |      |      |
| PKG. CODE   | S8-2, S8-4, S8-5, S8-6F, S8-7F, S8-8F, S8-10F, S8-11F, S8-16F |      |      |      |

| VARIATION B |                                                            |      |      |      |
|-------------|------------------------------------------------------------|------|------|------|
| SYMBOL      | INCHES                                                     |      | MM   |      |
|             | MIN.                                                       | MAX. | MIN. | MAX. |
| D           | .337                                                       | .344 | 8.55 | 8.75 |
| N           | 14                                                         |      |      |      |
| MS012       | AB                                                         |      |      |      |
| PKG. CODE   | S14-1, S14-4, S14-5, S14-6, S14M-4, S14M-5, S14M-6, S14M-7 |      |      |      |

| VARIATION C |                                                                            |      |      |       |
|-------------|----------------------------------------------------------------------------|------|------|-------|
| SYMBOL      | INCHES                                                                     |      | MM   |       |
|             | MIN.                                                                       | MAX. | MIN. | MAX.  |
| D           | .386                                                                       | .394 | 9.80 | 10.00 |
| N           | 16                                                                         |      |      |       |
| MS012       | AC                                                                         |      |      |       |
| PKG. CODE   | S16-1, S16-3, S16-5, S16-6, S16-8, S16-7F, S16-9F, S16-10F, S16M-3, S16M-6 |      |      |       |

NOTES:

- ALL DIMENSIONS ARE IN MILLIMETERS UNLESS OTHERWISE SPECIFIED.
- MATERIAL MUST COMPLY WITH BANNED AND RESTRICTED SUBSTANCES SPEC # 10-0131.
- DIMENSIONS D AND E DO NOT INCLUDE MOLD PROTRUSION. ALLOWABLE MOLD PROTRUSION IS 0.15 MM (.006") PER SIDE.
- LEADS TO BE COPLANAR WITHIN 0.10mm (.004").
- MEETS JEDEC MS012
- ALL DIMENSIONS APPLY TO BOTH LEADED (-) AND PbFREE (+) PKG. CODES.

-DRAWING NOT TO SCALE-

TITLE:  
PACKAGE OUTLINE,  
8L, 14L, 16L SOIC .150 INCH

|          |                                 |           |     |
|----------|---------------------------------|-----------|-----|
| APPROVAL | DOCUMENT CONTROL NO.<br>21-0041 | REV.<br>C | 1/1 |
|----------|---------------------------------|-----------|-----|

SOICN LEPS

# MAX4372T/F/H

## Low-Cost, UCSP/SOT23, Micropower, High-Side Current-Sense Amplifier with Voltage Output

### Package Information (continued)

For the latest package outline information and land patterns, go to [www.maxim-ic.com/packages](http://www.maxim-ic.com/packages). Note that a "+", "#", or "-" in the package code indicates RoHS status only. Package drawings may show a different suffix character, but the drawing pertains to the package regardless of RoHS status.

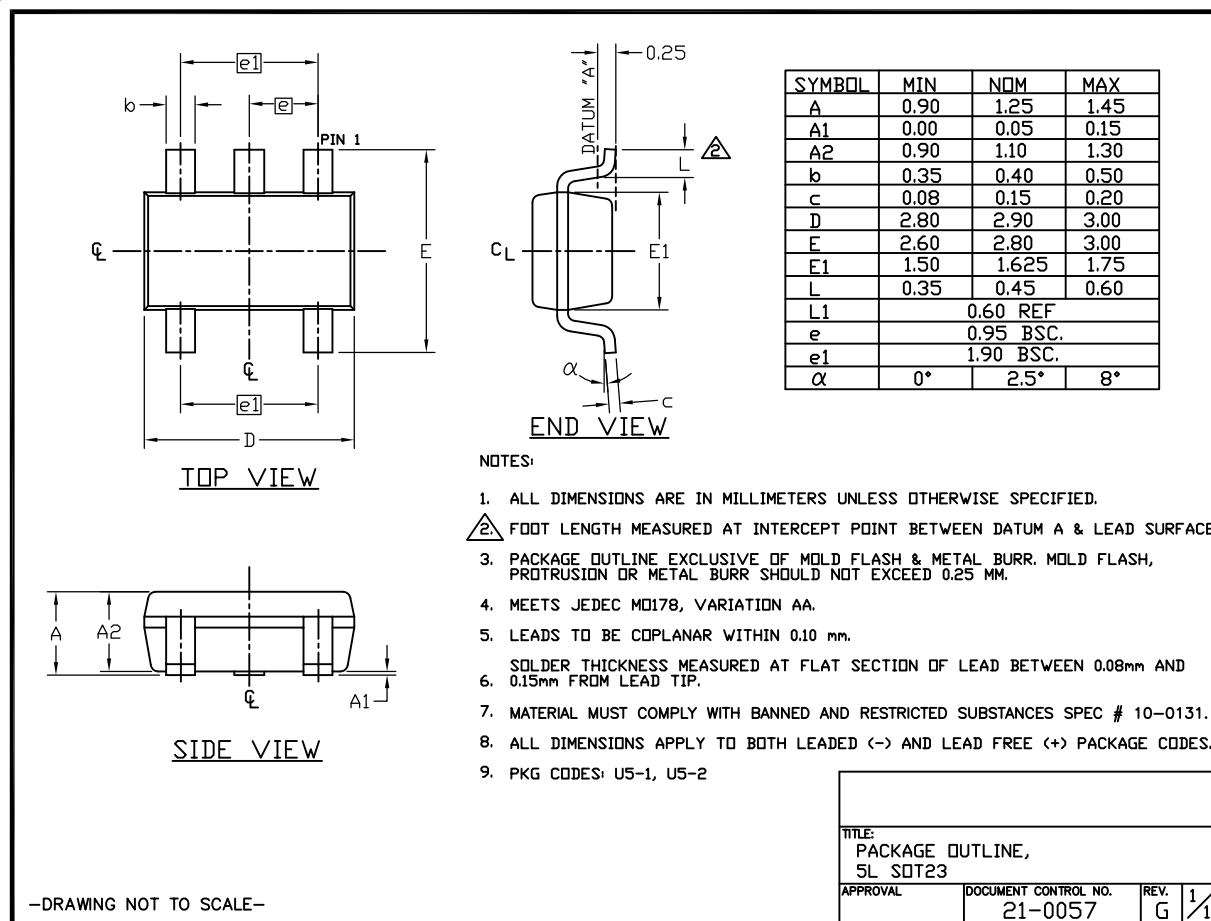

SOT-23 5L .EPS

# MAX4372T/F/H

## Low-Cost, UCSP/SOT23, Micropower, High-Side Current-Sense Amplifier with Voltage Output

### Revision History

| REVISION NUMBER | REVISION DATE | DESCRIPTION                                                                                 | PAGES CHANGED |
|-----------------|---------------|---------------------------------------------------------------------------------------------|---------------|
| 4               | 7/09          | Updated feature in accordance with actual performance of the product                        | 1             |
| 5               | 5/11          | Updated VRST conditions to synchronize with tested material and added lead-free designation | 1, 2, 3, 8    |



Maxim cannot assume responsibility for use of any circuitry other than circuitry entirely embodied in a Maxim product. No circuit patent licenses are implied. Maxim reserves the right to change the circuitry and specifications without notice at any time. The parametric values (min and max limits) shown in the Electrical Characteristics table are guaranteed. Other parametric values quoted in this data sheet are provided for guidance.

**Maxim Integrated 160 Rio Robles, San Jose, CA 95134 USA 1-408-601-1000**

11

# AMEYA360

## Components Supply Platform

Authorized Distribution Brand :



Website :

Welcome to visit [www.ameya360.com](http://www.ameya360.com)

Contact Us :

➤ Address :

401 Building No.5, JiuGe Business Center, Lane 2301, Yishan Rd  
Minhang District, Shanghai , China

➤ Sales :

Direct +86 (21) 6401-6692

Email [amall@ameya360.com](mailto:amall@ameya360.com)

QQ 800077892

Skype [ameyasales1](#) [ameyasales2](#)

➤ Customer Service :

Email [service@ameya360.com](mailto:service@ameya360.com)

➤ Partnership :

Tel +86 (21) 64016692-8333

Email [mkt@ameya360.com](mailto:mkt@ameya360.com)