

LM2757 Switched Capacitor Boost Regulator with High Impedance Output in Shutdown

Check for Samples: [LM2757](#)

FEATURES

- **Dual Gain Converter (2x, 3/2x) with up to 93% Efficiency.**
- **Inductorless Solution Uses Only 4 Small Ceramic Capacitors.**
- **Total Solution Area < 12mm².**
- **True Input-Output and Output-Input Disconnect.**
- **Up to 180 mA Output Current Capability (5V).**
- **Selectable 4.1V, 4.5V or 5.0V Output.**
- **Pre-Regulation Minimizes Input Current Ripple.**
- **1.24 MHz Switching Frequency for a Low-Noise, Low-Ripple Output Voltage.**
- **Integrated Over Current and Thermal Shutdown Protection.**
- **Tiny 1.2 mm X 1.6 mm X 0.4 mm Pitch, 12-Bump DSBGA Package.**

APPLICATIONS

- **USB/USB-OTG/HDMI Power**
- **Supercapacitor Charger**
- **Keypad LED Drive**
- **Audio Amplifier Power Supply**
- **Low-Current Camera Flash**
- **General Purpose Li-Ion-to-5V Conversion**
- **Cellular Phone SIM cards**

Typical Application Circuit

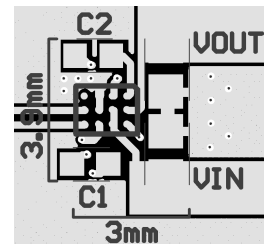
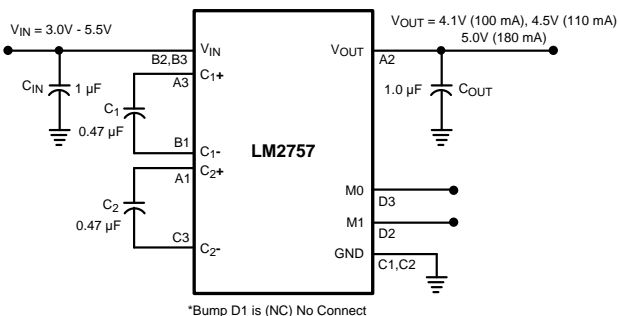

DESCRIPTION

The LM2757 is a constant frequency pre-regulated switched-capacitor charge pump that operates at 1.25 MHz to produce a low-noise regulated output voltage. The device can be configured to provide up to 100 mA at 4.1V, 110 mA at 4.5V, or 180 mA at 5V. Excellent efficiency is achieved without the use of an inductor by operating the charge pump in a gain of either 3/2 or 2 according to the input voltage and output voltage option selection.

The LM2757 presents a high impedance at the V_{OUT} pin when shut down. This allows for use in applications that require the regulated output bus to be driven by another supply while the LM2757 is shut down.

A perfect fit for space-constrained, battery-operated applications, the LM2757 requires only 4 small, inexpensive ceramic capacitors. LM2757 is a tiny 1.2 mm X 1.6 mm 12-bump DSBGA device. Built in soft-start, over-current protection, and thermal shutdown features are also included in this device.



Please be aware that an important notice concerning availability, standard warranty, and use in critical applications of Texas Instruments semiconductor products and disclaimers thereto appears at the end of this data sheet.

All trademarks are the property of their respective owners.

Connection Diagram

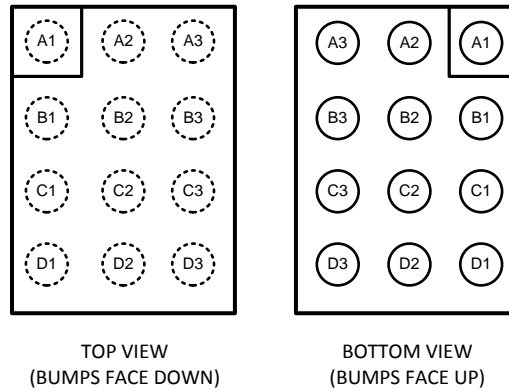

**Figure 1. 12-Bump DSBGA Package, 0.4mm Pitch
Package Number YFQ0012**

PIN DESCRIPTIONS

Pin #	Name	Description
A1	C2+	Flying Capacitor C2 Connection
A2	V _{OUT}	Regulated Output Voltage
A3	C1+	Flying Capacitor C1 Connection
B1	C1-	Flying Capacitor C1 Connection
B2	V _{IN}	Input Voltage Connection
B3	V _{IN}	Input Voltage Connection
C1	GND	Ground Connection
C2	GND	Ground Connection
C3	C2-	Flying Capacitor C2 Connection
D1	NC	No Connect — Do not connect this pin to any node, voltage or GND. Must be left floating.
D2	M1	Mode select pin 1
D3	M0	Mode select pin 0

Mode Selection Definition

M0	M1	Output Voltage Mode
0	0	Device Shutdown, Output High Impedance
0	1	5.0V
1	0	4.5V
1	1	4.1V



These devices have limited built-in ESD protection. The leads should be shorted together or the device placed in conductive foam during storage or handling to prevent electrostatic damage to the MOS gates.

Absolute Maximum Ratings ⁽¹⁾⁽²⁾⁽³⁾

V_{IN} Pin: Voltage to GND	-0.3V to 6.0V
M0, M1 pins: Voltage to GND	-0.3V to 6.0V
Continuous Power Dissipation ⁽⁴⁾	Internally Limited
Junction Temperature (T_{J-MAX})	150°C
Storage Temperature Range	-65°C to +150°C
Maximum Lead Temperature (Soldering, 10 sec.)	265°C
ESD Rating ⁽⁵⁾ Human Body Model:	2.5 kV

- (1) Absolute Maximum Ratings indicate limits beyond which damage to the component may occur. Operating Ratings are conditions under which operation of the device is ensured. Operating Ratings do not imply ensured performance limits. For ensured performance limits and associated test conditions, see the Electrical Characteristics tables.
- (2) If Military/Aerospace specified devices are required, please contact the TI Sales Office/ Distributors for availability and specifications.
- (3) All voltages are with respect to the potential at the GND pins.
- (4) Internal thermal shutdown circuitry protects the device from permanent damage. Thermal shutdown engages at $T_J=145^\circ\text{C}$ (typ.) and disengages at $T_J=135^\circ\text{C}$ (typ.).
- (5) The Human body model is a 100 pF capacitor discharged through a 1.5 k Ω resistor into each pin.

Operating Ratings ⁽¹⁾⁽²⁾

Input Voltage Range	2.7V to 5.5V
Junction Temperature (T_J) Range	-30°C to +110°C
Ambient Temperature (T_A) Range ⁽³⁾	-30°C to +85°C

- (1) Absolute Maximum Ratings indicate limits beyond which damage to the component may occur. Operating Ratings are conditions under which operation of the device is ensured. Operating Ratings do not imply ensured performance limits. For ensured performance limits and associated test conditions, see the Electrical Characteristics tables.
- (2) All voltages are with respect to the potential at the GND pins.
- (3) In applications where high power dissipation and/or poor package thermal resistance is present, the maximum ambient temperature may have to be derated. Maximum ambient temperature (T_{A-MAX}) is dependent on the maximum operating junction temperature ($T_{J-MAX-OP}=125^\circ\text{C}$), the maximum power dissipation of the device in the application (P_{D-MAX}), and the junction-to-ambient thermal resistance of the part/package in the application (θ_{JA}), as given by the following equation: $T_{A-MAX} = T_{J-MAX-OP} - (\theta_{JA} \times P_{D-MAX})$.

Thermal Properties

Junction-to-Ambient Thermal Resistance (θ_{JA}), DSBGA Package ⁽¹⁾	75°C/W
--	--------

- (1) Junction-to-ambient thermal resistance (θ_{JA}) is taken from a thermal modeling result, performed under the conditions and guidelines set forth in the JEDEC standard JESD51-7. The test board is a 4-layer FR-4 board measuring 102 mm x 76 mm x 1.6 mm with a 2x1 array of thermal vias. The ground plane on the board is 50 mm x 50 mm. Thickness of copper layers are 36 μm /18 μm /18 μm /36 μm (1.5 oz./1 oz./1 oz./1.5 oz.). Ambient temperature in simulation is 22°C, still air. Power dissipation is 1W. The value of θ_{JA} in LM2757 in DSBGA-12 could fall in a range as wide as 50°C/W to 150°C/W (if not wider), depending on PWB material, layout and environmental conditions. In applications where high maximum power dissipation exists (high V_{IN} , high I_{OUT}), special care must be paid to thermal dissipation issues. For more information on these topics, please refer to **Application Note 1112: Micro SMD Wafer Level Chip Scale Package (μSMD)**.

Electrical Characteristics

(1)(2)

Limits in standard typeface are for $T_A = 25^\circ\text{C}$. Limits in **boldface** type apply over the full operating ambient temperature range ($-30^\circ\text{C} \leq T_A \leq +85^\circ\text{C}$). Unless otherwise noted, specifications apply to the Typical Application Circuit (pg. 1) with: $V_{IN} = 3.6\text{V}$, $V(M0) = 0\text{V}$, $V(M1) = V_{IN}$, $C_{IN} = C_2 = 0.47\ \mu\text{F}$, $C_{IN} = C_{OUT} = 1.0\ \mu\text{F}$ ⁽³⁾.

Symbol	Parameter	Condition	Min	Typ	Max	Units
V_{OUT}	Output Voltage	$3.2\text{V} \leq V_{IN} \leq 5.5\text{V}$ $-30^\circ\text{C} \leq T_A \leq +60^\circ\text{C}$ $I_{OUT} = 0$ to 180 mA $V(M0) = 0\text{V}$, $V(M1) = V_{IN}$	4.870 (-2.6%)	5.0	5.130 (+2.6%)	V
		$3.0\text{V} \leq V_{IN} \leq 5.5\text{V}$ $-30^\circ\text{C} \leq T_A \leq +85^\circ\text{C}$ $I_{OUT} = 0$ to 150 mA $V(M0) = 0\text{V}$, $V(M1) = V_{IN}$	4.865 (-2.7%)	5.0	5.130 (+2.6%)	
		$3.0\text{V} \leq V_{IN} \leq 5.5\text{V}$ $I_{OUT} = 0$ to 110 mA $V(M0) = V_{IN}$, $V(M1) = 0\text{V}$	4.406 (-2.1%)	4.5	4.613 (+2.5%)	
		$3.0\text{V} \leq V_{IN} \leq 5.5\text{V}$ $I_{OUT} = 0$ to 100 mA $V(M0) = V_{IN}$, $V(M1) = V_{IN}$	3.985 (-2.8%)	4.1	4.223 (+3.0%)	
I_Q	Quiescent Supply Current	$V(M0) = 0\text{V}$, $V(M1) = V_{IN}$ (5.0V) $I_{OUT} = 0$ mA $V_{IN} = 3.6\text{V}$		2.4	2.79	mA
		$V(M0) = V_{IN}$, $V(M1) = 0\text{V}$ (4.5V) $I_{OUT} = 0$ mA $V_{IN} = 3.6\text{V}$		1.5	1.80	
		$V(M0) = V_{IN}$, $V(M1) = V_{IN}$ (4.1V) $I_{OUT} = 0$ mA $V_{IN} = 3.6\text{V}$		1.3	1.65	
I_{SD}	Shutdown Supply Current	$V(M0) = 0\text{V}$, $V(M1) = 0\text{V}$ $V_{IN} = 3.6\text{V}$		1.1	2.0	μA
V_R	Output Voltage Ripple	$I_{OUT} = 150$ mA $V(M0) = 0\text{V}$, $V(M1) = V_{IN}$ (5.0V) $3.0\text{V} \leq V_{IN} \leq 5.5\text{V}$		20		mVp-p
f_{SW}	Switching Frequency	$3.0\text{V} \leq V_{IN} \leq 5.5\text{V}$	0.932 (- 25%)	1.242	1.552 (+25%)	MHz
V_{IN}	Logic Input High	Input pins: M1, M0 $3.0\text{V} \leq V_{IN} \leq 5.5\text{V}$	1.0		V_{IN}	V
V_{IL}	Logic Input Low	Input pins: M1, M0 $3.0\text{V} \leq V_{IN} \leq 5.5\text{V}$	0		0.40	V
$R_{PULLDOWN}$	Logic Input Pulldown Resistance (M0, M1)	$V(M1, M0) = 5.5\text{V}$	324	457		k Ω
I_{IH}	Logic Input High Current	Input Pins: M1, M0 $V(M1, M0) = 1.8\text{V}$ ⁽⁴⁾		5		μA
I_{IL}	Logic Input Low Current	Input Pins: M1, M0 $V(M1, M0) = 0\text{V}$		10		nA
V_G	Gain Transition Voltage	1.5X to 2X, $V(M0) = V_{IN}$, $V(M1)=0\text{V}$		3.333		V
		2X to 1.5X, $V(M0) = V_{IN}$, $V(M1)=0\text{V}$		3.413		V
		Hysteresis, $V(M0) = V_{IN}$, $V(M1)=0\text{V}$		80		mV
		1.5X to 2X, $V(M0) = 0\text{V}$, $V(M1)=V_{IN}$		3.87		V
		2X to 1.5X, $V(M0) = 0\text{V}$, $V(M1)=V_{IN}$		3.93		V
		Hysteresis, $V(M0) = 0\text{V}$, $V(M1)=V_{IN}$		60		mV
I_{SC}	Short Circuit Output Current	$V_{OUT} = 0\text{V}$		250		mA

(1) All voltages are with respect to the potential at the GND pins.

(2) Min and Max limits are specified by design, test, or statistical analysis. Typical numbers are not ensured, but do represent the most likely norm.

(3) C_{IN} , C_{OUT} , C_1 , C_2 : Low-ESR Surface-Mount Ceramic Capacitors (MLCCs) used in setting electrical characteristics.

(4) There is a 450 k Ω (typ.) pull-down resistor connected internally to each logic input.

Electrical Characteristics (continued)

(1) (2)

Limits in standard typeface are for $T_A = 25^\circ\text{C}$. Limits in **boldface** type apply over the full operating ambient temperature range ($-30^\circ\text{C} \leq T_A \leq +85^\circ\text{C}$). Unless otherwise noted, specifications apply to the Typical Application Circuit (pg. 1) with: $V_{IN} = 3.6\text{V}$, $V(M0) = 0\text{V}$, $V(M1) = V_{IN}$, $C_{IN} = C_2 = 0.47\ \mu\text{F}$, $C_{IN} = C_{OUT} = 1.0\ \mu\text{F}$ ⁽³⁾.

Symbol	Parameter	Condition	Min	Typ	Max	Units
I_{ON}	V_{OUT} Turn-On Time from Shutdown ⁽⁵⁾			300		μs

(5) Turn-on time is measured from when the M0 or M1 signal is pulled high until the output voltage crosses 90% of its final value.

Block Diagram

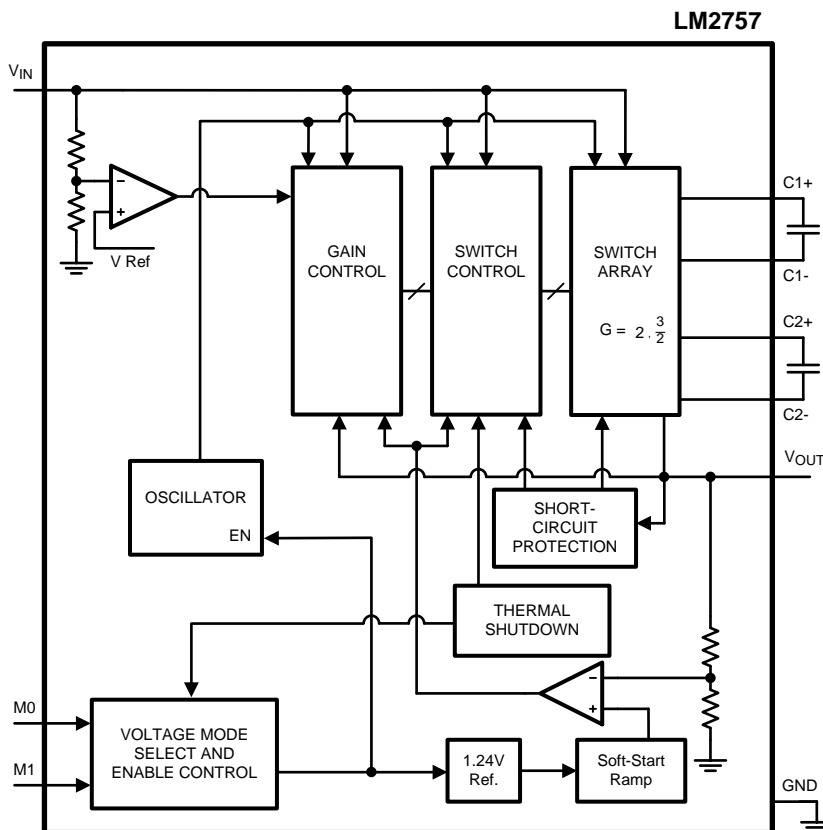

Typical Performance Characteristics

Unless otherwise specified: $V_{IN} = 3.6V$, $V(M0) = 0V$, $V(M1) = V_{IN}$, $C_1 = C_2 = 0.47\mu F$, $C_{IN} = C_{OUT} = 1.0\mu F$, $T_A = 25^\circ C$.
Capacitors are low-ESR multi-layer ceramic capacitors (MLCC's).

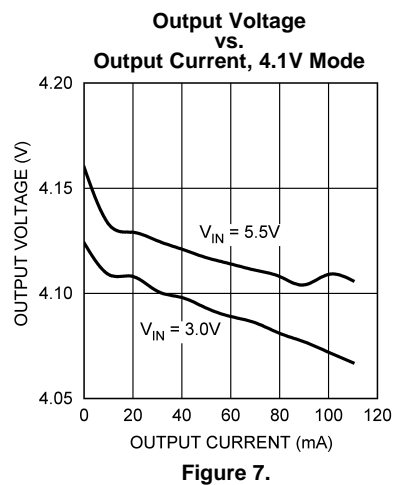
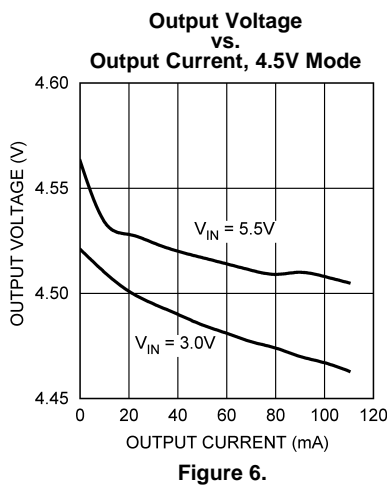
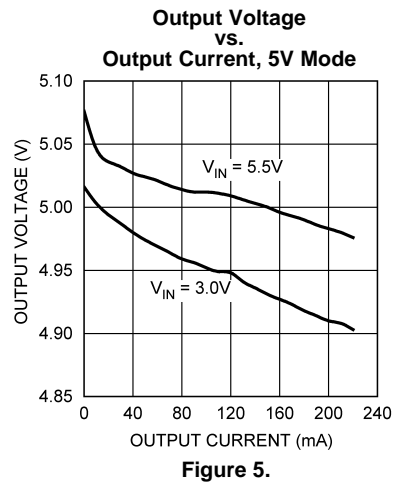
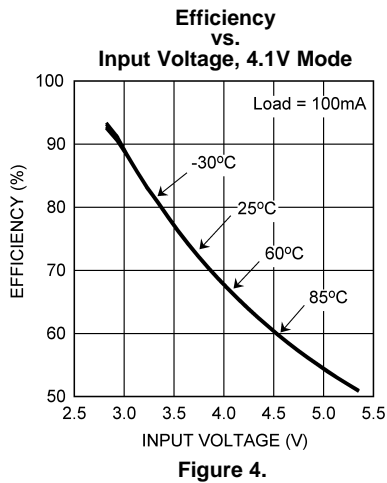
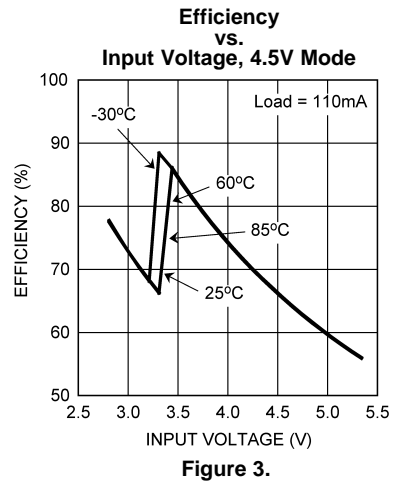
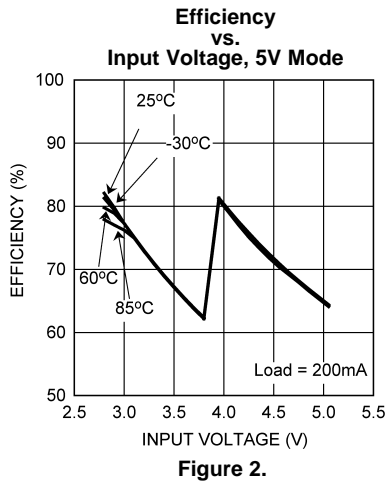

Typical Performance Characteristics (continued)

Unless otherwise specified: $V_{IN} = 3.6V$, $V(M0) = 0V$, $V(M1) = V_{IN}$, $C_1 = C_2 = 0.47\mu F$, $C_{IN} = C_{OUT} = 1.0\mu F$, $T_A = 25^\circ C$. Capacitors are low-ESR multi-layer ceramic capacitors (MLCC's).

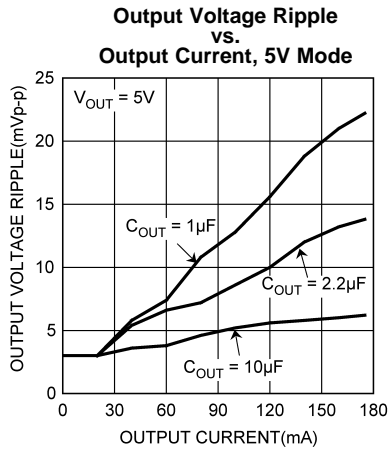

Figure 8.

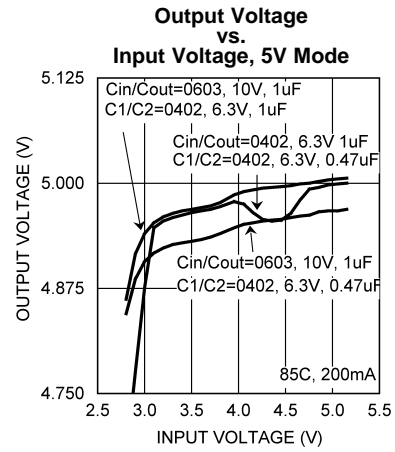

Figure 9.

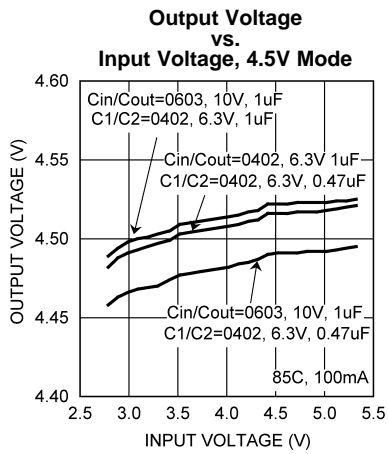

Figure 10.

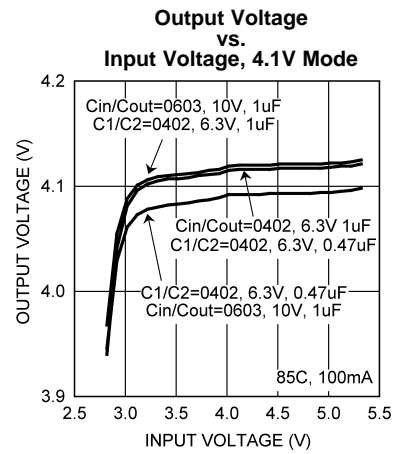

Figure 11.

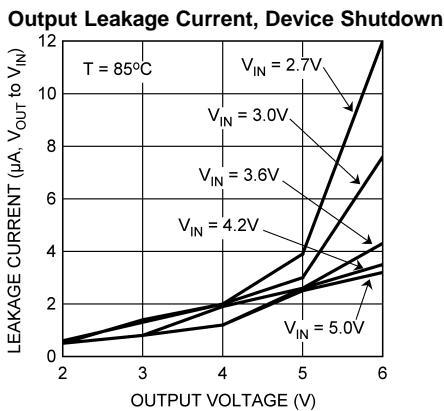

Figure 12.

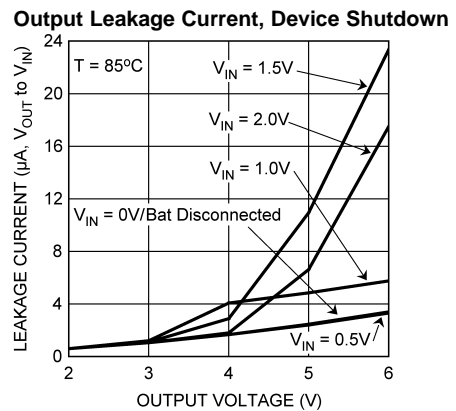

Figure 13.

Typical Performance Characteristics (continued)

Unless otherwise specified: $V_{IN} = 3.6V$, $V(M0) = 0V$, $V(M1) = V_{IN}$, $C_1 = C_2 = 0.47\mu F$, $C_{IN} = C_{OUT} = 1.0\mu F$, $T_A = 25^\circ C$. Capacitors are low-ESR multi-layer ceramic capacitors (MLCC's).

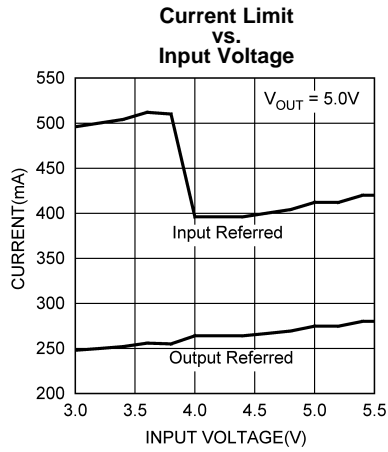

Figure 14.

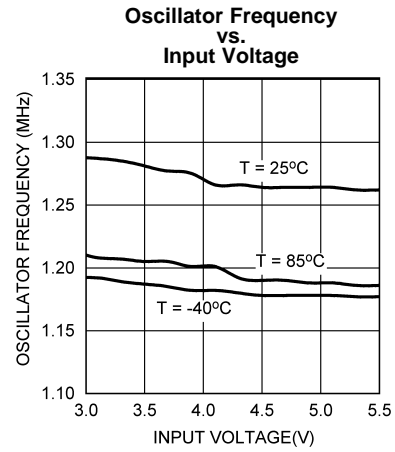

Figure 15.

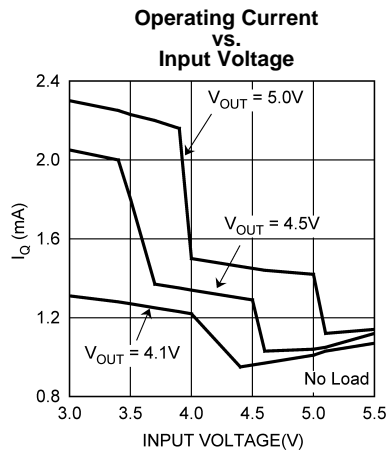

Figure 16.

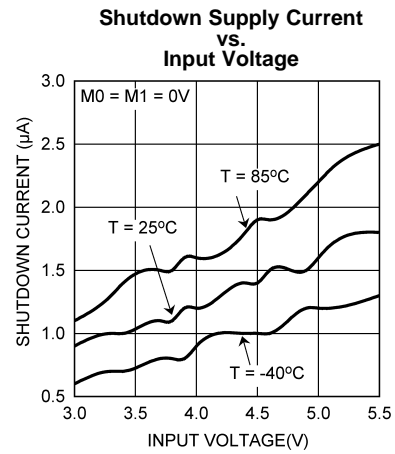

Figure 17.

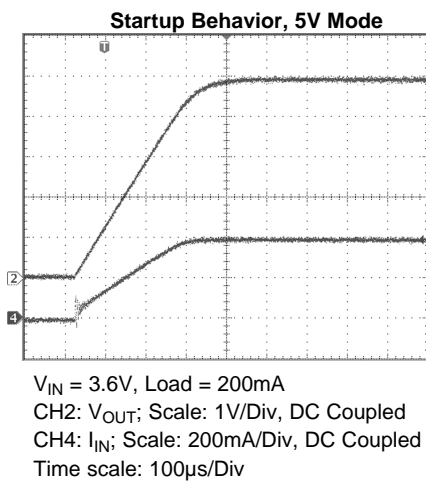

Figure 18.

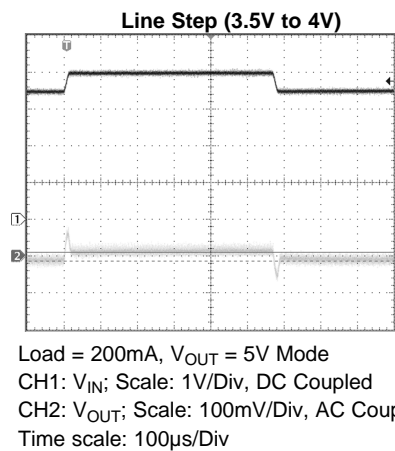
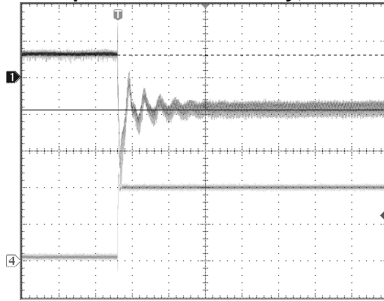

Figure 19.

Typical Performance Characteristics (continued)

Unless otherwise specified: $V_{IN} = 3.6V$, $V(M0) = 0V$, $V(M1) = V_{IN}$, $C_1 = C_2 = 0.47\mu F$, $C_{IN} = C_{OUT} = 1.0\mu F$, $T_A = 25^\circ C$.
Capacitors are low-ESR multi-layer ceramic capacitors (MLCC's).

Load Step with a Li-Ion Battery, 10mA to 200mA



$V_{BATT} = 4V$, $V_{OUT} = 5V$ Mode
CH1: V_{OUT} ; Scale: 50mV/Div, AC Coupled
CH4: I_{OUT} ; Scale: 100mA/Div, DC Coupled
Time scale: 10µs/Div

Figure 20.

Load Step with a Li-Ion Battery 200mA to 10mA

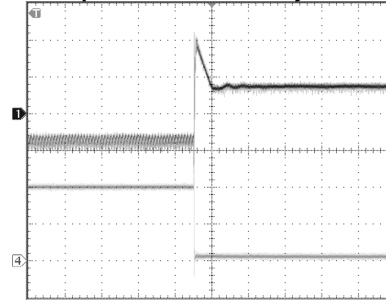

$V_{BATT} = 4V$, $V_{OUT} = 5V$ Mode
CH1: V_{OUT} ; Scale: 50mV/Div, AC Coupled
CH4: I_{OUT} ; Scale: 100mA/Div, DC Coupled
Time scale: 10µs/Div

Figure 21.

OPERATION DESCRIPTION

Overview

The LM2757 is a switched capacitor converter that produces a regulated output voltage of either 5V, 4.5V or 4.1V depending on the mode selected. The core of the part is a highly efficient charge pump that utilizes fixed frequency pre-regulation to minimize ripple and power losses over wide input voltage and output current ranges. A description of the principal operational characteristics of the LM2757 is detailed in the [Circuit Description](#) and [Efficiency Performance](#) sections. These sections refer to details in the [Block Diagram](#).

Circuit Description

The core of the LM2757 is a two-phase charge pump controlled by an internally generated non-overlapping clock. The charge pump operates by using external flying capacitors C_1 , C_2 to transfer charge from the input to the output. At input voltages below 3.9V (typ.) for the 5V mode, the LM2757 operates in a 2x gain, with the input current being equal to 2x the load current. At input voltages above 3.9V (typ.) for the 5V mode, the part utilizes a gain of 3/2x, resulting in an input current equal to 3/2 times the load current. For the 4.5V mode, the LM2757 operates in a 2x gain when the input voltage is below 3.35V (typ.) and transitions to a 3/2x gain when the input voltage is above 3.35V (typ.). For the 4.1V mode, the device utilizes the 3/2x gain for the entire input voltage range.

The two phases of the switched capacitor switching cycle will be referred to as the "phase one" and the "phase two". During phase one, one flying capacitor is charged by the input supply while the other flying capacitor is connected to the output and delivers charge to the load. After half of the switching cycle [$t = 1/(2 \times F_{SW})$], the LM2757 switches to phase two. In this configuration, the capacitor that supplied charge to the load in phase one is connected to the input to be recharged while the capacitor that had been charged in the previous phase is connected to the output to deliver charge. With this topology, output ripple is reduced by delivering charge to the output in every phase.

The LM2757 uses fixed frequency pre-regulation to regulate the output voltage. The input and output connections of the flying capacitors are made with internal MOS switches. Pre-regulation limits the gate drive of the MOS switch connected between the voltage input and the flying capacitors. Controlling the on resistance of this switch limits the amount of charge transferred into and out of each flying capacitor during the charge and discharge phases, and in turn helps to keep the output ripple very low.

Efficiency Performance

Charge-pump efficiency is derived in the following two ideal equations (supply current and other losses are neglected for simplicity):

$$I_{IN} = G \times I_{OUT}$$

$$E = (V_{OUT} \times I_{OUT}) \div (V_{IN} \times I_{IN}) = V_{OUT} \div (G \times V_{IN})$$

In the equations, G represents the charge pump gain. Efficiency is at its highest as $G \times V_{IN}$ approaches V_{OUT} . Refer to the efficiency graph in the [Typical Performance Characteristics](#) section for detailed efficiency data. The transition between gains of 3/2, and 2 are clearly distinguished by the sharp discontinuity in the efficiency curve.

Enable and Voltage Mode Selection

The LM2757 is enabled when either one of the mode select pins (M0, M1) has a logic High voltage applied to it. There are 450kΩ pulldown resistors connected internally to each of the mode select pins. The voltage mode is selected according to the following table.

M0	M1	Output Voltage Mode
0	0	Device Shutdown, Output High Impedance
0	1	5V
1	0	4.5V
1	1	4.1V

Shutdown with Output High Impedance

The LM2757 is in shutdown mode when there is a logic Low voltage on both mode select pins (M0, M1). There are also 450k Ω pulldown resistors connected to both mode select pins, pulling the nodes down to ground when there is no signal present. When in shutdown, the output of the LM2757 is high impedance, allowing an external supply to drive the output line such as in USB OTG or mobile HDMI applications. Refer to the output leakage current graphs in the [Typical Performance Characteristics](#) section for typical leakage currents into the V_{OUT} pin, when driven by a separate supply during shutdown. Output leakage increases with temperature, with the lowest leakage occurring at -30°C and the highest leakage at 85°C (on which the graph is based). It should be noted when looking at the graphs, as the input voltage falls the leakage peaks at around an input voltage of 1.5V, and then goes down as the input voltage goes to 0V. The leakage at an input voltage of 0V is the same as the leakage current when the battery is disconnected from the circuit.

Soft Start

The LM2757 employs soft start circuitry to prevent excessive input inrush currents during startup. At startup, the output voltage gradually rises from 0V to the nominal output voltage. This occurs in 300 μ s (typ.). Soft-start is engaged when the part is enabled.

Thermal Shutdown

Protection from damage related to overheating is achieved with a thermal shutdown feature. When the junction temperature rises to 145°C (typ.), the part switches into shutdown mode. The LM2757 disengages thermal shutdown when the junction temperature of the part is reduced to 135°C (typ.). Due to the high efficiency of the LM2757, thermal shutdown and/or thermal cycling should not be encountered when the part is operated within specified input voltage, output current, and ambient temperature operating ratings. If thermal cycling is seen under these conditions, the most likely cause is an inadequate PCB layout that does not allow heat to be sufficiently dissipated out of the device.

Current Limit Protection

The LM2757 charge pump contains current limit protection circuitry that protects the device during V_{OUT} fault conditions where excessive current is drawn. Output current is limited to 250mA (typ.).

Application Information

Recommended Capacitor Types

The LM2757 requires 4 external capacitors for proper operation. Surface-mount multi-layer ceramic capacitors are recommended. These capacitors are small, inexpensive and have very low equivalent series resistance (ESR, \leq 15m Ω typ.). Tantalum capacitors, OS-CON capacitors, and aluminum electrolytic capacitors generally are not recommended for use with the LM2757 due to their high ESR, as compared to ceramic capacitors.

For most applications, ceramic capacitors with an X7R or X5R temperature characteristic are preferred for use with the LM2757. These capacitors have tight capacitance tolerance (as good as \pm 10%) and hold their value over temperature (X7R: \pm 15% over -55°C to 125°C; X5R: \pm 15% over -55°C to 85°C).

Capacitors with a Y5V or Z5U temperature characteristic are generally not recommended for use with the LM2757. These types of capacitors typically have wide capacitance tolerance (+80%, -20%) and vary significantly over temperature (Y5V: +22%, -82% over -30°C to +85°C range; Z5U: +22%, -56% over +10°C to +85°C range). Under some conditions, a 1 μ F-rated Y5V or Z5U capacitor could have a capacitance as low as 0.1 μ F. Such detrimental deviation is likely to cause Y5V and Z5U capacitors to fail to meet the minimum capacitance requirements of the LM2757.

Net capacitance of a ceramic capacitor decreases with increased DC bias. This degradation can result in lower capacitance than expected on the input and/or output, resulting in higher ripple voltages and currents. Using capacitors at DC bias voltages significantly below the capacitor voltage rating will usually minimize DC bias effects. Consult capacitor manufacturers for information on capacitor DC bias characteristics.

Capacitance characteristics can vary quite dramatically with different application conditions, capacitor types, and capacitor manufacturers. It is strongly recommended that the LM2757 circuit be thoroughly evaluated early in the design-in process with the mass-production capacitors of choice. This will help ensure that any such variability in capacitance does not negatively impact circuit performance.

The voltage rating of the output capacitor should be 10V or more. For example, a 10V 0603 1.0 μ F is acceptable for use with the LM2757, as long as the capacitance does not fall below a minimum of 0.5 μ F in the intended application. All other capacitors should have a voltage rating at or above the maximum input voltage of the application. The capacitors should be selected such that the capacitance on the input does not fall below 0.7 μ F, and the capacitance of the flying capacitors does not fall below 0.2 μ F.

The table below lists some leading ceramic capacitor manufacturers.

Manufacturer	Contact Information
AVX	www.avx.com
Murata	www.murata.com
Taiyo-Yuden	www.t-yuden.com
TDK	www.component.tdk.com
Vishay-Vitramon	www.vishay.com

Output Capacitor and Output Voltage Ripple

The output capacitor in the LM2757 circuit (C_{OUT}) directly impacts the magnitude of output voltage ripple. Other prominent factors also affecting output voltage ripple include input voltage, output current and flying capacitance. Due to the complexity of the regulation topology, providing equations or models to approximate the magnitude of the ripple can not be easily accomplished. But one important generalization can be made: increasing (decreasing) the output capacitance will result in a proportional decrease (increase) in output voltage ripple.

In typical high-current applications, a 1.0 μ F low-ESR ceramic output capacitor is recommended. Different output capacitance values can be used to reduce ripple, shrink the solution size, and/or cut the cost of the solution. But changing the output capacitor may also require changing the flying capacitor and/or input capacitor to maintain good overall circuit performance. Performance of the LM2757 with different capacitor setups is discussed in the section [Recommended Capacitance](#).

High ESR in the output capacitor increases output voltage ripple. If a ceramic capacitor is used at the output, this is usually not a concern because the ESR of a ceramic capacitor is typically very low and has only a minimal impact on ripple magnitudes. If a different capacitor type with higher ESR is used (tantalum, for example), the ESR could result in high ripple. To eliminate this effect, the net output ESR can be significantly reduced by placing a low-ESR ceramic capacitor in parallel with the primary output capacitor. The low ESR of the ceramic capacitor will be in parallel with the higher ESR, resulting in a low net ESR based on the principles of parallel resistance reduction.

Input Capacitor and Input Voltage Ripple

The input capacitor (C_{IN}) is a reservoir of charge that aids a quick transfer of charge from the supply to the flying capacitors during the charge phase of operation. The input capacitor helps to keep the input voltage from drooping at the start of the charge phase when the flying capacitors are connected to the input. It also filters noise on the input pin, keeping this noise out of sensitive internal analog circuitry that is biased off the input line.

Much like the relationship between the output capacitance and output voltage ripple, input capacitance has a dominant and first-order effect on input ripple magnitude. Increasing (decreasing) the input capacitance will result in a proportional decrease (increase) in input voltage ripple. Input voltage, output current, and flying capacitance also will affect input ripple levels to some degree.

In typical high-current applications, a 1.0 μ F low-ESR ceramic capacitor is recommended on the input. Different input capacitance values can be used to reduce ripple, shrink the solution size, and/or cut the cost of the solution. But changing the input capacitor may also require changing the flying capacitor and/or output capacitor to maintain good overall circuit performance. Performance of the LM2757 with different capacitor setups is discussed below in [Recommended Capacitance](#).

Flying Capacitors

The flying capacitors (C_1 , C_2) transfer charge from the input to the output. Flying capacitance can impact both output current capability and ripple magnitudes. If flying capacitance is too small, the LM2757 may not be able to regulate the output voltage when load currents are high. On the other hand, if the flying capacitance is too large, the flying capacitor might overwhelm the input and output capacitors, resulting in increased input and output ripple.

In typical high-current applications, 0.47 μ F low-ESR ceramic capacitors are recommended for the flying capacitors. Polarized capacitors (tantalum, aluminum electrolytic, etc.) must not be used for the flying capacitor, as they could become reverse-biased during LM2757 operation.

Recommended Capacitance

The data in [Table 1](#) can be used to assist in the selection of capacitance for each node that best balances solution size and cost with the electrical requirements of the application.

As previously discussed, input and output ripple voltages will vary with output current and input voltage. The numbers provided show expected ripple voltage with $V_{IN} = 3.6V$ and a load current of 200mA at 5V output, 100mA at 4.5V output, and 100mA at 4.1V output. The table offers a first look at approximate ripple levels and provides a comparison of different capacitance configurations, but is not intended to ensure performance. With any capacitance configuration chosen, always verify that the performance of the ripple waveforms are suitable for the intended application. The same capacitance value must be used for all the flying capacitors. For output regulation performance with different capacitor configurations, please refer to the Output Voltage vs. Input Voltage graphs in the [Typical Performance Characteristics](#) section of this datasheet. The output voltage regulation is typically better when using capacitors with a higher capacitance value and a higher voltage bias rating than the nominal voltage applied to them, as can be seen in the graphs, but this may have an impact in capacitor case size. For typical high-current small solution size applications, 1 μ F capacitance X5R temperature characteristic rating 0402 (C1005) case size and 10V bias or higher capacitors can be used for the Input, Output and Flying capacitors. According to current capacitor offerings, there are no capacitors in the 0201 (C0603) case size that satisfy the minimum capacitance requirements of the LM2757 circuit. When selecting capacitors, it is preferred to use the ones with the highest voltage bias rating available from the capacitor supplier.

Table 1. LM2757 Performance with Different Capacitor Configurations ⁽¹⁾

Capacitor Configuration ($V_{IN} = 3.6V$)	Typical 5.0V, 200mA Output Ripple	Typical 4.5V, 100mA Output Ripple	Typical 4.1V, 100mA Output Ripple
$C_{IN} = 1\mu F$, $C_{OUT} = 1\mu F$, $C_1, C_2 = 0.47\mu F$	32mV	12mV	11mV
$C_{IN} = 0.68\mu F$, $C_{OUT} = 1\mu F$, $C_1, C_2 = 0.47\mu F$	32mV	11mV	11mV
$C_{IN} = 0.68\mu F$, $C_{OUT} = 0.47\mu F$, $C_1, C_2 = 0.47\mu F$	51mV	15mV	15mV
$C_{IN} = 0.68\mu F$, $C_{OUT} = 0.47\mu F$, $C_1, C_2 = 0.22\mu F$	53mV	18mV	18mV

(1) Refer to the text in the [Recommended Capacitance](#) section for detailed information on the data in this table

Layout Guidelines

Proper board layout will help to ensure optimal performance of the LM2757 circuit. The following guidelines are recommended:

- Place capacitors as close to the LM2757 as possible, and preferably on the same side of the board as the IC.
- Use short, wide traces to connect the external capacitors to the LM2757 to minimize trace resistance and inductance.
- Use a low resistance connection between ground and the GND pin of the LM2757. Using wide traces and/or multiple vias to connect GND to a ground plane on the board is most advantageous.

Application Circuits

USB OTG / Mobile HDMI Power Supply

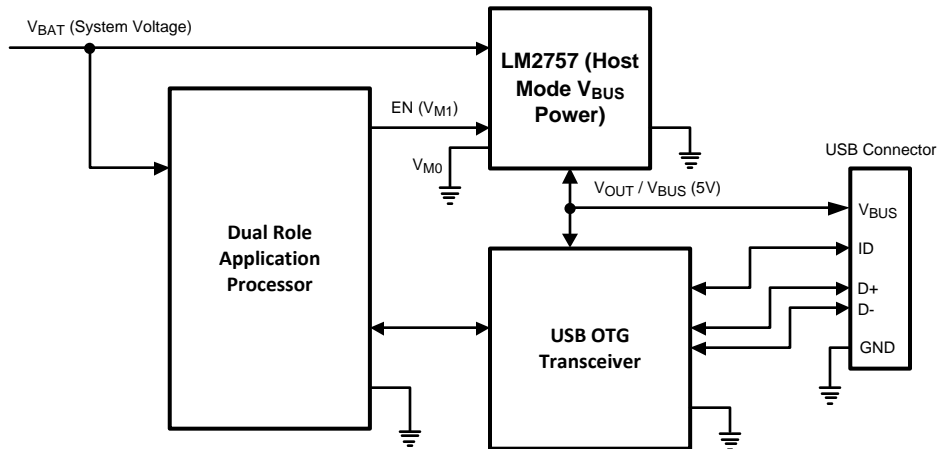

The 5V output mode will normally be used for the USB OTG / Mobile HDMI application. Therefore the LM2757 can be enabled/disabled by applying a logic signal on only the M1 pin while grounding the M0 pin. Depending on the USB/HDMI mode of the application, the LM2757 can be enabled to drive the power bus line (Host), or disabled to put its output in high impedance allowing an external supply to drive the bus line (Slave). In addition to the high impedance-backdrive protection, the output current limit protection is 250mA (typ.), well within the USB OTG and HDMI requirements.

Supercapacitor Flash Driver

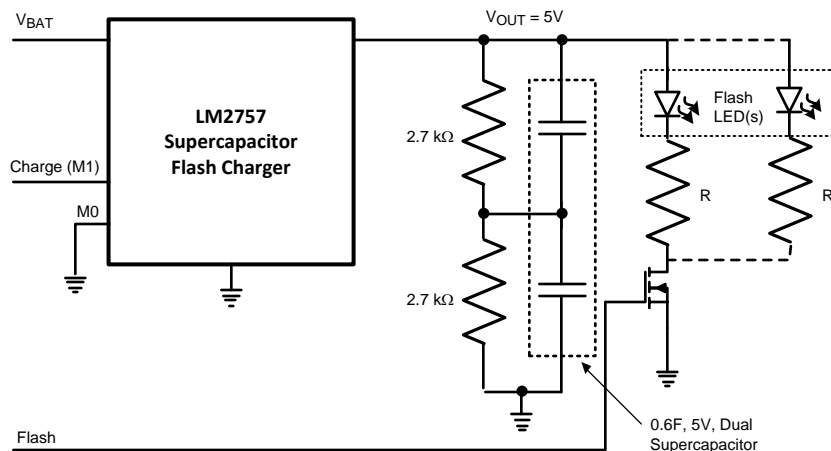

Using the 5V output voltage mode, the LM2757 can be used to charge a Supercapacitor for LED Flash applications while limiting the peak current drawn off the battery during the charge cycle. The LM2757 can be disabled for the Flash event, placing its output in high impedance with the input. In this way, all charge for the Flash LED(s) will come directly off the Supercapacitor and not load the main battery line. The LM2757 can be enabled/disabled by applying a logic signal on only the M1 pin while grounding the M0 pin.

Special consideration must be taken when using Supercapacitors for LED flash applications where the voltage on the capacitor is charged to a fixed value. This is due to the possible power management issues that could arise as a result of the high flash current and wide tolerance ranges ($V-I$ characteristics) of typical Flash LEDs. If the voltage across the Flash LED(s) is not managed, damage could occur where a relatively low V_f LED is overdriven or places excessive voltage across the bottom control FET. To help reduce this issue, the use of a high power current sink is advised in applications where the forward voltage specification of the Flash LED has a wide range.

LED Driver

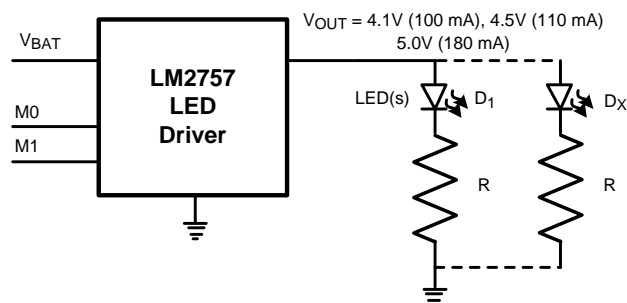

The 5.0V, 4.5V, or the 4.1V mode can be used depending on the forward voltage and load requirements of the LED application. The LM2757 can be enabled/disabled by applying the appropriate combination of logic signals on the M1 and M0 pins. LED current for each string in this application is limited by the voltage across the string's ballast resistor, which is dependent on the output voltage mode selected and the V-I profile of each LED used.

REVISION HISTORY

Changes from Revision D (May 2013) to Revision E	Page
• Changed layout of National Data Sheet to TI format	15

PACKAGING INFORMATION

Orderable Device	Status (1)	Package Type	Package Drawing	Pins	Package Qty	Eco Plan (2)	Lead/Ball Finish	MSL Peak Temp (3)	Op Temp (°C)	Top-Side Markings (4)	Samples
LM2757TM/NOPB	ACTIVE	DSBGA	YFQ	12	250	Green (RoHS & no Sb/Br)	SNAGCU	Level-1-260C-UNLIM	-30 to 85	DL	Samples
LM2757TMX/NOPB	ACTIVE	DSBGA	YFQ	12	3000	Green (RoHS & no Sb/Br)	SNAGCU	Level-1-260C-UNLIM	-30 to 85	DL	Samples

(1) The marketing status values are defined as follows:

ACTIVE: Product device recommended for new designs.

LIFEBUY: TI has announced that the device will be discontinued, and a lifetime-buy period is in effect.

NRND: Not recommended for new designs. Device is in production to support existing customers, but TI does not recommend using this part in a new design.

PREVIEW: Device has been announced but is not in production. Samples may or may not be available.

OBSOLETE: TI has discontinued the production of the device.

(2) Eco Plan - The planned eco-friendly classification: Pb-Free (RoHS), Pb-Free (RoHS Exempt), or Green (RoHS & no Sb/Br) - please check <http://www.ti.com/productcontent> for the latest availability information and additional product content details.

TBD: The Pb-Free/Green conversion plan has not been defined.

Pb-Free (RoHS): TI's terms "Lead-Free" or "Pb-Free" mean semiconductor products that are compatible with the current RoHS requirements for all 6 substances, including the requirement that lead not exceed 0.1% by weight in homogeneous materials. Where designed to be soldered at high temperatures, TI Pb-Free products are suitable for use in specified lead-free processes.

Pb-Free (RoHS Exempt): This component has a RoHS exemption for either 1) lead-based flip-chip solder bumps used between the die and package, or 2) lead-based die adhesive used between the die and leadframe. The component is otherwise considered Pb-Free (RoHS compatible) as defined above.

Green (RoHS & no Sb/Br): TI defines "Green" to mean Pb-Free (RoHS compatible), and free of Bromine (Br) and Antimony (Sb) based flame retardants (Br or Sb do not exceed 0.1% by weight in homogeneous material)

(3) MSL, Peak Temp. -- The Moisture Sensitivity Level rating according to the JEDEC industry standard classifications, and peak solder temperature.

(4) Multiple Top-Side Markings will be inside parentheses. Only one Top-Side Marking contained in parentheses and separated by a "~" will appear on a device. If a line is indented then it is a continuation of the previous line and the two combined represent the entire Top-Side Marking for that device.

Important Information and Disclaimer: The information provided on this page represents TI's knowledge and belief as of the date that it is provided. TI bases its knowledge and belief on information provided by third parties, and makes no representation or warranty as to the accuracy of such information. Efforts are underway to better integrate information from third parties. TI has taken and continues to take reasonable steps to provide representative and accurate information but may not have conducted destructive testing or chemical analysis on incoming materials and chemicals. TI and TI suppliers consider certain information to be proprietary, and thus CAS numbers and other limited information may not be available for release.

In no event shall TI's liability arising out of such information exceed the total purchase price of the TI part(s) at issue in this document sold by TI to Customer on an annual basis.

TAPE AND REEL INFORMATION



QUADRANT ASSIGNMENTS FOR PIN 1 ORIENTATION IN TAPE



*All dimensions are nominal

Device	Package Type	Package Drawing	Pins	SPQ	Reel Diameter (mm)	Reel Width W1 (mm)	A0 (mm)	B0 (mm)	K0 (mm)	P1 (mm)	W (mm)	Pin1 Quadrant
LM2757TM/NOPB	DSBGA	YFQ	12	250	178.0	8.4	1.35	1.75	0.76	4.0	8.0	Q1
LM2757TMX/NOPB	DSBGA	YFQ	12	3000	178.0	8.4	1.35	1.75	0.76	4.0	8.0	Q1

TAPE AND REEL BOX DIMENSIONS

*All dimensions are nominal

Device	Package Type	Package Drawing	Pins	SPQ	Length (mm)	Width (mm)	Height (mm)
LM2757TM/NOPB	DSBGA	YFQ	12	250	210.0	185.0	35.0
LM2757TMX/NOPB	DSBGA	YFQ	12	3000	210.0	185.0	35.0

YFQ0012

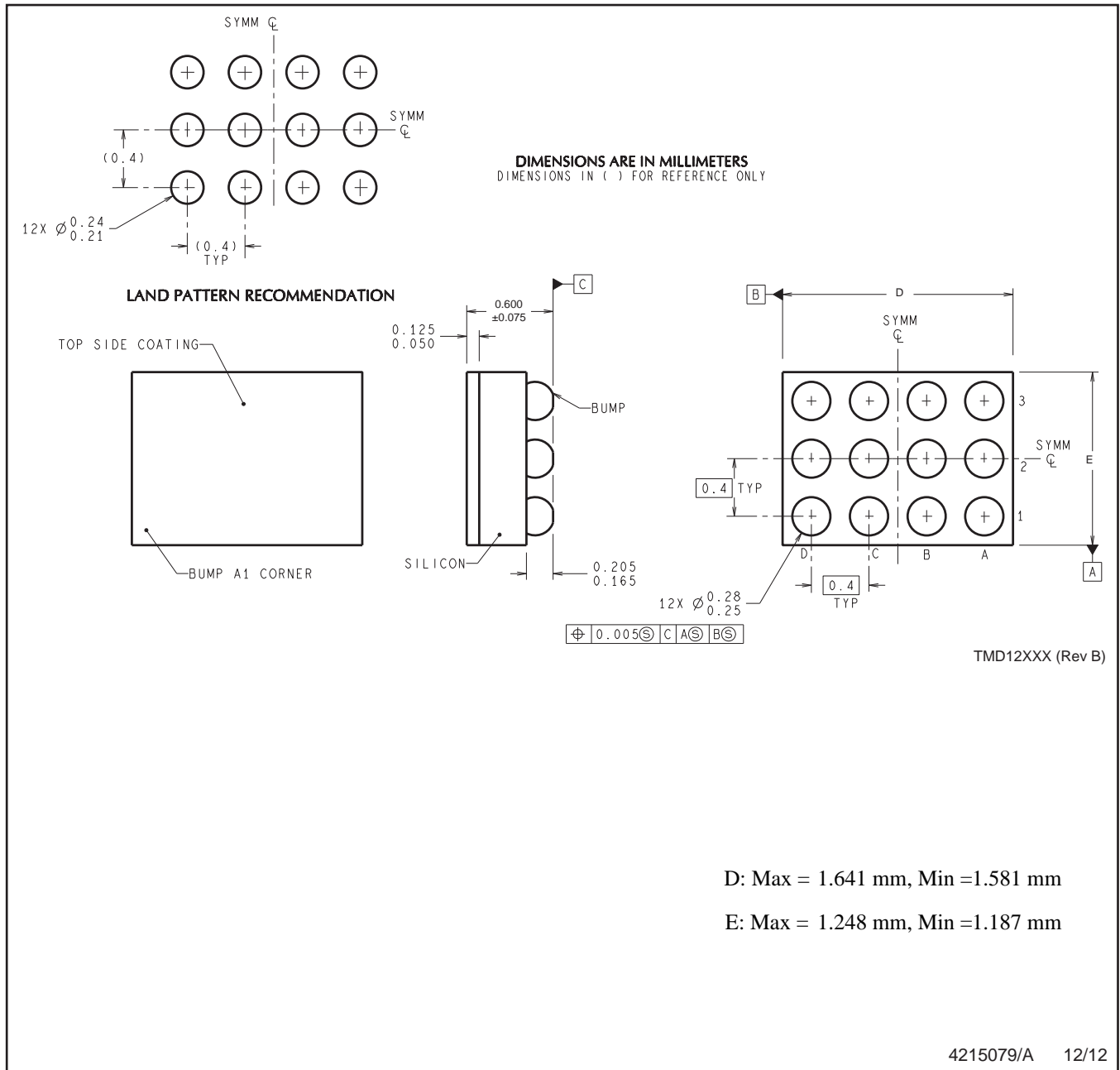

D: Max = 1.641 mm, Min = 1.581 mm

E: Max = 1.248 mm, Min = 1.187 mm

NOTES: A. All linear dimensions are in millimeters. Dimensioning and tolerancing per ASME Y14.5M-1994.
B. This drawing is subject to change without notice.

IMPORTANT NOTICE

Texas Instruments Incorporated and its subsidiaries (TI) reserve the right to make corrections, enhancements, improvements and other changes to its semiconductor products and services per JESD46, latest issue, and to discontinue any product or service per JESD48, latest issue. Buyers should obtain the latest relevant information before placing orders and should verify that such information is current and complete. All semiconductor products (also referred to herein as "components") are sold subject to TI's terms and conditions of sale supplied at the time of order acknowledgment.

TI warrants performance of its components to the specifications applicable at the time of sale, in accordance with the warranty in TI's terms and conditions of sale of semiconductor products. Testing and other quality control techniques are used to the extent TI deems necessary to support this warranty. Except where mandated by applicable law, testing of all parameters of each component is not necessarily performed.

TI assumes no liability for applications assistance or the design of Buyers' products. Buyers are responsible for their products and applications using TI components. To minimize the risks associated with Buyers' products and applications, Buyers should provide adequate design and operating safeguards.

TI does not warrant or represent that any license, either express or implied, is granted under any patent right, copyright, mask work right, or other intellectual property right relating to any combination, machine, or process in which TI components or services are used. Information published by TI regarding third-party products or services does not constitute a license to use such products or services or a warranty or endorsement thereof. Use of such information may require a license from a third party under the patents or other intellectual property of the third party, or a license from TI under the patents or other intellectual property of TI.

Reproduction of significant portions of TI information in TI data books or data sheets is permissible only if reproduction is without alteration and is accompanied by all associated warranties, conditions, limitations, and notices. TI is not responsible or liable for such altered documentation. Information of third parties may be subject to additional restrictions.

Resale of TI components or services with statements different from or beyond the parameters stated by TI for that component or service voids all express and any implied warranties for the associated TI component or service and is an unfair and deceptive business practice. TI is not responsible or liable for any such statements.

Buyer acknowledges and agrees that it is solely responsible for compliance with all legal, regulatory and safety-related requirements concerning its products, and any use of TI components in its applications, notwithstanding any applications-related information or support that may be provided by TI. Buyer represents and agrees that it has all the necessary expertise to create and implement safeguards which anticipate dangerous consequences of failures, monitor failures and their consequences, lessen the likelihood of failures that might cause harm and take appropriate remedial actions. Buyer will fully indemnify TI and its representatives against any damages arising out of the use of any TI components in safety-critical applications.

In some cases, TI components may be promoted specifically to facilitate safety-related applications. With such components, TI's goal is to help enable customers to design and create their own end-product solutions that meet applicable functional safety standards and requirements. Nonetheless, such components are subject to these terms.

No TI components are authorized for use in FDA Class III (or similar life-critical medical equipment) unless authorized officers of the parties have executed a special agreement specifically governing such use.

Only those TI components which TI has specifically designated as military grade or "enhanced plastic" are designed and intended for use in military/aerospace applications or environments. Buyer acknowledges and agrees that any military or aerospace use of TI components which have **not** been so designated is solely at the Buyer's risk, and that Buyer is solely responsible for compliance with all legal and regulatory requirements in connection with such use.

TI has specifically designated certain components as meeting ISO/TS16949 requirements, mainly for automotive use. In any case of use of non-designated products, TI will not be responsible for any failure to meet ISO/TS16949.

Products

Audio	www.ti.com/audio
Amplifiers	amplifier.ti.com
Data Converters	dataconverter.ti.com
DLP® Products	www.dlp.com
DSP	dsp.ti.com
Clocks and Timers	www.ti.com/clocks
Interface	interface.ti.com
Logic	logic.ti.com
Power Mgmt	power.ti.com
Microcontrollers	microcontroller.ti.com
RFID	www.ti-rfid.com
OMAP Applications Processors	www.ti.com/omap
Wireless Connectivity	www.ti.com/wirelessconnectivity

Applications

Automotive and Transportation	www.ti.com/automotive
Communications and Telecom	www.ti.com/communications
Computers and Peripherals	www.ti.com/computers
Consumer Electronics	www.ti.com/consumer-apps
Energy and Lighting	www.ti.com/energy
Industrial	www.ti.com/industrial
Medical	www.ti.com/medical
Security	www.ti.com/security
Space, Avionics and Defense	www.ti.com/space-avionics-defense
Video and Imaging	www.ti.com/video

TI E2E Community

e2e.ti.com

AMEYA360

Components Supply Platform

Authorized Distribution Brand :



Website :

Welcome to visit www.ameya360.com

Contact Us :

➤ Address :

401 Building No.5, JiuGe Business Center, Lane 2301, Yishan Rd
Minhang District, Shanghai , China

➤ Sales :

Direct +86 (21) 6401-6692

Email amall@ameya360.com

QQ 800077892

Skype [ameyasales1](#) [ameyasales2](#)

➤ Customer Service :

Email service@ameya360.com

➤ Partnership :

Tel +86 (21) 64016692-8333

Email mkt@ameya360.com