

USB 2.0 High-Speed/UART Dual SP3T (Dual 3 to 1 Multiplexer)

ISL54216

The Intersil ISL54216 is a single supply dual SP3T analog switch that operates from a single supply in the range of 2.7V to 4.6V. It was designed to multiplex between three different differential data sources, allowing the multiplexing of USB 2.0 high speed and/or UART data signals through a common headphone connector in Personal Media Players and other portable battery powered devices.

The switch channels have very low ON capacitance and high bandwidth to pass USB high speed signals (480Mbps) with minimal edge and phase distortion and can swing rail-to-rail to pass UART and full-speed USB signals.

The ISL54216 is available in a tiny 12 Ld 2.2mmx1.4mm ultra-thin QFN and 12 Ld 3mmx3mm TQFN packages. It operates over a temperature range of -40°C to +85°C.

Related Literature

- Technical Brief TB363 "Guidelines for Handling and Processing Moisture Sensitive Surface Mount Devices (SMDs)"

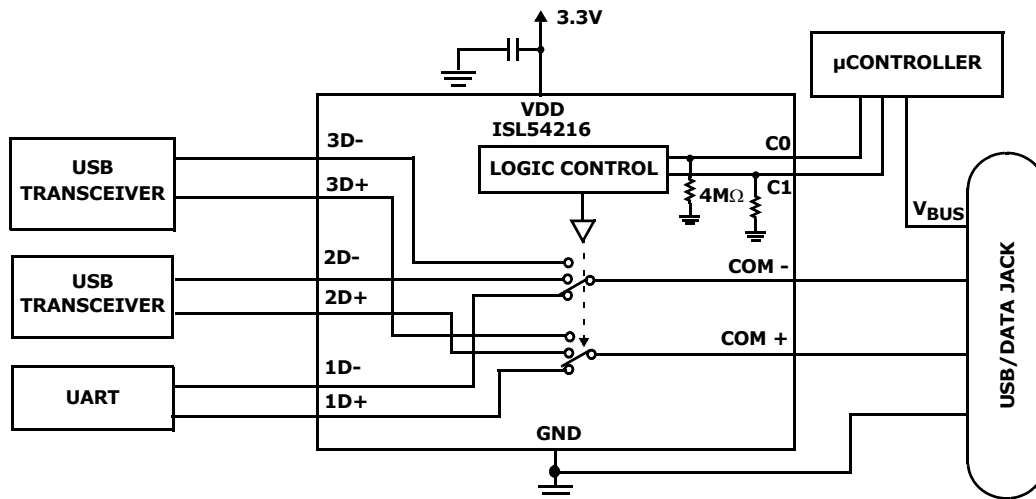
Features

- High Speed (480Mbps) and Full Speed (12Mbps) Signaling Capability per USB 2.0 on All Ports
- UART Capability on All Ports
- COM Pins Allow Negative Swings to -2V
- Compatible with Wired-OR Connected GND Referenced Audio Sources
- All Switches Open Mode
- Power OFF Protection
- COM Pins Overvoltage Tolerant to 5.5V
- Low ON Capacitance @ 240MHz 4pF
- -3dB Frequency 800MHz
- Single Supply Operation (V_{DD}) 2.7V to 4.6V
- Available 12 Ld μ TQFN and 12 Ld TQFN Packages
- Compliant with USB 2.0 Short Circuit Requirements Without Additional External Components
- Pb-Free (RoHS Compliant)

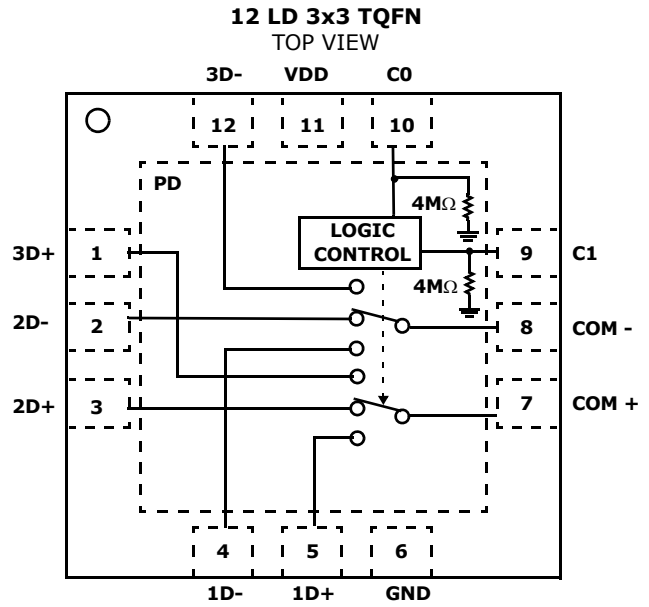
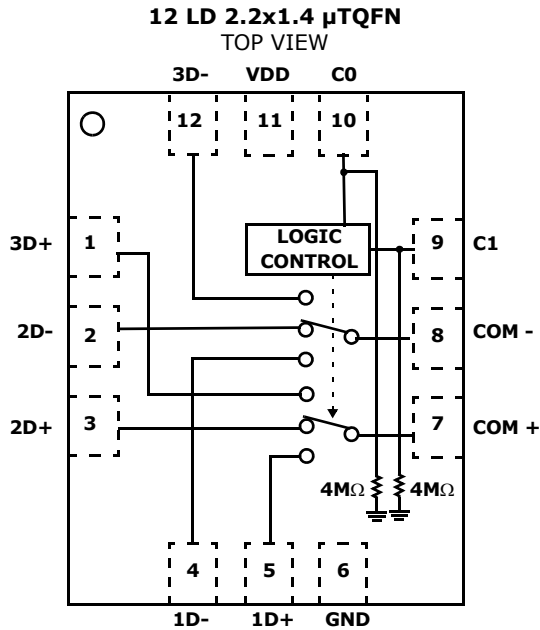
Applications* (see page 15)

- MP3 and Other Personal Media Players
- Cellular/Mobile Phone
- Readers

Application Block Diagram



Pin Configuration



NOTE:

1. ISL54216 Switches Shown for C1 = Logic "1" and C0 = Logic "0".

Pin Descriptions

μ TQFN	TQFN	NAME	FUNCTION
1	1	3D+	USB3 Differential Input
2	2	2D-	USB2 Differential Input
3	3	2D+	USB2 Differential Input
4	4	1D-	USB1 Differential Input
5	5	1D+	USB1 Differential Input
6	6	GND	Ground Connection
7	7	COM+	Data Common Pin
8	8	COM-	Data Common Pin
9	9	C1	Digital Control Input
10	10	C0	Digital Control Input
11	11	V _{DD}	Power Supply
12	12	3D-	USB3 Differential Input
-	PD	PD	Thermal Pad. Tie to Ground or Float

Truth Table

C1	C0	MODE	COMMENTS
0	0	Wired-OR Audio	All switches open
0	1	USB/UART #1	1D- and 1D+ ON
1	0	USB/UART #2	2D- and 2D+ ON
1	1	USB/UART #3	3D- and 3D+ ON

C0, C1: Logic "0" when $\leq 0.5V$ or float, Logic "1" when $\geq 1.4V$ with V_{DD} in range of 2.7V to 3.6V.

Ordering Information

PART NUMBER	PART MARKING	TEMP. RANGE (°C)	PACKAGE (Pb-Free)	PKG. DWG. #
ISL54216IRUZ-T (Notes 2, 3)	GY	-40 to +85	12 Ld 2.2mmx1.4mm μ TQFN (Tape and Reel)	L12.2.2x1.4A
ISL54216IRTZ (Note 4)	4216	-40 to +85	12 Ld 3mmx3mm TQFN	L12.3x3A
ISL54216IRTZ-T (Note 2, 4)	4216	-40 to +85	12 Ld 3mmx3mm TQFN (Tape and Reel)	L12.3x3A
ISL54216EVAL1Z	Evaluation Board			

NOTES:

- Please refer to [TB347](#) for details on reel specifications.
- These Intersil Pb-free plastic packaged products employ special Pb-free material sets; molding compounds/die attach materials and NiPdAu plate - e4 termination finish, which is RoHS compliant and compatible with both SnPb and Pb-free soldering operations. Intersil Pb-free products are MSL classified at Pb-free peak reflow temperatures that meet or exceed the Pb-free requirements of IPC/JEDEC J STD-020.
- These Intersil Pb-free plastic packaged products employ special Pb-free material sets, molding compounds/die attach materials, and 100% matte tin plate plus anneal (e3 termination finish, which is RoHS compliant and compatible with both SnPb and Pb-free soldering operations). Intersil Pb-free products are MSL classified at Pb-free peak reflow temperatures that meet or exceed the Pb-free requirements of IPC/JEDEC J STD-020.
- For Moisture Sensitivity Level (MSL), please see device information page for [ISL54216](#). For more information on MSL please see techbrief [TB363](#).

Absolute Maximum Ratings

V _{DD} to GND	-0.3V to 5.5V
Input Voltages	
1D+, 1D-, 2D+, 2D-, 3D+, 3D-	-2V to 5.5V
C0, C1 (Note 6)	-0.3V to 5.5V
Output Voltages	
COM-, COM+	-2V to 5.5V
Continuous Current (1D-, 1D+, 2D-, 2D+, 3D-, 3D+)	±40mA
Peak Current (1D-, 1D+, 2D-, 2D+, 3D-, 3D+)	
(Pulsed 1ms, 10% Duty Cycle, Max)	±100mA
ESD Rating:	
Human Body Model (Tested per JESD22-A114F)	>5kV
Machine Model (Tested per JESD22-A115B)	>400V
Charged Device Model (Tested per JESD22-C110D)	>2kV
Latch-up (Tested per JESD-78B; Class 2, Level A)	at +85°C

Thermal Information

Thermal Resistance (Typical)	θ_{JA} (°C/W)	θ_{JC} (°C/W)
12 Ld μ TQFN Package (Notes 7, 10)	155	90
12 Ld TQFN Package (Notes 8, 9)	58	1.0
Maximum Junction Temperature (Plastic Package)	+150°C	
Maximum Storage Temperature Range	-65°C to +150°C	
Pb-Free Reflow Profile	see link below	
	http://www.intersil.com/pbfree/Pb-FreeReflow.asp	

Operating Conditions

Temperature Range	-40°C to +85°C
Supply Voltage Range	2.7V to 4.6V

CAUTION: Do not operate at or near the maximum ratings listed for extended periods of time. Exposure to such conditions may adversely impact product reliability and result in failures not covered by warranty.

NOTES:

- Signals on C1 and C0 exceeding GND by specified amount are clamped. Limit current to maximum current ratings.
- θ_{JA} is measured with the component mounted on a high effective thermal conductivity test board in free air. See Tech Brief TB379 for details.
- θ_{JA} is measured in free air with the component mounted on a high effective thermal conductivity test board with "direct attach" features. See Tech Brief TB379.
- For θ_{JC} , the "case temp" location is the center of the exposed metal pad on the package underside.
- For θ_{JC} , the "case temp" location is taken at the package top center.

Electrical Specifications - 2.7V to 3.6V Supply Test Conditions: V_{DD} = +3.0V, GND = 0V, V_{COH}, V_{C1H} = 1.4V, V_{COL}, V_{C1L} = 0.5V, (Note 11), Unless Otherwise Specified. **Boldface limits apply over the operating temperature range, -40°C to +85°C.**

PARAMETER	TEST CONDITIONS	TEMP (°C)	MIN (Notes 12, 13)	TYP	MAX (Notes 12, 13)	UNITS
ANALOG SWITCH CHARACTERISTICS						
Analog Signal Range, V _{ANALOG}	V _{DD} = 2.7V to 4.6V	Full	-1	-	V_{DD}	V
ON-Resistance, r _{ON}	V _{DD} = 2.7V, I _{COMx} = 17mA, V _{D+} or V _{D-} = 0V to 400mV (see Figure 3, Note 15)	25	-	6	8	Ω
		Full	-	-	10	Ω
r _{ON} Matching Between Channels, Δr_{ON}	V _{DD} = 2.7V, I _{COMx} = 17mA, V _{D+} or V _{D-} = Voltage at max r _{ON} , (Notes 15, 16)	25	-	0.07	0.5	Ω
		Full	-	-	0.55	Ω
r _{ON} Flatness, R _{FLAT(ON)}	V _{DD} = 2.7V, I _{COMx} = 17mA, V _{D+} or V _{D-} = 0V to 400mV, (Notes 14, 15)	25	-	0.32	0.8	Ω
		Full	-	-	1.2	Ω
ON-Resistance, r _{ON}	V _{DD} = 3.3V, I _{COMx} = 17mA, V _{D+} or V _{D-} = 3.3V (See Figure 3, Note 15)	+25	-	9.5	15	Ω
		Full	-	-	20	Ω
OFF Leakage Current, I _{XD+(OFF)} or I _{XD-(OFF)} , I _{COMX(OFF)}	V _{DD} = 4.6V, All OFF Mode (C0 = 0.5V, C1 = 0.5V), V _{COM-} or V _{COM+} = 0.3V, 3.3V, V _{XD+} or V _{XD-} = 3.3V, 0.3V	25	-15	-	15	nA
		Full	-20	-	20	nA
ON Leakage Current, I _{XD+(ON)} or I _{XD-(ON)} , I _{COMX(ON)}	V _{DD} = 4.6V, V _{XD+} or V _{XD-} = 0.3V, 3.3V, V _{COM-} or V _{COM+} = 0.3V, 3.3V	25	-20	-	20	nA
		Full	-25	-	25	nA
DPDT DYNAMIC CHARACTERISTICS						
All OFF to ON or ON to All OFF Address Transition Time, t _{TRANS}	V _{DD} = 2.7V, R _L = 50 Ω , C _L = 10pF, (see Figure 1)	25	-	125	-	ns
Data Channel to Data Channel Address Transition Time, t _{TRANS}	V _{DD} = 2.7V, R _L = 50 Ω , C _L = 10pF, (see Figure 1)	25	-	125	-	ns
Break-Before-Make Time Delay, t _D	V _{DD} = 3.6V, R _L = 50 Ω , C _L = 10pF, (see Figure 2)	25	-	30	-	ns
Skew, (t _{SKEWOUT} - t _{SKEWIN})	V _{DD} = 3.0V, R _L = 45 Ω , C _L = 10pF, t _R = t _F = 500ps at 480Mbps, (Duty Cycle = 50%) (see Figure 6)	25	-	75	-	ps

ISL54216

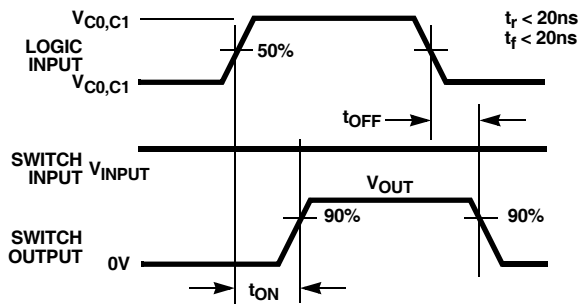
Electrical Specifications - 2.7V to 3.6V Supply Test Conditions: $V_{DD} = +3.0V$, $GND = 0V$, V_{C0H} , $V_{C1H} = 1.4V$, V_{C0L} , $V_{C1L} = 0.5V$, (Note 11), Unless Otherwise Specified. **Boldface limits apply over the operating temperature range, -40°C to +85°C. (Continued)**

PARAMETER	TEST CONDITIONS	TEMP (°C)	MIN (Notes 12, 13)	TYP	MAX (Notes 12, 13)	UNITS
Total Jitter, t_j	$V_{DD} = 3.0V$, $R_L = 50\Omega$, $C_L = 10pF$, $t_R = t_F = 500ps$ at 480Mbps	25	-	210	-	ps
Rise/Fall Degradation (Propagation Delay), t_{pD}	$V_{DD} = 3.0V$, $R_L = 45\Omega$, $C_L = 10pF$, (see Figure 6)	25	-	250	-	ps
Crosstalk	$V_{DD} = 3.0V$, $R_L = 50\Omega$, $f = 240MHz$	25	-	-36	-	dB
OFF-Isolation	$V_{DD} = 3.0V$, $R_L = 50\Omega$, $f = 240MHz$	25	-	-32	-	dB
-3dB Bandwidth	Signal = 0dBm, 0.2VDC offset, $R_L = 50\Omega$, $C_L = 5pF$	25	-	800	-	MHz
OFF Capacitance, C_{XD+OFF} , C_{XD-OFF}	$f = 1MHz$, $V_{DD} = 3.0V$ (see Figure 4)	25	-	3	-	pF
COM ON Capacitance, $C_{COM-(ON)}$, $C_{COM+(ON)}$	$f = 1MHz$, $V_{DD} = 3.0V$ (see Figure 4)	25	-	6	-	pF
COM ON Capacitance, $C_{COM-(ON)}$, $C_{COM+(ON)}$	$f = 240MHz$, $V_{DD} = 3.0V$	25	-	4	-	pF
POWER SUPPLY CHARACTERISTICS						
Power Supply Range, V_{DD}		Full	2.7		4.6	V
Positive Supply Current, I_{DD} (ALL OFF Mode)	$V_{DD} = 3.6V$, $C_1 = GND$, $C_0 = GND$	25	-	6.5	8	μA
		Full	-	-	15	μA
Positive Supply Current, I_{DD} (USB1 Mode)	$V_{DD} = 3.6V$, $C_1 = GND$, $C_0 = V_{DD}$	25	-	6.5	8	μA
		Full	-	-	15	μA
Positive Supply Current, I_{DD} (USB2 Mode)	$V_{DD} = 3.6V$, $C_1 = V_{DD}$, $C_0 = GND$	25	-	6.5	8	μA
		Full	-	-	15	μA
Positive Supply Current, I_{DD} (USB3 Mode)	$V_{DD} = 3.6V$, $C_0 = C_1 = V_{DD}$	25	-	6.5	8	μA
		Full	-	-	15	μA
Power OFF COMx Current, I_{COMx}	$V_{DD} = 0V$, $C_0 = C_1 = Float$, $COMx = 5.25V$	25	-	-	1	μA
Power OFF Logic Current, I_{C0} , I_{C1}	$V_{DD} = 0V$, $C_0 = C_1 = 5.25V$	25	-	11	-	μA
Power OFF D+/D- Current, I_{XD+} , I_{XD-}	$V_{DD} = 0V$, $C_0 = C_1 = Float$, $XD- = XD+ = 5.25V$	25	-	5	-	μA
DIGITAL INPUT CHARACTERISTICS						
C_0 , C_1 Voltage Low, V_{C0L} , V_{C1L}	$V_{DD} = 2.7V$ to $3.6V$	Full	-	-	0.5	V
C_0 , C_1 Voltage High, V_{C0H} , V_{C1H}	$V_{DD} = 2.7V$ to $3.6V$	Full	1.4	-	5.25	V
C_0 , C_1 Input Current, I_{C0L} , I_{C1L}	$V_{DD} = 3.6V$, $C_0 = C_1 = 0V$ or Float	Full	-50	6.2	50	nA
C_0 , C_1 Input Current, I_{C0H} , I_{C1H}	$V_{DD} = 3.6V$, $C_0 = C_1 = 3.6V$	Full	-2	1.6	2	μA
C_0 , C_1 Pull-Down Resistor, R_{Cx}	$V_{DD} = 3.6V$, $C_0 = C_1 = 3.6V$, Measure current into C_0 or C_1 pin and calculate resistance value.	Full	-	4	-	M Ω

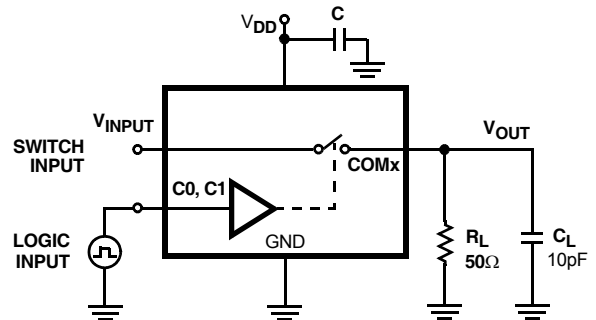
NOTES:

- V_{logic} = Input voltage to perform proper function.
- The algebraic convention, whereby the most negative value is a minimum and the most positive a maximum, is used in this data sheet.
- Parameters with MIN and/or MAX limits are 100% tested at +25°C, unless otherwise specified. Temperature limits established by characterization and are not production tested.
- Flatness is defined as the difference between maximum and minimum value of on-resistance over the specified analog signal range.
- Limits established by characterization and are not production tested.
- r_{ON} matching between channels is calculated by subtracting the channel with the highest max r_{ON} value from the channel with lowest max r_{ON} value, between 1D+ and 1D- or between 2D+ and 2D- or between 3D+ and 3D-.

Test Circuits and Waveforms



Logic input waveform is inverted for switches that have the opposite logic sense.



Repeat test for all switches. C_L includes fixture and stray capacitance.

$$V_{OUT} = V_{(INPUT)} \frac{R_L}{R_L + r_{ON}}$$

FIGURE 1A. ADDRESS t_{TRANS} MEASUREMENT POINTS

FIGURE 1B. ADDRESS t_{TRANS} TEST CIRCUIT

FIGURE 1. SWITCHING TIMES

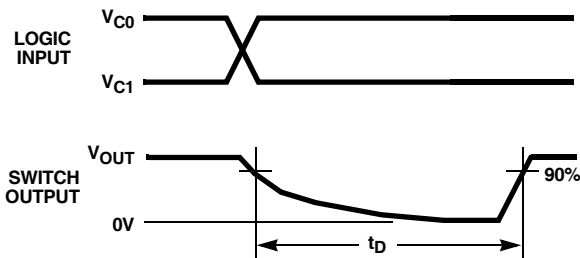
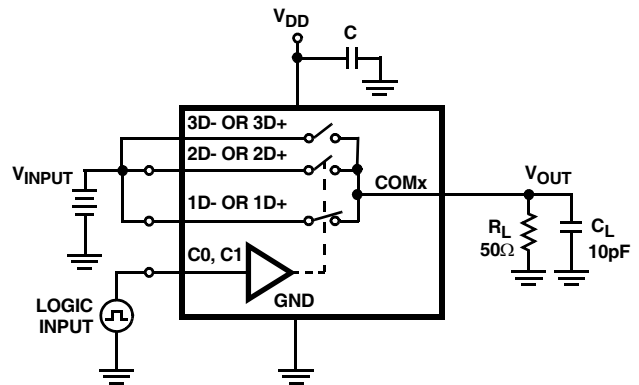


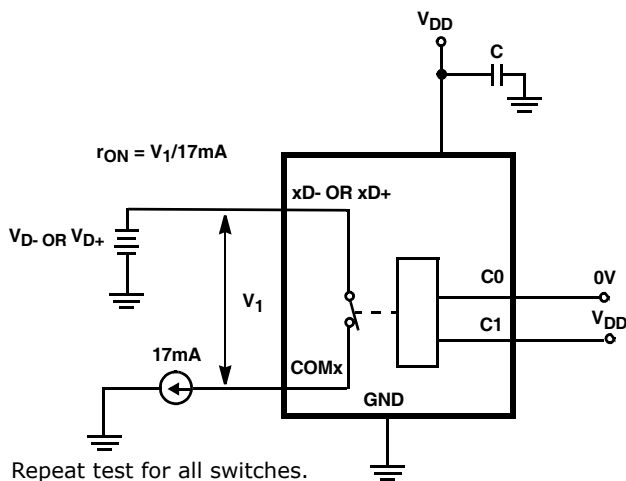
FIGURE 2A. MEASUREMENT POINTS



Repeat test for all switches. C_L includes fixture and stray capacitance.

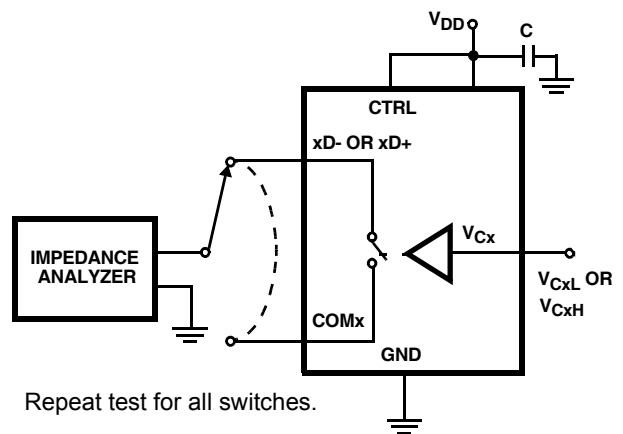
FIGURE 2B. TEST CIRCUIT

FIGURE 2. BREAK-BEFORE-MAKE TIME



Repeat test for all switches.

FIGURE 3. r_{ON} TEST CIRCUIT



Repeat test for all switches.

FIGURE 4. CAPACITANCE TEST CIRCUIT

Test Circuits and Waveforms (Continued)

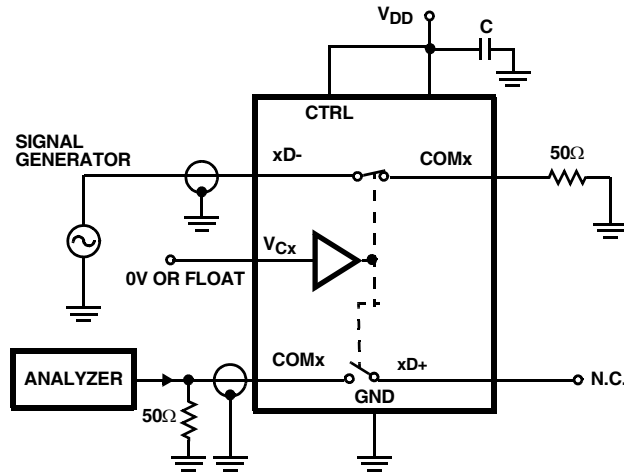


FIGURE 5. CROSTALK TEST CIRCUIT

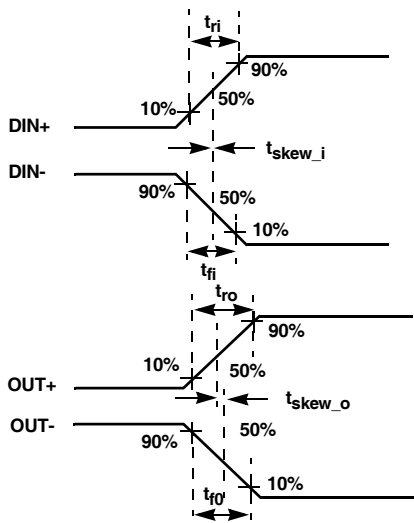
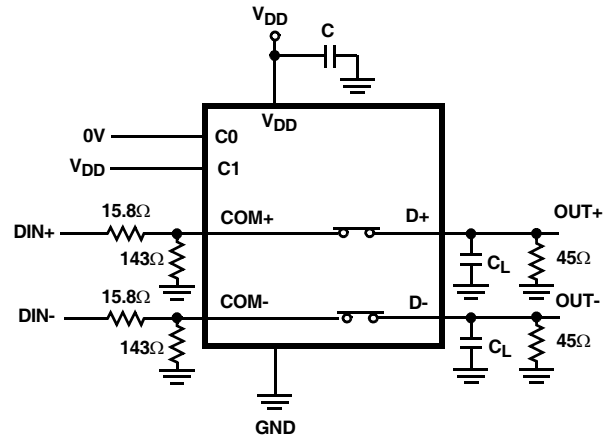


FIGURE 6A. MEASUREMENT POINTS

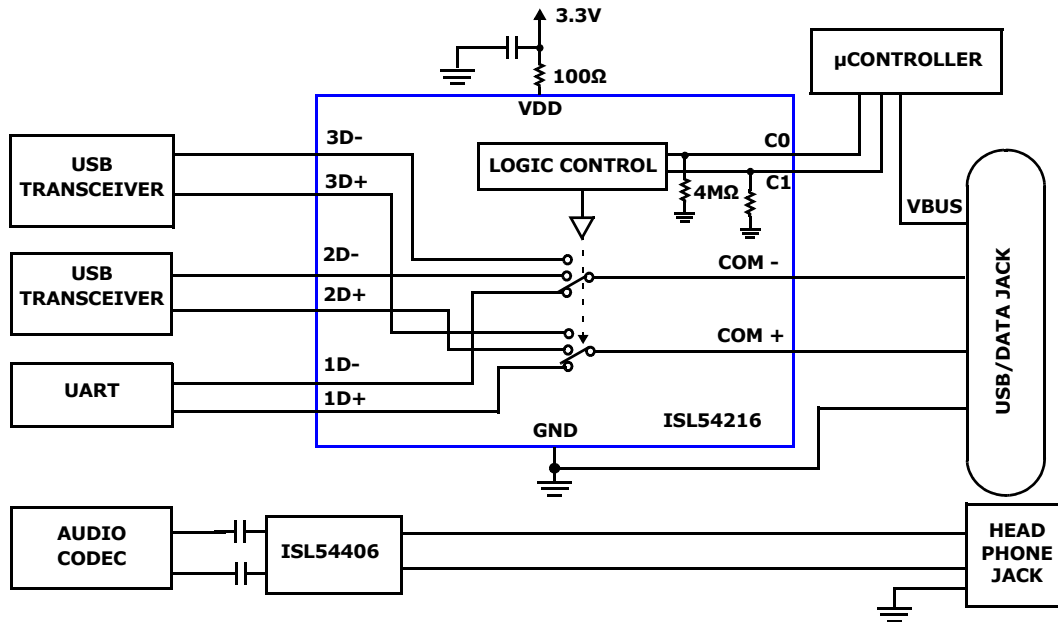


$|t_{ro} - t_{rj}|$ Delay Due to Switch for Rising Input and Rising Output Signals.
 $|t_{fo} - t_{fj}|$ Delay Due to Switch for Falling Input and Falling Output Signals.
 $|t_{skew_o}|$ Change in Skew through the Switch for Output Signals.
 $|t_{skew_i}|$ Change in Skew through the Switch for Input Signals.

FIGURE 6B. TEST CIRCUIT

FIGURE 6. SKEW TEST

Application Block Diagrams



Detailed Description

The ISL54216 device consists of dual SP3T (single pole/triple throw) analog switches. It operates from a single DC power supply in the range of 2.7V to 4.6V. It was designed to function as differential 3 to 1 multiplexer to select between three different differential data signals. Its offered in tiny μ TQFN and TQFN packages for use in MP3 players, PDAs, cellphones, and other personal media players.

A device consists of six 6Ω data switches. They were designed to pass high-speed USB differential data signals with minimal edge and phase distortion. They can swing rail-to-rail to pass UART and full-speed USB signals.

The COM pins can accept signals that swing below ground by as much as -2V. This allows an audio source to be wired-or connected at the COM pins.

The ISL54216 was specifically designed for MP3 players, personal media players and cellphone applications that need to combine three differential data channels into a single shared connector, thereby saving space and component cost. This functionality is shown in the Typical Application Block Diagram.

A detailed description of the switches is provided in the following sections.

Data Switches

The six data switches (1D+, 1D-, 2D+, 2D-, 3D+, 3D-) are 6Ω bidirectional switches that were specifically designed to pass high-speed USB differential data signals in the range of 0V to 400mV. The switches have low capacitance and high bandwidth to pass USB high-speed signals (480Mbps) with minimum edge and phase distortion to meet USB 2.0 signal quality specifications.

See Figures 11 and 12 for high-speed Eye Pattern taken with switch in the signal path.

These switches can also swing rail-to-rail and pass USB full-speed (12Mbps) and UART signals with minimal distortion. See Figure 13 for USB full-speed Eye Pattern taken with switch in the signal path.

The maximum normal operating signal range for the USB switches is from -1V to V_{DD} . The signal voltage at D- and D+ should not be allowed to exceed the V_{DD} voltage rail or go below ground by more than -1V for normal operation.

Fault Protection and Power-Off Protection

However, in the event that the USB 5.25V V_{BUS} voltage were shorted to one or both of the COM pins, the ISL54216 has fault protection circuitry to prevent damage to the ISL54216 part. The fault circuitry allows the signal pins (COM-, COM+, 1D-, 1D+, 2D-, 2D+, 3D-, 3D+) to be driven up to 5.25V while the V_{DD} supply voltage is in the range of 0V to 4.6V. This fault condition causes no stress to the IC.

In addition when V_{DD} is at 0V (ground) all switches are OFF and the fault voltage is isolated from the other side of the switch (Power-Off Protection).

When V_{DD} is in the range of 2.7V to 4.6V, the fault voltage will pass through to the output of an active switch channel. Note: During the fault condition normal operation is not guaranteed until the fault condition is removed.

ISL54216 Operation

The discussion that follows will discuss using the ISL54216 in the "Application Block Diagrams" on page 8.

POWER

The power supply connected at VDD (pin 11) provides power to the ISL54216 part. Its voltage should be kept in the range of 2.7V to 4.6V. In a typical application, V_{DD} will be in the range of 2.7V to 4.3V and will be connected to the battery or LDO of the MP3 player or cellphone.

A 0.01μF or 0.1μF decoupling capacitor should be connected from the VDD pin to ground to filter out any power supply noise from entering the part. The capacitor should be located as close to the VDD pin as possible.

LOGIC CONTROL

The state of the ISL54216 device is determined by the voltage at the C1 pin (pin 9) and the C0 pin (pin 10). Refer to the "Truth Table" on page 2.

The C1 pin and C0 pin are internally pulled low through 4MΩ resistors to ground and can be tri-stated or left floating.

The C1 pin and C0 pin can be driven with a voltage that is higher than the V_{DD} supply voltage. They can be driven up to 5.25V with the V_{DD} supply in the range of 2.7V to 4.6V. Driving the logic higher than the supply rail will cause the logic current to increase. With V_{DD} = 2.7V and V_{LOGIC} = 5.25V, I_{LOGIC} current is approximately 5.5μA.

Logic Control Voltage Levels

With V_{DD} in the range of 2.7V to 3.6V the logic levels are: C1, C0 = Logic "0" (Low) when ≤ 0.5V or Floating. C1, C0 = Logic "1" (High) when ≥ 1.4V.

ALL SWITCHES OFF Mode

If the C1 pin = Logic "0" and C0 pin = Logic "0" the part will be in the ALL SWITCHES OFF mode. In this mode, the 3D- and 3D+ data switches, the 2D- and 2D+ data switches, and the 1D- and 1D+ data switches will be OFF (high impedance).

The COM pins can accommodate signals that swing below ground by as much as -2V. This allows an audio CODEC to be connected to the COM pins when the device is in the all off state.

USB/UART1 Mode

If the C1 pin = Logic "0" and C0 pin = Logic "1" the part will go into USB/UART1 mode. The 1D- and 1D+ switches are ON and the 2D- and 2D+ switches and 3D- and 3D+ will be OFF (high impedance).

USB2 Mode

If the C1 = Logic "1" and C0 pin = Logic "0" the part will be in the USB/UART2 mode. The 2D- and 2D+ switches will be ON and the 1D- and 1D+ switches and the 3D- and 3D+ will be OFF (high impedance).

USB3 Mode

If the C1 pin = Logic "1" and C0 pin = Logic "1" the part will be in the USB/UART3 mode. The 3D- and 3D+ switches are ON, and the 1D- and 1D+ switches and 2D- and 2D+ switches will be OFF (high impedance).

Typical Performance Curves T_A = +25°C, Unless Otherwise Specified.

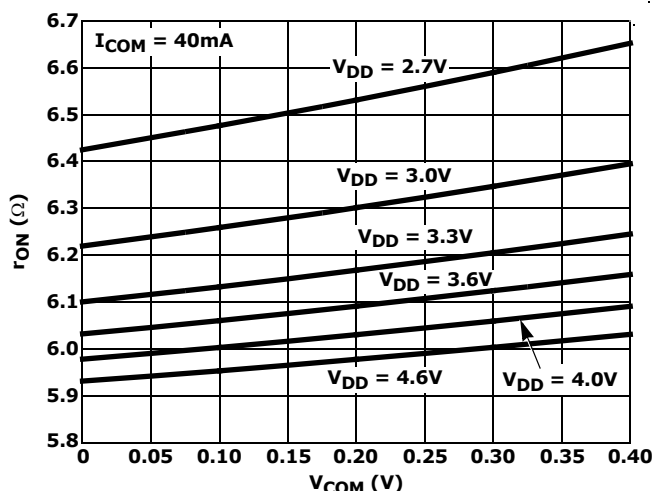


FIGURE 7. ON-RESISTANCE vs SUPPLY VOLTAGE vs SWITCH VOLTAGE

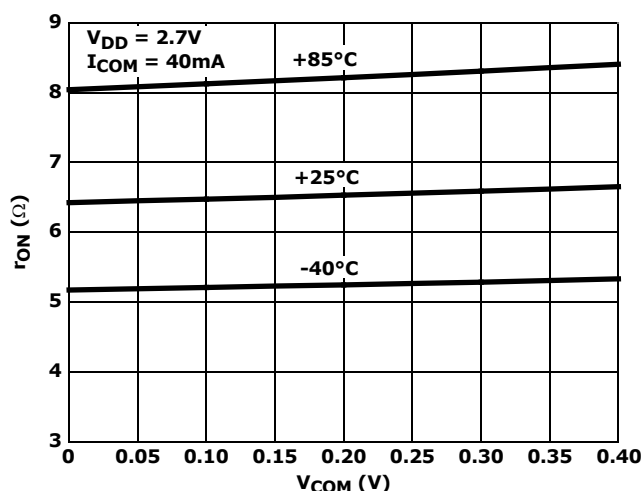


FIGURE 8. ON-RESISTANCE vs SWITCH VOLTAGE vs TEMPERATURE

Typical Performance Curves $T_A = +25^\circ\text{C}$, Unless Otherwise Specified. (Continued)

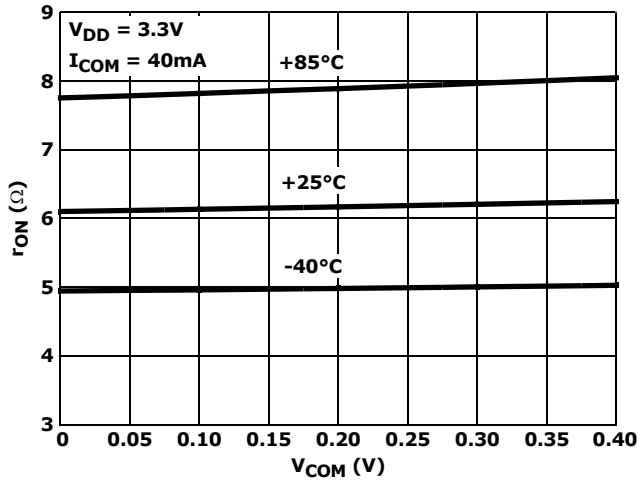


FIGURE 9. ON-RESISTANCE vs SWITCH VOLTAGE vs TEMPERATURE

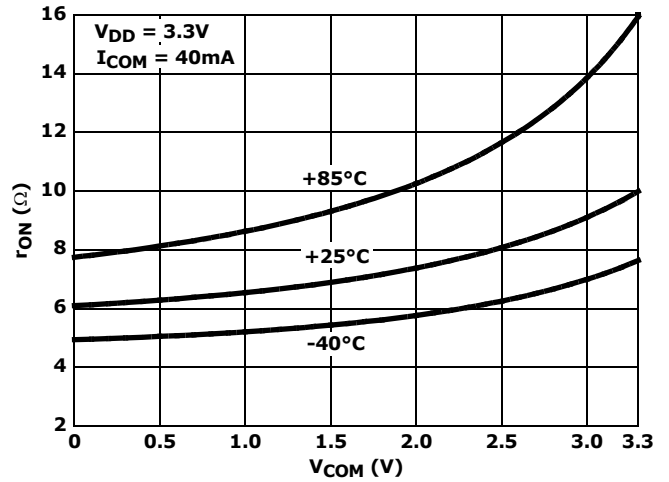


FIGURE 10. ON-RESISTANCE vs SWITCH VOLTAGE vs TEMPERATURE

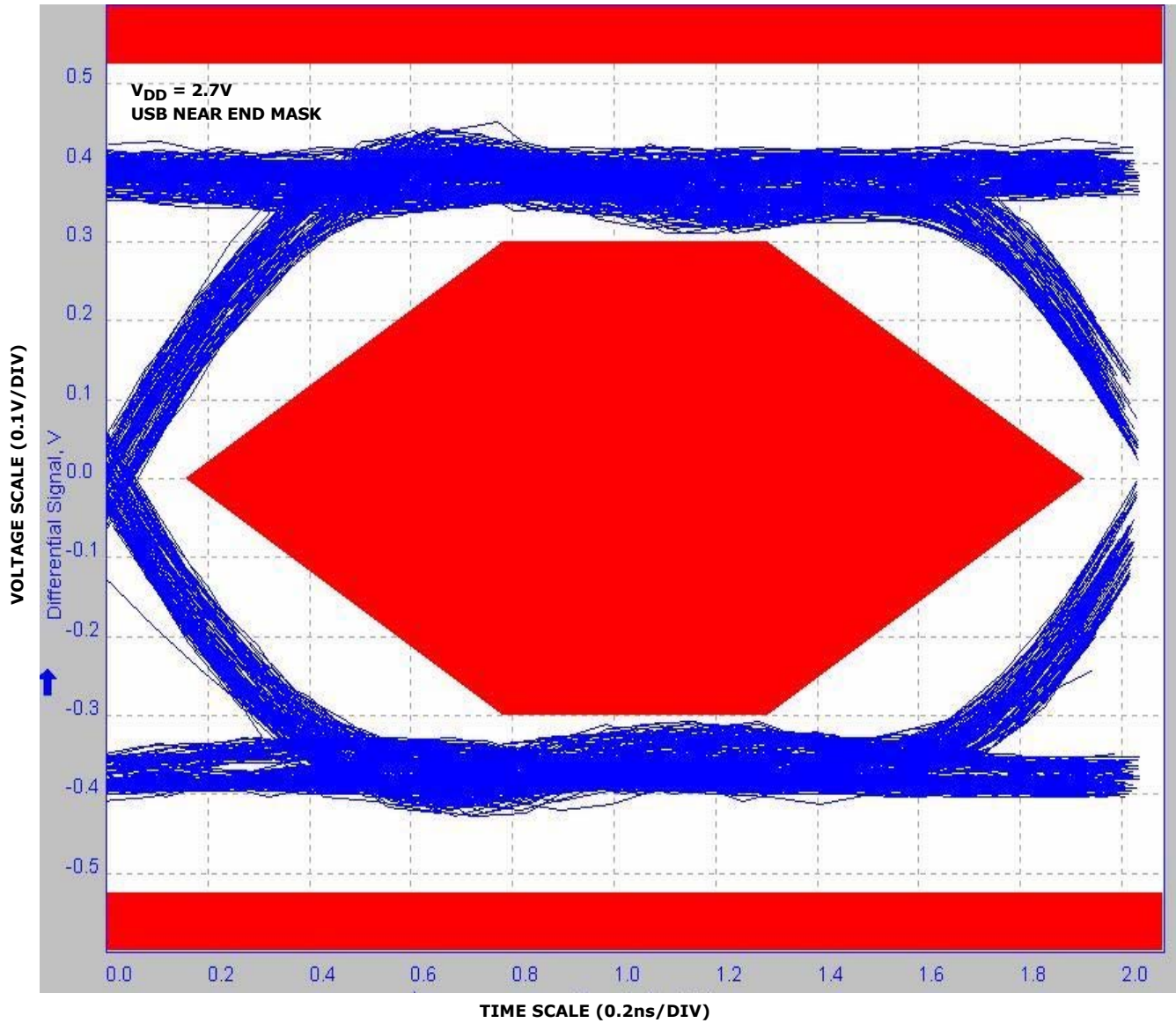
Typical Performance Curves $T_A = +25^\circ\text{C}$, Unless Otherwise Specified. (Continued)

FIGURE 11. EYE PATTERN: 480Mbps WITH USB SWITCHES IN THE SIGNAL PATH

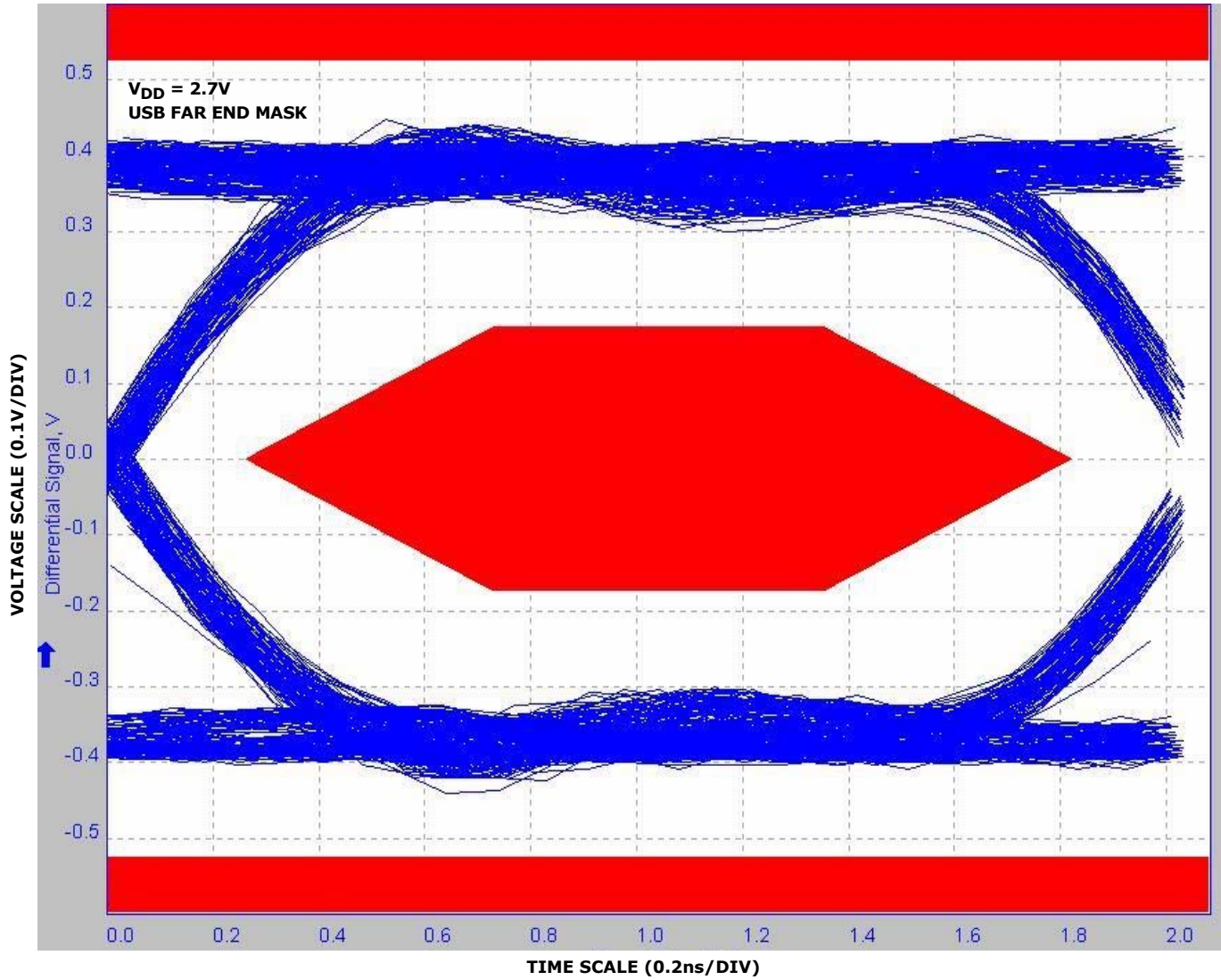
Typical Performance Curves $T_A = +25^\circ\text{C}$, Unless Otherwise Specified. (Continued)

FIGURE 12. EYE PATTERN: 480Mbps WITH USB SWITCHES IN THE SIGNAL PATH

Typical Performance Curves $T_A = +25^\circ\text{C}$, Unless Otherwise Specified. (Continued)

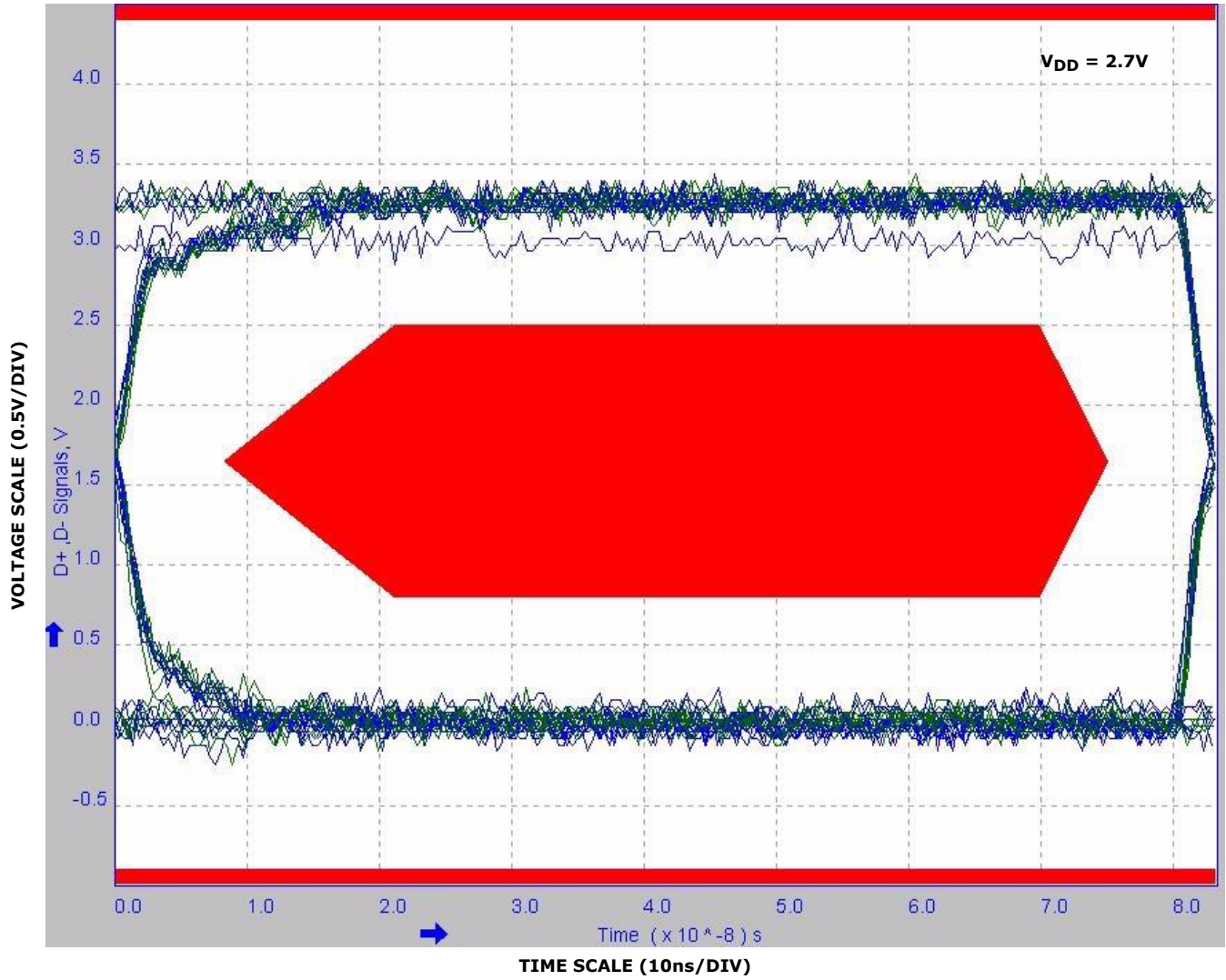


FIGURE 13. EYE PATTERN: 12Mbps USB SIGNAL WITH USB SWITCHES IN THE SIGNAL PATH

Typical Performance Curves $T_A = +25^\circ\text{C}$, Unless Otherwise Specified. (Continued)

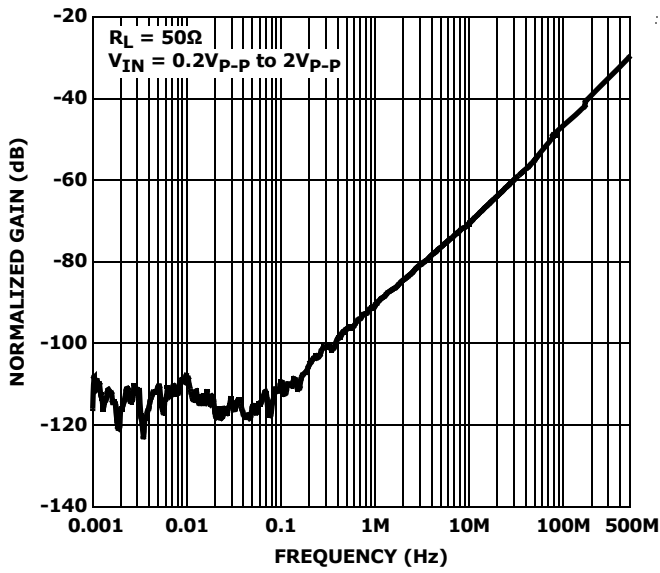


FIGURE 14. OFF-ISOLATION USB SWITCHES

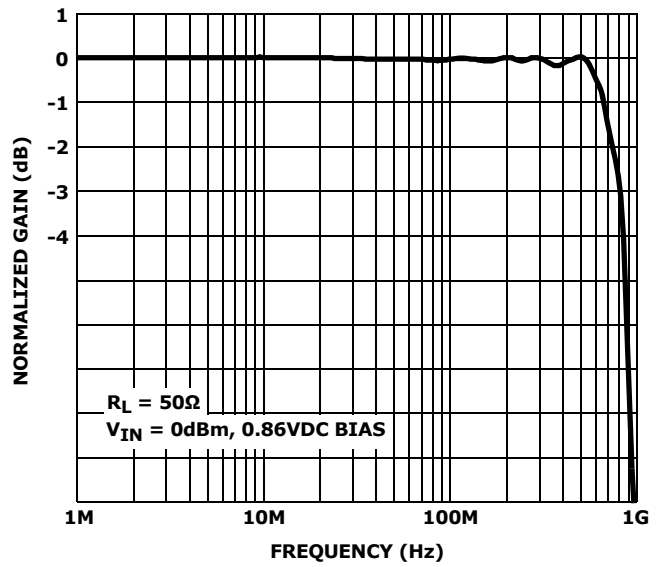


FIGURE 15. FREQUENCY RESPONSE

Die Characteristics

SUBSTRATE AND TQFN THERMAL PAD POTENTIAL (POWERED UP):

GND

TRANSISTOR COUNT:

837

PROCESS:

Submicron CMOS

Revision History

DATE	REVISION	CHANGE
9/27/10	FN7701.0	Initial Release.

Products

Intersil Corporation is a leader in the design and manufacture of high-performance analog semiconductors. The Company's products address some of the industry's fastest growing markets, such as, flat panel displays, cell phones, handheld products, and notebooks. Intersil's product families address power management and analog signal processing functions. Go to www.intersil.com/products for a complete list of Intersil product families.

*For a complete listing of Applications, Related Documentation and Related Parts, please see the respective device information page on intersil.com: [ISL54216](http://www.intersil.com/ISL54216)

To report errors or suggestions for this datasheet, please go to www.intersil.com/askourstaff

FITs are available from our website at <http://rel.intersil.com/reports/search.php>

For additional products, see www.intersil.com/product_tree

Intersil products are manufactured, assembled and tested utilizing ISO9000 quality systems as noted in the quality certifications found at www.intersil.com/design/quality

Intersil products are sold by description only. Intersil Corporation reserves the right to make changes in circuit design, software and/or specifications at any time without notice. Accordingly, the reader is cautioned to verify that data sheets are current before placing orders. Information furnished by Intersil is believed to be accurate and reliable. However, no responsibility is assumed by Intersil or its subsidiaries for its use; nor for any infringements of patents or other rights of third parties which may result from its use. No license is granted by implication or otherwise under any patent or patent rights of Intersil or its subsidiaries.

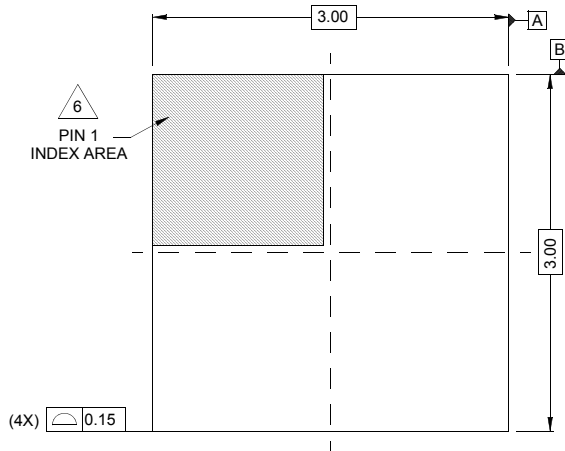
For information regarding Intersil Corporation and its products, see www.intersil.com

Package Outline Drawing

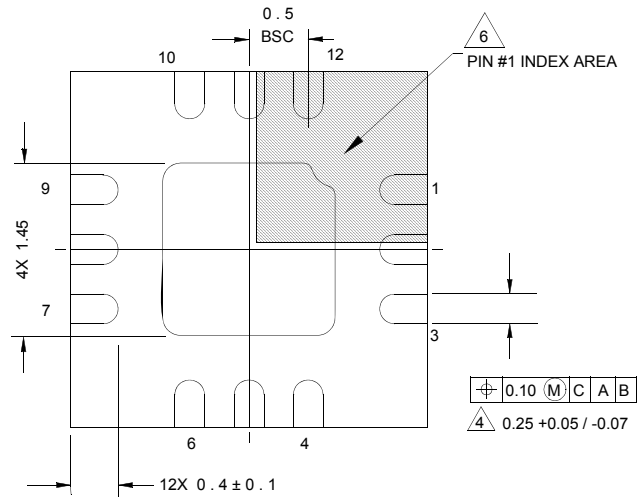
L12.3x3A

12 LEAD THIN QUAD FLAT NO LEAD PLASTIC PACKAGE

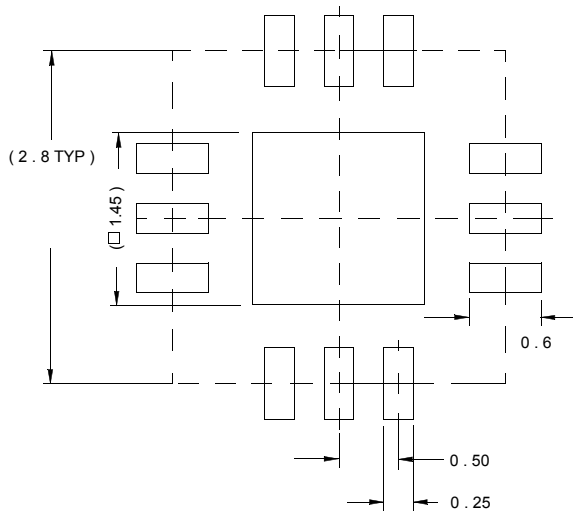
Rev 0, 09/07



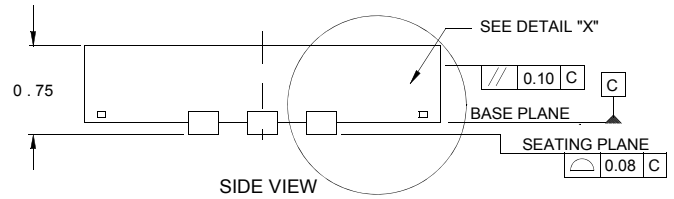
TOP VIEW



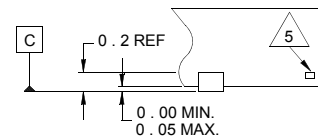
BOTTOM VIEW



TYPICAL RECOMMENDED LAND PATTERN



SIDE VIEW

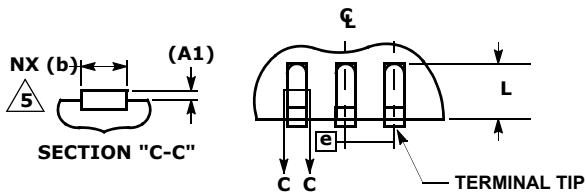
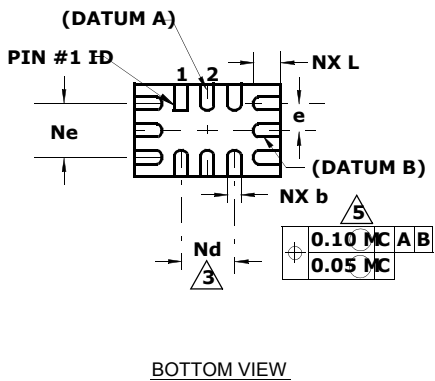
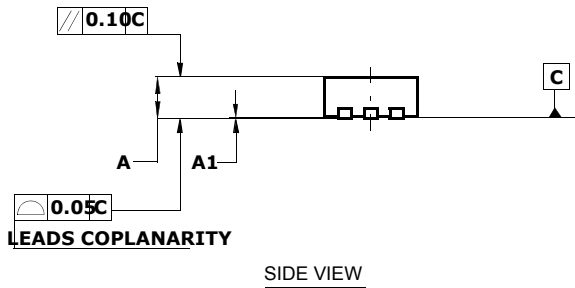
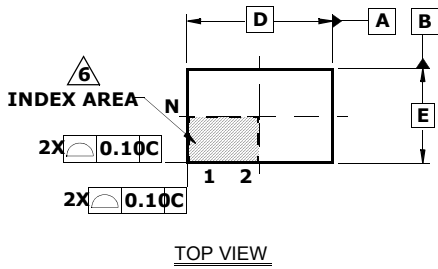


DETAIL "X"

NOTES:

1. Dimensions are in millimeters.
Dimensions in () for Reference Only.
2. Dimensioning and tolerancing conform to AMSE Y14.5m-1994.
3. Unless otherwise specified, tolerance : Decimal ± 0.05
4. Dimension b applies to the metallized terminal and is measured between 0.18mm and 0.30mm from the terminal tip.
5. Tiebar shown (if present) is a non-functional feature.
6. The configuration of the pin #1 identifier is optional, but must be located within the zone indicated. The pin #1 identifier may be either a mold or mark feature.

Ultra Thin Quad Flat No-Lead Plastic Package (UTQFN)



L12.2.2x1.4A

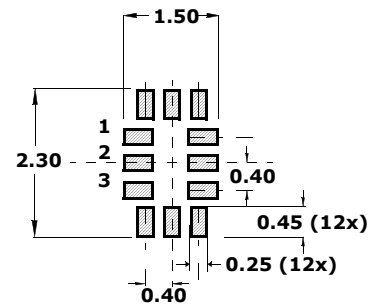
12 LEAD ULTRA THIN QUAD FLAT NO-LEAD PLASTIC PACKAGE

SYMBOL	MILLIMETERS			NOTES
	MIN	NOMINAL	MAX	
A	0.45	0.50	0.55	-
A1	-	-	0.05	-
A3	0.127 REF			-
b	0.15	0.20	0.25	5
D	2.15	2.20	2.25	-
E	1.35	1.40	1.45	-
e	0.40 BSC			-
k	0.20	-	-	-
L	0.35	0.40	0.45	-
N	12			2
Nd	3			3
Ne	3			3
θ	0	-	12	4

Rev. 0 12/06

NOTES:

1. Dimensioning and tolerancing conform to ASME Y14.5-1994.
2. N is the number of terminals.
3. Nd and Ne refer to the number of terminals on D and E side, respectively.
4. All dimensions are in millimeters. Angles are in degrees.
5. Dimension b applies to the metallized terminal and is measured between 0.15mm and 0.30mm from the terminal tip.
6. The configuration of the pin #1 identifier is optional, but must be located within the zone indicated. The pin #1 identifier may be either a mold or mark feature.
7. Maximum package warpage is 0.05mm.
8. Maximum allowable burrs is 0.076mm in all directions.
9. Same as JEDEC MO-255UABD except:
No lead-pull-back, "A" MIN dimension = 0.45 not 0.50mm
"L" MAX dimension = 0.45 not 0.42mm.
10. For additional information, to assist with the PCB Land Pattern Design effort, see Intersil Technical Brief TB389.



TYPICAL RECOMMENDED LAND PATTERN



AMEYA360

Components Supply Platform

Authorized Distribution Brand :



Website :

Welcome to visit www.ameya360.com

Contact Us :

➤ Address :

401 Building No.5, JiuGe Business Center, Lane 2301, Yishan Rd
Minhang District, Shanghai , China

➤ Sales :

Direct +86 (21) 6401-6692

Email amall@ameya360.com

QQ 800077892

Skype [ameyasales1](#) [ameyasales2](#)

➤ Customer Service :

Email service@ameya360.com

➤ Partnership :

Tel +86 (21) 64016692-8333

Email mkt@ameya360.com