

# ISL9519EVAL1Z Evaluation Board Setup Procedure

The ISL9519 is a highly integrated battery charger controller for Li-ion/Li-ion polymer batteries with SMBus interface controlling system voltage, charge current and input current limiting. The evaluation board includes a USB to SMBus interface to allow users to control the ISL9519 from a Personal Computer.

## What's Inside

This Evaluation Board Kit contains the following materials:

- Qty (1) ISL9519EVAL1Z Evaluation Board
- Qty (1) USB cable

## What is Needed

The following materials are recommended to perform testing:

- One adjustable 25V 6A power supply
- Two adjustable electronic loads with constant current mode and constant voltage mode.
- One Volt Meter
- One 500MHz four-channel oscilloscope with voltage and current probes
- A Personal Computer (PC) with ISL9519 control software and drivers (all available at [www.intersil.com](http://www.intersil.com))

Note: The National Instruments Runtime Engine must be installed before connecting the evaluation board to your PC. The Runtime Engine contains driver files required by the New Hardware Wizard.

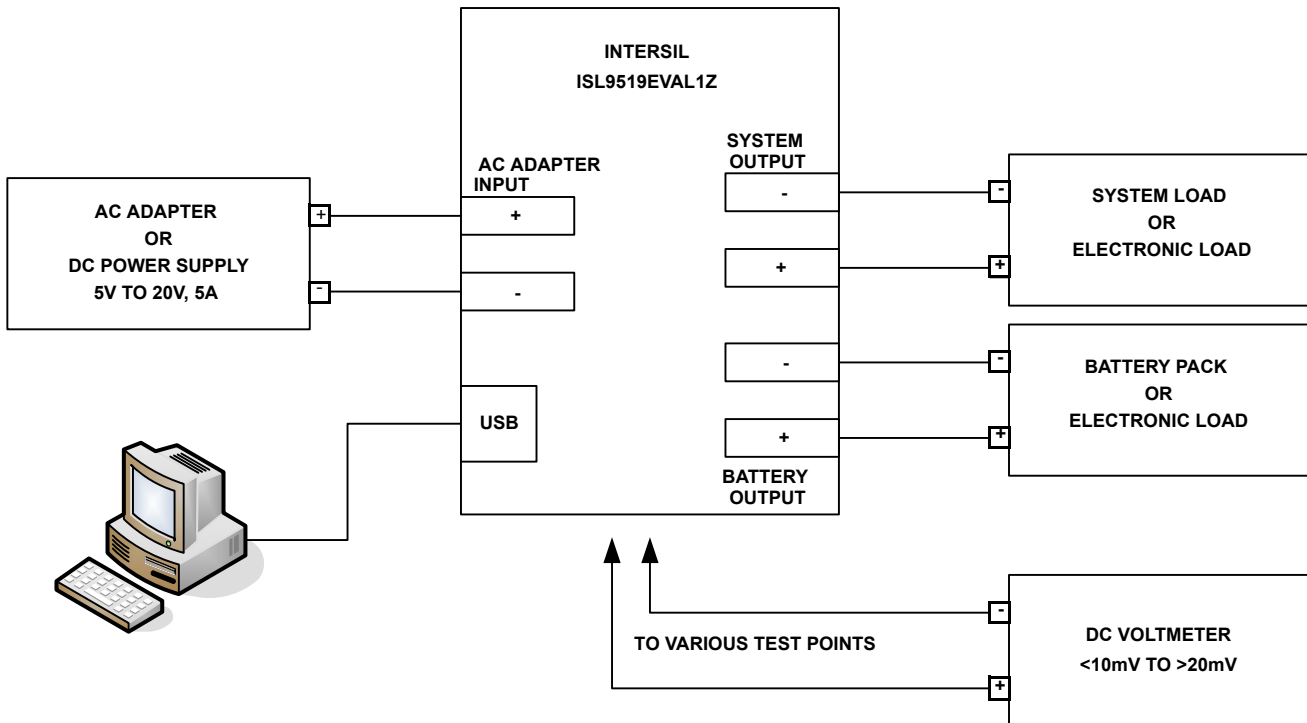

FIGURE 1. ISL9519EVAL1Z HARDWARE CONNECTION DIAGRAM

## Application Note 1562

### Install the Software

Download the ISL9519 CONTROL Software Installer.zip file from [www.intersil.com](http://www.intersil.com). Extract it a folder on your PC. Navigate to the folder and double click the "Autoexec.exe" file.

Click on the "Install or Uninstall ISL9519 CONTROL Software" to run the Installation Wizard.

You should now see a window as shown in Figure 3.

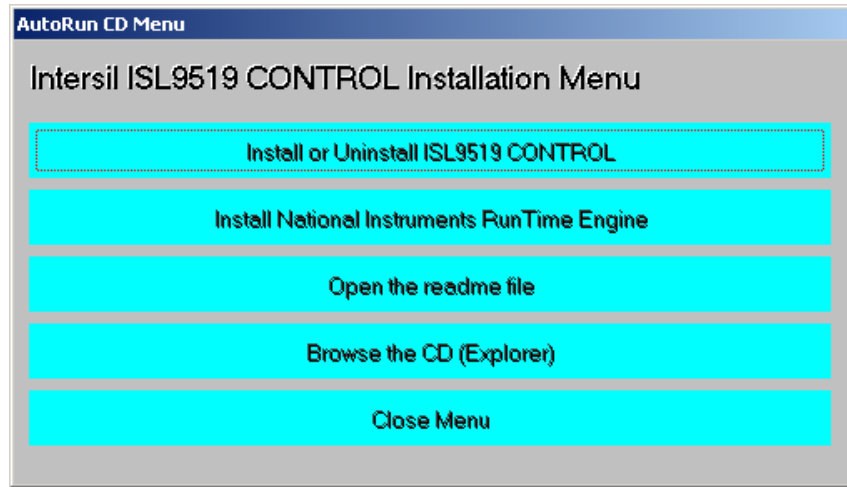
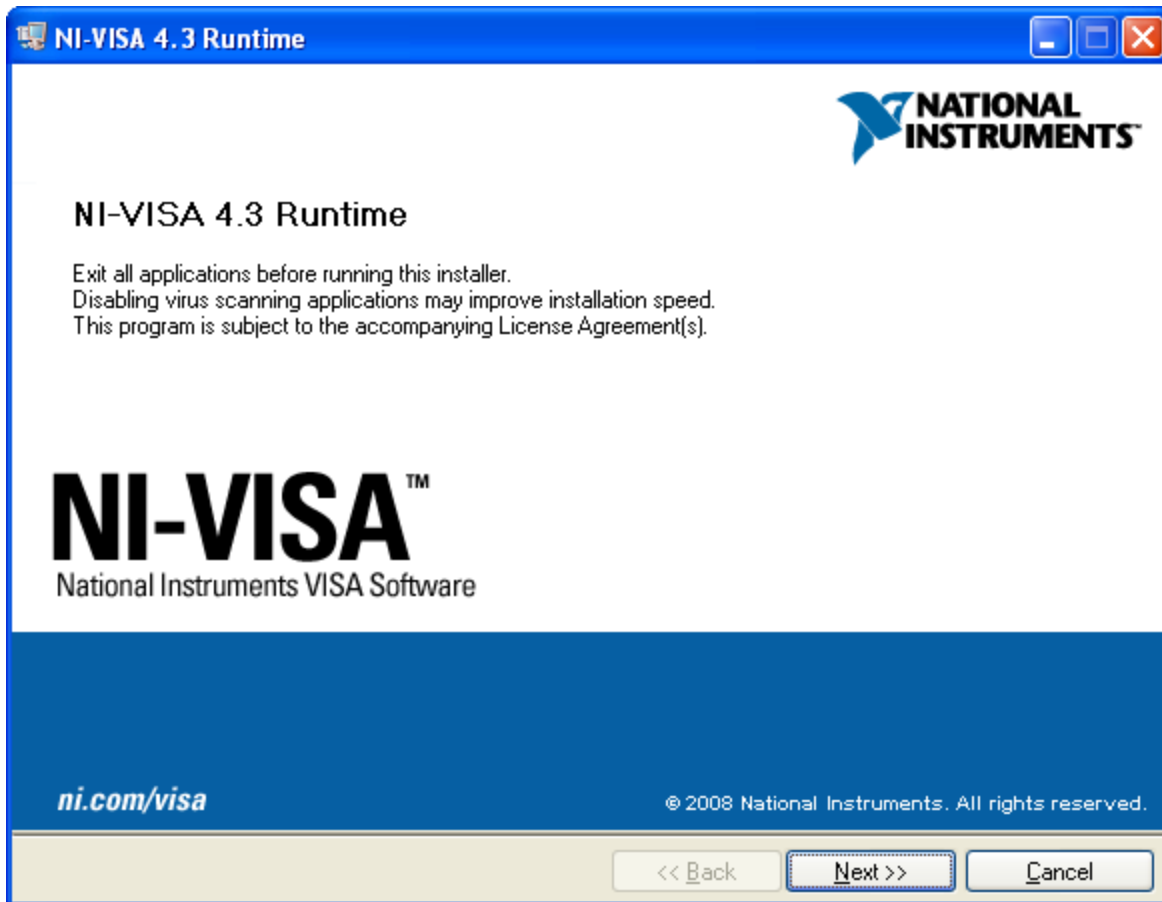

FIGURE 2. ISL9519EVAL1Z CONTROL SOFTWARE INSTALLATION MENU



FIGURE 3. ISL9519EVAL1Z INSTALLATION WIZARD



**FIGURE 4. NATIONAL INSTRUMENTS RUNTIME ENGINE INSTALLATION WIZARD**

In most PCs the National Instruments Runtime Engine will be installed automatically after the ISL9519 software. You should see the window as shown in Figure 4.

Follow the instructions to install the Runtime Engine. If it does not run automatically, click "Install National Instruments Runtime Engine" on the ISL9519 Control Software Installation Menu (see Figure 2). After installation, click on the Close Menu button.

### **Driver Installation**

After installing the National Instruments Run-Time Engine, Connect the ISL9519EVAL1Z to the USB port of your PC.

Note: The SMBus part of the ISL9519 and the USB-SMBus interface are powered by the 5V from the USB port on the PC. It is not necessary to have other power supplies connected to the evaluation board to read or write to the ISL9519.

When WINDOWS detects new hardware, the new hardware wizard should appear. Direct it to look for the driver information file in the "ISL9519 CONTROL Software Installer" folder (extracted from the downloaded file). In some systems, it may be necessary to specify the driver information file (USB-I2C\_WDM.inf).

### **Run the ISL9519 Application**

ISL9519 should now appear in your START/ALL Programs list. Click on it to run the application.

Figure 5 shows a screen shot of the ISL9519 user interface.

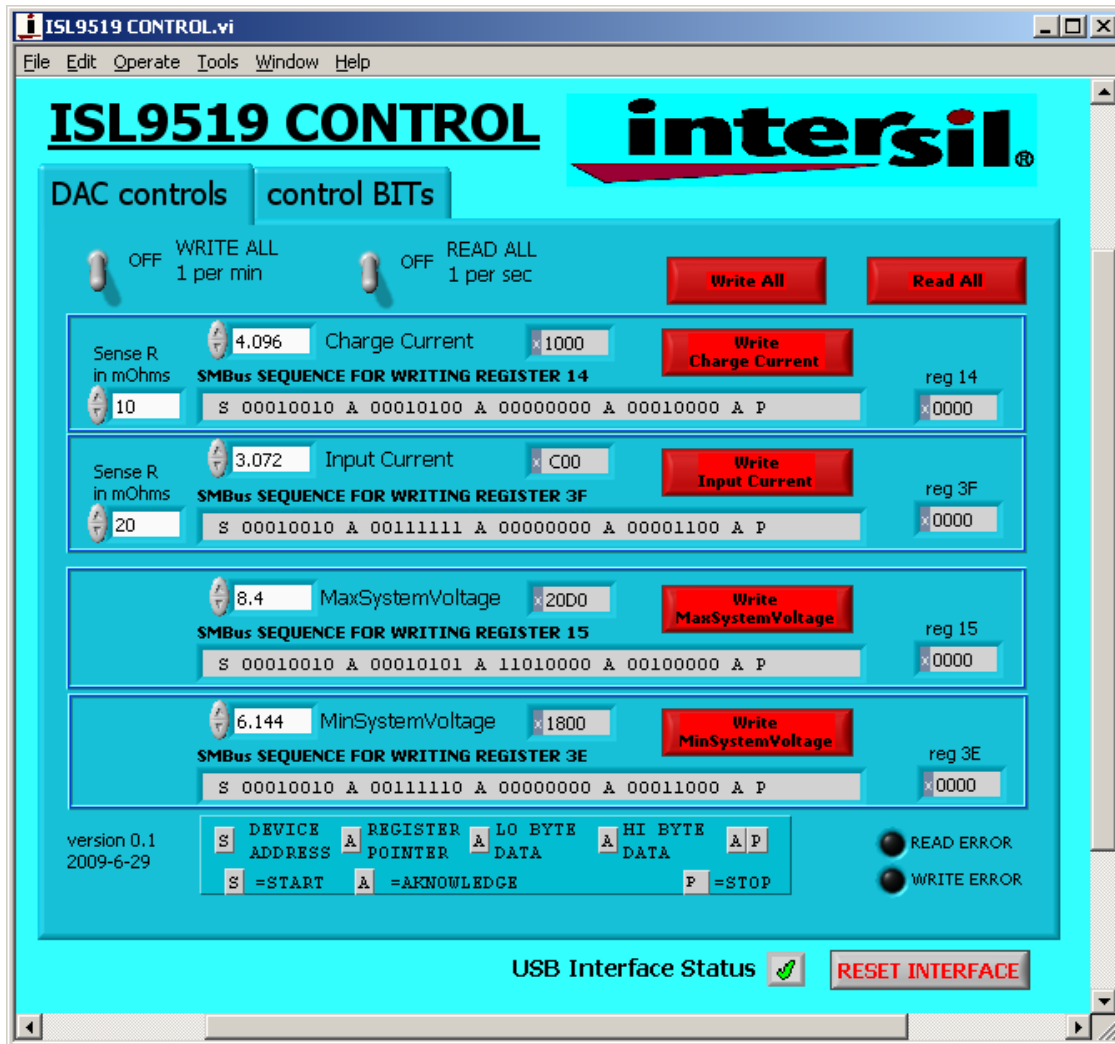

FIGURE 5. ISL9519 CONTROL SOFTWARE SCREEN SHOT

### Enable the Output

When power is applied to the ISL9519, the Charge Current and Charge Voltage Registers are 0x0000 and the output is disabled. The output is enabled by writing valid, non-zero values to these 2 registers. See the ISL9519 datasheet for valid values.

The ISL9519 is also disabled if the ACIN pin is below 3.2V. An Input voltage >13.1V will pull ACIN above 3.2V. The minimum input voltage can be adjusted on the evaluation board by changing R<sub>6</sub> or R<sub>7</sub> (see Figure 11).

### Description of the User Interface Controls and Display Information

Clicking the “Write All” button will write the indicated SMBus sequences to Registers 14, 15, 3F and 44 in the ISL9519.



Note: The SMBus part of the ISL9519 and the USB interface are powered by the 5V from the USB port on the PC. It is not necessary to have other power supplies connected to the evaluation board to read or write to the ISL9519.

Clicking on the “Read All” button will read all 6 registers in the ISL9519 and display the results in the grey indicators below the Read All button.



If the device and the interface are operating normally, the VendorID (reg FE) and the DeviceID (reg FF) will display as follows:



If the VendorID (reg FE) and DeviceID (reg FF) remain 0000 it indicates a communication problem.

## Application Note 1562

If the Visa resource name is blank, it indicates a problem with the USB communication.

Clicking on the "RESET INTERFACE" button may correct the problem. If not, try closing the software, remove power and USB connections from the evaluation board, then reconnect and restart.

Note the register contents are updated ONLY when the Read All button is clicked.



The Write Charge Current Button sends only the charge current to the ISL9519. Other registers are unchanged.



The small white window next to "Charge Current" accepts inputs in Amps, and converts them the hexadecimal (hex) value to be written to the ISL9519 in the grey window. The hex value depends on the value entered in Sense R. The value in the white window will be forced to the nearest valid number that can be produced by the DAC in the ISL9519. That is, after entering 4 and hitting the enter key, the display will change to 3.968. After entering 4.1 and hitting the enter key, the display will change to 4.096. The value can be incremented and decremented with the up/down arrows at the left of the window.



The Sense R inputs are used to calculate the hexadecimal (hex) values and the SMBus sequences for the Charge Current limit and Input Current limit entered in the white boxes. The evaluation board is built with 10mΩ sense resistors. If you change them to another value, enter the new value to get correct calculations.

After entering a number in the white box, hitting the enter key or clicking on another area will enter the value and the resulting hex value and the SMBus sequence will be calculated and displayed.

SMBus SEQUENCE FOR WRITING REGISTER 3E					
S	DEVICE ADDRESS	REGISTER POINTER	LO BYTE DATA	HI BYTE DATA	P
S	00010010	A 00111110	A 00000000	A 00011000	A P

S = the Start condition, A = the Acknowledge, P = the Stop condition.

Note: The LO byte is sent first. The HI byte is sent second.

When writing 0x41A0, 0xA0 is written first and 0x41 is sent second.

**Important Note: The SMBus commands are NOT sent until one of the WRITE buttons is clicked (i.e. Write All or Write Charge Current)**

**Important Note: Max System Voltage Commands that a much higher than the voltage for the number of cells selected by the CELL pin are ignored (not acknowledged). Please refer to the Max System Voltage section of the datasheet for details.**

The Write MaxSystem Voltage button writes only the MaxSystem Voltage register. Other registers are unchanged.

The small white window accepts Max System Voltage (in Volts) and calculates the hexadecimal value and the SMBus sequence to write to the ISL9519. The SMBus command is sent when the Write MaxSystem Voltage or Write All button is clicked. See Figure 8.

The Write Input Current button writes only the Charge Current register. Other registers are unchanged. The small white window accepts Input Current Limit in Amps and calculates the hex value and the SMBus sequence to be written to the ISL9519. The Sense R input is used to calculate the hex value and the SMBus sequence. The SMBus command is sent when the Write Input Current or Write All button is clicked. See Figure 9.

The ISL9519 will shut down unless it receives MaxSystem Voltage or Charge Current commands every 175s. This is a safety feature that prevents overcharging batteries if bus master has stopped functioning. A toggle switch can be set to tell the software to write all commands every 60 seconds.



# Application Note 1562

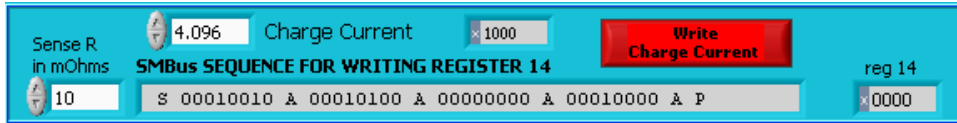

FIGURE 6. WRITE CHARGE CURRENT

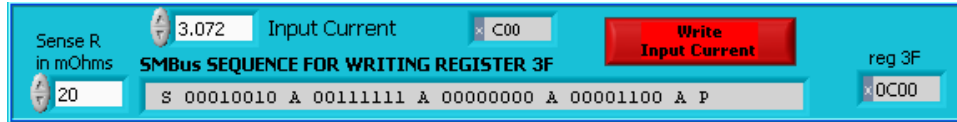

FIGURE 7. WRITE INPUT CURRENT



FIGURE 8. WRITE MAX SYSTEM VOLTAGE



FIGURE 9. WRITE MIN SYSTEM VOLTAGE

## Interface Troubleshooting

When the evaluation board is connected to the PC by a USB cable and communicates with the interface on the evaluation board a green check mark will appear next to the USB Interface Status.

If there is a red X instead of the green check, it indicates a problem with communication between the PC and the micro controller on the evaluation board. Check and correct the connection of the USB cable to your PC and the evaluation board. Click on the "RESET INTERFACE" button.

If you still get a red X, Close and restart the ISL9519 control software.

If you still get a red X, Open the Device Manager (Control Panel/System/Device Manager) with the ISL9519EVAL1Z evaluation board connected to your USB port. You should see a device named "NI-VISA USB Device". If it is not in the list of devices, the driver may not be correctly installed. Run the New Hardware wizard.

If you still get a red X, contact an Intersil Field Application Engineer for assistance.



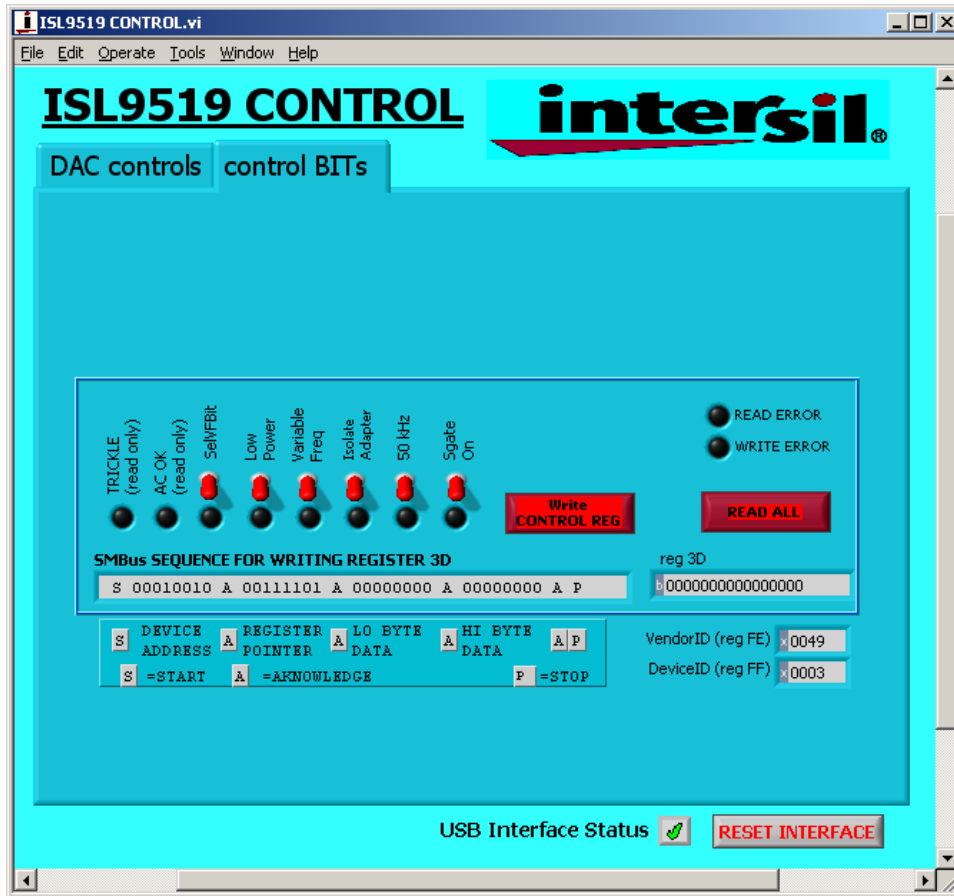

FIGURE 10. WRITE THE CONTROL REGISTER

# ISL9519EVAL1Z Schematics

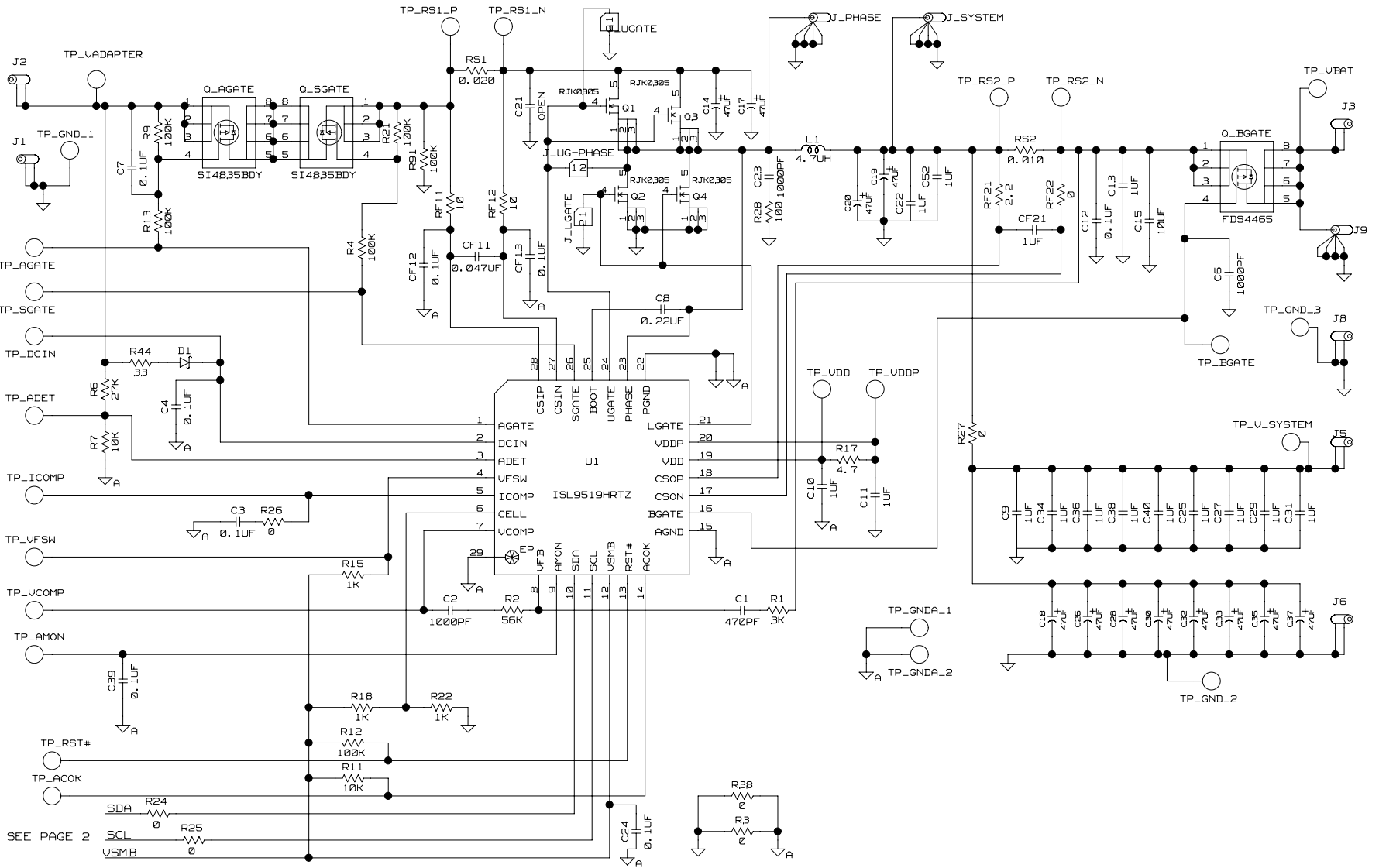
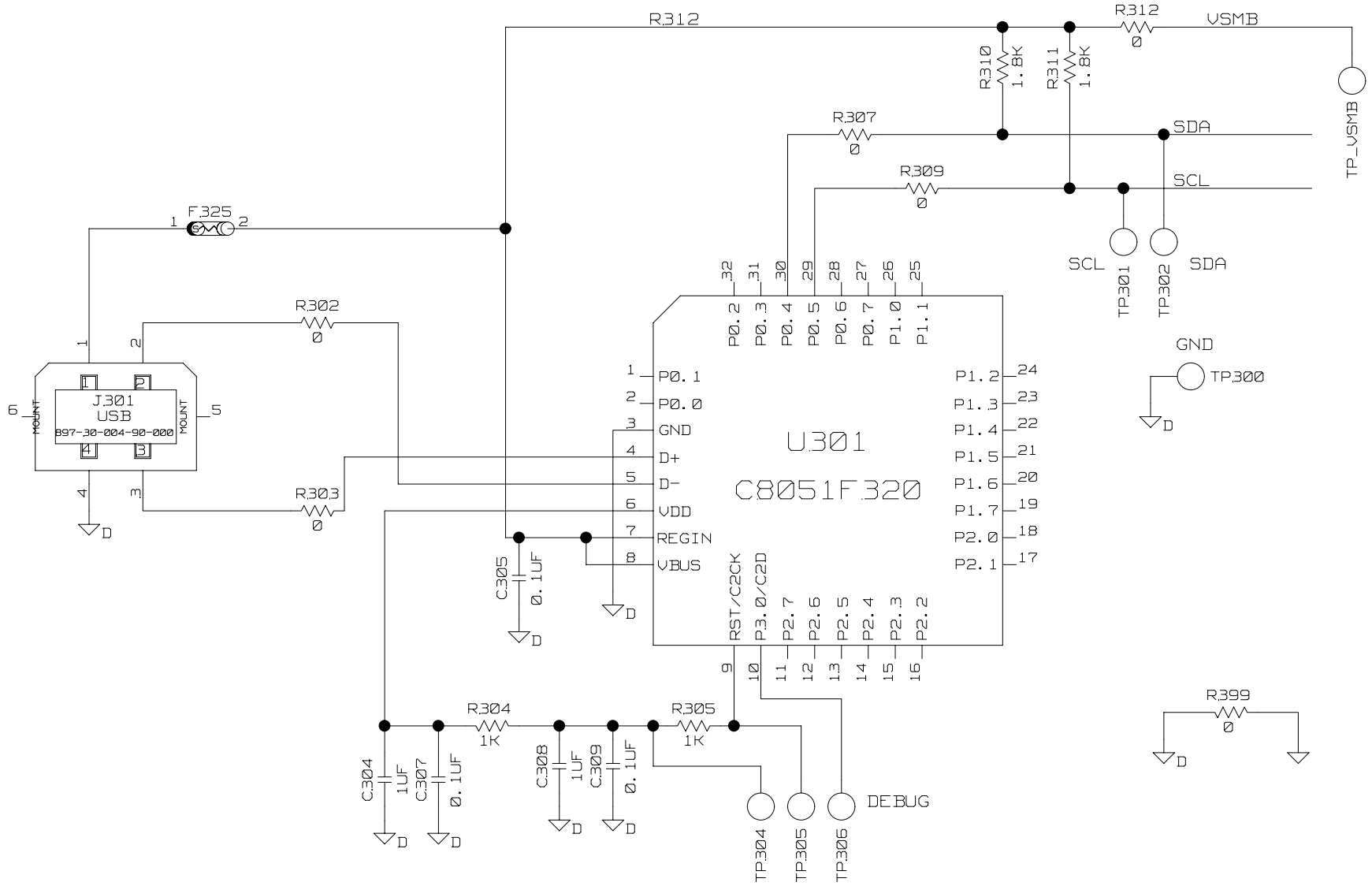

FIGURE 11. ISL9519EVAL1Z SCHEMATIC

# ISL9519EVAL1Z Schematics (Continued)



**FIGURE 12. ISL9519EVAL1Z SCHEMATIC (USB - SMBUS INTERFACE)**

ISL9519EVAL1Z Layout

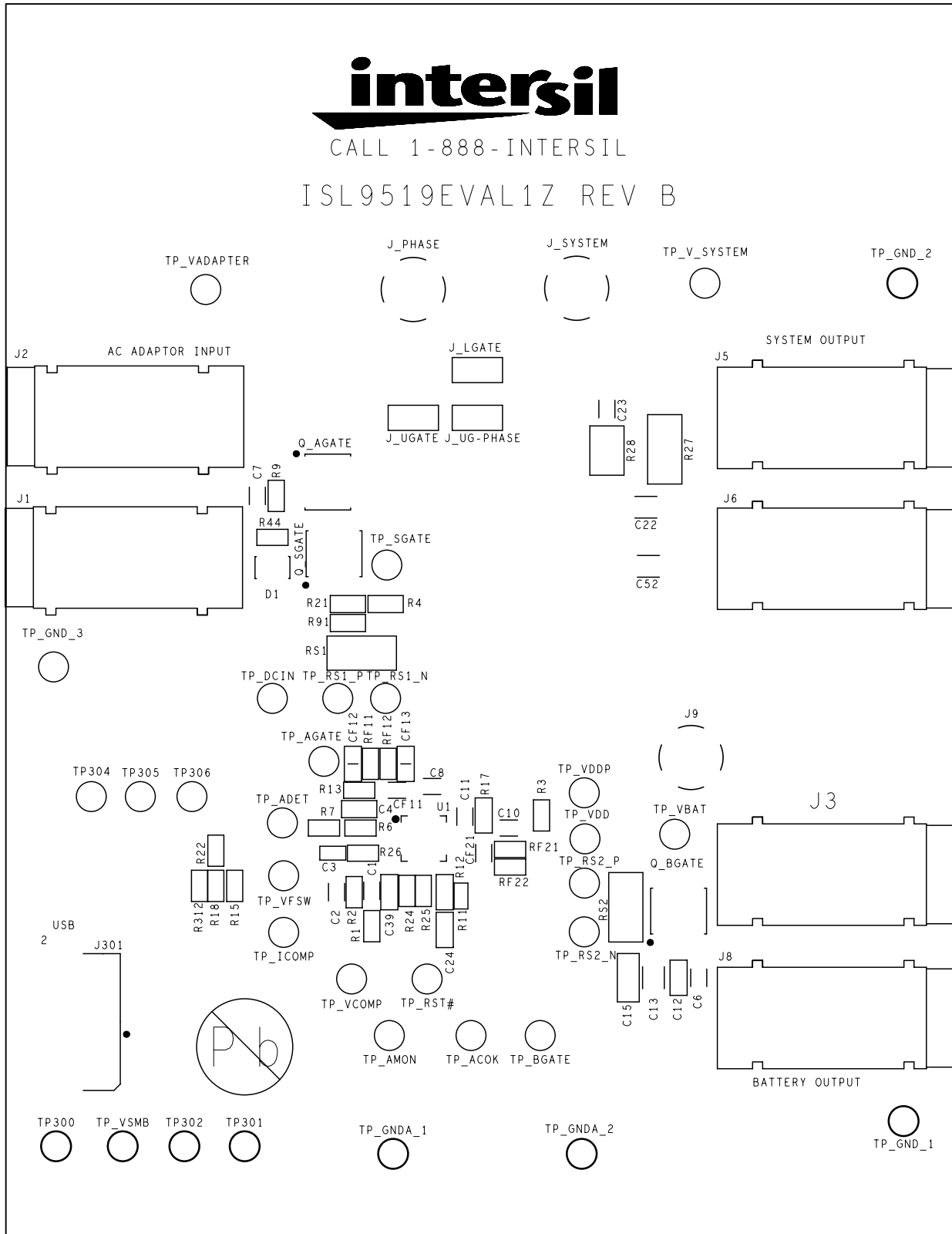

FIGURE 13. ISL9519EVAL1Z REV B TOP SILK SCREEN

ISL9519EVAL1Z Layout (Continued)

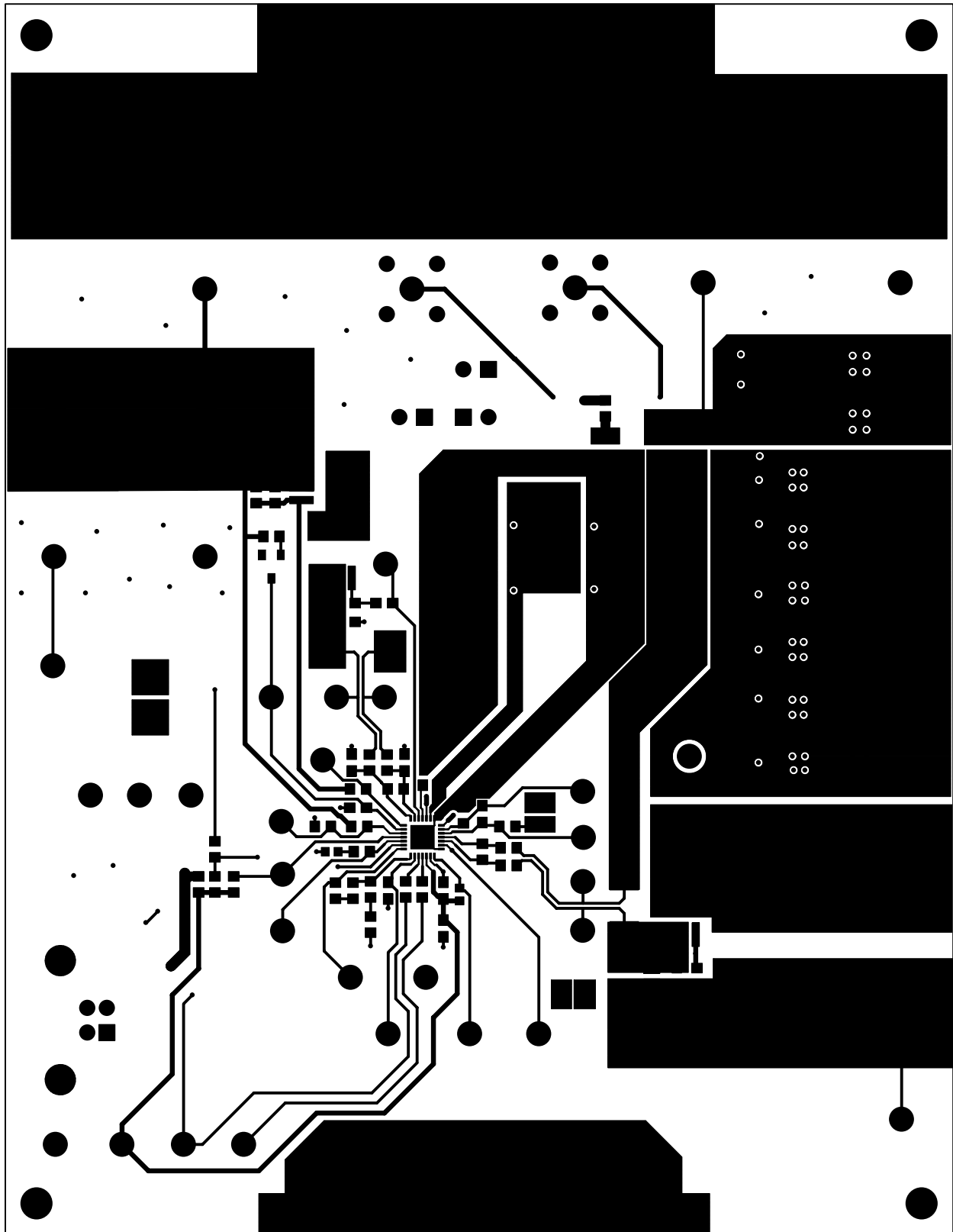

FIGURE 14. ISL9519EVAL1Z REV B TOP LAYER COPPER

ISL9519EVAL1Z Layout (Continued)

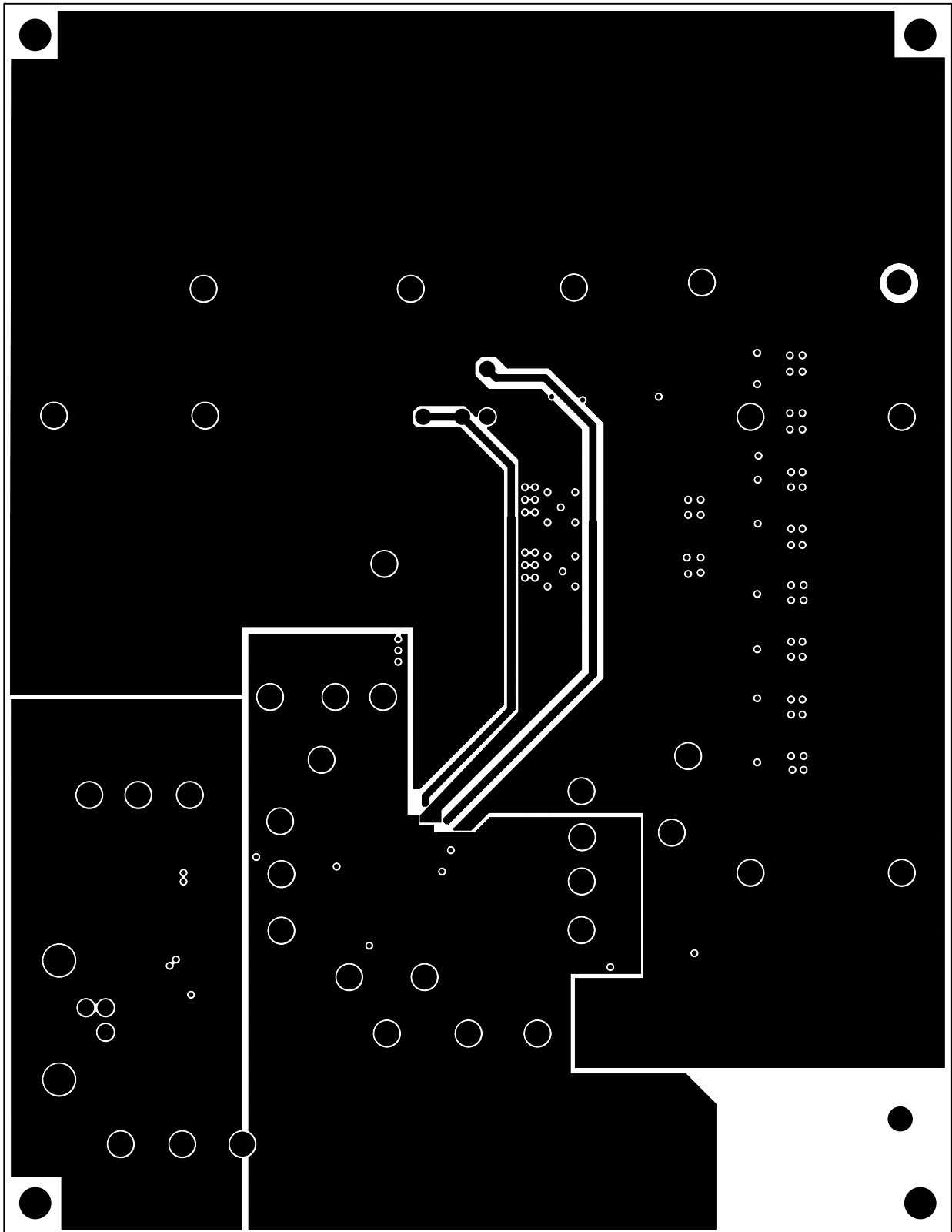

FIGURE 15. ISL9519EVAL1Z REV B LAYER 2 COPPER (VIEWED FROM THE TOP)

ISL9519EVAL1Z Layout (Continued)

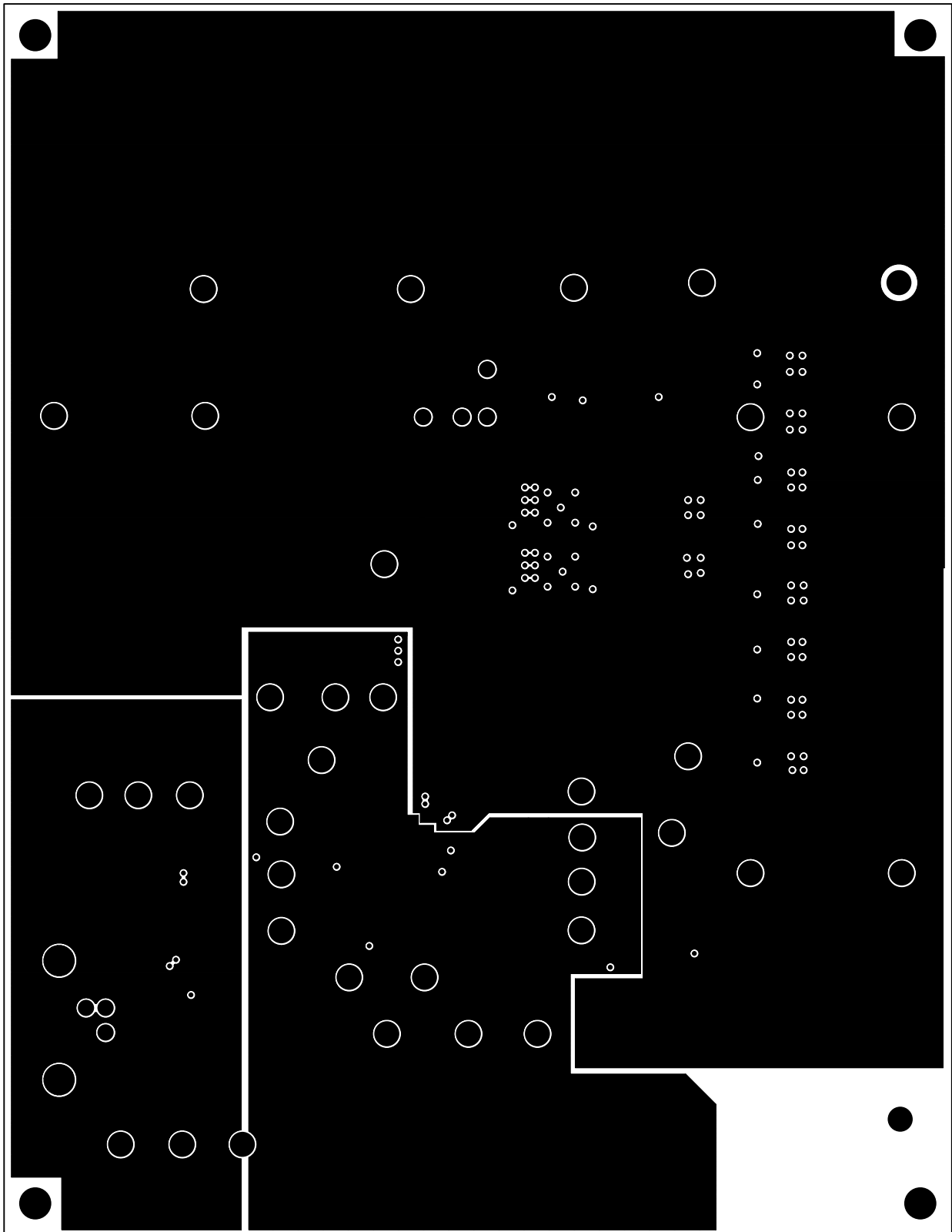
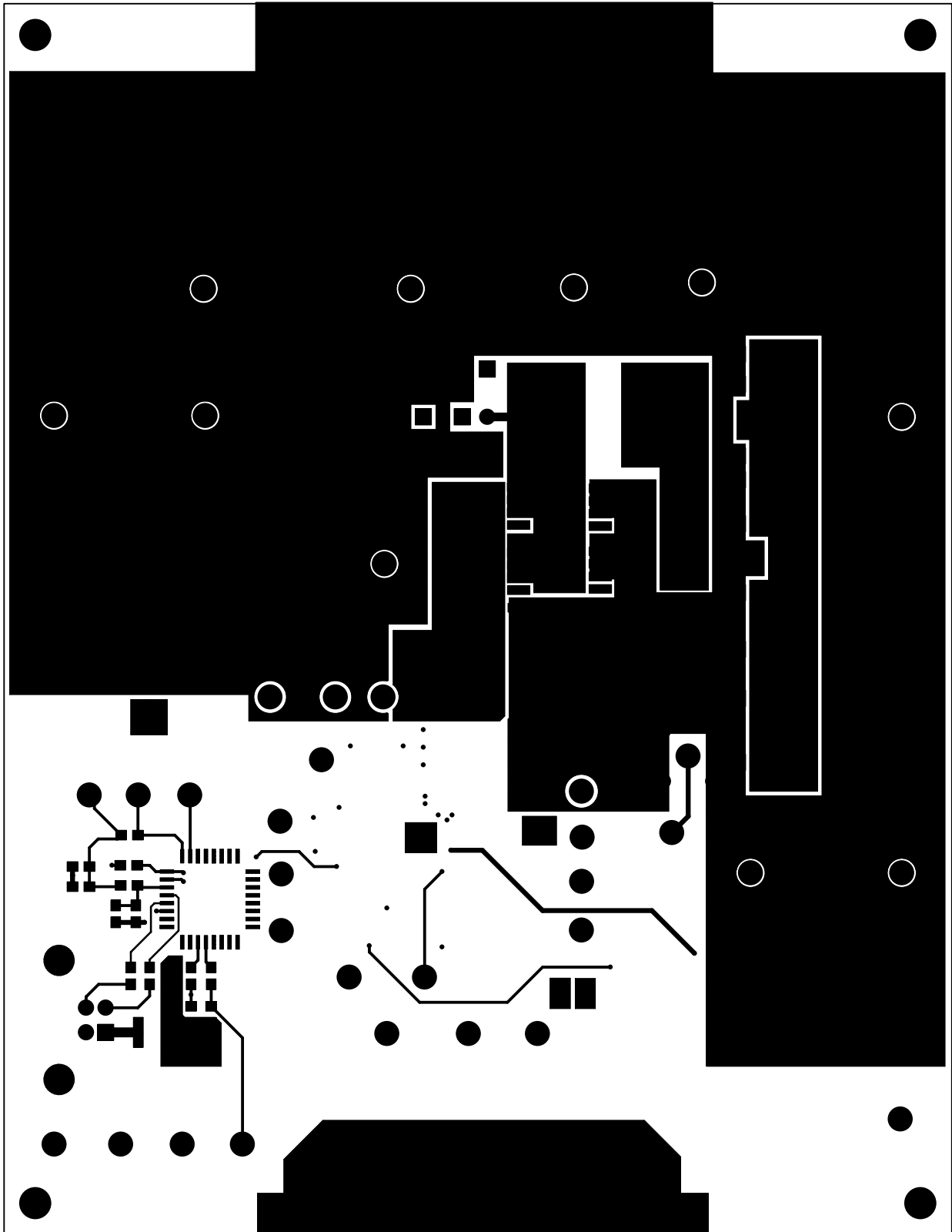

FIGURE 16. ISL9519EVAL1Z REV B LAYER 3 COPPER (TOP VIEW)

**ISL9519EVAL1Z Layout** (Continued)



**FIGURE 17. ISL9519EVAL1Z REV B BOTTOM COPPER (IF VIEWED FROM THE TOP TO ALIGN WITH OTHER LAYERS)**

ISL9519EVAL1Z Layout (Continued)

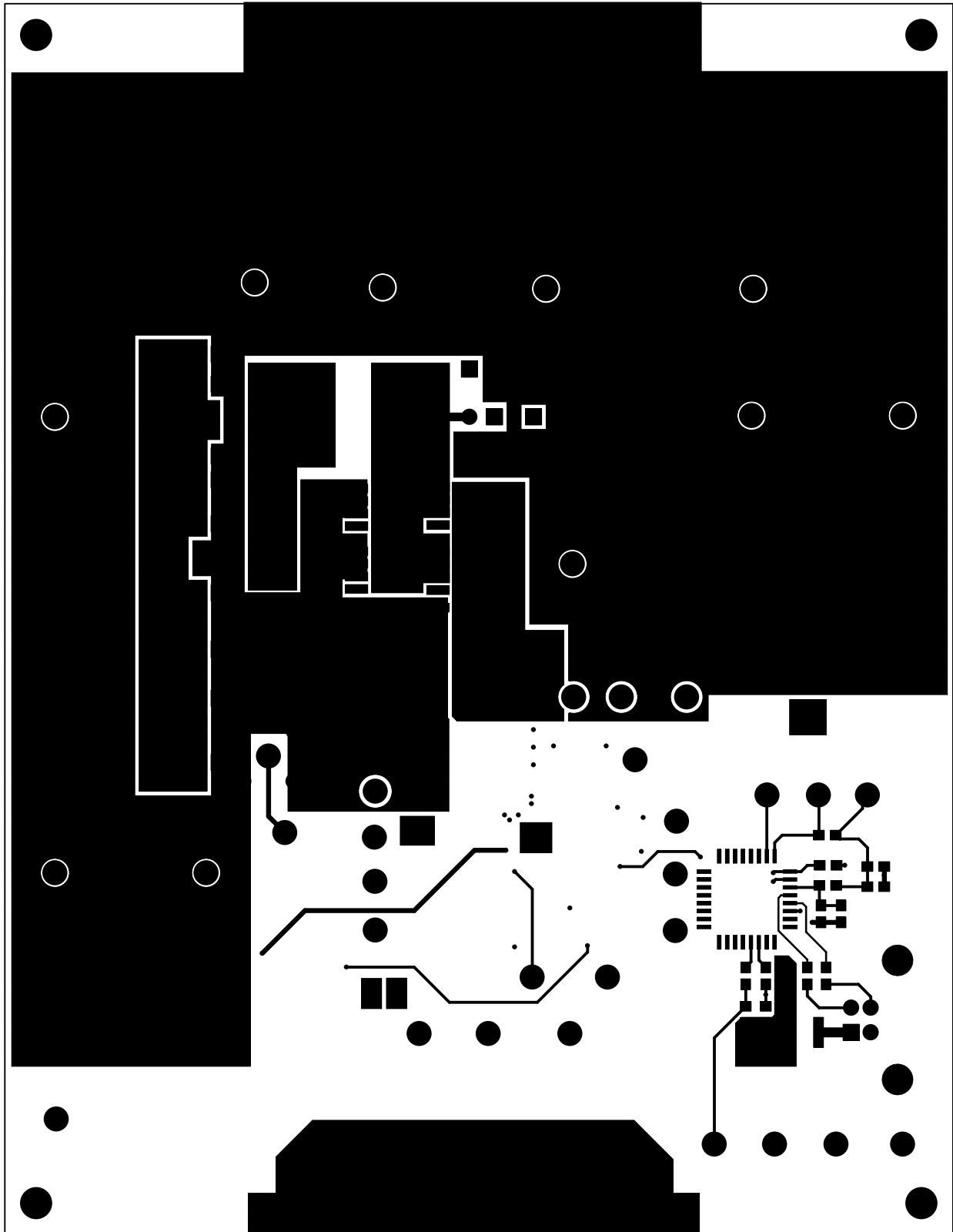

FIGURE 18. ISL9519EVAL1Z REV B BOTTOM COPPER (BOTTOM VIEW)

ISL9519EVAL1Z Layout (Continued)

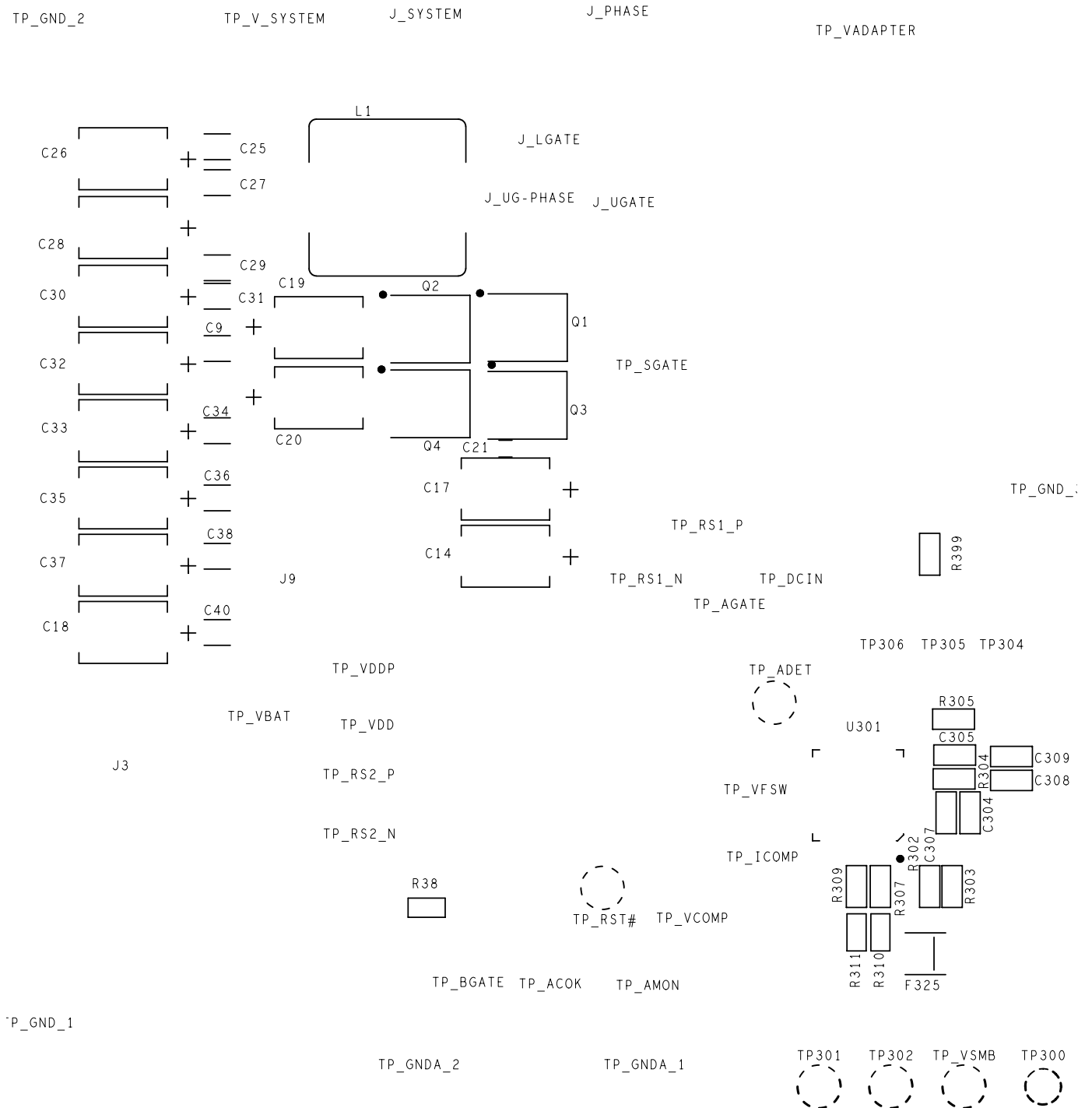

FIGURE 19. ISL9519EVAL1Z REV B BOTTOM SILK SCREEN

## Application Note 1562

### ISL9519EVAL1Z Bill of Materials

PART NUMBER	REF DES	VALUE	TOL.	MANUFACTURER	DESCRIPTION
H1045-00471-50V5	C1	470pF	5%	GENERIC	Multilayer Cap
H1045-00105-6R3V10	C10, C11	1μF	10%	GENERIC	Multilayer Cap
H1065-00106-25V20	C15	10μF	20%	GENERIC	Multilayer Cap
H1045-00102-50V5	C2, C6, C23	1000pF	5%	GENERIC	Multilayer Cap
H1044-OPEN	C21	OPEN	OPEN	GENERIC	Multilayer Cap
H1044-00104-25V10	C3	0.1μF	10%	GENERIC	Multilayer Cap
H1045-00105-6R3V10	CF21	1μF	10%	GENERIC	Multilayer Cap
H1045-00104-25V10	C4, C5, C7, C12, C24, C39, CF12, CF13	0.1μF	10%	GENERIC	Multilayer Cap
H1045-00224-25V20	C8	0.22μF	20%	GENERIC	Multilayer Cap
H1045-00473-25V10	CF11	0.047μF	10%	GENERIC	Multilayer Cap
BAT54	D1			DIODES	30V Schottky Diode
68000-236	J_LGATE, J_UGATE, J_UG-PHASE			FCI	2 Pin Header 2.54mm (0.100) Pitch
164-6218	J1, J6, J8			MOUSER	Single Point RA PCB Mount (Black)
164-6219	J2, J3, J5			MOUSER	Single Point RA PCB Mount (Red)
897-30-004-90-000	J301			MIL-MAX	Type B Receptacle USB Connector
131-5031-00	J9, J_PHASE, J_SYSTEM			TEKTRONIX	Scope Probe Test Point PCB Mount
FDS4465	Q_BGATE			Fairchild	30V to 7.4A P-Channel MOSFET
SI4835BDY	Q_AGATE, Q_SGATE			Siliconix	30V to 7.4A P-Channel MOSFET
H2505-03001-1/16WR1	R1	3k	0.10 %	GENERIC	Metal Film Chip Resistor
H2510-01002-1/16W1	R11	10k	1%	GENERIC	Thick Film Chip Resistor
H2511-01001-1/16W1	R15	1k	1%	GENERIC	Thick Film Chip Resistor
H2511-004R7-1/16W5	R17	4.7	5%	GENERIC	Thick Film Chip Resistor
H2505-05602-1/16WR1	R2	56k	0.10 %	GENERIC	Metal Film Chip Resistor
H2520-00R00-1/2W5	R27	0	5%	GENERIC	Thick Film Chip Resistor
H2514-01000-1/4W5	R28	100	5%	GENERIC	Thick Film Chip Resistor
H2511-00R00-1/16W1	R3, R24-R26, R38, RF22, R312	0	1%	GENERIC	Thick Film Chip Resistor
H2511-01003-1/16W1	R4, R12, R21, R91	100k	1%	GENERIC	Thick Film Chip Resistor
H2511-00330-1/16W5	R44	33	5%	GENERIC	Thick Film Chip Resistor
H2511-02702-1/16W5	R6	27k	5%	GENERIC	Thick Film Chip Resistor
H2505-01002-1/16WR1	R7, R18, R22	10k	0.10 %	GENERIC	Metal Film Chip Resistor
H2511-01003-1/10W5	R9, R13	100k	5%	GENERIC	Thick Film Chip Resistor
H2511-00100-1/16W1	RF11, RF12	10	1%	GENERIC	Thick Film Chip Resistor
H2511-002R2-1/16W5	RF21	2.2	5%	GENERIC	Thick Film Chip Resistor
LRC-LRF2010-01-R020-F	RS1	0.02	1%	IRC	LRC/LRF Series Chip Resistor
LRC-LRF2010LF-01-R010-F	RS2	0.01	1%	IRC	LRC/LRF Series Chip Resistor (Pb-free)

## Application Note 1562

### ISL9519EVAL1Z Bill of Materials (Continued)

PART NUMBER	REF DES	VALUE	TOL.	MANUFACTURER	DESCRIPTION
5009	TP_ACIN, TP_ACOK, TP_AMON, TP_BMON, TP_VFSW, TP_ICOMP, TP_VCOMP, TP_SMB_RST_N			KEYSTONE	Compact Yellow Test Point 0.070 Pad 0.041 Thole
5006	TP_DCIN, TP_AGATE, TP_BGATE, TP_GND_1- TP_GND_3, TP_RS1_N, TP_RS2_N, TP_SGATE, TP_GNDA_1, TP_GNDA_2			KEYSTONE	Compact Black Test Point 0.070 Pad 0.041 Thole
5005	TP_VDD, TP_VBAT, TP_VDDP, TP_VADAPTER, TP_V_SYSTEM			KEYSTONE	Compact Red Test Point 0.070 Pad 0.041 Thole
5001	TP300			KEYSTONE	Miniature Black Test Point 0.100 Pad 0.040 Thole
5007	TP301-TP306, TP_RS1_P, TP_RS2_P			KEYSTONE	Compact White Test Point 0.070 Pad 0.041 Thole
ISL9519HRTZ	U1			INTERSIL	Narrow VDC Regulator/Charger (Pb-free)
<b>Components below are on the bottom of the board</b>					
20TQC47M	C14, C17-C20, C26, C28, C30, C32, C33, C35, C37	47µF	20%	SANYO	TQC Series Hi-Volt Low ESR Capacitor
H1045-00105-6R3V10	C304, C308	1µF	10%	GENERIC	Multilayer Cap
H1045-00104-25V10	C305, C307, C309	0.1µF	10%	GENERIC	Multilayer Cap
H1046-00105-25V10	C9, C13, C22, C25, C27, C29, C31, C34, C36, C38, C40, C52	1µF	10%	GENERIC	Multilayer Cap
MICROSMD050F	F325	?	?	RAYCHEM-TYCO	PolySwitch SM Resettable Fuse
IHLP-5050CE-01-4R7M	L1	4.7µH	20%	VISHAY	13mm SMD Inductor
RJK0305	Q1-Q4			HITACHI	N-Channel Power MOSFET
H2511-00R00-1/16W1	R302, R303, R307, R309, R399	0	1%	GENERIC	Thick Film Chip Resistor
H2511-01001-1/16W1	R304, R305	1k	1%	GENERIC	Thick Film Chip Resistor
H2511-01801-1/16W5	R310, R311	1.8k	5%	GENERIC	Thick Film Chip Resistor
C8051F320-GQ/PROG- REV.02	U301			SILICON LABRATORIES	General Purpose MicroControllers

*Intersil Corporation reserves the right to make changes in circuit design, software and/or specifications at any time without notice. Accordingly, the reader is cautioned to verify that the Application Note or Technical Brief is current before proceeding.*

For information regarding Intersil Corporation and its products, see [www.intersil.com](http://www.intersil.com)

# AMEYA360

## Components Supply Platform

Authorized Distribution Brand :



Website :

Welcome to visit [www.ameya360.com](http://www.ameya360.com)

Contact Us :

➤ Address :

401 Building No.5, JiuGe Business Center, Lane 2301, Yishan Rd  
Minhang District, Shanghai , China

➤ Sales :

Direct +86 (21) 6401-6692

Email [amall@ameya360.com](mailto:amall@ameya360.com)

QQ 800077892

Skype [ameyasales1](#) [ameyasales2](#)

➤ Customer Service :

Email [service@ameya360.com](mailto:service@ameya360.com)

➤ Partnership :

Tel +86 (21) 64016692-8333

Email [mkt@ameya360.com](mailto:mkt@ameya360.com)