

Evaluation Board for CS4382A

Features

- ◆ Demonstrates recommended layout and grounding arrangements
- ◆ CS8416 receives S/PDIF, & EIAJ-340 compatible digital audio
- ◆ Headers for external audio input for either PCM or DSD®
- ◆ Requires only a digital signal source and Power supplies for a complete digital-to-analog converter system

Description

The CDB4382A evaluation board is an excellent means for quickly evaluating the CS4382A 24-bit, 48-pin, 8-channel D/A converter. Evaluation requires an analog signal analyzer, a digital signal source, a PC for controlling the CS4382A (only required for control port mode), and a power supply. Analog line-level outputs are provided via RCA phono jacks.

The CS8416 digital audio receiver IC provides the system timing necessary to operate the digital-to-analog converter and will accept S/PDIF and EIAJ-340-compatible audio data. The evaluation board may also be configured to accept external timing and data signals for operation in a user application during system development.

ORDERING INFORMATION

CDB4382A

Evaluation Board

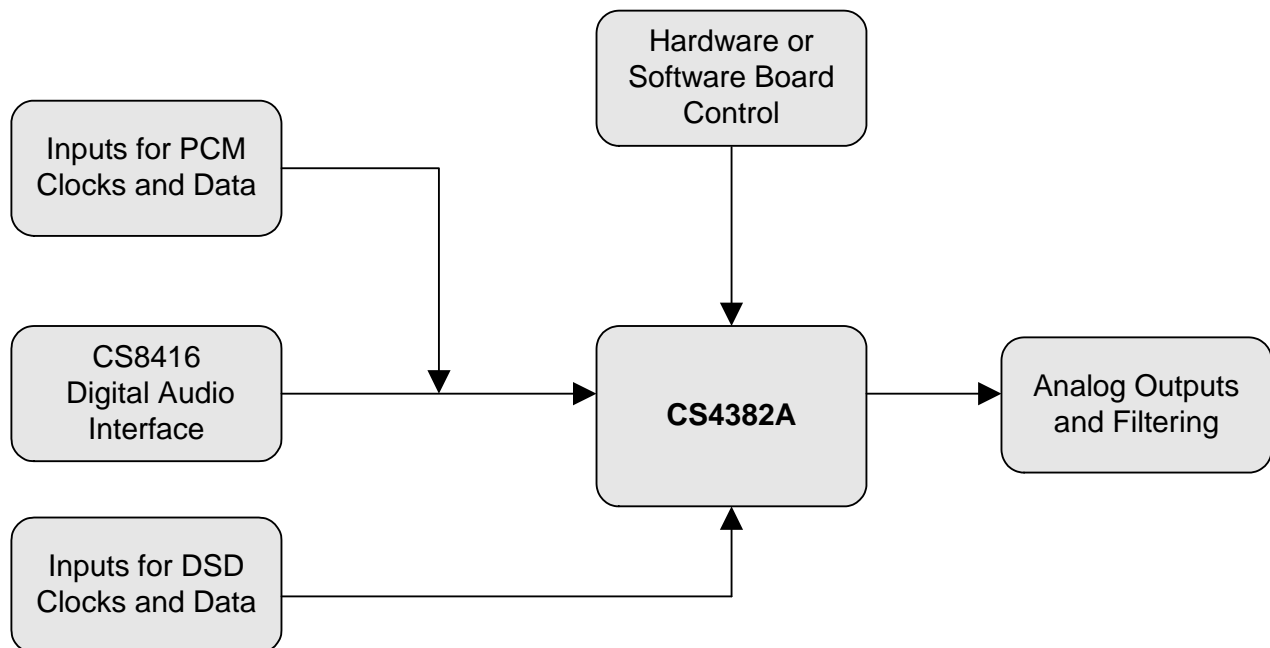

TABLE OF CONTENTS

1. CS4382A DIGITAL-TO-ANALOG CONVERTER	4
2. CS8416 DIGITAL AUDIO RECEIVER	4
3. INPUT FOR CLOCKS AND DATA	4
4. INPUT FOR CONTROL DATA	4
5. POWER SUPPLY CIRCUITRY	5
6. GROUNDING AND POWER SUPPLY DECOUPLING	5
7. ANALOG OUTPUT FILTERING	5
8. PERFORMANCE PLOTS	7
9. SCHEMATICS	17
10. REVISION HISTORY	30

LIST OF FIGURES

Figure 1.FFT (48 kHz, 0 dB)	7
Figure 2.FFT (48 kHz, -60 dB)	7
Figure 3.FFT (48 kHz, No Input)	7
Figure 4.FFT (48 kHz Out-of-Band, No Input)	7
Figure 5.FFT (48 kHz, -60 dB Wideband)	8
Figure 6.FFT (IMD 48 kHz)	8
Figure 7.48 kHz, THD+N vs. Input Freq	8
Figure 8.48 kHz, THD+N vs. Level	8
Figure 9.48 kHz, Fade-to-Noise Linearity	8
Figure 10.48 kHz, Frequency Response	8
Figure 11.48 kHz, Crosstalk	9
Figure 12.48 kHz, Impulse Response	9
Figure 13.48 kHz, Impulse Prefilter	9
Figure 14.Dynamic Range 48 kHz	10
Figure 15.FFT (96 kHz, 0 dB)	10
Figure 16.FFT (96 kHz, -60 dB)	10
Figure 17.FFT (96 kHz, No Input)	11
Figure 18.FFT (96 kHz Out-of-Band, No Input)	11
Figure 19.FFT (96 kHz, -60 dB Wideband)	11
Figure 20.FFT (IMD 96 kHz)	11
Figure 21.96 kHz, THD+N vs. Input Freq	11
Figure 22.96 kHz, THD+N vs. Level	11
Figure 23.96 kHz, Fade-to-Noise Linearity	12
Figure 24.96 kHz, Frequency Response	12
Figure 25.96 kHz, Crosstalk	12
Figure 26.96 kHz, Impulse Response	12
Figure 27.96 kHz, Impulse Prefilter	12
Figure 28.Dynamic Range 96 kHz	13
Figure 29.FFT (192 kHz, 0 dB)	13
Figure 30.FFT (192 kHz, -60 dB)	13
Figure 31.FFT (192 kHz, No Input)	14
Figure 32.FFT (192 kHz Out-of-Band, No Input)	14
Figure 33.FFT (192 kHz, -60 dB Wideband)	14
Figure 34.FFT (IMD 192 kHz)	14
Figure 35.192 kHz, THD+N vs. Input Freq	14
Figure 36.192 kHz, THD+N vs. Level	14
Figure 37.192 kHz, Fade-to-Noise Linearity	15
Figure 38.192 kHz, Frequency Response	15
Figure 39.192 kHz, Crosstalk	15

Figure 40.192 kHz, Impulse Response	15
Figure 41.192 kHz, Impulse Prefilter	15
Figure 42.Dynamic Range 192 kHz	16
Figure 43.System Block Diagram and Signal Flow	17
Figure 44.CS4382A	18
Figure 45.Analog Output Pairs 1 & 2	19
Figure 46.Analog Output Pairs 3 & 4	20
Figure 47.Mute Circuits	21
Figure 48.CS8416 S/PDIF Input	22
Figure 49.PCM Input Header and Muxing	23
Figure 50.DSD Input Header	24
Figure 51.Control Input	25
Figure 52.Power Inputs	26
Figure 53.Silkscreen Top	27
Figure 54.Top Side	28
Figure 55.Bottom Side	29

LIST OF TABLES

Table 1. System Connections	5
Table 2. CDB4382A Jumper Settings	6

CDB4382A SYSTEM OVERVIEW

The CDB4382A evaluation board is an excellent means of quickly evaluating the CS4382A. The CS8416 digital audio interface receiver provides an easy interface to digital audio signal sources including the majority of digital audio test equipment. The evaluation board also allows the user to supply external PCM or DSD clocks and data through PCB headers for system development.

The CDB4382A uses the CDB4385 as a base PCB board. For this reason, there may be additional circuitry on board which is not populated as it has no function for this device.

The CDB4382A schematic has been partitioned into the nine schematics shown in [Figures 44](#) through [52](#). Each partitioned schematic is represented in the system diagram shown in [Figure 43](#). Notice that the system diagram also includes the interconnections between the partitioned schematics.

1. CS4382A DIGITAL-TO-ANALOG CONVERTER

A description of the CS4382A is included in the CS4382A datasheet.

2. CS8416 DIGITAL AUDIO RECEIVER

The system receives and decodes the standard S/PDIF data format using a CS8416 digital audio receiver ([Figure 48](#)). The outputs of the CS8416 include a serial bit clock, serial data, left-right clock, and a 128/256 Fs master clock. The CS8416 data format is fixed to I²S. The operation of the CS8416 and a discussion of the digital audio interface are included in the CS8416 datasheet.

The evaluation board has been designed such that the input can be either optical or coaxial (See [Figure 48](#)). However, both inputs cannot be driven simultaneously.

Switch position 7 of S1 sets the output MCLK-to-LRCK ratio of the CS8416. This switch should be set to 256 (closed) for inputs $F_s \leq 96$ kHz and 128 (open) for $F_s \geq 64$ kHz. The 8416 must be manually reset using 'HW RST' (S2) or through the software when this switch is changed.

3. INPUT FOR CLOCKS AND DATA

The evaluation board has been designed to allow interfacing to external systems via headers J11 and J7. Header J11 allows the evaluation board to accept externally generated PCM clocks and data. The schematic for the clock/data input is shown in [Figure 49](#). Switch position 6 of S1 selects the source as either CS8416 (open) or header J11 (closed).

Header J7 allows the evaluation board to accept externally generated DSD data and clocks. The schematic for the clock/data input is shown in [Figure 50](#). A synchronous MCLK must still be provided via Header J11. Switch position 8 of S1 selects either PCM (open) or DSD (closed).

Please see the CS4382A datasheet for more information.

4. INPUT FOR CONTROL DATA

The evaluation board can be run in either a stand-alone mode or with a PC. Stand-alone mode uses the CS4382A in hardware mode and the mode pins are configured using switch positions 1 through 5 of S1. PC mode uses software to setup the CS4382A through I²C[®] using the PC's serial or USB ports. PC mode is automatically selected when the serial or USB port is attached and the CDB4382A software is running.

Header J15 offers the option for external input of RST and SPI[™]/I²C clocks and data. The board is set up at the factory to use the on-board microcontroller in conjunction with the supplied software. To use an external control

source, remove the shunts on J15 and place a ribbon cable so the signal lines are on the center row and the grounds are on the right side. R116 and R119 should be populated with 2 kΩ resistors when using an external I²C source that does not already provide pull-ups.

5. POWER SUPPLY CIRCUITRY

Power is supplied to the evaluation board by four binding posts: GND, +5V, +12V, and -12V (See [Figure 52](#)). The '+5V' terminal supplies VA and the rest of the +5 V circuitry on the board. The +3.3 V circuitry is powered from a regulator. The +2.5 V required for VD is also provided from an on-board regulator. The +5 V supply should be set within the recommended values for VA stated in the CS4382A datasheet.

WARNING: Refer to the CS4382A datasheet for maximum allowable voltage levels. Operation outside this range can cause permanent damage to the device.

6. GROUNDING AND POWER SUPPLY DECOUPLING

As with any high-performance converter, the CS4382A requires careful attention to power supply and grounding arrangements to optimize performance. [Figure 44](#) details the connections to the CS4382A and [Figures 53, 54, and 55](#) show the component placement and top and bottom layout. The decoupling capacitors are located as close to the CS4382A as possible. Extensive use of ground plane fill in the evaluation board yields large reductions in radiated noise.

7. ANALOG OUTPUT FILTERING

The analog output on the CDB4382A has been designed according to the CS4382A datasheet. This output circuit includes an active 2-pole, 50-kHz filter which uses the multiple-feedback topology.

CONNECTOR	INPUT/OUTPUT	SIGNAL PRESENT
+5V	Input	+ 5 V power
GND	Input	Ground connection from power supply
+12V	Input	+12 V positive supply for the on-board filtering
-12V	Input	-12 V negative supply for the on-board filtering
S/PDIF IN - J9	Input	Digital audio interface input via coax
S/PDIF IN - OPT1	Input	Digital audio interface input via optical
PCM INPUT - J11	Input	Input for master, serial, left/right clocks and serial data
DSD INPUT - J7	Input	Input for DSD serial clock and DSD data
OUTA1-B4	Output	RCA line level analog outputs

Table 1. System Connections

JUMPER / SWITCH	PURPOSE	POSITION	FUNCTION SELECTED
J15	Selects source of control data	*shunts on Left shunts removed	*Control from PC and on-board microcontroller External control input using center and right columns
J16	JTAG micro programming	-	Reserved for factory use only
S2	Resets CS8416 and CS4382A		The CS8416 must be reset if switch S1 is changed
S1	CS4382A mode settings M0-M4	1-5	Default: M0, M4 open (HI) M1, M2, M3 closed (LO)
	Sets clock source	6	Sets clock source for CS4382A *open = RX(CS8416), closed = $\overline{\text{EXT}}$ (J11)
	Sets MCLK ratio of CS8416	7	Selects 128x (open) or $\overline{256x}$ (*closed) MCLK/LRCK ratio output for CS8416
	Selects PCM or DSD mode	8	For PCM input set to *Open, for DSD set to Closed
*Default Factory Settings			

Table 2. CDB4382A Jumper Settings

8. PERFORMANCE PLOTS

The plots in the following section were achieved using an Audio Precision System 2700 and a randomly chosen production CDB4382A. In some cases the performance may be limited by the CDB4382A. All measurements were taken at room temp using the standard AP filter options (20 Hz to 22 kHz) with default board settings and nominal datasheet voltages applied unless otherwise noted.

The impulse response plots were taken both pre-and post filtering as the off-chip filter was degrading the performance at higher sample rates. The pre-filter impulse response plots were taken directly at the output pins of the DAC (with the analog filter still connected) to show the effect of the CDB's analog filtering on the impulse response (as the analog filtering adds its own signature to the impulse response of the DAC, and in the case of the higher sampling rates it was band-limiting it).

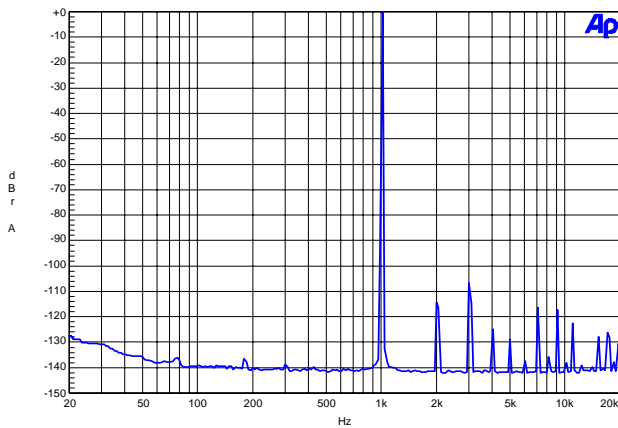

Figure 1. FFT (48 kHz, 0 dB)

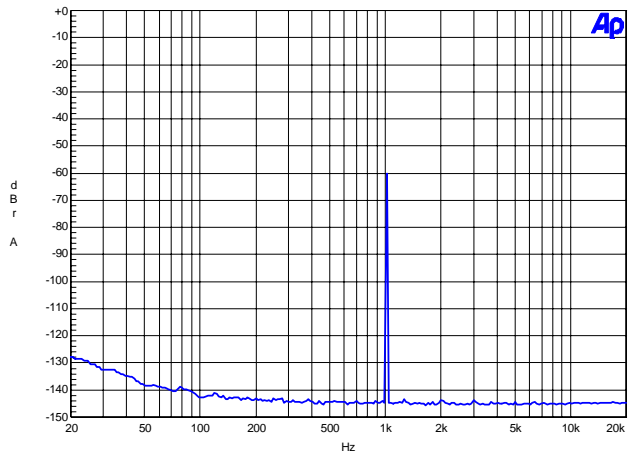

Figure 2. FFT (48 kHz, -60 dB)

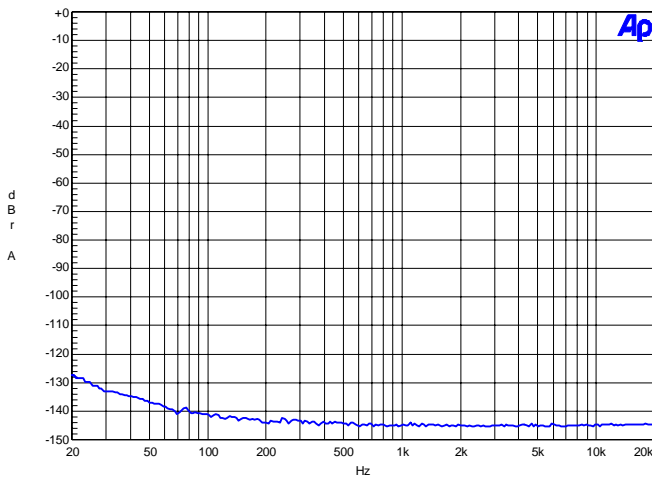

Figure 3. FFT (48 kHz, No Input)

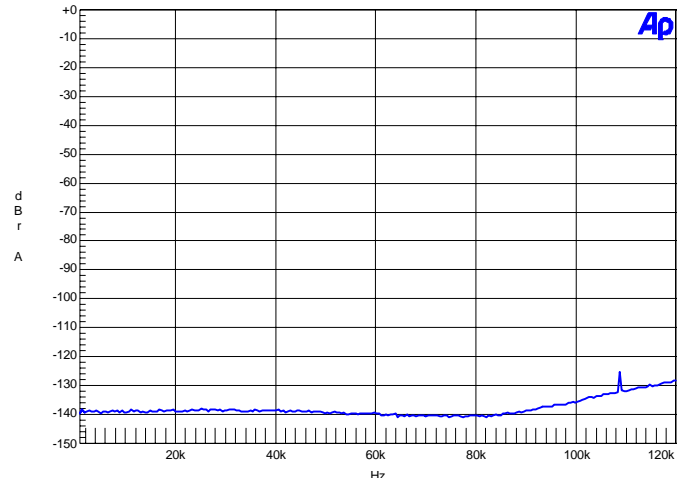
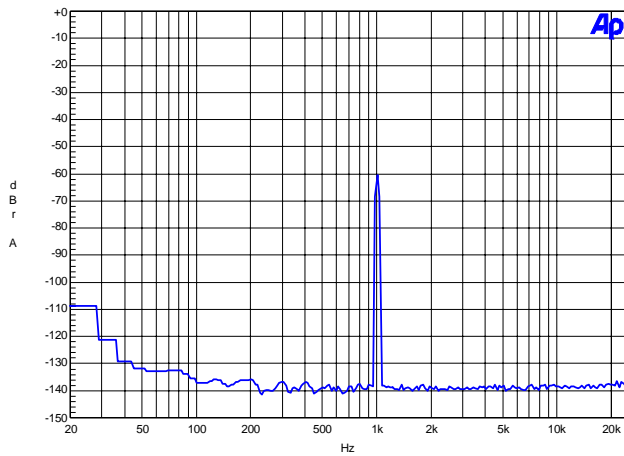
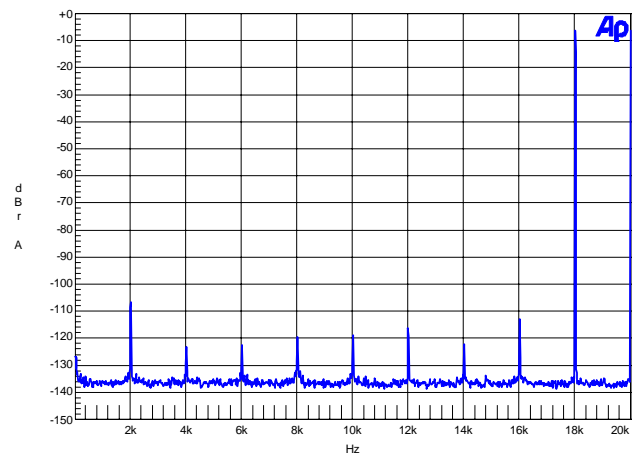
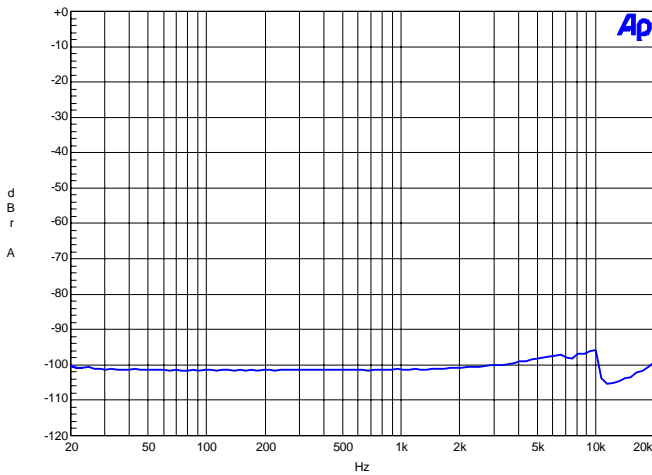
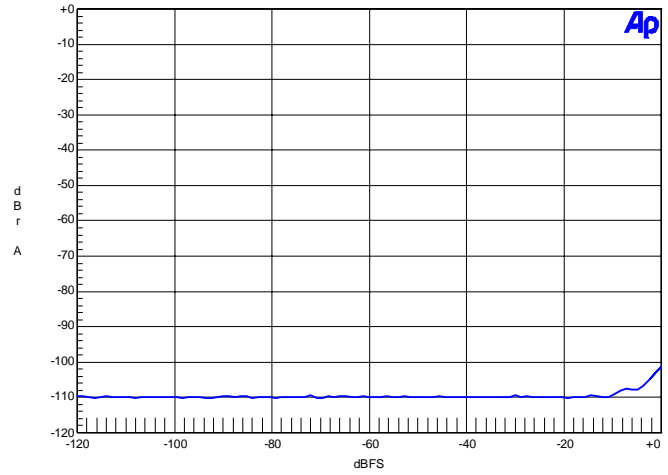
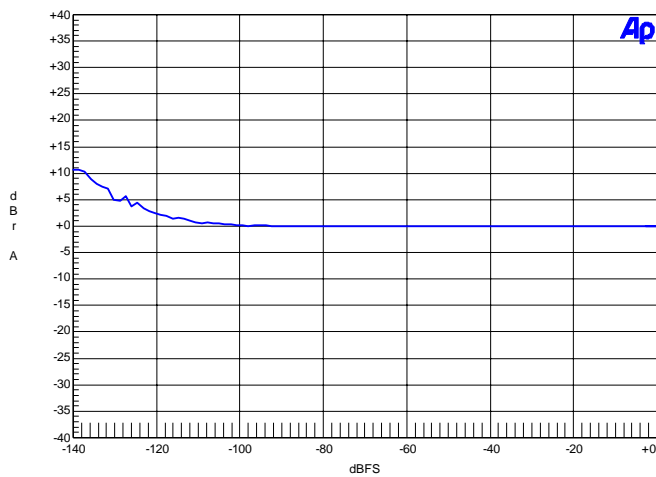
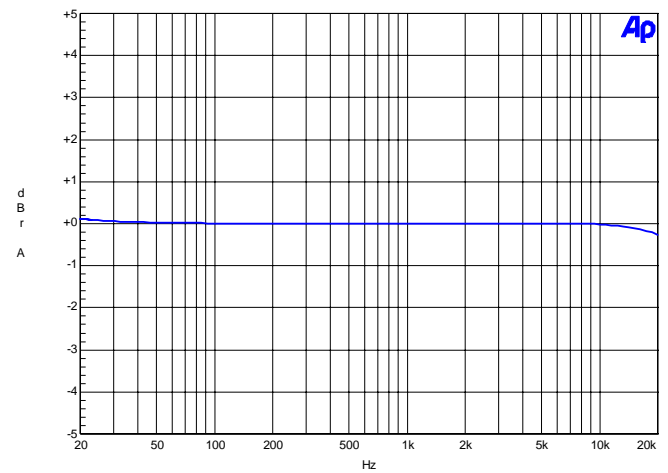
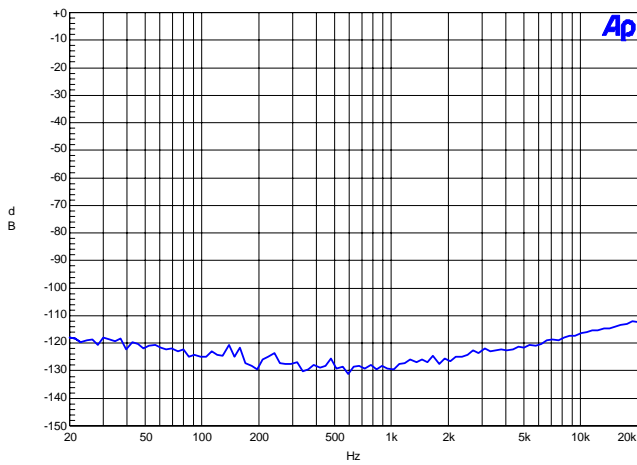
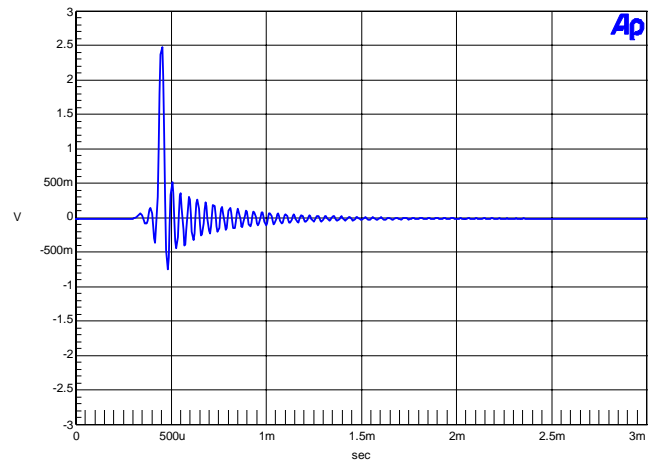
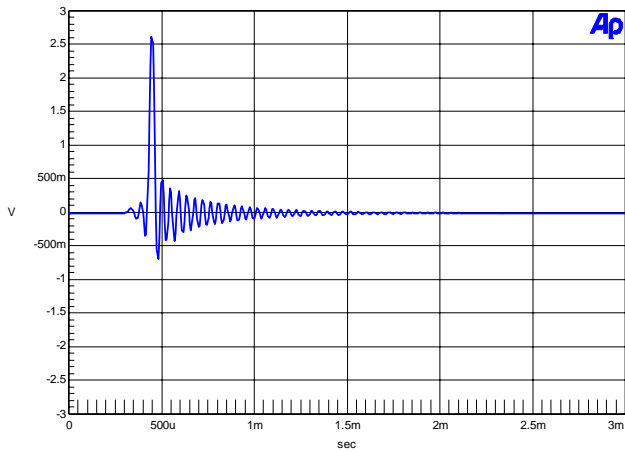

Figure 4. FFT (48 kHz Out-of-Band, No Input)

Figure 5. FFT (48 kHz, -60 dB Wideband)

Figure 6. FFT (IMD 48 kHz)

Figure 7. 48 kHz, THD+N vs. Input Freq

Figure 8. 48 kHz, THD+N vs. Level

Figure 9. 48 kHz, Fade-to-Noise Linearity

Figure 10. 48 kHz, Frequency Response

Figure 11. 48 kHz, Crosstalk

Figure 12. 48 kHz, Impulse Response

Figure 13. 48 kHz, Impulse Prefilter

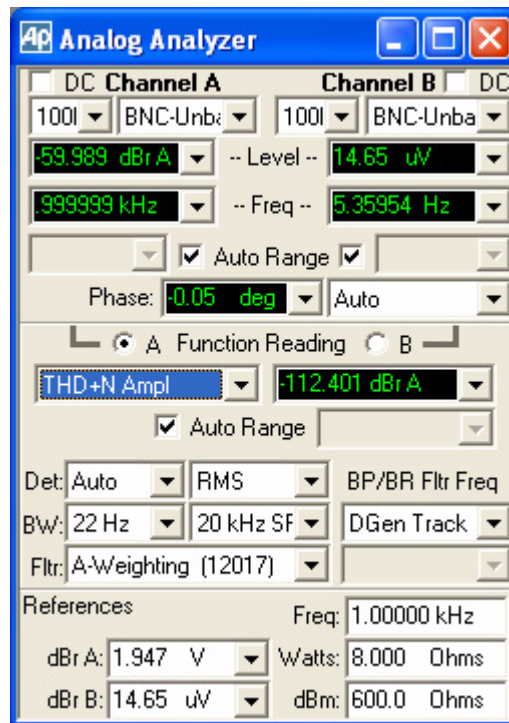

Figure 14. Dynamic Range 48 kHz

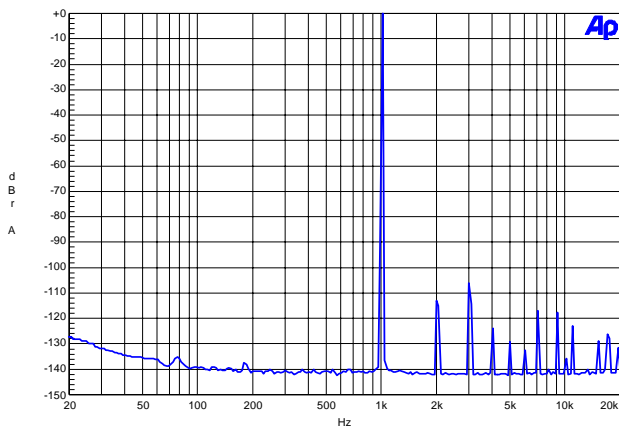

Figure 15. FFT (96 kHz, 0 dB)

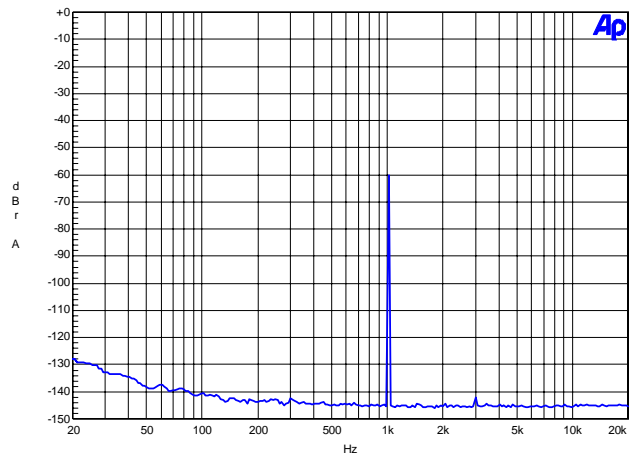
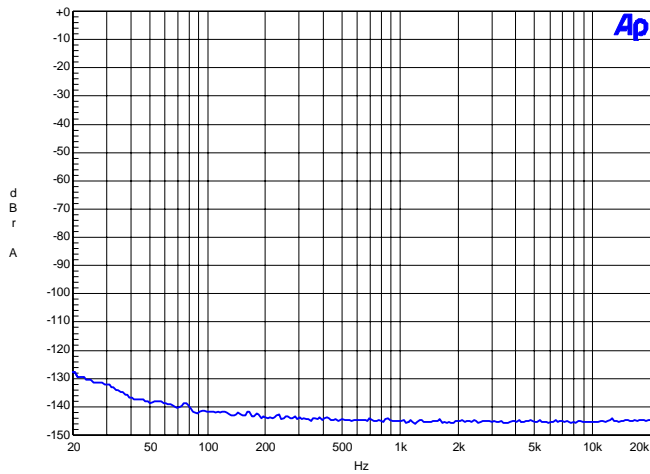
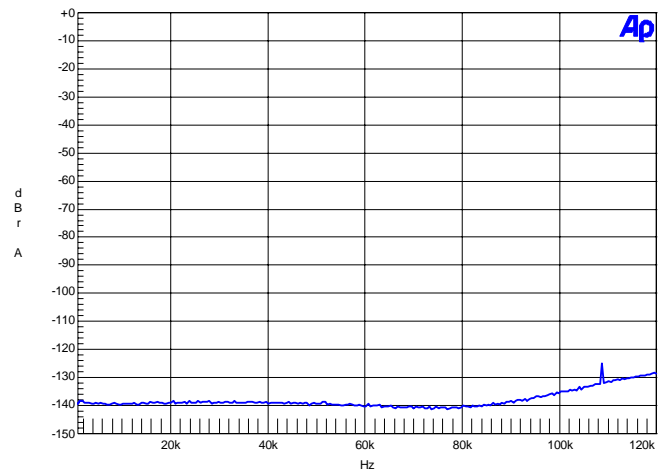
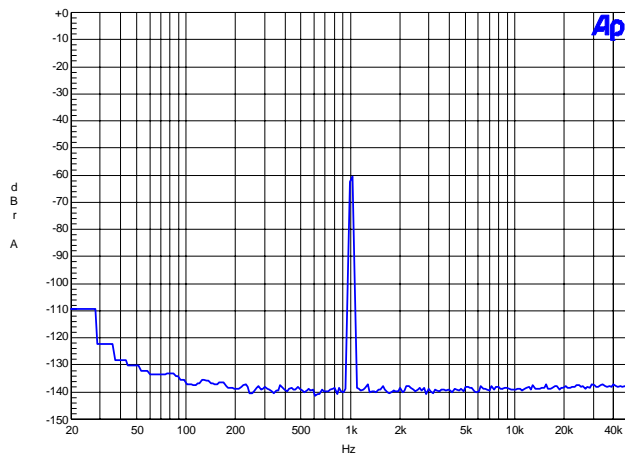
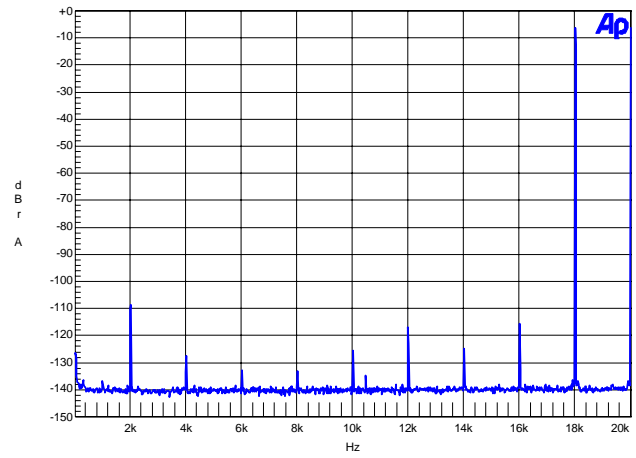
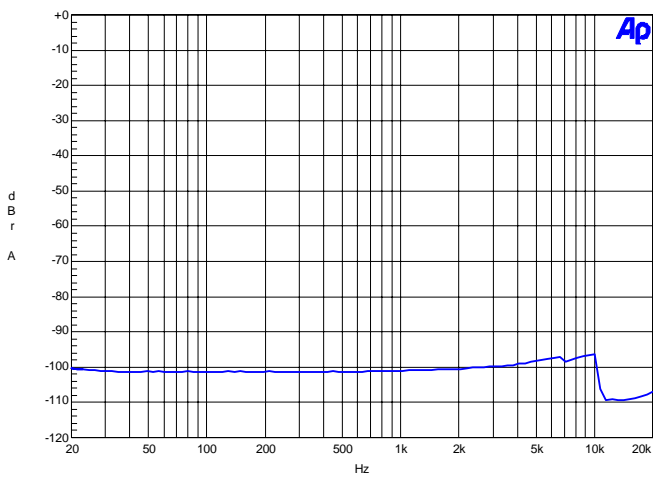
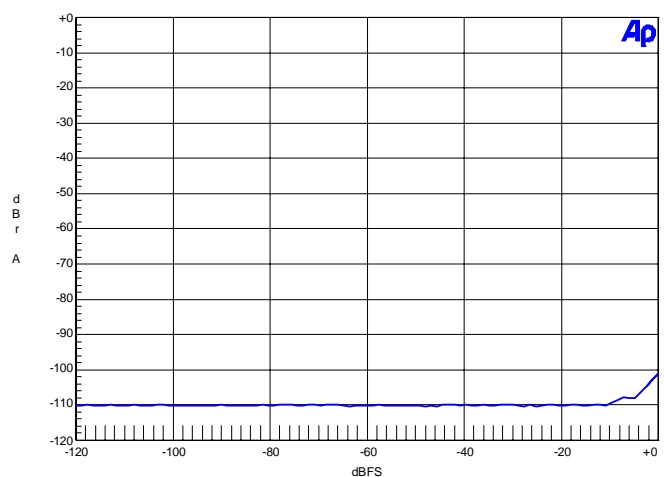
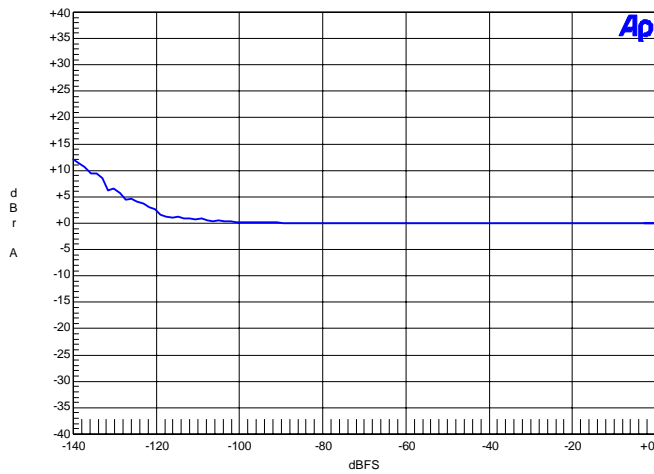
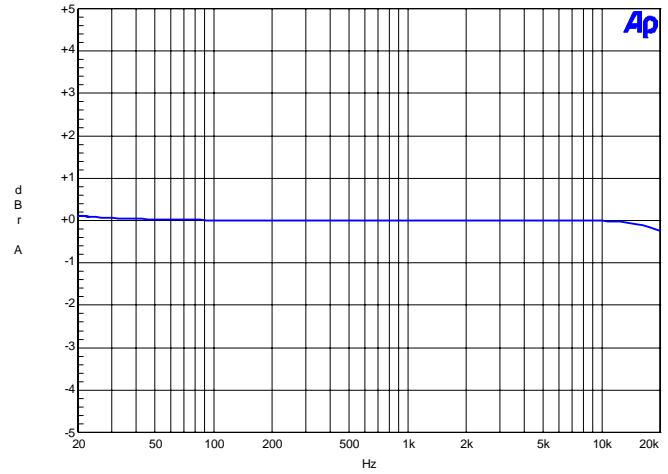
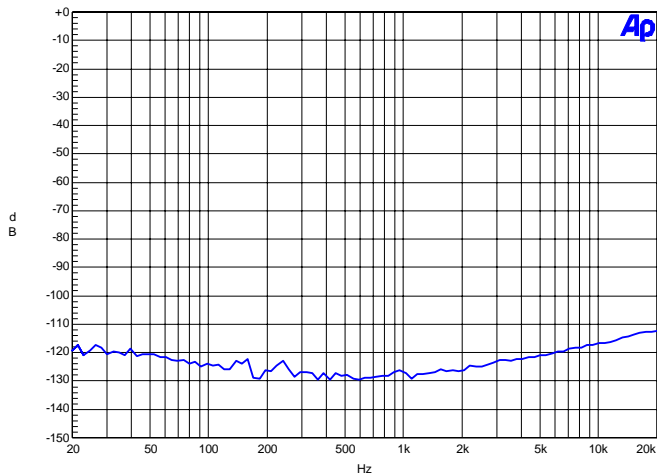
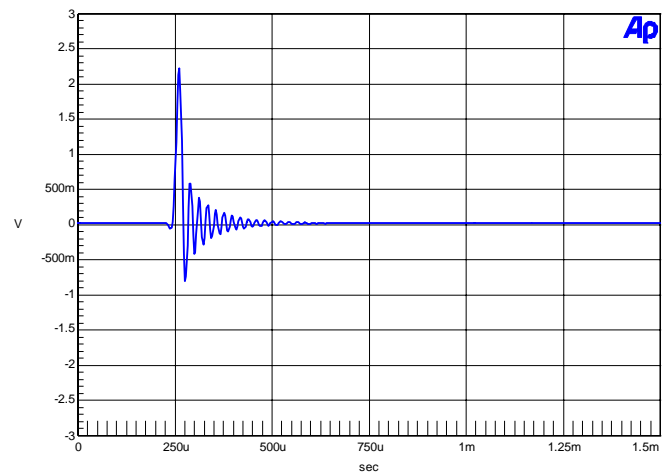
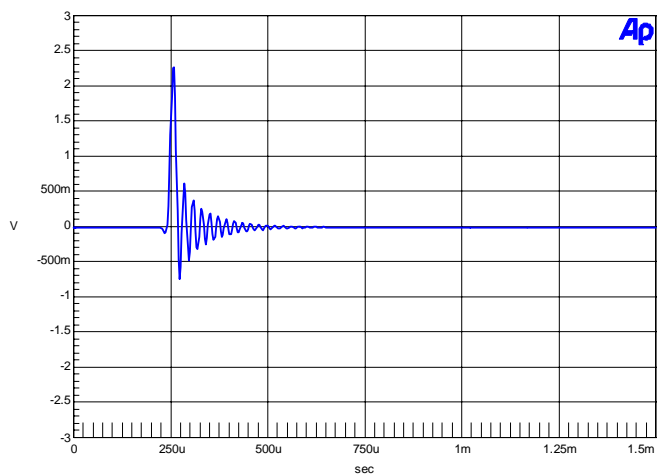
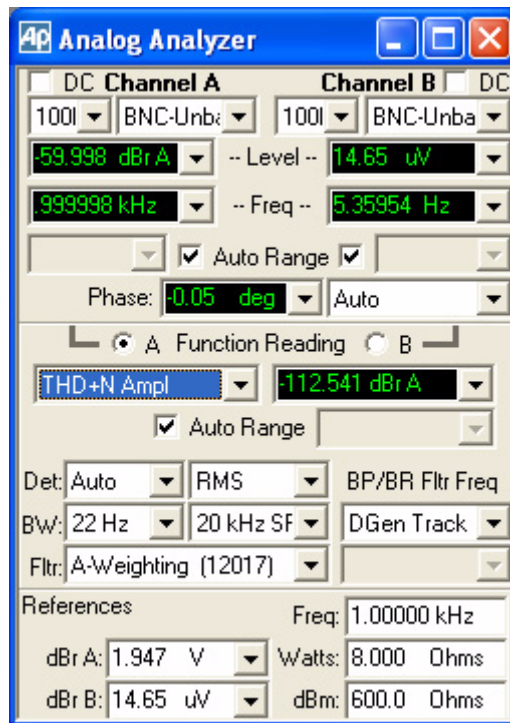
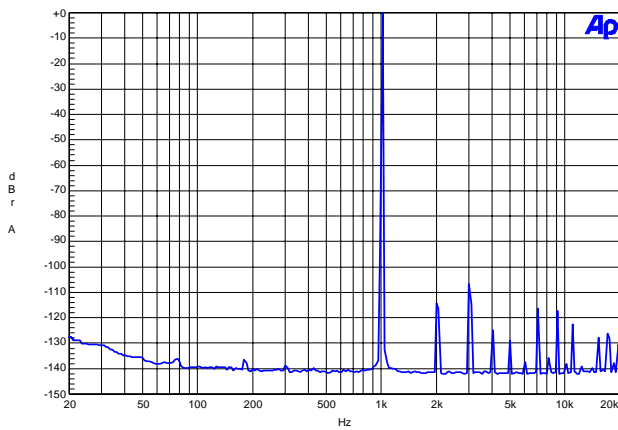
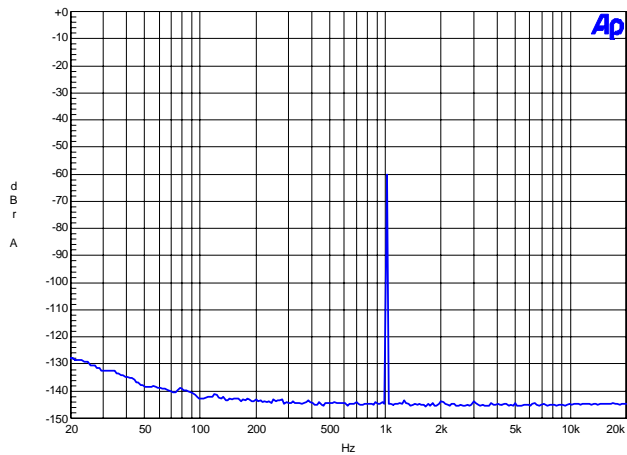
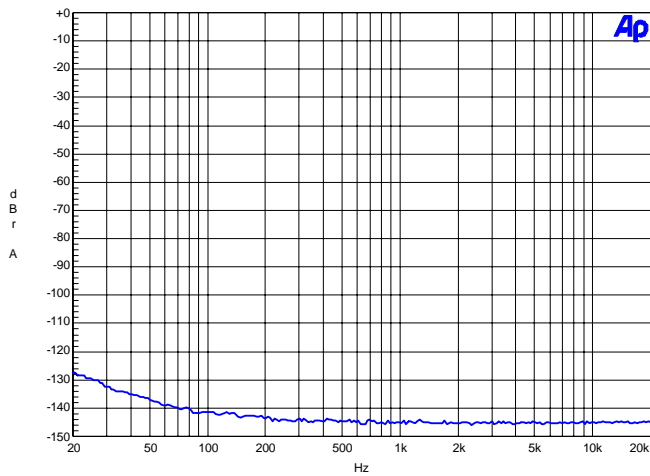
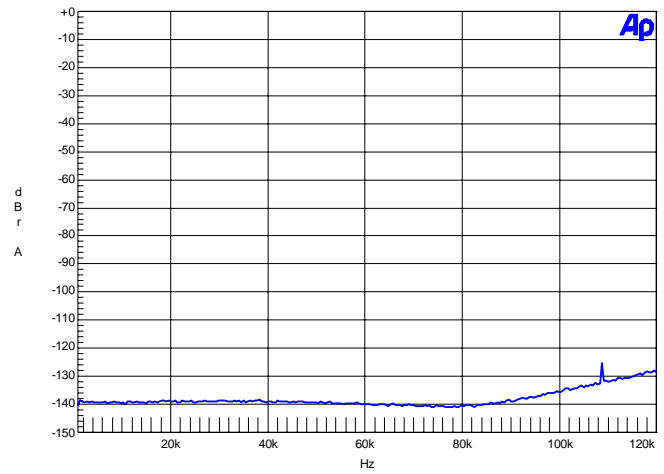
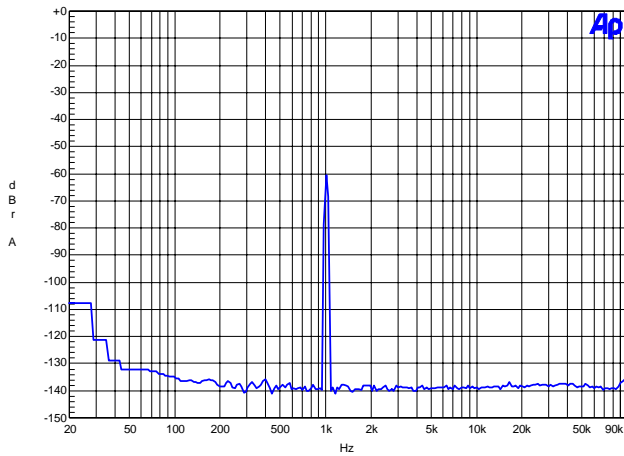
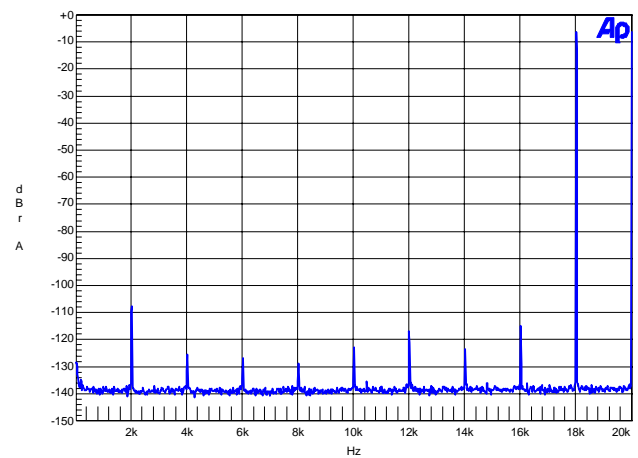
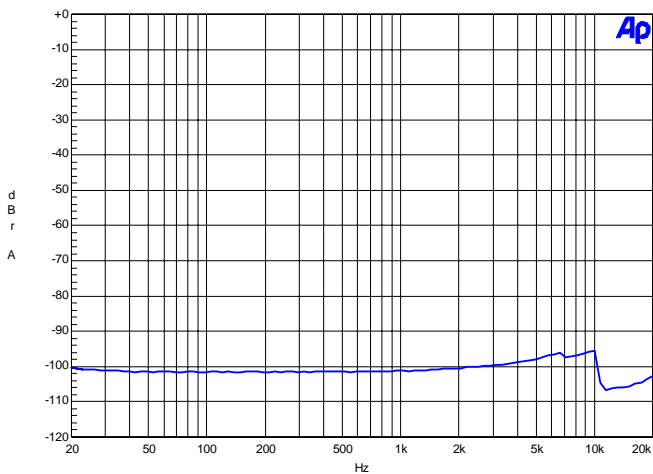
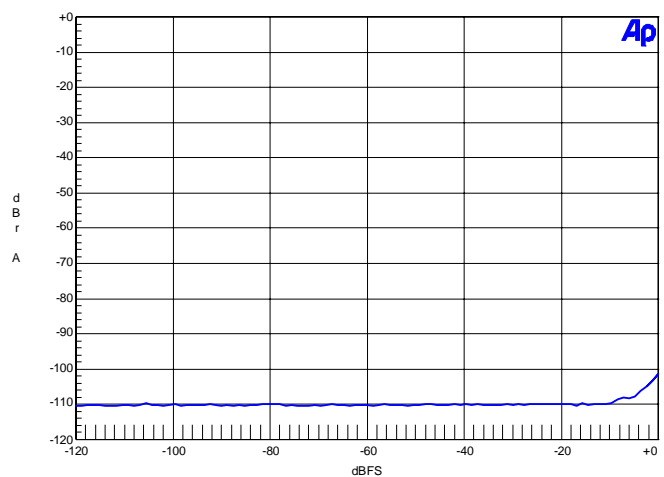

Figure 16. FFT (96 kHz, -60 dB)

Figure 17. FFT (96 kHz, No Input)

Figure 18. FFT (96 kHz Out-of-Band, No Input)

Figure 19. FFT (96 kHz, -60 dB Wideband)

Figure 20. FFT (IMD 96 kHz)

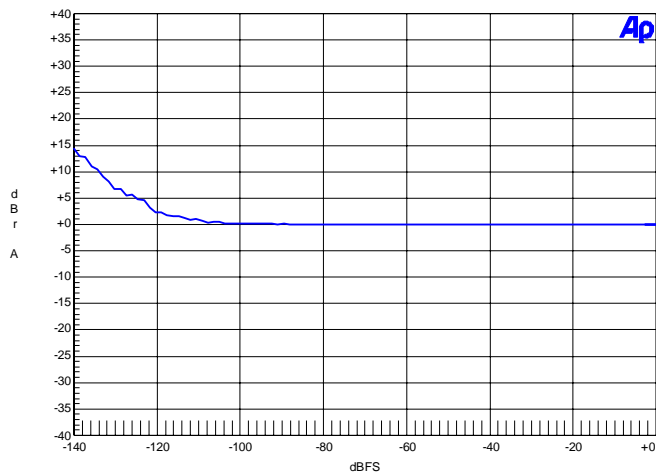
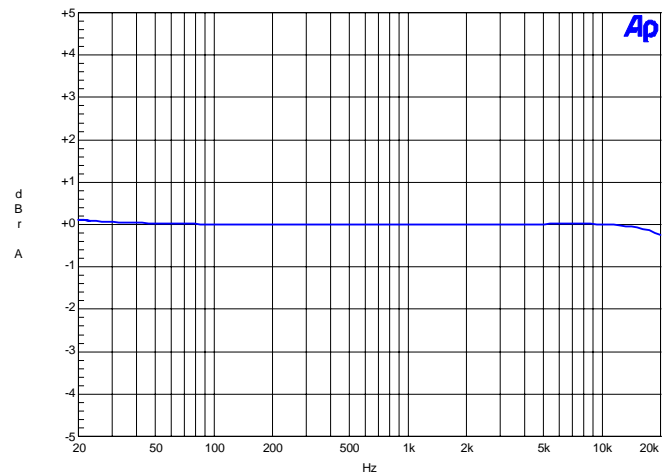
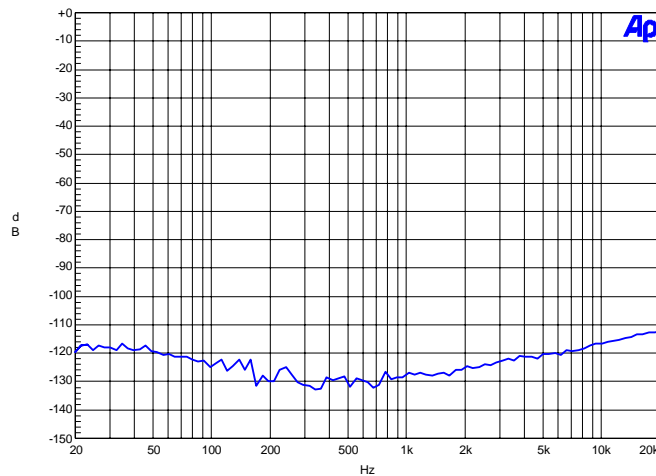
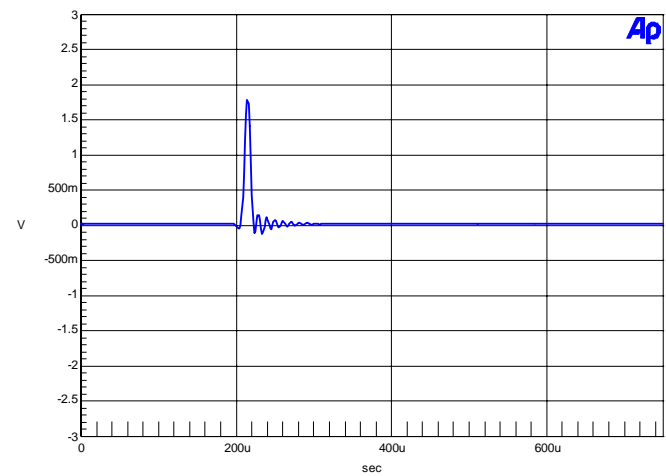
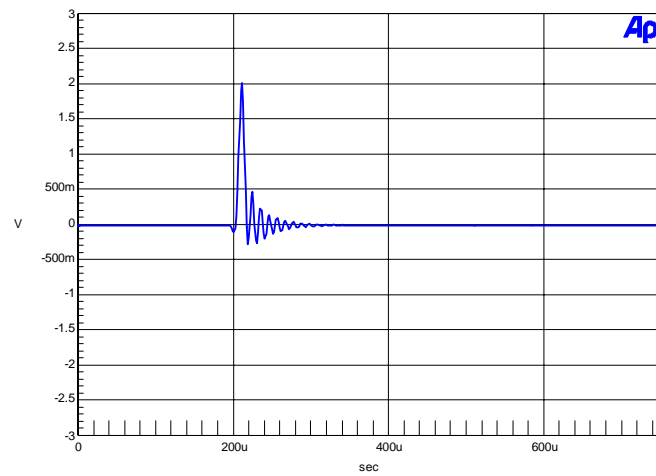
Figure 21. 96 kHz, THD+N vs. Input Freq

Figure 22. 96 kHz, THD+N vs. Level

Figure 23. 96 kHz, Fade-to-Noise Linearity

Figure 24. 96 kHz, Frequency Response

Figure 25. 96 kHz, Crosstalk

Figure 26. 96 kHz, Impulse Response

Figure 27. 96 kHz, Impulse Prefilter

Figure 28. Dynamic Range 96 kHz

Figure 29. FFT (192 kHz, 0 dB)

Figure 30. FFT (192 kHz, -60 dB)

Figure 31. FFT (192 kHz, No Input)

Figure 32. FFT (192 kHz Out-of-Band, No Input)

Figure 33. FFT (192 kHz, -60 dB Wideband)

Figure 34. FFT (IMD 192 kHz)

Figure 35. 192 kHz, THD+N vs. Input Freq

Figure 36. 192 kHz, THD+N vs. Level

Figure 37. 192 kHz, Fade-to-Noise Linearity

Figure 38. 192 kHz, Frequency Response

Figure 39. 192 kHz, Crosstalk

Figure 40. 192 kHz, Impulse Response

Figure 41. 192 kHz, Impulse Prefilter

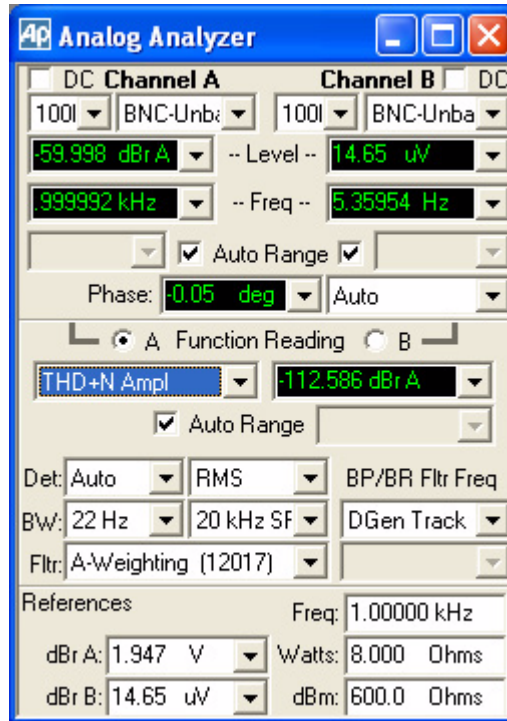
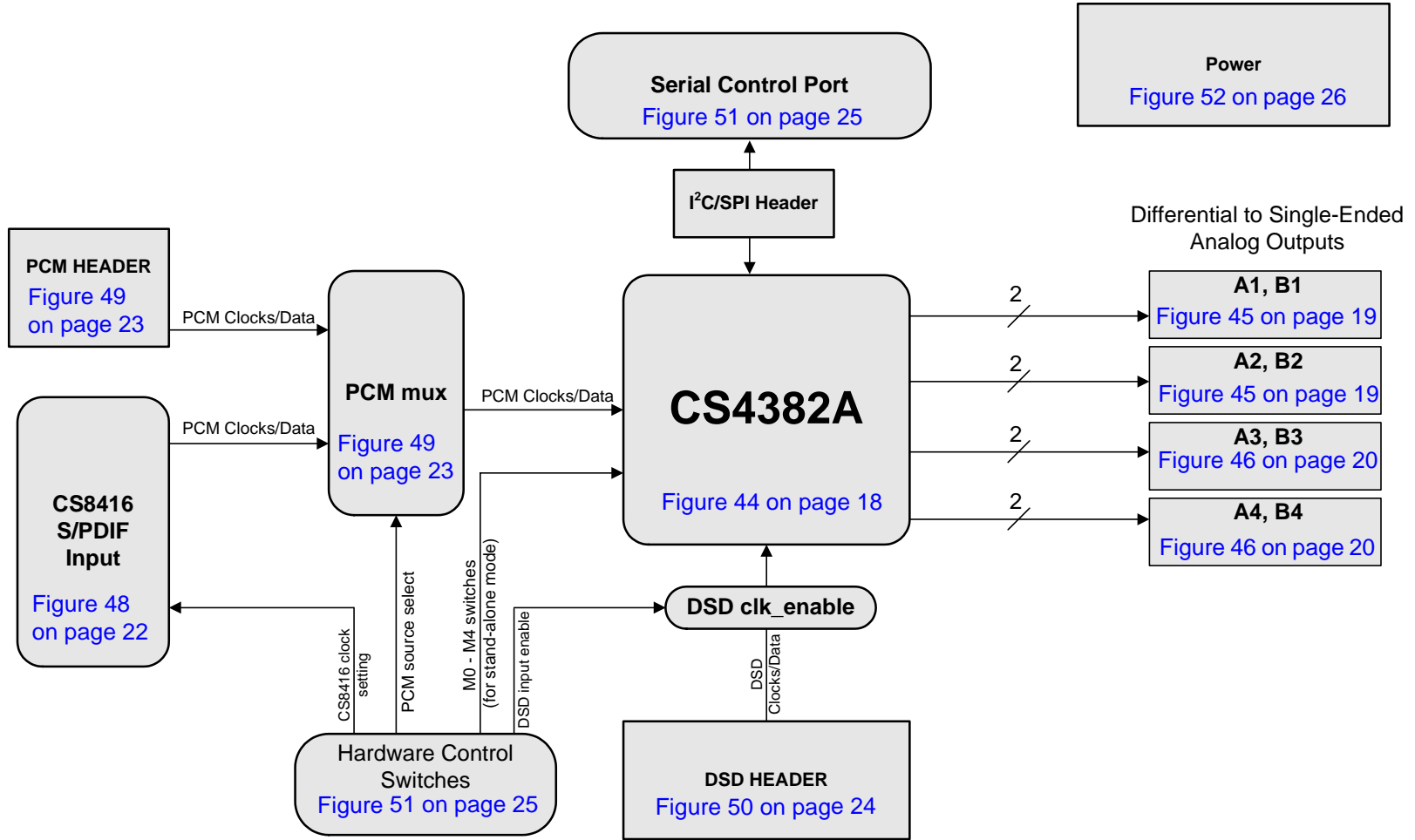
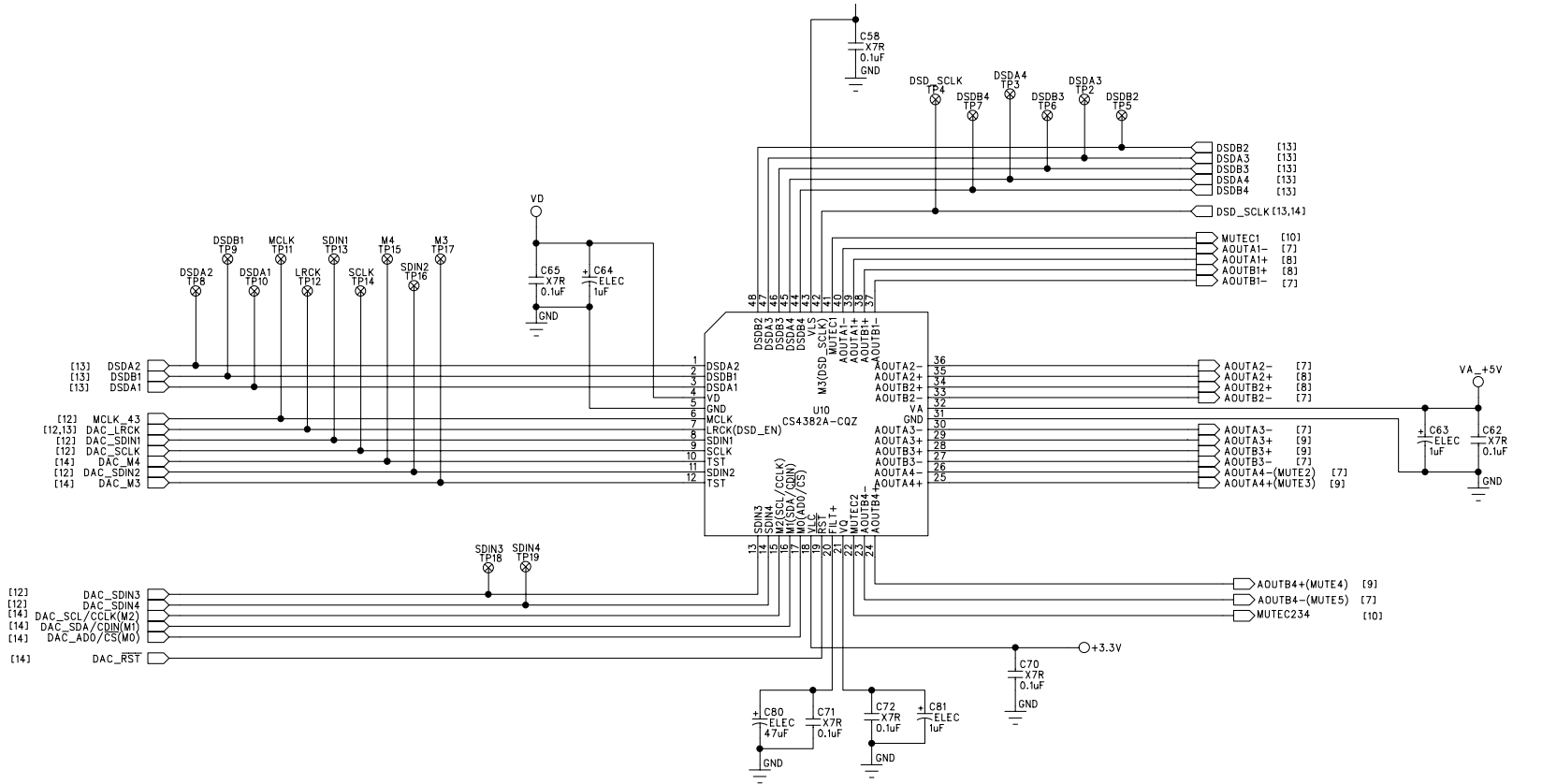

Figure 42. Dynamic Range 192 kHz

9. SCHEMATICS

Figure 43. System Block Diagram and Signal Flow





NOTE: ALL RESISTOR VALUES ARE IN OHMS
UNLESS OTHERWISE SPECIFIED.

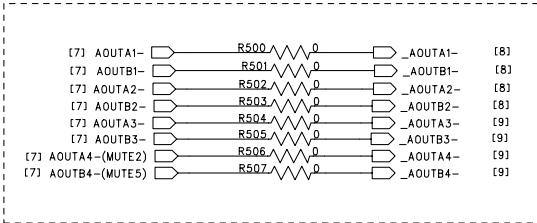
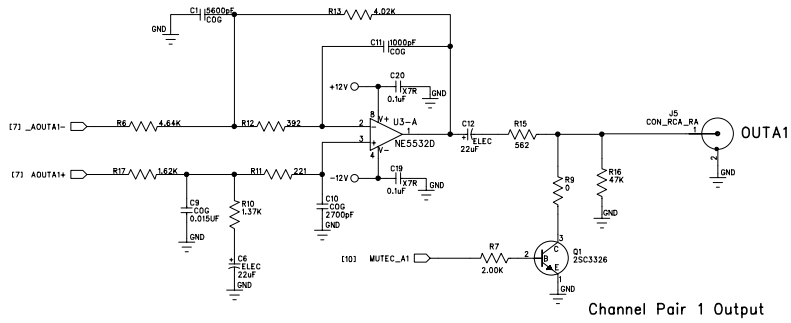

Figure 44. CS4382A



CIRRUS LOGIC®

CDB4382A



Channel Pair 1 Output

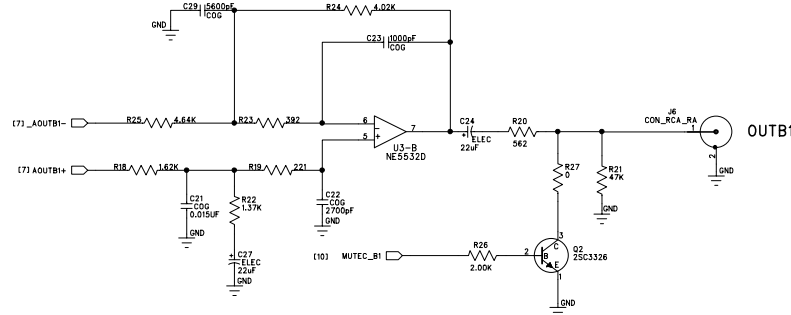

OUTB1

Filter Specs

Gain = -1.4dB
 20kHz = -0.16dB
 48.5 kHz = -3dB

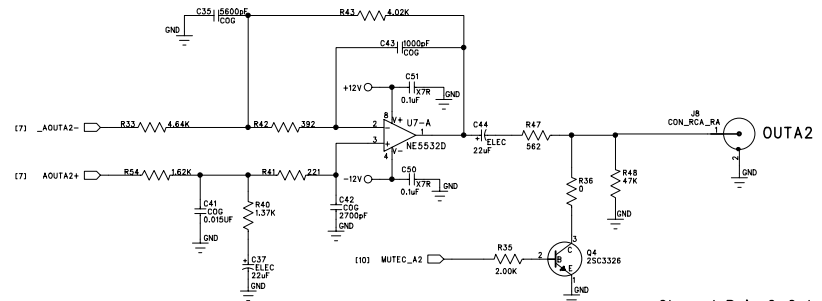

Channel Pair 2 Output

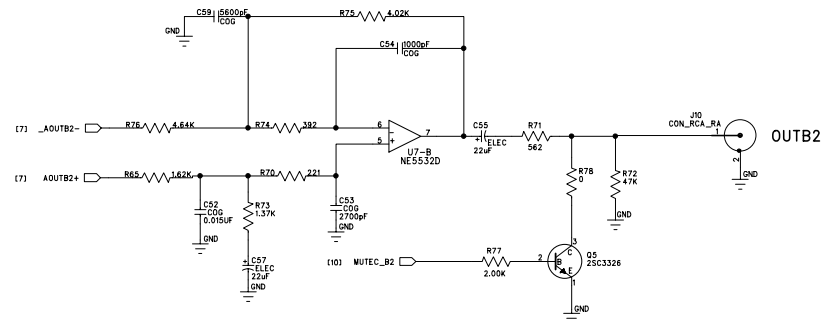

OUTB2

Figure 45. Analog Output Pairs 1 & 2



CIRRUS LOGIC

CDB4382A

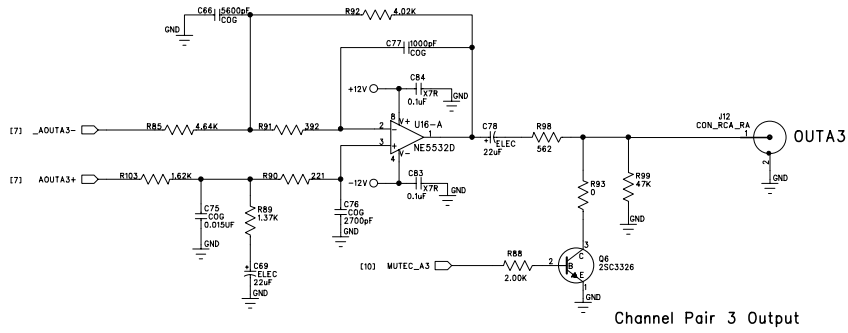

Channel Pair 3 Output

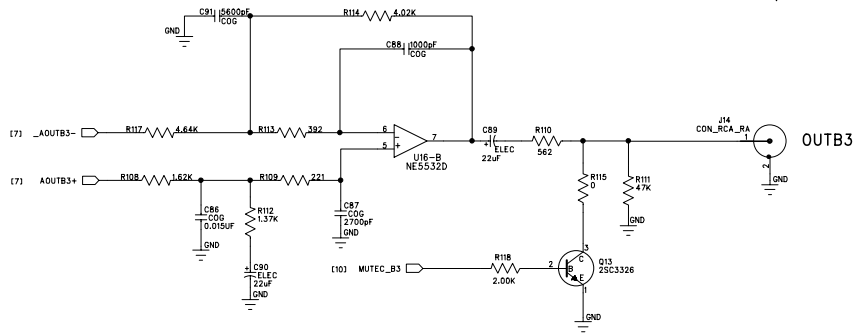

Channel Pair 4 Output

Figure 46. Analog Output Pairs 3 & 4



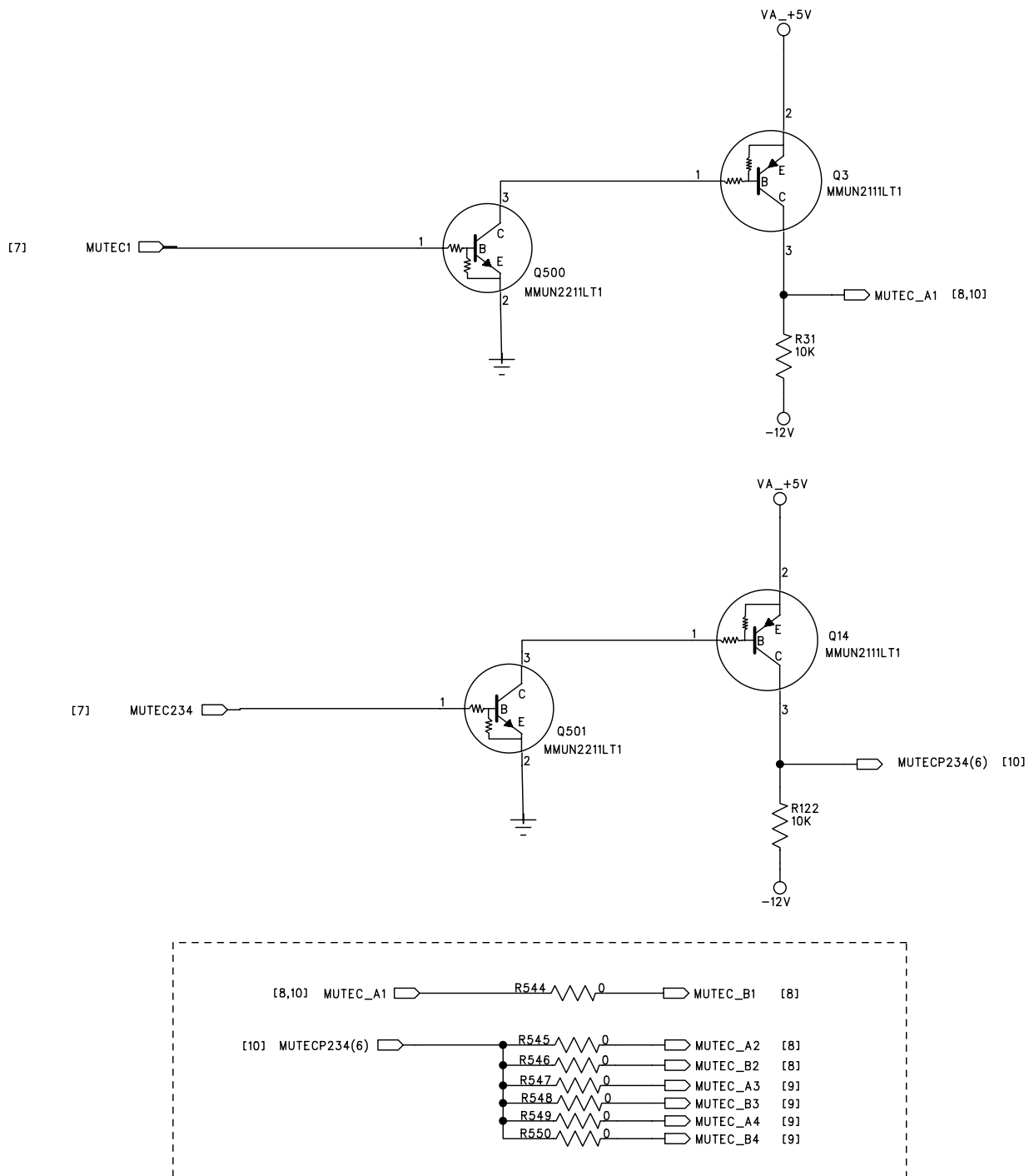
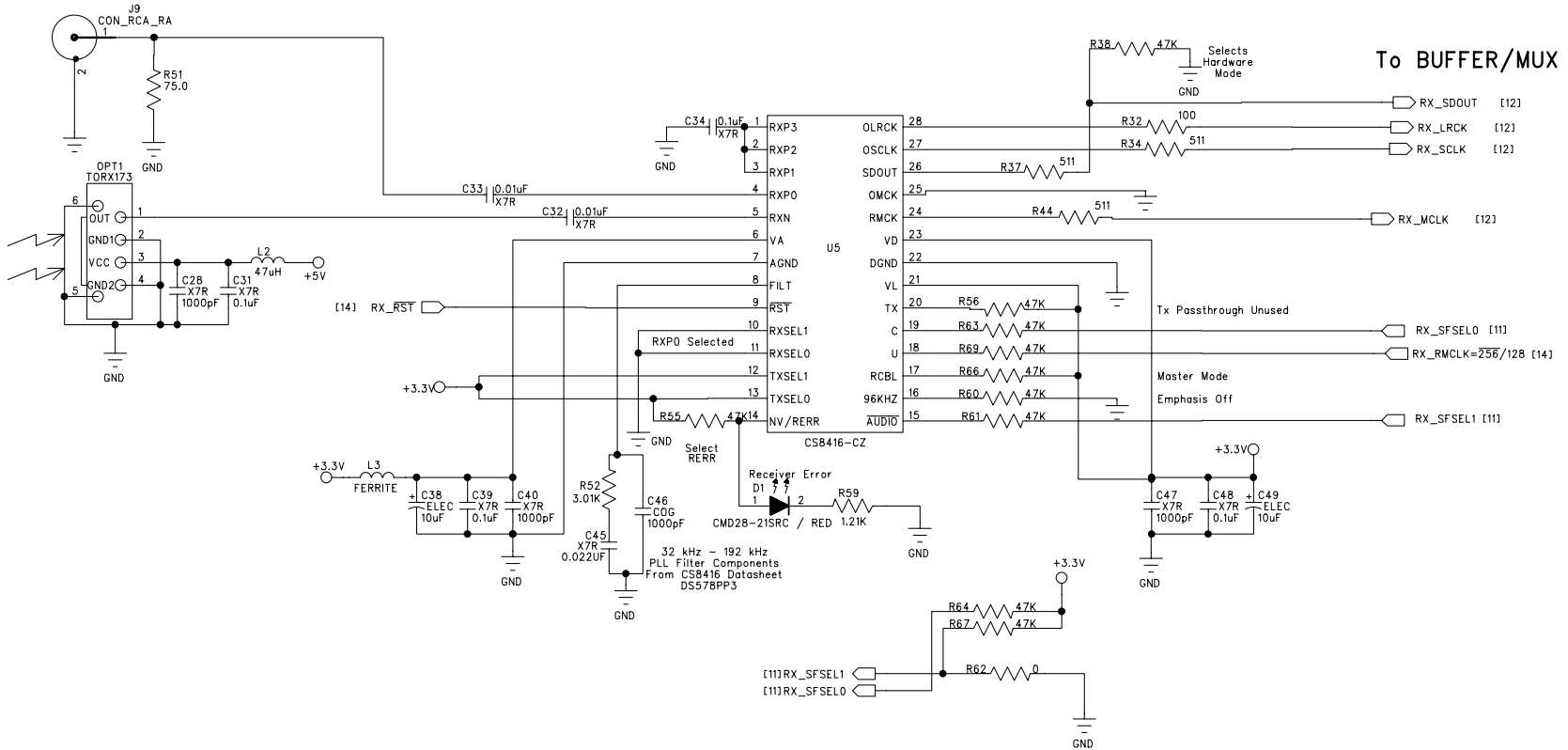

Figure 47. Mute Circuits



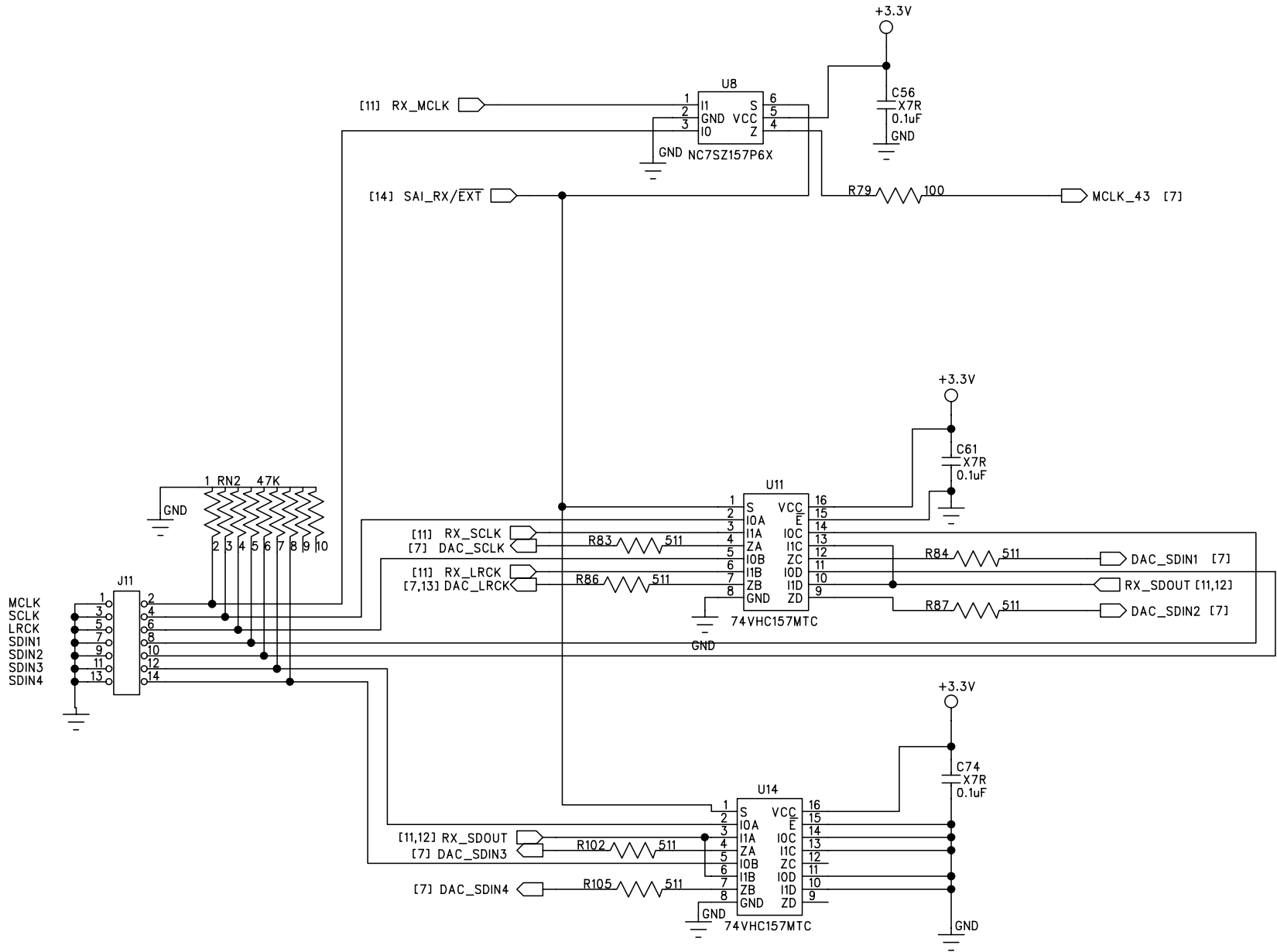

Figure 49. PCM Input Header and Muxing



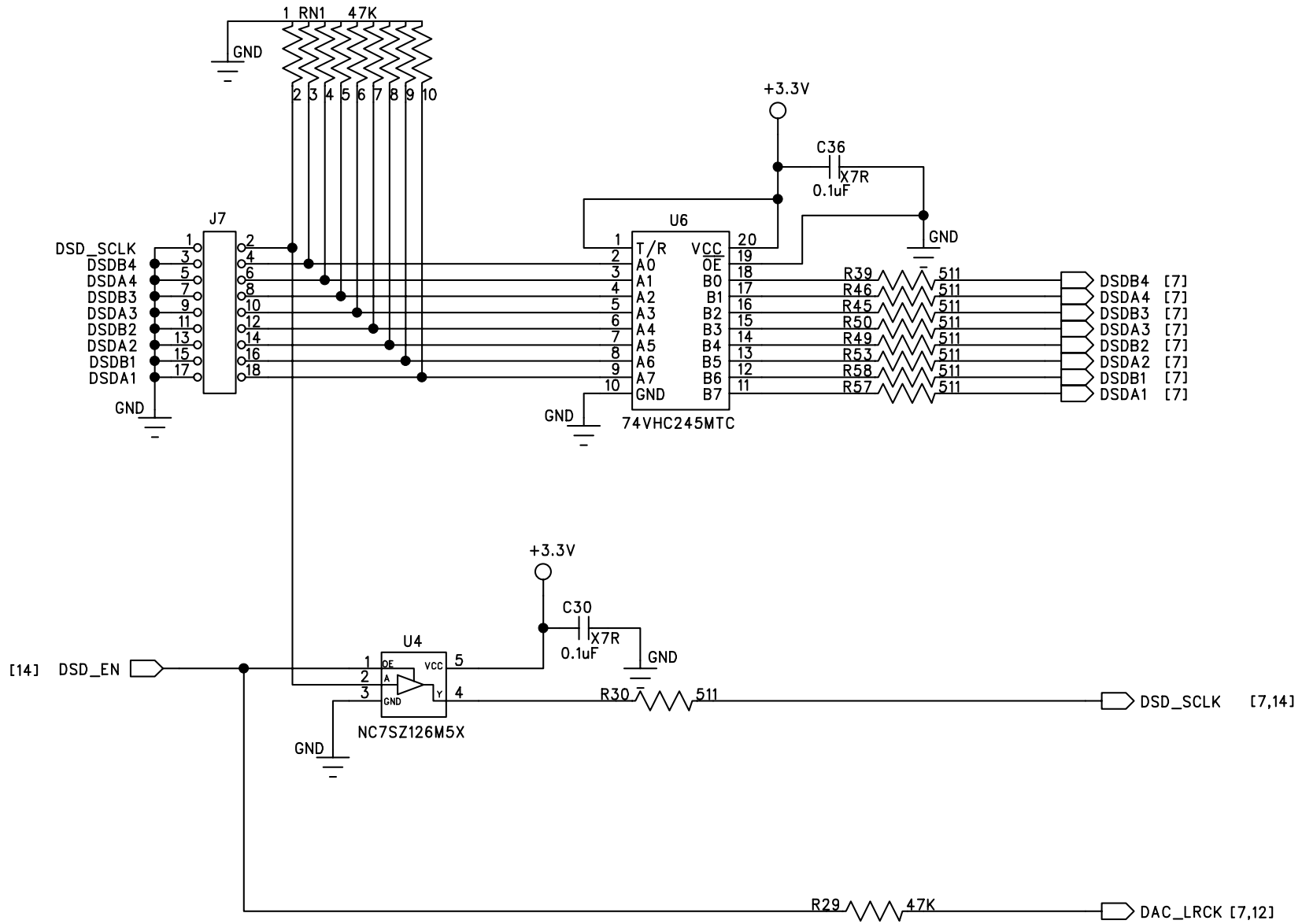

Figure 50. DSD Input Header



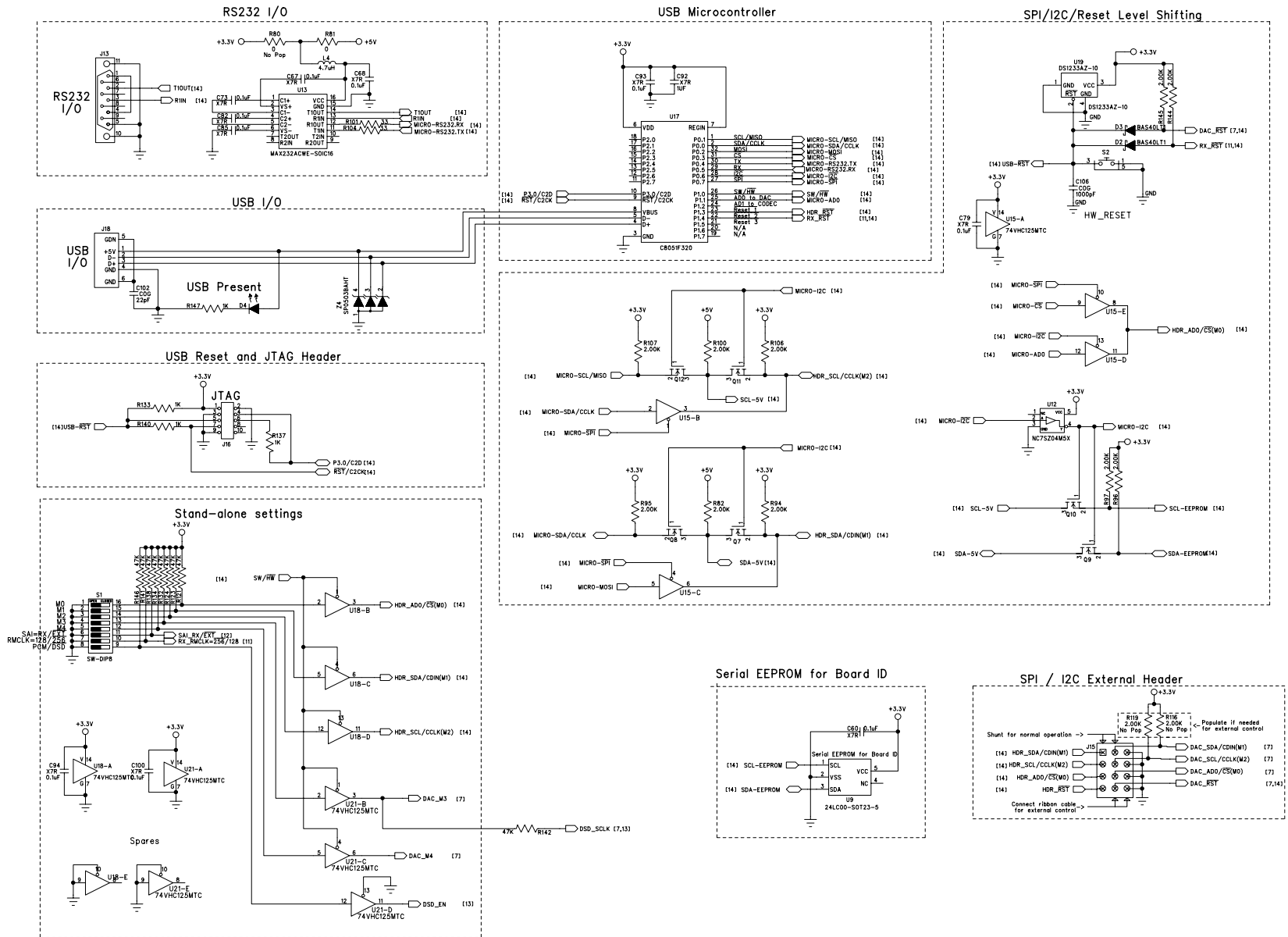

Figure 51. Control Input



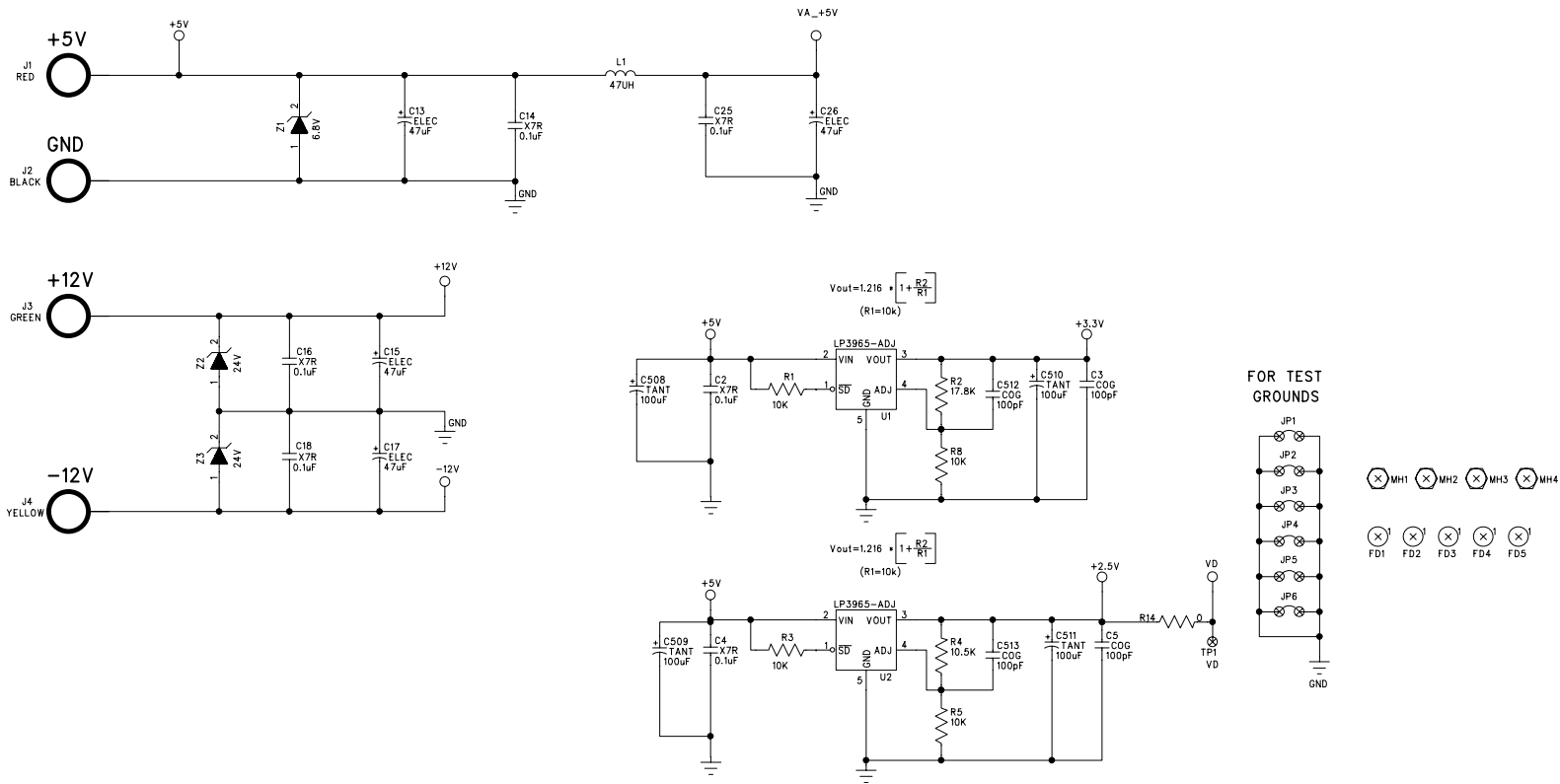
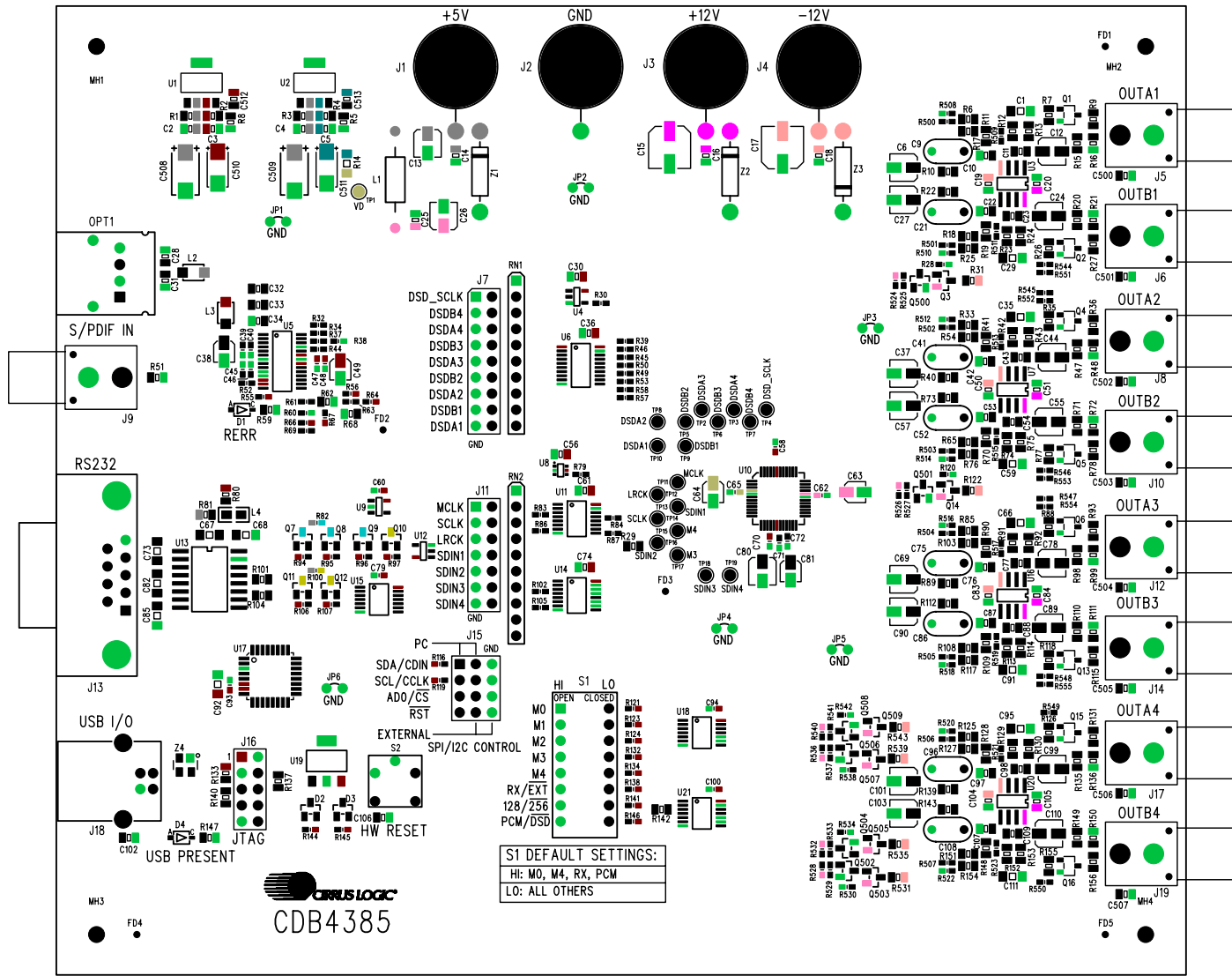

Figure 52. Power Inputs



CIRRUS LOGIC CDB4385 PCB 240-00123-01 Rev C

SILKSCREEN TOP

Figure 53. Silkscreen Top



CIRRUS LOGIC®

CDB4382A

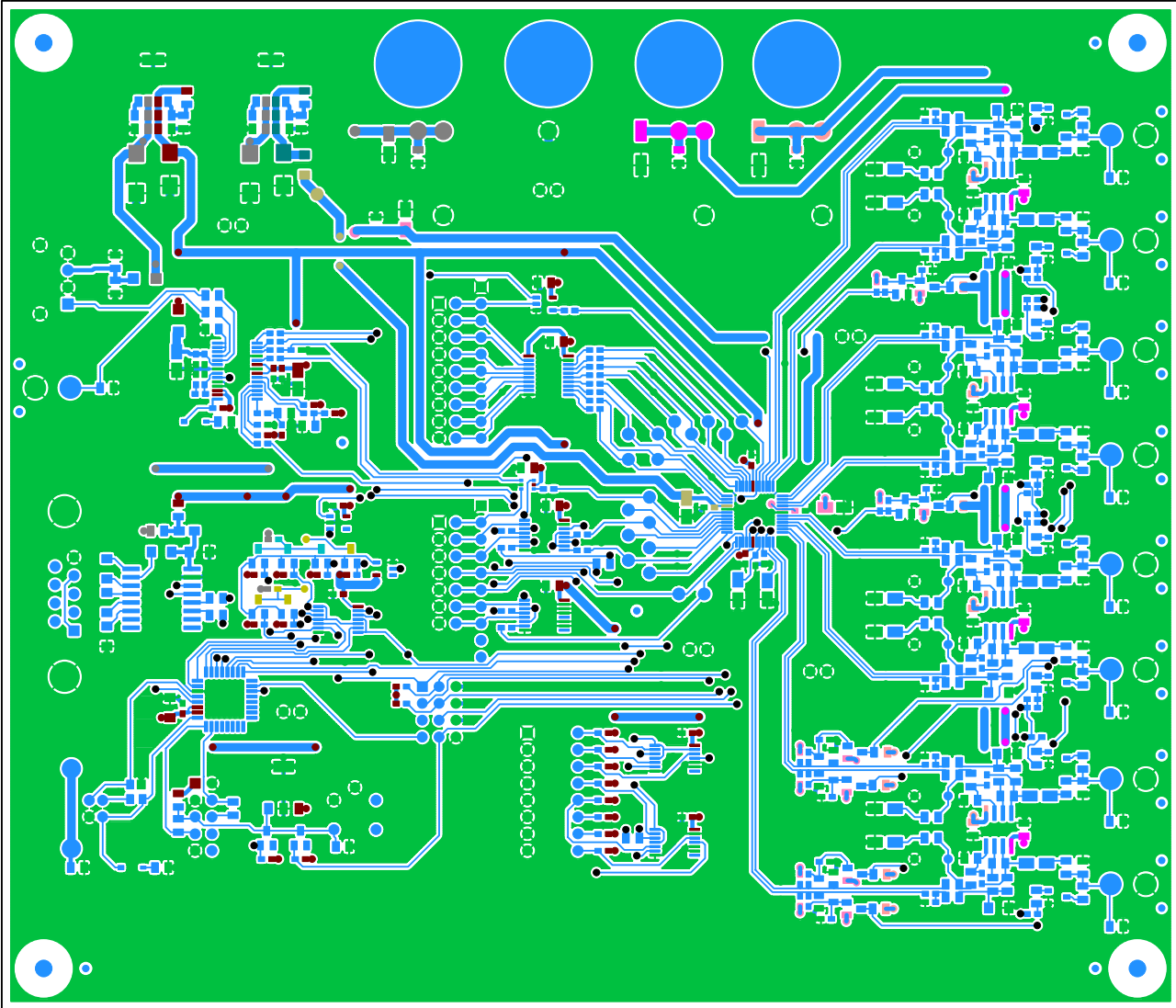

CIRRUS LOGIC CDB4385 PCB 240-00123-01 Rev C

TOP SIDE

Figure 54. Top Side



CIRUS LOGIC®

CDB4382A

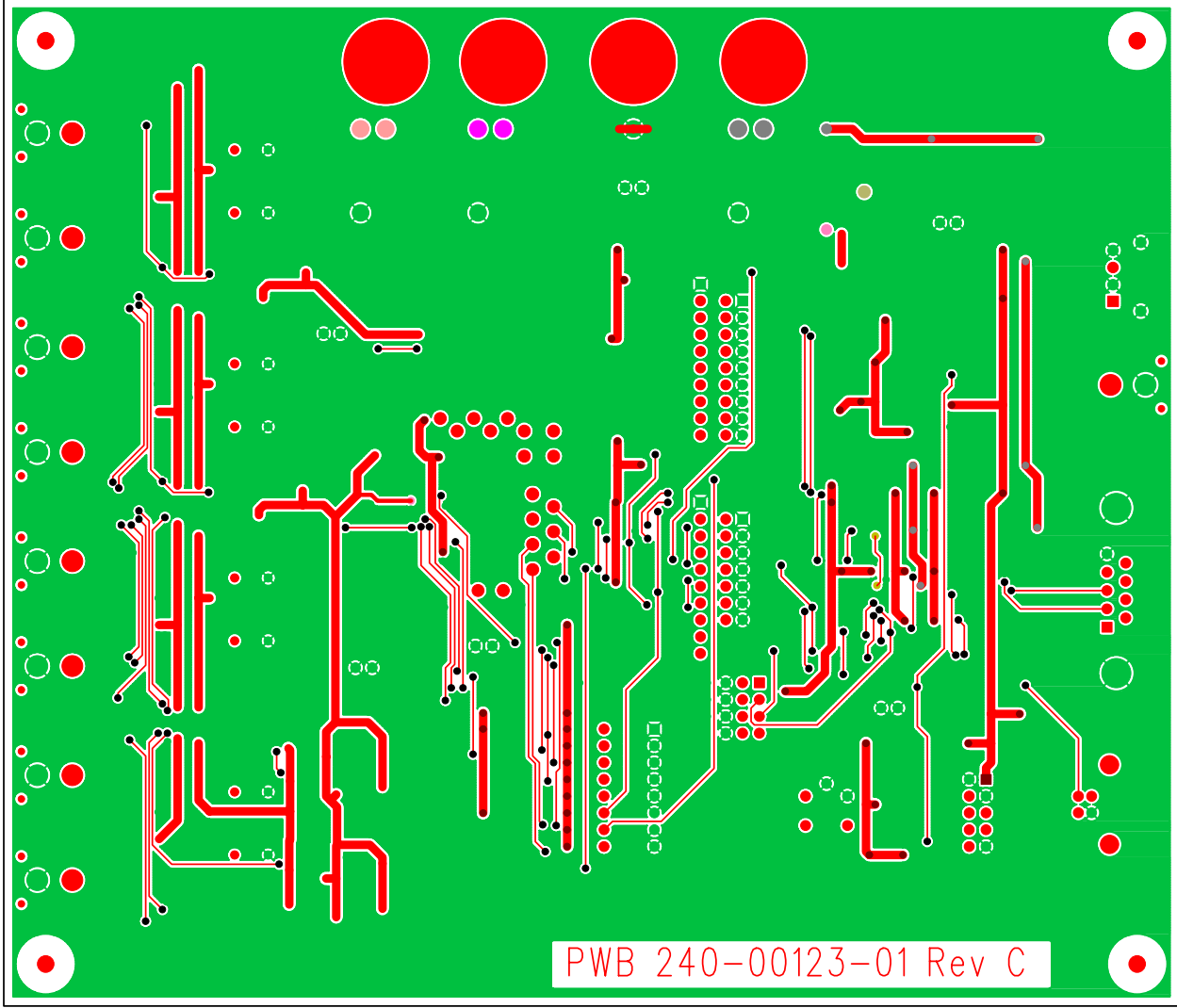

CIRUS LOGIC CDB4382 PCB 240-00123-01 Rev C

BOTTOM SIDE

Figure 55. Bottom Side

10. REVISION HISTORY

Release	Changes
DB1	Initial Release
DB2	Added Performance Plots
DB3	Added USB support to Section 4. Input for Control Data

Contacting Cirrus Logic Support

For all product questions and inquiries, contact a Cirrus Logic Sales Representative.

To find the one nearest to you, go to www.cirrus.com.

IMPORTANT NOTICE

Cirrus Logic, Inc. and its subsidiaries ("Cirrus") believe that the information contained in this document is accurate and reliable. However, the information is subject to change without notice and is provided "AS IS" without warranty of any kind (express or implied). Customers are advised to obtain the latest version of relevant information to verify, before placing orders, that information being relied on is current and complete. All products are sold subject to the terms and conditions of sale supplied at the time of order acknowledgment, including those pertaining to warranty, indemnification, and limitation of liability. No responsibility is assumed by Cirrus for the use of this information, including use of this information as the basis for manufacture or sale of any items, or for infringement of patents or other rights of third parties. This document is the property of Cirrus and by furnishing this information, Cirrus grants no license, express or implied under any patents, mask work rights, copyrights, trademarks, trade secrets or other intellectual property rights. Cirrus owns the copyrights associated with the information contained herein and gives consent for copies to be made of the information only for use within your organization with respect to Cirrus integrated circuits or other products of Cirrus. This consent does not extend to other copying such as copying for general distribution, advertising or promotional purposes, or for creating any work for resale.

CERTAIN APPLICATIONS USING SEMICONDUCTOR PRODUCTS MAY INVOLVE POTENTIAL RISKS OF DEATH, PERSONAL INJURY, OR SEVERE PROPERTY OR ENVIRONMENTAL DAMAGE ("CRITICAL APPLICATIONS"). CIRRUS PRODUCTS ARE NOT DESIGNED, AUTHORIZED OR WARRANTED FOR USE IN PRODUCTS SURGICALLY IMPLANTED INTO THE BODY, AUTOMOTIVE SAFETY OR SECURITY DEVICES, LIFE SUPPORT PRODUCTS OR OTHER CRITICAL APPLICATIONS. INCLUSION OF CIRRUS PRODUCTS IN SUCH APPLICATIONS IS UNDERSTOOD TO BE FULLY AT THE CUSTOMER'S RISK AND CIRRUS DISCLAIMS AND MAKES NO WARRANTY, EXPRESS, STATUTORY OR IMPLIED, INCLUDING THE IMPLIED WARRANTIES OF MERCHANTABILITY AND FITNESS FOR PARTICULAR PURPOSE, WITH REGARD TO ANY CIRRUS PRODUCT THAT IS USED IN SUCH A MANNER. IF THE CUSTOMER OR CUSTOMER'S CUSTOMER USES OR PERMITS THE USE OF CIRRUS PRODUCTS IN CRITICAL APPLICATIONS, CUSTOMER AGREES, BY SUCH USE, TO FULLY INDEMNIFY CIRRUS, ITS OFFICERS, DIRECTORS, EMPLOYEES, DISTRIBUTORS AND OTHER AGENTS FROM ANY AND ALL LIABILITY, INCLUDING ATTORNEYS' FEES AND COSTS, THAT MAY RESULT FROM OR ARISE IN CONNECTION WITH THESE USES.

Cirrus Logic, Cirrus, and the Cirrus Logic logo designs are trademarks of Cirrus Logic, Inc. All other brand and product names in this document may be trademarks or service marks of their respective owners.

DSD is a registered trademark of Sony Kabushiki Kaisha TA Sony Company.

IPC is a registered trademark of Philips Semiconductor.

SPI is a trademark of Motorola, Inc

AMEYA360

Components Supply Platform

Authorized Distribution Brand :



Website :

Welcome to visit www.ameya360.com

Contact Us :

➤ Address :

401 Building No.5, JiuGe Business Center, Lane 2301, Yishan Rd
Minhang District, Shanghai , China

➤ Sales :

Direct +86 (21) 6401-6692

Email amall@ameya360.com

QQ 800077892

Skype [ameyasales1](#) [ameyasales2](#)

➤ Customer Service :

Email service@ameya360.com

➤ Partnership :

Tel +86 (21) 64016692-8333

Email mkt@ameya360.com