

Small Plastic Package, Dual SPDT Analog Switch

Features

- CMOS Technology for Bus and Analog Applications
- Low On-Resistance: 0.45Ω
- Wide V_{DD} Range: 1.65V to 4.2V
- Rail-to-Rail Signal Range
- High Off Isolation: -83dB @ 100kHz
- Crosstalk Rejection Reduces Signal Distortion: -108dB @ 100kHz
- Break-Before-Make Switching
- Extended Industrial Temperature Range: -40 °C to 85 °C
- ESD protection : 4kV(HBM)
- Packaging (Pb-free & Green):
-10-pin UQFN (ZM), 1.4mm x 1.8mm

Applications

- Cell Phones
- PDAs
- MP3 Players
- Portable Instrumentation
- Computer Peripherals
- Speaker Headset Switching
- Power Routing
- Relay Replacement
- Audio and Video Signal Routing
- PCMCIA Cards
- Modems

Pin Configuration (top view)

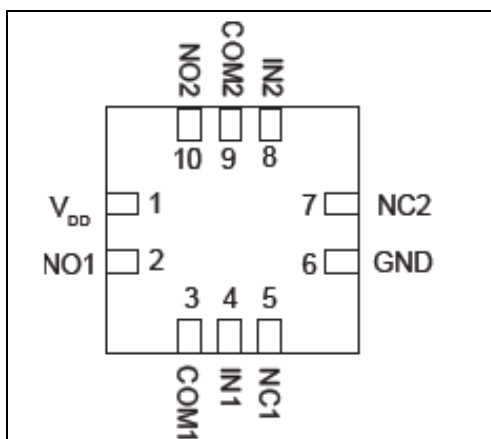

Description

PI3A223 is a dual fast single-pole double throw (SPDT) CMOS switch. It can be used as an analog switch or as a low-delay bus switch. Specified over a wide operating power supply voltage, 1.65V to 4.2V, the PI3A223 has an On-Resistance of 0.45Ω at +4.2V.

Break-before-make switching prevents both switches being enabled simultaneously. This eliminates signal disruption during switching.

Functional Block Diagram

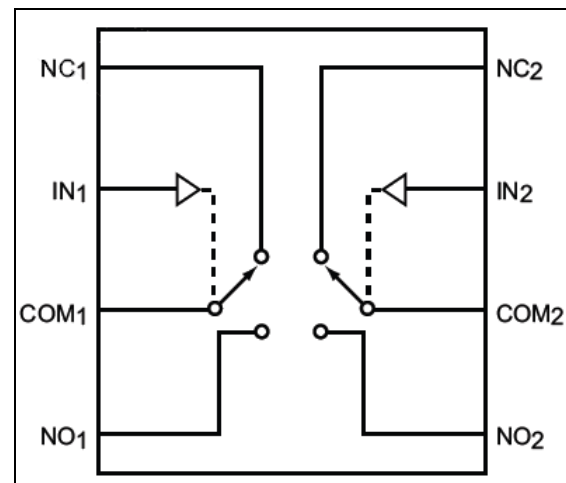

Pin Description

Pin no	Name	Description
1	V _{DD}	Positive Power Supply
2	NO1	Data Port (Normally open)
3	COM1	Common Output / Data Port
4	IN1	Logic Control
5	NC1	Data Port (Normally closed)
6	GND	Ground
7	NC2	Data Port (Normally closed)
8	IN2	Logic Control
9	COM2	Common Output / Data Port
10	NO2	Data Port (Normally open)

Logic Function Table

Logic Input (IN _x)	Function
0	NC _x Connected to COM _x
1	NO _x Connected to COM _x

Note: x = 1 or 2

Maximum Ratings

Storage Temperature.....	-65°C to +150°C
Ambient Temperature with Power Applied.....	-40°C to +85°C
Supply Voltage V_{DD}	-0.5V to +4.6V
Control Input Voltage V_{INx}	0V to +4.6V
DC Input Voltage V_{INPUT}	-0.5V to +4.6V
Continuous Current NO_NC_COM_.....	±300mA
Peak Current NO_NC_COM_	
(pulsed at 1ms 50% duty cycle)	±400mA
Peak Current NO_NC_COM_	
(pulsed at 1ms 10% duty cycle)	±500mA
ESD(HBM)	4kV

Note:

Stresses greater than those listed under MAXIMUM RATINGS may cause permanent damage to the device. This is a stress rating only and functional operation of the device at these or any other conditions above those indicated in the operational sections of this specification is not implied. Exposure to absolute maximum rating conditions for extended periods may affect reliability.

The input and output negative voltage ratings may be exceeded if the input and output diode current ratings are observed.

Control input must be held HIGH or LOW; it must not float.

Recommended Operating Conditions

Symbol	Parameter	Conditions	Min.	Typ.	Max.	Unit
V_{DD}	Operating Voltage	-	1.65	-	4.2	V
V_{IN}	Control Input Voltage	-	0	-	V_{DD}	V
V_{INPUT}	Switch Input Voltage	-	-0.3	-	4.2	V
T_A	Operating Temperature	-	-40	25	85	°C
t_r, t_f	Input Rise and Fall Time	-	0	-	10	ns/V

DC Electrical Characteristics

+3.0V Supply ($V_{DD} = 2.7V$ to $3.6V$, $V_{IH} = +1.6V$, $V_{IL} = +0.4V$, $T_A = -40^\circ C$ to $85^\circ C$, unless otherwise noted. Typical values are at $3.0V$ and $+25^\circ C$.)

Parameter	Symbol	Test Conditions	TEMP	Min.	Typ.	Max.	Units	
ANALOG SWITCH								
Analog Signal Range	V_{NO} , V_{NC} , V_{COM}	-	$-40^\circ C$ to $85^\circ C$	0	-	V_{DD}	V	
On-Resistance	R_{ON}	$V_{DD} = 2.7V$, $I_{COM} = 100mA$, V_{NO} or $V_{NC} = 1V$, <i>Test Circuit 1</i>	$+25^\circ C$	-	0.55	0.9	Ω	
			$-40^\circ C$ to $85^\circ C$	-	0.55	1		
On-Resistance Match Between Channels	ΔR_{ON}	$V_{DD} = 2.7V$, $I_{COM} = 100mA$, V_{NO} or $V_{NC} = 1V$, <i>Test Circuit 1</i>	$+25^\circ C$	-	0.05	0.22	Ω	
			$-40^\circ C$ to $85^\circ C$	-	0.05	0.25		
On-Resistance Flatness	R_{ONF}	$V_{DD} = 2.7V$, $I_{COM} = 100mA$, V_{NO} or $V_{NC} = 1V$, $2.5V$, <i>Test Circuit 1</i>	$+25^\circ C$	-	0.1	0.22	Ω	
			$-40^\circ C$ to $85^\circ C$	-	0.1	0.26		
Source Off Leakage Current	$I_{OFF(NO)}$ or $I_{OFF(NC)}$	$V_{DD} = 3.6V$, V_{NO} or $V_{NC} = 3.3V/0.3V$, $V_{COM} = 0.3V/3.3V$	$-40^\circ C$ to $85^\circ C$	-	-	1	μA	
Channel On Leakage Current	$I_{NC(ON)}$, $I_{NO(ON)}$, $I_{COM(ON)}$	$V_{DD} = 3.6V$, V_{NO} or $V_{NC} = 3V/0.3V$, $V_{COM} = 3V/0.3V$, or floating	$-40^\circ C$ to $85^\circ C$	-	-	1		
DIGITAL INPUTS								
Input Logic High	V_{IH}	-	$-40^\circ C$ to $85^\circ C$	1.2	-	-	V	
Input Logic Low	V_{IL}	-	$-40^\circ C$ to $85^\circ C$	-	-	0.5		
IN Input Leakage Current	I_{IN}	$V_{DD} = 2.7V$, $V_{IN} = 0$ or $2.7V$	$-40^\circ C$ to $85^\circ C$	-	-	1	μA	
DYNAMIC CHARACTERISTICS								
Turn-On Time	t_{ON}	$V_{IH} = 1.5V$, $V_{IL} = 0V$, <i>See Test Circuit Figure 2.</i>	$+25^\circ C$	-	16	-	ns	
Turn-Off Time	t_{OFF}	$V_{IH} = 1.5V$, $V_{IL} = 0V$, <i>See Test Circuit Figure 2.</i>	$+25^\circ C$	-	60	-	ns	
Break-Before-Make Delay	t_D	$V_{IH} = 1.5V$, $V_{IL} = 0V$, <i>See Test Circuit Figure 3.</i>	$+25^\circ C$	-	10	-	ns	
COM-NC/NO and NC-NO Isolations	O_{ISO}	$V_{BIAS} = 1.5V$, $V_{IN} = 0dBm$, $V_{IH} = 1.5V$, $V_{IL} = 0V$. <i>See Test Circuit Figure 4 & Figure 5.</i>	100kHz	$+25^\circ C$	-	-81	-	dB
			1MHz	$+25^\circ C$	-	-61	-	
			10MHz	$+25^\circ C$	-	-39	-	
Channel-to-Channel Crosstalk	X_{TALKD}	$V_{BIAS} = 1.5V$, $V_{DD} = 0dBm$, $V_{IH} = 1.5V$, $V_{IL} = 0V$ <i>See Test Circuit Figure 6.</i>	100kHz	$+25^\circ C$	-	-108	-	dB
			1MHz	$+25^\circ C$	-	-110	-	
			10MHz	$+25^\circ C$	-	-90	-	
3dB Bandwidth	f_{3dB}	$V_{BIAS} = 1.5V$, $V_{IN} = 0dBm$, $V_{IH} = 1.5V$, $V_{IL} = 0V$. <i>See Test Circuit Figure 7.</i>	$+25^\circ C$	-	79	-	MHz	
Charge Injection Select Input to Common I/O	Q	$V_{IN} = GND$, $R_S = 0$, $C_L = 1nF$, $V_{IH} = 1.5V$, $V_{IL} = 0V$ <i>See Test Circuit Figure 8.</i>	$+25^\circ C$	-	35	-	pC	

+4.2V Supply ($V_{DD} = 4.2V$, $T_A = -40\text{ }^\circ\text{C}$ to $85\text{ }^\circ\text{C}$, unless otherwise noted. Typical values are at $4.2V$ and $+25\text{ }^\circ\text{C}$.)

Parameter	Symbol	Test Conditions	TEMP	Min.	Typ.	Max.	Units	
ANALOG SWITCH								
Analog Signal Range	V_{NO}, V_{NC}, V_{COM}	-	$-40\text{ }^\circ\text{C}$ to $85\text{ }^\circ\text{C}$	0	-	V_{DD}	V	
On-Resistance	R_{ON}	$V_{DD} = 4.2V, I_{COM} = 100mA, V_{NO}$ or $V_{NC} = 1V, \text{Test Circuit 1}$	$+25\text{ }^\circ\text{C}$	-	0.45	0.75	Ω	
			$-40\text{ }^\circ\text{C}$ to $85\text{ }^\circ\text{C}$	-	0.45	0.85		
On-Resistance Match Between Channels	ΔR_{ON}	$V_{DD} = 4.2V, I_{COM} = 100mA, V_{NO}$ or $V_{NC} = 1V, \text{Test Circuit 1}$	$+25\text{ }^\circ\text{C}$	-	0.05	0.18	Ω	
			$-40\text{ }^\circ\text{C}$ to $85\text{ }^\circ\text{C}$	-	0.05	0.23		
On-Resistance Flatness	R_{ONF}	$V_{DD} = 4.2V, I_{COM} = 100mA, V_{NO}$ or $V_{NC} = 1V, 2.5V, \text{Test Circuit 1}$	$+25\text{ }^\circ\text{C}$	-	0.1	0.22	Ω	
			$-40\text{ }^\circ\text{C}$ to $85\text{ }^\circ\text{C}$	-	0.1	0.26		
Source Off Leakage Current	$I_{OFF(NO)}$ or $I_{OFF(NC)}$	$V_{DD} = 4.2V, V_{NO}$ or $V_{NC} = 3.3V/0.3V, V_{COM} = 0.3V/3V$	$-40\text{ }^\circ\text{C}$ to $85\text{ }^\circ\text{C}$	-	-	1	μA	
Channel On Leakage Current	$I_{NC(ON)}, I_{NO(ON)}, I_{COM(ON)}$	$V_{DD} = 4.2V, V_{NO}$ or $V_{NC} = 3V/0.3V, V_{COM} = 3V/0.3V, \text{or floating}$	$-40\text{ }^\circ\text{C}$ to $85\text{ }^\circ\text{C}$	-	-	1		
DIGITAL INPUTS								
Input Logic High	V_{IH}	-	$-40\text{ }^\circ\text{C}$ to $85\text{ }^\circ\text{C}$	1.2	-	-	V	
Input Logic Low	V_{IL}	-	$-40\text{ }^\circ\text{C}$ to $85\text{ }^\circ\text{C}$	-	-	0.5		
IN Input Leakage Current	I_{IN}	$V_{DD} = 4.2V, V_{IN} = 0$ or $4.2V$	$-40\text{ }^\circ\text{C}$ to $85\text{ }^\circ\text{C}$	-	-	1	μA	
DYNAMIC CHARACTERISTICS								
Turn-On Time	t_{ON}	$V_{IH} = 3V, V_{IL} = 0V, \text{See Test Circuit Figure 2.}$	$+25\text{ }^\circ\text{C}$	-	13	-	ns	
Turn-Off Time	t_{OFF}	$V_{IH} = 3V, V_{IL} = 0V, \text{See Test Circuit Figure 2.}$	$+25\text{ }^\circ\text{C}$	-	38	-	ns	
Break-Before-Make Delay	t_D	$V_{IH} = 3V, V_{IL} = 0V, \text{See Test Circuit Figure 3.}$	$+25\text{ }^\circ\text{C}$	-	8	-	ns	
COM-NC/NO and NC-NO Isolations	O_{ISO}	$V_{BIAS} = 2.1V, V_{IN} = 0dBm, V_{IH} = 3V, V_{IL} = 0V. \text{See Test Circuit Figure 4 \& Figure 5.}$	100kHz	$+25\text{ }^\circ\text{C}$	-	-83	-	dB
			1MHz	$+25\text{ }^\circ\text{C}$	-	-61	-	
			10MHz	$+25\text{ }^\circ\text{C}$	-	-39	-	
Channel-to-channel Crosstalk	X_{TALK}	$V_{BIAS} = 2.1V, V_{IN} = 0dBm, V_{IH} = 3V, V_{IL} = 0V \text{See Test Circuit Figure 6.}$	100kHz	$+25\text{ }^\circ\text{C}$	-	-108	-	dB
			1MHz	$+25\text{ }^\circ\text{C}$	-	-110	-	
			10MHz	$+25\text{ }^\circ\text{C}$	-	-90	-	
3dB Bandwidth	f_{3dB}	$V_{BIAS} = 2.1V, V_{IN} = 0dBm, V_{IH} = 3V, V_{IL} = 0V. \text{See Test Circuit Figure 7.}$	$+25\text{ }^\circ\text{C}$	-	84	-	MHz	
Charge Injection Select Input to Common I/O	Q	$V_{IN} = GND, R_S = 0, C_L = 1nF, V_{IH} = 3V, V_{IL} = 0V \text{See Test Circuit Figure 8.}$	$+25\text{ }^\circ\text{C}$	-	50	-	pC	
POWER REQUIREMENTS								
Power Supply Range	V_{DD}	-	$-40\text{ }^\circ\text{C}$ to $85\text{ }^\circ\text{C}$	1.65	-	4.2	V	
Power Supply Current	I_{CC}	$V_{DD} = 4.2V, V_{IN} = 0V$ or V_{DD}	$-40\text{ }^\circ\text{C}$ to $85\text{ }^\circ\text{C}$	-	-	1	μA	

Capacitance

Parameter	Symbol	Test Conditions	Min.	Typ.	Max.	Units
NC Off Capacitance	$C_{NC(OFF)}$	$f = 1MHz, \text{See Test Circuit Figure 9.}$	-	20	-	pF
NO Off Capacitance	$C_{NO(OFF)}$	$f = 1MHz, \text{See Test Circuit Figure 9.}$	-	20	-	
NC On Capacitance	$C_{NC(ON)}$	$f = 1MHz, \text{See Test Circuit Figure 10.}$	-	55	-	
NO On Capacitance	$C_{NO(ON)}$	$f = 1MHz, \text{See Test Circuit Figure 10.}$	-	55	-	

Test Circuits and Timing Diagrams

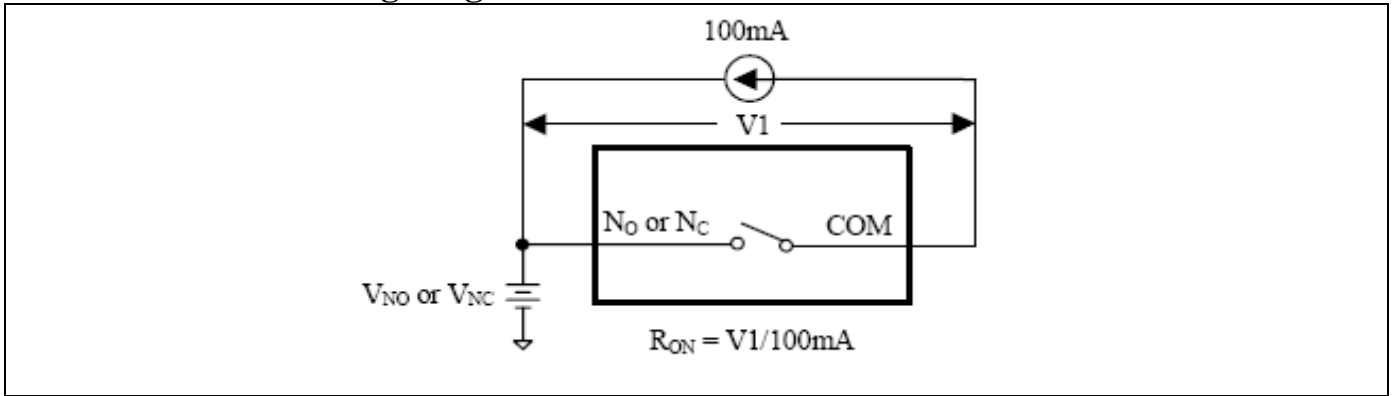

Figure 1. On Resistance

Notes:

1. Unused input (NC or NO) must be grounded.

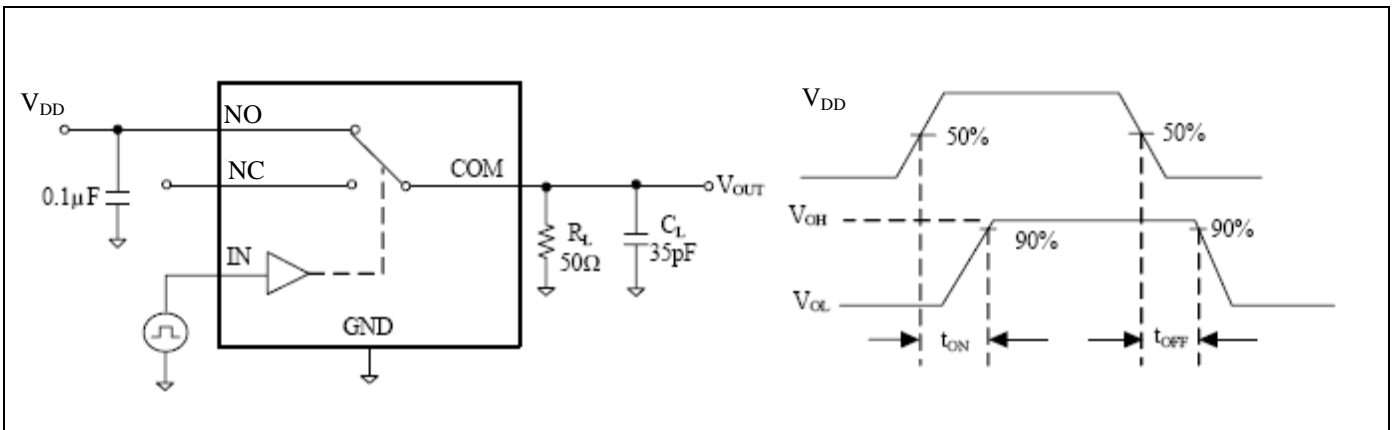

Figure 2. Switching Times

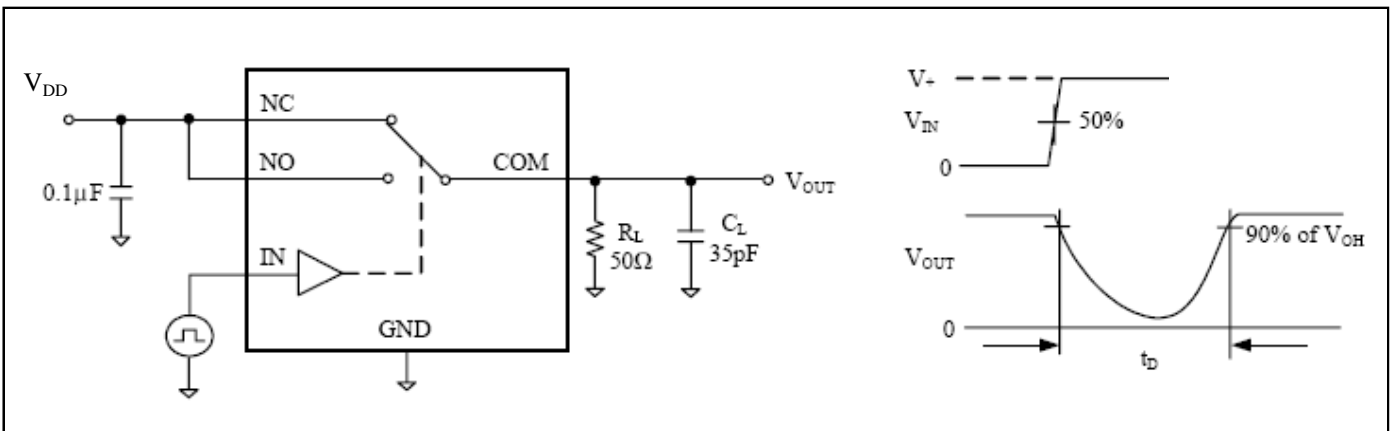

Figure 3. Break Before Make Interval Timing

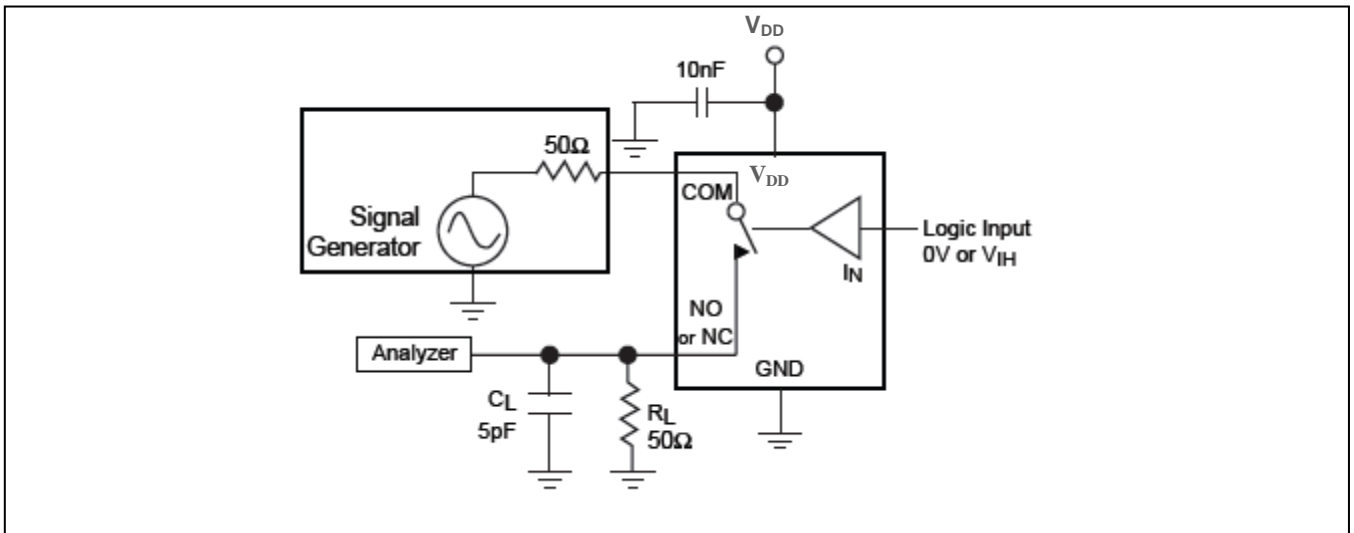

Figure 4. COM-NC/NO Isolation

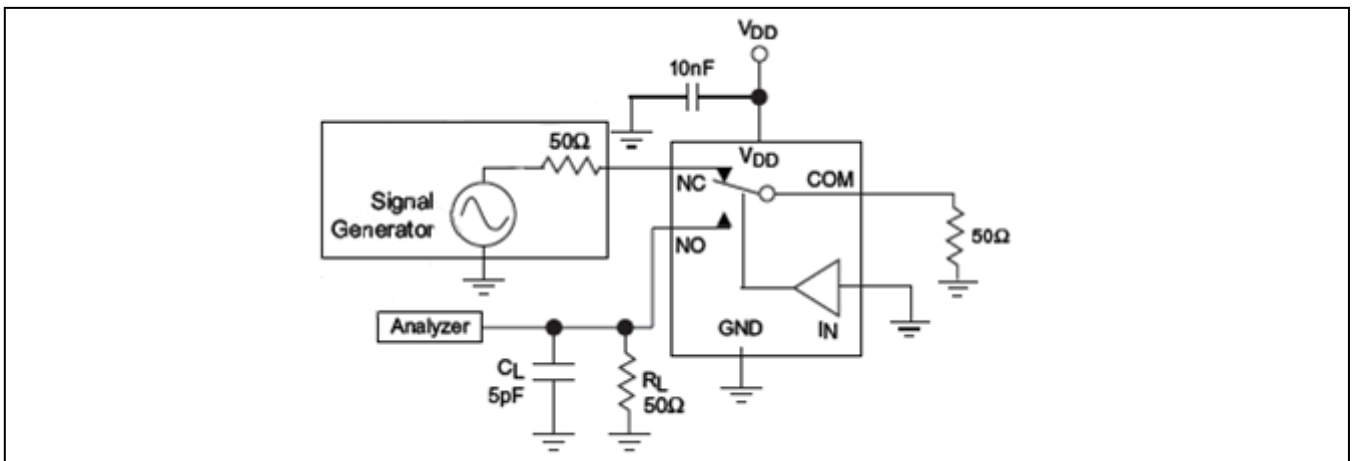

Figure 5. NC-NO Isolation

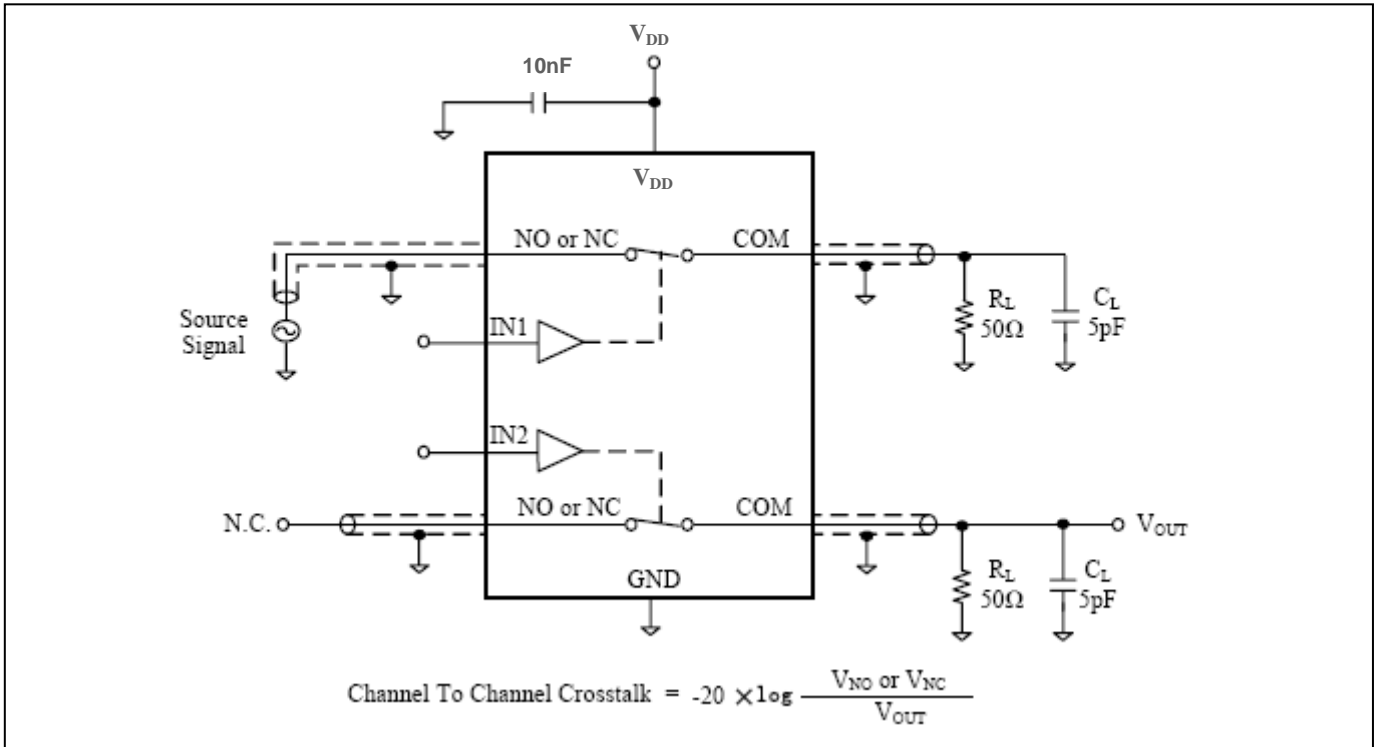

Figure 6. Channel-to-Channel Crosstalk

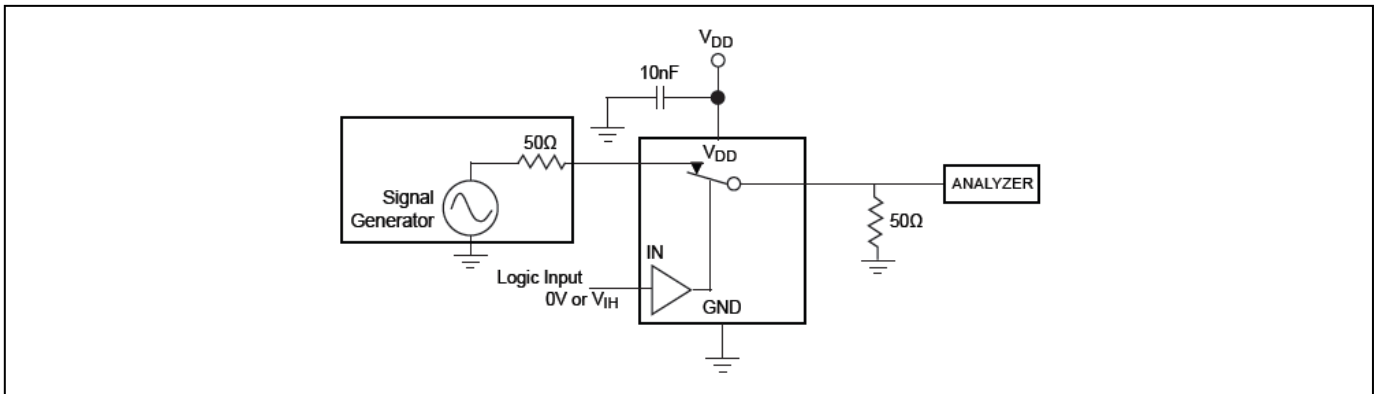

Figure 7. Bandwidth

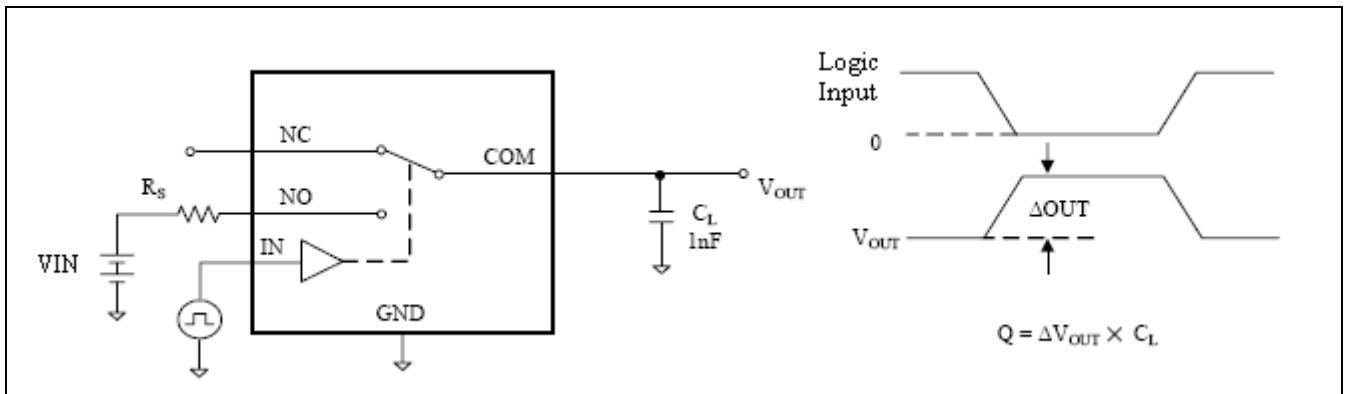

Figure 8. Charge Injection

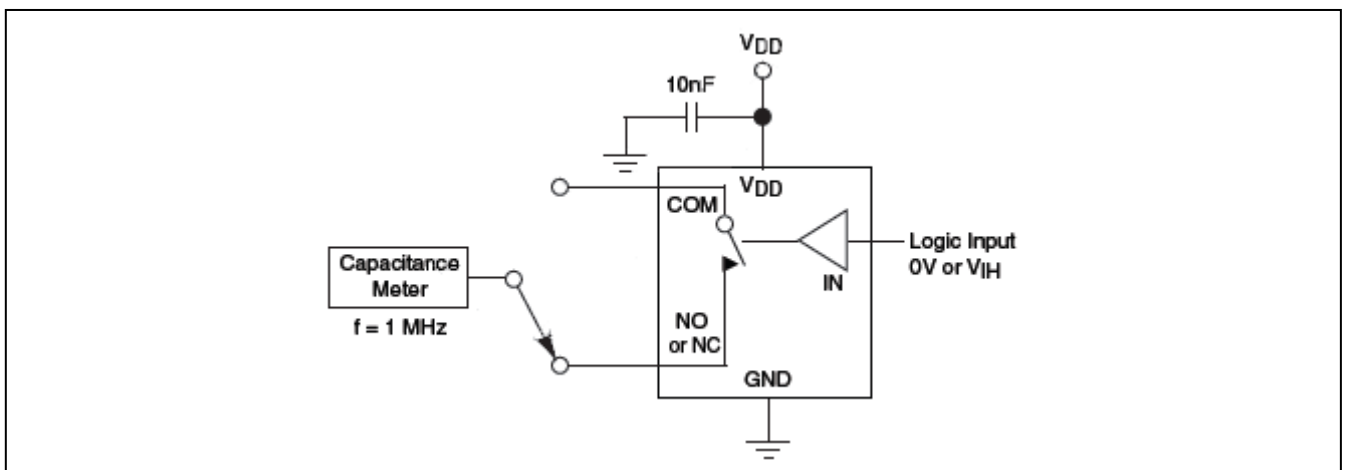

Figure 9. Channel Off Capacitance

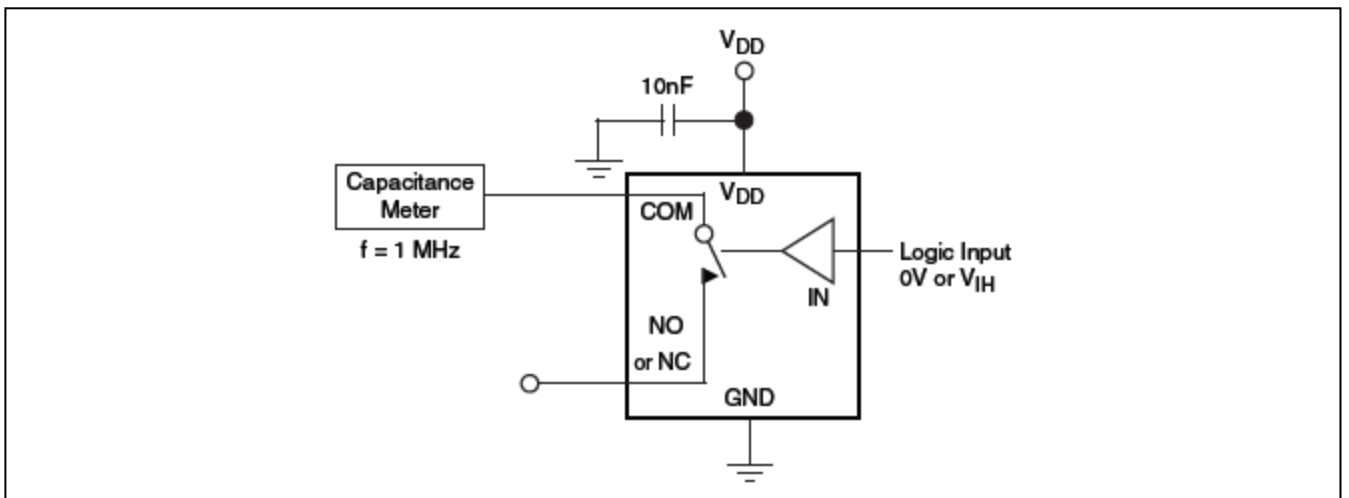
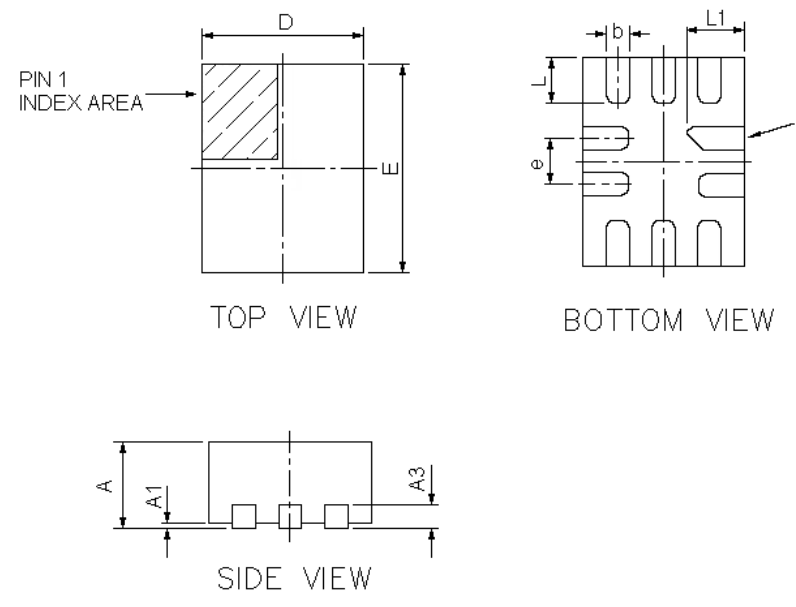

Figure 10. Channel On Capacitance

Mechanical Information
10-pin UQFN (ZM10)



TOP VIEW BOTTOM VIEW

SIDE VIEW

DOCUMENT CONTROL NO.
PD-0044

REVISION: B
DATE: 6/6/2012

PKG. DIMENSIONS(MM)		
SYMBOL	MIN	MAX
A	0.50	0.60
A1	0.00	0.05
A3	0.15REF	
D	1.35	1.45
E	1.75	1.85
b	0.15	0.25
L	0.30	0.50
L1	0.40	0.60
e	0.40 BSC	

Note:
1) Ref: JEDEC MO-248/236

Pericom Technology (Shanghai) Co.Ltd.
3/F., 20 Building, 481 Gui Ping Road,
Shanghai, 200233
Tel: (86-21)6485-0576. Fax: (86-21)6485-2181

DESCRIPTION: 10 Pin, UQFN, 1.4X1.8

PACKAGE CODE: ZM10

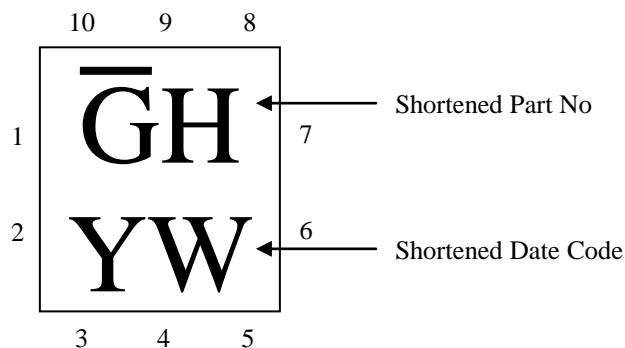
Marking Description

Ordering Information

Part Number	Packaging Code	Package
PI3A223ZME	ZM	Lead Free and Green UQFN-10

Notes:

- E = Pb-free and Green
- Adding X Suffix= Tape/Reel

Pericom Semiconductor Corporation • 1-800-435-2336 • www.pericom.com

Pericom reserves the right to make changes to its products or specifications at any time, without notice, in order to improve design or performance and to supply the best possible product. Pericom does not assume any responsibility for use of any circuitry described other than the circuitry embodied in Pericom product. The company makes no representations that circuitry described herein is free from patent infringement or other rights, of Pericom.

AMEYA360

Components Supply Platform

Authorized Distribution Brand :



Website :

Welcome to visit www.ameya360.com

Contact Us :

➤ Address :

401 Building No.5, JiuGe Business Center, Lane 2301, Yishan Rd
Minhang District, Shanghai , China

➤ Sales :

Direct +86 (21) 6401-6692

Email amall@ameya360.com

QQ 800077892

Skype [ameyasales1](#) [ameyasales2](#)

➤ Customer Service :

Email service@ameya360.com

➤ Partnership :

Tel +86 (21) 64016692-8333

Email mkt@ameya360.com