

DS31407

3-Input, 4-Output, Single DPLL Timing IC with Sub-ps Output Jitter

General Description

The DS31407 is a flexible, high-performance timing IC for diverse frequency conversion and frequency synthesis applications. On each of its three input clocks and four output clocks, the device can accept or generate nearly any frequency between 2kHz and 750MHz.

The input clocks are divided down, fractionally scaled as needed, and continuously monitored for activity and frequency accuracy. The best input clock is selected, manually or automatically, as the reference clock for the rest of the device. A flexible, high-performance digital PLL locks to the selected reference and provides programmable bandwidth, very high resolution holdover capability, and truly hitless switching between input clocks. The digital PLL is followed by a clock synthesis subsystem that has two fully programmable digital frequency synthesis blocks, a high-speed low-jitter APLL, and four output clocks, each with its own 32-bit divider and phase adjustment. The APLL provides fractional scaling and output jitter less than 1ps RMS.

For telecom systems, the DS31407 has all required features and functions to serve as a central timing function or as a line card timing IC. With a suitable oscillator the DS31407 meets the requirements of Stratum 2, 3E, 3, 4E, and 4, G.812 Types I-IV, G.813, and G.8262.

Applications

Frequency Conversion Applications in a Wide Variety of Equipment Types

Telecom Line Cards or Timing Cards with Any Mix of SONET/SDH, Synchronous Ethernet and/or OTN Ports in WAN Equipment Including MSPPs, Ethernet Switches, Routers, DSLAMs, and Base Stations

Ordering Information

PART	TEMP RANGE	PIN-PACKAGE
DS31407GN+	-40°C to +85°C	256 CSBGA

+Denotes a lead(Pb)-free/RoHS-compliant package.
SPI is a trademark of Motorola, Inc.

Features

- ◆ **Three Input Clocks**
 - ◆ Differential or CMOS/TTL Format
 - ◆ Any Frequency from 2kHz to 750MHz
 - ◆ Fractional Scaling for 64B/66B and FEC Scaling (e.g., 64/66, 237/255, 238/255) or Any Other Downscaling Requirement
 - ◆ Continuous Input Clock Quality Monitoring
 - ◆ Automatic or Manual Clock Selection
 - ◆ Three 2/4/8kHz Frame Sync Inputs
- ◆ **High-Performance DPLL**
 - ◆ Hitless Reference Switching on Loss of Input
 - ◆ Automatic or Manual Phase Build-Out
 - ◆ Holdover on Loss of All Inputs
 - ◆ Programmable Bandwidth, 0.5mHz to 400Hz
- ◆ **Two Digital Frequency Synthesizers**
 - ◆ Produce Any 2kHz Multiple Up to 77.76MHz
 - ◆ Per-DFS Clock Phase Adjust
- ◆ **High-Performance Output APLL**
 - ◆ Output Frequencies to 750MHz
 - ◆ High Resolution Fractional Scaling for FEC and 64B/66B (e.g., 255/237, 255/238, 66/64) or Any Other Scaling Requirement
 - ◆ Less than 1ps RMS Output Jitter
- ◆ **Four Output Clocks in Two Groups**
 - ◆ Nearly Any Frequency from < 1Hz to 750MHz
 - ◆ Each Group Slaves to a DFS Clock, an APLL Clock, or Any Input Clock (Divided and Scaled)
 - ◆ Each Has a Differential Output (1 CML, 1 LVDS/LVPECL) and Separate CMOS/TTL Output
 - ◆ 32-Bit Frequency Divider Per Output
 - ◆ Two Sync Pulse Outputs: 8kHz and 2kHz
- ◆ **General Features**
 - ◆ Suitable Line Card IC or Timing Card IC for Stratum 2/3E/3/4E/4, SMC, SEC/EEC, or SSU
 - ◆ Accepts and Produces Nearly Any Frequency Up to 750MHz Including 1Hz, 2kHz, 8kHz, NxDS1, Nx E1, DS2/J2, DS3, E3, 2.5M, 25M, 125M, 156.25M, and Nx19.44M Up to 622.08M
 - ◆ Internal Compensation for Local Oscillator Frequency Error
 - ◆ SPI™ Processor Interface
 - ◆ 1.8V Operation with 3.3V I/O (5V Tolerant)

Application Example

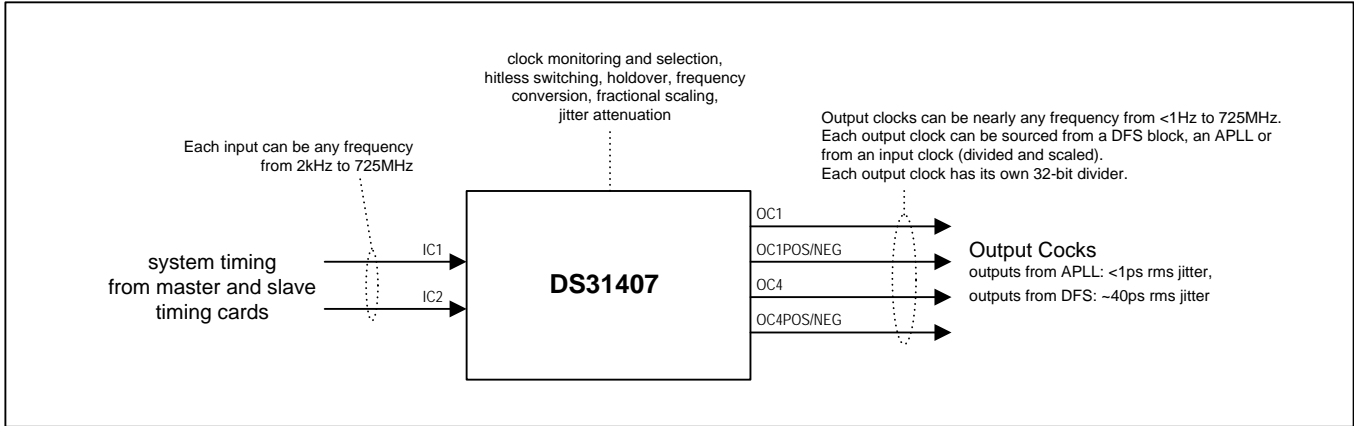

Block Diagram

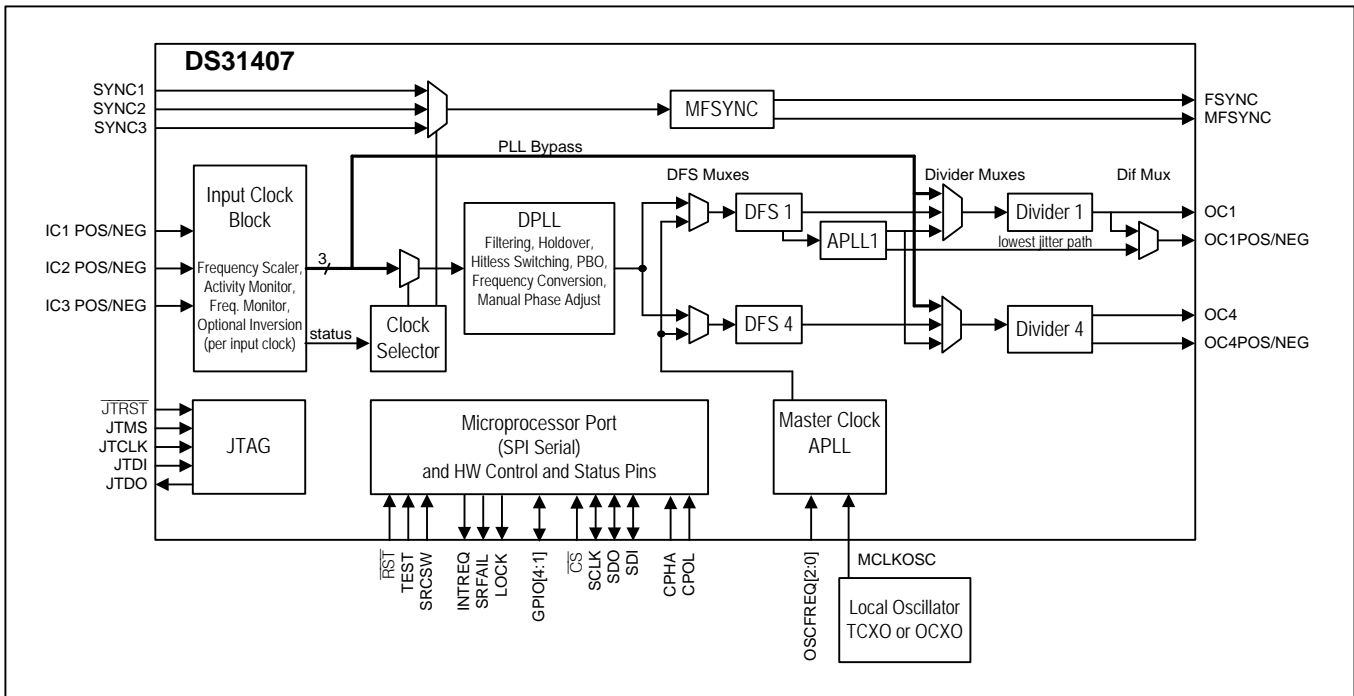

Detailed Features

Input Clock Features

- Three input clocks, differential or CMOS/TTL signal format
- Input clocks can be any frequency from 2kHz up to 750MHz
- Supported telecom frequencies include PDH, SDH, Synchronous Ethernet, OTU-1, OTU-2, OTU-3
- Per-input fractional scaling (i.e. multiplying by $N \div D$ where N is a 16-bit integer and D is a 32-bit integer and $N < D$) to undo 64B/66B and FEC scaling (e.g., 64/66, 238/255, 237/255, 236/255)
- Special mode allows locking to 1Hz input clocks
- All inputs constantly monitored by programmable activity monitors and frequency monitors
- Fast activity monitor can disqualify the selected reference after a few missing clock cycles
- Frequency measurement and frequency monitor thresholds with 0.2ppm resolution
- Three optional 2/4/8kHz frame-sync inputs

DPLL Features

- Very high-resolution DPLL architecture
- Sophisticated state machine automatically transitions between free-run, locked, and holdover states
- Revertive or nonrevertive reference selection algorithm
- Programmable bandwidth from 0.5mHz to 400Hz
- Separately configurable acquisition bandwidth and locked bandwidth
- Programmable damping factor: 1.2, 2.5, 5, 10, or 20
- Multiple phase detectors: phase/frequency and multicycle
- Phase/frequency locking ($\pm 360^\circ$ capture) or nearest edge phase locking ($\pm 180^\circ$ capture)
- Multicycle phase detection and locking (up to ± 8191 UI) improves jitter tolerance and lock time
- Phase build-out in response to reference switching for true hitless switching
- Less than 1 ns output clock phase transient during phase build-out
- Output phase adjustment up to ± 200 ns in 6ps steps with respect to selected input reference
- High-resolution frequency and phase measurement
- Holdover frequency averaging over 1-second, 5.8-minute, and 93.2-minute intervals
- Fast detection of input clock failure and transition to holdover mode
- Low-jitter frame sync (8kHz) and multiframe sync (2kHz) aligned with output clocks

Digital Frequency Synthesizer Features

- Two independently programmable DFS engines
- Each DFS can synthesize any 2kHz multiple up to 77.76MHz
- Per-DFS phase adjust (1/256UI steps)
- Approximately 40ps RMS output jitter

Output APLL Features

- Simultaneously produce four different output frequencies from the same reference clock
- Standard telecom output frequencies include 622.08MHz, 155.52MHz, and 19.44MHz for SONET/SDH and 156.25MHz, 125MHz, and 25MHz for Synchronous Ethernet
- Very high-resolution fractional scaling (i.e., noninteger multiplication)
- Less than 1ps RMS output jitter

Output Clock Features

- Four output clock signals in two groups
- Output clock group OC1 has a very high-speed differential output (current-mode logic, $\leq 750\text{MHz}$) and a separate CMOS/TTL output ($\leq 125\text{MHz}$)
- Output clock group OC4 has a high-speed differential output (LVDS/LVPECL, $\leq 312.5\text{MHz}$) and a separate CMOS/TTL output ($\leq 125\text{MHz}$)
- Each output can be any frequency from $< 1\text{Hz}$ to max frequency stated above
- Supported telecom frequencies include PDH, SDH, Synchronous Ethernet, OTN, microprocessor clock frequencies, and much more
- Internal clock muxing allows each output group to slave to its associated DFS block, an APLL output, or any input clock (after being divided and scaled)
- Outputs sourced directly from the APLL have less than 1ps RMS output jitter
- Outputs sourced directly from DFS blocks have approximately 40ps RMS output jitter
- Optional 32-bit frequency divider per output
- 8kHz frame sync and 2kHz multiframe sync outputs have programmable polarity and pulse width and can be disciplined by a 2kHz or 8kHz frame sync input
- Per-output delay adjustment
- Per-output enable/disable
- All outputs disabled during reset

General Features

- SPI serial microprocessor interface
- Four general-purpose I/O pins
- Register set can be write protected
- Operates from a 12.8MHz, 25.6MHz, 10.24MHz, 20.48MHz, 10MHz, 20MHz, 19.44MHz, or 38.88MHz local oscillator
- On-chip watchdog circuit for the local oscillator
- Internal compensation for local oscillator frequency error



Microsemi Corporate Headquarters
One Enterprise, Aliso Viejo CA 92656 USA
Within the USA: +1 (949) 380-6100
Sales: +1 (949) 380-6136
Fax: +1 (949) 215-4996

Microsemi Corporation (NASDAQ: MSCC) offers a comprehensive portfolio of semiconductor solutions for: aerospace, defense and security; enterprise and communications; and industrial and alternative energy markets. Products include high-performance, high-reliability analog and RF devices, mixed signal and RF integrated circuits, customizable SoCs, FPGAs, and complete subsystems. Microsemi is headquartered in Aliso Viejo, Calif. Learn more at www.microsemi.com.

© 2012 Microsemi Corporation. All rights reserved. Microsemi and the Microsemi logo are trademarks of Microsemi Corporation. All other trademarks and service marks are the property of their respective owners.

AMEYA360

Components Supply Platform

Authorized Distribution Brand :



Website :

Welcome to visit www.ameya360.com

Contact Us :

➤ Address :

401 Building No.5, JiuGe Business Center, Lane 2301, Yishan Rd
Minhang District, Shanghai , China

➤ Sales :

Direct +86 (21) 6401-6692

Email amall@ameya360.com

QQ 800077892

Skype [ameyasales1](#) [ameyasales2](#)

➤ Customer Service :

Email service@ameya360.com

➤ Partnership :

Tel +86 (21) 64016692-8333

Email mkt@ameya360.com