



# ATmega16M1/ATmega32M1/ATmega64M1/ ATmega32C1/ATmega64C1 Automotive

## 8-bit Microcontroller with 16K/32K/64K Bytes In-system Programmable Flash

### SUMMARY DATASHEET

#### Features

- High performance, low power AVR<sup>®</sup> 8-bit microcontroller
- Advanced RISC architecture
  - 131 powerful instructions - most single clock cycle execution
  - 32 × 8 general purpose working registers
  - Fully static operation
  - Up to 1MIPS throughput per MHz
  - On-chip 2-cycle multiplier
- Data and non-volatile program memory
  - 16K/32K/64K bytes flash of in-system programmable program memory
    - Endurance: 10,000 write/erase cycles
  - Optional boot code section with independent lock bits
  - In-system programming by on-chip boot program
    - True read-while-write operation
  - 512/1024/2048 bytes of in-system programmable EEPROM
    - Endurance: 100,000 write/erase cycles
- Programming lock for flash program and EEPROM data security
- 1024/2048/4096 bytes internal SRAM
- On chip debug interface (debugWIRE)
- CAN 2.0A/B with 6 message objects - ISO 16845 certified <sup>(1)</sup>
- LIN 2.1 and 1.3 controller or 8-Bit UART
- One 12-bit high speed PSC (power stage controller) (only ATmega16/32/64M1)
  - Non overlapping inverted PWM output pins with flexible dead-time
  - Variable PWM duty cycle and frequency
  - Synchronous update of all PWM registers
  - Auto stop function for emergency event
- Peripheral features
  - One 8-bit general purpose Timer/Counter with separate prescaler, compare mode and capture mode
  - One 16-bit general purpose Timer/Counter with separate prescaler, compare mode and capture mode

This is a summary document.  
The complete document is  
available on the Atmel website  
at [www.atmel.com](http://www.atmel.com).

1. See certification on Atmel<sup>®</sup> web site.

- One master/slave SPI serial interface
- 10-bit ADC
  - Up To 11 single ended channels and 3 fully differential ADC channel pairs
  - Programmable gain (5x, 10x, 20x, 40x) on differential channels
  - Internal reference voltage
  - Direct power supply voltage measurement
- 10-bit DAC for variable voltage reference (comparators, ADC)
- Four analog comparators with variable threshold detection
- 100µA ±6% current source (LIN node identification)
- Interrupt and wake-up on pin change
- Programmable watchdog timer with separate on-chip oscillator
- On-chip temperature sensor
- Special microcontroller features
  - Low power idle, noise reduction, and power down modes
  - Power on reset and programmable brown out detection
  - In-system programmable via SPI port
  - High precision crystal oscillator for CAN operations (16MHz)
    - Internal calibrated RC oscillator (8MHz)
    - On-chip PLL for fast PWM (32MHz, 64MHz) and CPU (16MHz) (only ATmega16/32/64M1)
  - Operating voltage:
    - 2.7V - 5.5V
  - Extended operating temperature:
    - -40°C to +125°C
  - Core speed grade:
    - 0 - 8MHz at 2.7 - 4.5V
    - 0 - 16MHz at 4.5 - 5.5V

**Table 1. ATmega32/64/M1/C1 Product Line-up**

Part Number	ATmega32C1	ATmega64C1	ATmega16M1	ATmega32M1	ATmega64M1
Flash size	32 Kbyte	64 Kbyte	16 Kbyte	32 Kbyte	64 Kbyte
RAM size	2048 bytes	4096 bytes	1024 bytes	2048 bytes	4096 bytes
EEPROM size	1024 bytes	2048 bytes	512 bytes	1024 bytes	2048 bytes
8-bit timer	Yes				
16-bit timer	Yes				
PSC	No		Yes		
PWM outputs	4	4	10	10	10
Fault inputs (PSC)	0	0	3	3	3
PLL	No		Yes		
10-bit ADC channels	11 single 3 differential				
10-bit DAC	Yes				
Analog comparators	4				
Current source	Yes				
CAN	Yes				
LIN/UART	Yes				
On-chip temp. sensor	Yes				
SPI interface	Yes				

# 1. Pin Configurations

Figure 1-1. ATmega16/32/64M1 TQFP32/QFN32 (7\*7mm) Package

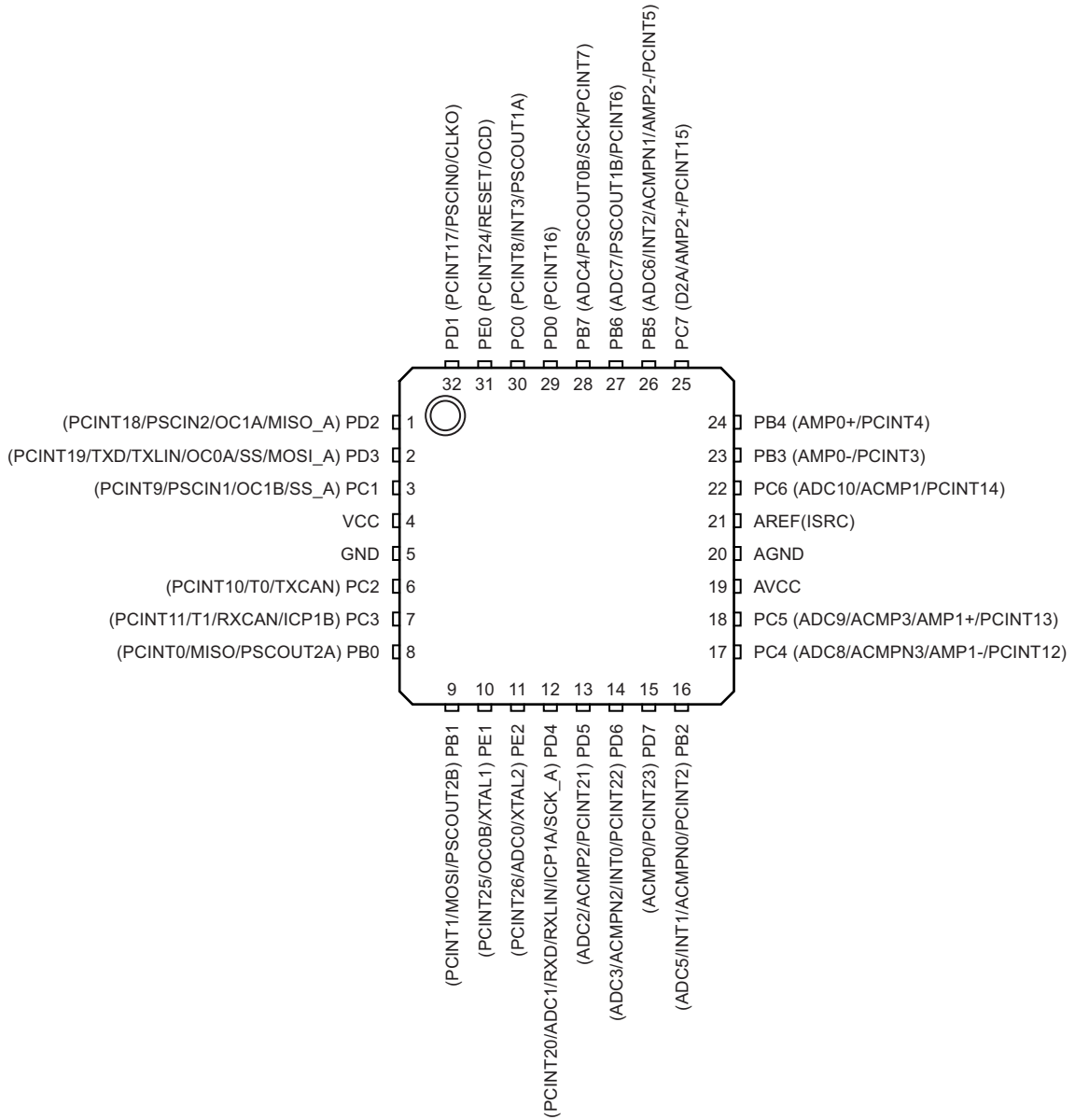

Note: On the engineering samples (parts marked AT90PWM324), the ACMPN3 alternate function is not located on PC4. It is located on PE2.

Figure 1-2. ATmega32/64C1 TQFP32/QFN32 (7\*7mm) Package

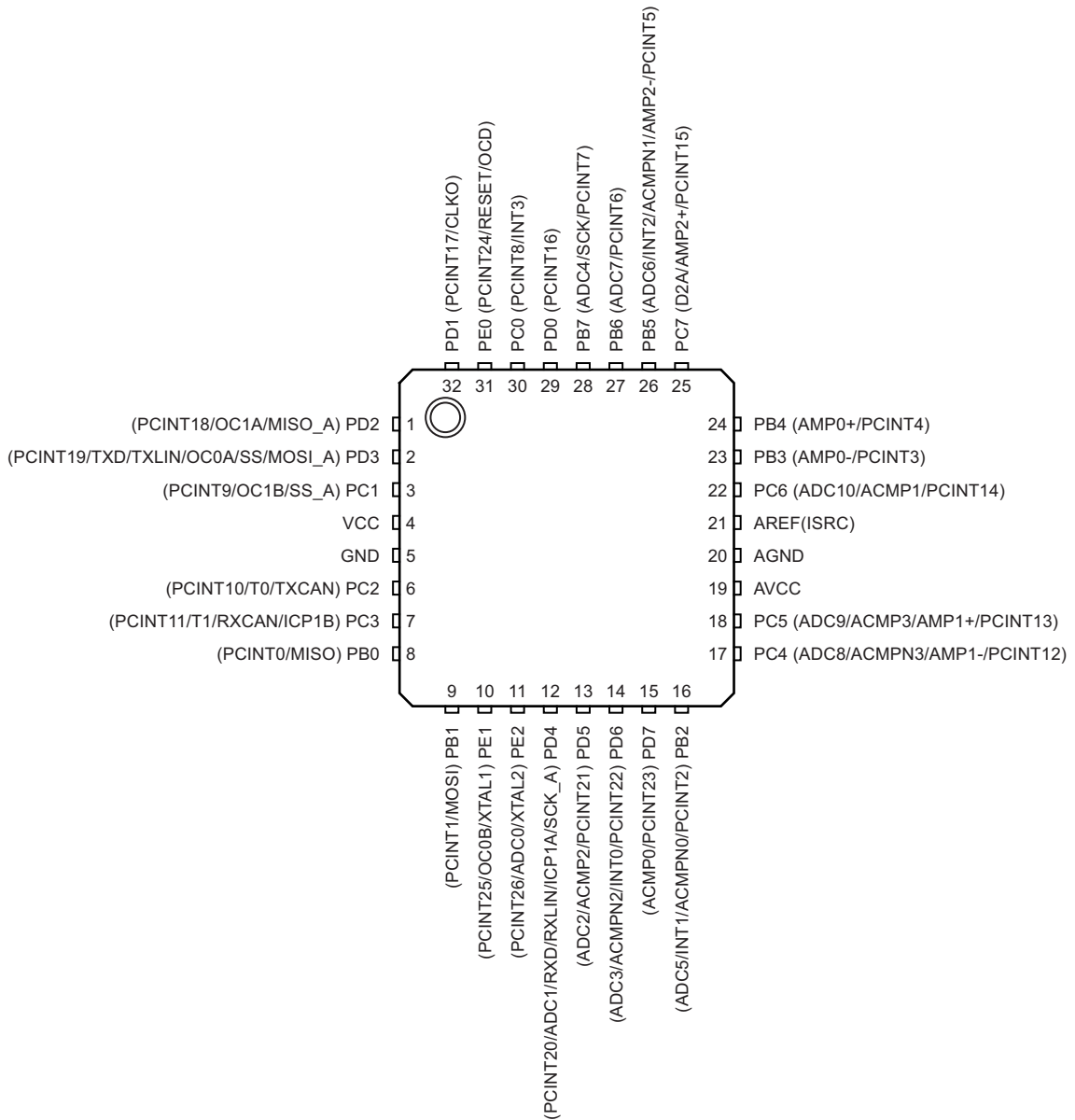

Note: On the first engineering samples (parts marked AT90PWM324), the ACMPN3 alternate function is not located on PC4. It is located on PE2.

## 1.1 Pin Descriptions

Table 1-1. Pin-out Description

QFN32 Pin Number	Mnemonic	Type	Name, Function and Alternate Function
5	GND	Power	<b>Ground:</b> 0V reference
20	AGND	Power	<b>Analog Ground:</b> 0V reference for analog part
4	VCC	Power	Power supply
19	AVCC	Power	<b>Analog Power Supply:</b> This is the power supply voltage for analog part For a normal use this pin must be connected.
21	AREF	Power	<b>Analog Reference:</b> Reference for analog converter. This is the reference voltage of the A/D converter. As output, can be used by external analog ISRC (Current Source Output)
8	PB0	I/O	MISO (SPI Master In Slave Out) PSCOUT2A (PSC Module 2 Output A) PCINT0 (Pin Change Interrupt 0)
9	PB1	I/O	MOSI (SPI Master Out Slave In) PSCOUT2B (PSC Module 2 Output B) PCINT1 (Pin Change Interrupt 1)
16	PB2	I/O	ADC5 (Analog Input Channel 5) INT1 (External Interrupt 1 Input) ACMPN0 (Analog Comparator 0 Negative Input) PCINT2 (Pin Change Interrupt 2)
23	PB3	I/O	AMP0- (Analog Differential Amplifier 0 Negative Input) PCINT3 (Pin Change Interrupt 3)
24	PB4	I/O	AMP0+ (Analog Differential Amplifier 0 Positive Input) PCINT4 (Pin Change Interrupt 4)
26	PB5	I/O	ADC6 (Analog Input Channel 6) INT2 (External Interrupt 2 Input) ACMPN1 (Analog Comparator 1 Negative Input) AMP2- (Analog Differential Amplifier 2 Negative Input) PCINT5 (Pin Change Interrupt 5)
27	PB6	I/O	ADC7 (Analog Input Channel 7) PSCOUT1B (PSC Module 1 Output A) PCINT6 (Pin Change Interrupt 6)
28	PB7	I/O	ADC4 (Analog Input Channel 4) PSCOUT0B (PSC Module 0 Output B) SCK (SPI Clock) PCINT7 (Pin Change Interrupt 7)
30	PC0	I/O	PSCOUT1A (PSC Module 1 Output A) INT3 (External Interrupt 3 Input) PCINT8 (Pin Change Interrupt 8)

Note: 1. On the first engineering samples (parts marked AT90PWM324), the ACMPN3 alternate function is not located on PC4. It is located on PE2.

**Table 1-1. Pin-out Description (Continued)**

QFN32 Pin Number	Mnemonic	Type	Name, Function and Alternate Function
3	PC1	I/O	PSCIN1 (PSC Digital Input 1) OC1B (Timer 1 Output Compare B) SS_A (Alternate SPI Slave Select) PCINT9 (Pin Change Interrupt 9)
6	PC2	I/O	T0 (Timer 0 clock input) TXCAN (CAN Transmit Output) PCINT10 (Pin Change Interrupt 10)
7	PC3	I/O	T1 (Timer 1 clock input) RXCAN (CAN Receive Input) ICP1B (Timer 1 input capture alternate B input) PCINT11 (Pin Change Interrupt 11)
17	PC4	I/O	ADC8 (Analog Input Channel 8) AMP1- (Analog Differential Amplifier 1 Negative Input) ACMPN3 (Analog Comparator 3 Negative Input) PCINT12 (Pin Change Interrupt 12)
18	PC5	I/O	ADC9 (Analog Input Channel 9) AMP1+ (Analog Differential Amplifier 1 Positive Input) ACMP3 (Analog Comparator 3 Positive Input) PCINT13 (Pin Change Interrupt 13)
22	PC6	I/O	ADC10 (Analog Input Channel 10) ACMP1 (Analog Comparator 1 Positive Input) PCINT14 (Pin Change Interrupt 14)
25	PC7	I/O	D2A (DAC output) AMP2+ (Analog Differential Amplifier 2 Positive Input) PCINT15 (Pin Change Interrupt 15)
29	PD0	I/O	PSCOUT0A (PSC Module 0 Output A) PCINT16 (Pin Change Interrupt 16)
32	PD1	I/O	PSCIN0 (PSC Digital Input 0) CLKO (System Clock Output) PCINT17 (Pin Change Interrupt 17)
1	PD2	I/O	OC1A (Timer 1 Output Compare A) PSCIN2 (PSC Digital Input 2) MISO_A (Programming & alternate SPI Master In Slave Out) PCINT18 (Pin Change Interrupt 18)
2	PD3	I/O	TXD (UART Tx data) TXLIN (LIN Transmit Output) OC0A (Timer 0 Output Compare A) SS (SPI Slave Select) MOSI_A (Programming & alternate Master Out SPI Slave In) PCINT19 (Pin Change Interrupt 19)

Note: 1. On the first engineering samples (parts marked AT90PWM324), the ACMPN3 alternate function is not located on PC4. It is located on PE2.

**Table 1-1. Pin-out Description (Continued)**

QFN32 Pin Number	Mnemonic	Type	Name, Function and Alternate Function
12	PD4	I/O	ADC1 (Analog Input Channel 1) RXD (UART Rx data) RXLIN (LIN Receive Input) ICP1A (Timer 1 input capture alternate A input) SCK_A (Programming & alternate SPI Clock) PCINT20 (Pin Change Interrupt 20)
13	PD5	I/O	ADC2 (Analog Input Channel 2) ACMP2 (Analog Comparator 2 Positive Input) PCINT21 (Pin Change Interrupt 21)
14	PD6	I/O	ADC3 (Analog Input Channel 3) ACMPN2 (Analog Comparator 2 Negative Input) INT0 (External Interrupt 0 Input) PCINT22 (Pin Change Interrupt 22)
15	PD7	I/O	ACMP0 (Analog Comparator 0 Positive Input) PCINT23 (Pin Change Interrupt 23)
31	PE0	I/O or I	RESET (Reset Input) OCD (On Chip Debug I/O) PCINT24 (Pin Change Interrupt 24)
10	PE1	I/O	XTAL1 (XTAL Input) OC0B (Timer 0 Output Compare B) PCINT25 (Pin Change Interrupt 25)
11	PE2	I/O	XTAL2 (XTAL Output) ADC0 (Analog Input Channel 0) PCINT26 (Pin Change Interrupt 26)

Note: 1. On the first engineering samples (parts marked AT90PWM324), the ACMPN3 alternate function is not located on PC4. It is located on PE2.

## 2. Overview

The Atmel® ATmega16/32/64/M1/C1 is a low-power CMOS 8-bit microcontroller based on the AVR enhanced RISC architecture. By executing powerful instructions in a single clock cycle, the Atmel ATmega16/32/64/M1/C1 achieves throughputs approaching 1MIPS per MHz allowing the system designer to optimize power consumption versus processing speed.

### 2.1 Block Diagram

Figure 2-1. Block Diagram

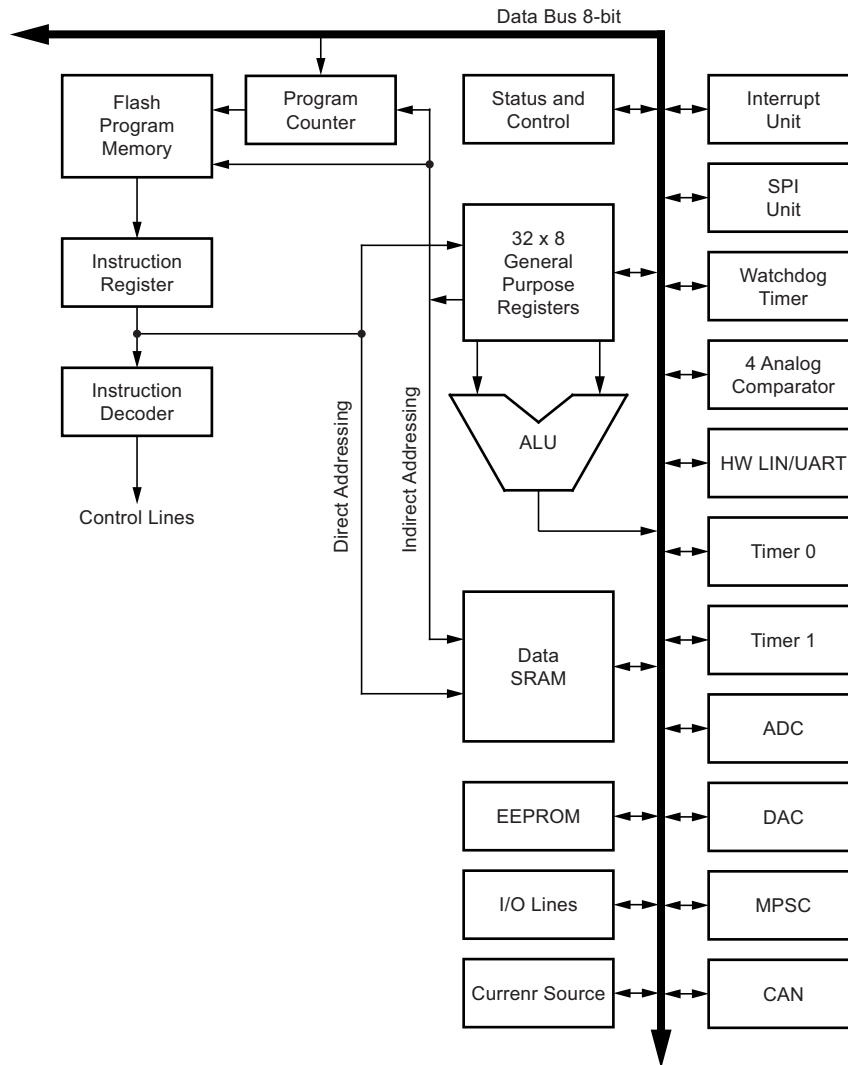

The AVR® core combines a rich instruction set with 32 general purpose working registers. All the 32 registers are directly connected to the Arithmetic Logic Unit (ALU), allowing two independent registers to be accessed in one single instruction executed in one clock cycle. The resulting architecture is more code efficient while achieving throughputs up to ten times faster than conventional CISC microcontrollers.



The Atmel® ATmega16/32/64/M1/C1 provides the following features: 16K/32K/64K bytes of in-system programmable flash with read-while-write capabilities, 512/1024/2048 bytes EEPROM, 1024/2048/4096 bytes SRAM, 27 general purpose I/O lines, 32 general purpose working registers, one motor power stage controller, two flexible Timer/Counters with compare modes and PWM, one UART with HW LIN, an 11-channel 10-bit ADC with two differential input stages with programmable gain, a 10-bit DAC, a programmable watchdog timer with internal individual oscillator, an SPI serial port, an on-chip debug system and four software selectable power saving modes.

The idle mode stops the CPU while allowing the SRAM, Timer/Counters, SPI ports, CAN, LIN/UART and interrupt system to continue functioning. The power-down mode saves the register contents but freezes the oscillator, disabling all other chip functions until the next interrupt or hardware reset. The ADC noise reduction mode stops the CPU and all I/O modules except ADC, to minimize switching noise during ADC conversions. In standby mode, the crystal/resonator oscillator is running while the rest of the device is sleeping. This allows very fast start-up combined with low power consumption.

The device is manufactured using Atmel's high-density nonvolatile memory technology. The on-chip ISP flash allows the program memory to be reprogrammed in-system through an SPI serial interface, by a conventional nonvolatile memory programmer, or by an on-chip boot program running on the AVR core. The boot program can use any interface to download the application program in the application flash memory. Software in the boot flash section will continue to run while the application flash section is updated, providing true read-while-write operation. By combining an 8-bit RISC CPU with in-system self-programmable flash on a monolithic chip, the Atmel ATmega16/32/64/M1/C1 is a powerful microcontroller that provides a highly flexible and cost effective solution to many embedded control applications.

The ATmega16/32/64/M1/C1 AVR® is supported with a full suite of program and system development tools including: C compilers, macro assemblers, program debugger/simulators, in-circuit emulators, and evaluation kits.

## 2.2 Automotive Quality Grade

The Atmel ATmega16/32/64/M1/C1 have been developed and manufactured according to the most stringent requirements of the international standard ISO-TS-16949. This data sheet contains limit values extracted from the results of extensive characterization (Temperature and Voltage). The quality and reliability of the ATmega16/32/64/M1/C1 have been verified during regular product qualification as per AEC-Q100 grade 1.

As indicated in the ordering information paragraph, the products are available in only one temperature grade.

**Table 2-1. Temperature Grade Identification for Automotive Products**

Temperature	Temperature Identifier	Comments
-40°C; +125°C	Z	Full automotive temperature range

## 2.3 Pin Descriptions

### 2.3.1 VCC

Digital supply voltage.

### 2.3.2 GND

Ground.

### 2.3.3 Port B (PB7..PB0)

Port B is an 8-bit bi-directional I/O port with internal pull-up resistors (selected for each bit). The port B output buffers have symmetrical drive characteristics with both high sink and source capability. As inputs, port B pins that are externally pulled low will source current if the pull-up resistors are activated. The port B pins are tri-stated when a reset condition becomes active, even if the clock is not running.

Port B also serves the functions of various special features of the ATmega16/32/64/M1/C1.

### 2.3.4 Port C (PC7..PC0)

Port C is an 8-bit bi-directional I/O port with internal pull-up resistors (selected for each bit). The port C output buffers have symmetrical drive characteristics with both high sink and source capability. As inputs, port C pins that are externally pulled low will source current if the pull-up resistors are activated. The port C pins are tri-stated when a reset condition becomes active, even if the clock is not running.

Port C also serves the functions of special features of the Atmel® ATmega16/32/64/M1/C1.

### 2.3.5 Port D (PD7..PD0)

Port D is an 8-bit bi-directional I/O port with internal pull-up resistors (selected for each bit). The port D output buffers have symmetrical drive characteristics with both high sink and source capability. As inputs, port D pins that are externally pulled low will source current if the pull-up resistors are activated. The port D pins are tri-stated when a reset condition becomes active, even if the clock is not running.

Port D also serves the functions of various special features of the Atmel ATmega16/32/64/M1/C1.

### 2.3.6 Port E (PE2..0) RESET/ XTAL1/ XTAL2

Port E is a 3-bit bi-directional I/O port with internal pull-up resistors (selected for each bit). The port E output buffers have symmetrical drive characteristics with both high sink and source capability. As inputs, port E pins that are externally pulled low will source current if the pull-up resistors are activated. The port E pins are tri-stated when a reset condition becomes active, even if the clock is not running.

If the RSTDISBL fuse is programmed, PE0 is used as an I/O pin. Note that the electrical characteristics of PE0 differ from those of the other pins of port E.

If the RSTDISBL fuse is unprogrammed, PE0 is used as a reset input. A low level on this pin for longer than the minimum pulse length will generate a reset, even if the clock is not running.

Depending on the clock selection fuse settings, PE1 can be used as input to the inverting oscillator amplifier and input to the internal clock operating circuit.

Depending on the clock selection fuse settings, PE2 can be used as output from the inverting oscillator amplifier.

### 2.3.7 AVCC

AVCC is the supply voltage pin for the A/D converter, D/A converter, current source. It should be externally connected to  $V_{CC}$ , even if the ADC, DAC are not used. If the ADC is used, it should be connected to  $V_{CC}$  through a low-pass filter.

### 2.3.8 AREF

This is the analog reference pin for the A/D converter.

## 2.4 About Code Examples

This documentation contains simple code examples that briefly show how to use various parts of the device. These code examples assume that the part specific header file is included before compilation. Be aware that not all C compiler vendors include bit definitions in the header files and interrupt handling in C is compiler dependent. Please confirm with the C compiler documentation for more details.

### 3. Instruction Set Summary

Mnemonics	Operands	Description	Operation	Flags	#Clocks
<b>Arithmetic and Logic Instructions</b>					
ADD	Rd, Rr	Add two registers	$Rd \leftarrow Rd + Rr$	Z, C, N, V, H	1
ADC	Rd, Rr	Add with carry two registers	$Rd \leftarrow Rd + Rr + C$	Z, C, N, V, H	1
ADIW	RdI,K	Add immediate to word	$Rdh:Rdl \leftarrow Rdh:Rdl + K$	Z, C, N, V, S	2
SUB	Rd, Rr	Subtract two registers	$Rd \leftarrow Rd - Rr$	Z, C, N, V, H	1
SUBI	Rd, K	Subtract constant from register	$Rd \leftarrow Rd - K$	Z, C, N, V, H	1
SBC	Rd, Rr	Subtract with carry two registers	$Rd \leftarrow Rd - Rr - C$	Z, C, N, V, H	1
SBCI	Rd, K	Subtract with carry constant from reg.	$Rd \leftarrow Rd - K - C$	Z, C, N, V, H	1
SBIW	RdI,K	Subtract immediate from word	$Rdh:Rdl \leftarrow Rdh:Rdl - K$	Z, C, N, V, S	2
AND	Rd, Rr	Logical AND registers	$Rd \leftarrow Rd \times Rr$	Z, N, V	1
ANDI	Rd, K	Logical AND register and constant	$Rd \leftarrow Rd \times K$	Z, N, V	1
OR	Rd, Rr	Logical OR registers	$Rd \leftarrow Rd \vee Rr$	Z, N, V	1
ORI	Rd, K	Logical OR register and constant	$Rd \leftarrow Rd \vee K$	Z, N, V	1
EOR	Rd, Rr	Exclusive OR registers	$Rd \leftarrow Rd \oplus Rr$	Z, N, V	1
COM	Rd	One's complement	$Rd \leftarrow 0xFF - Rd$	Z, C, N, V	1
NEG	Rd	Two's complement	$Rd \leftarrow 0x00 - Rd$	Z, C, N, V, H	1
SBR	Rd,K	Set bit(s) in register	$Rd \leftarrow Rd \vee K$	Z, N, V	1
CBR	Rd,K	Clear bit(s) in register	$Rd \leftarrow Rd \cdot (0xFF - K)$	Z, N, V	1
INC	Rd	Increment	$Rd \leftarrow Rd + 1$	Z, N, V	1
DEC	Rd	Decrement	$Rd \leftarrow Rd - 1$	Z, N, V	1
TST	Rd	Test for zero or minus	$Rd \leftarrow Rd \times Rd$	Z, N, V	1
CLR	Rd	Clear register	$Rd \leftarrow Rd \oplus Rd$	Z, N, V	1
SER	Rd	Set register	$Rd \leftarrow 0xFF$	None	1
MUL	Rd, Rr	Multiply unsigned	$R1:R0 \leftarrow Rd \times Rr$	Z, C	2
MULS	Rd, Rr	Multiply signed	$R1:R0 \leftarrow Rd \times Rr$	Z, C	2
MULSU	Rd, Rr	Multiply signed with unsigned	$R1:R0 \leftarrow Rd \times Rr$	Z, C	2
FMUL	Rd, Rr	Fractional multiply unsigned	$R1:R0 \leftarrow (Rd \times Rr) \ll 1$	Z, C	2
FMULS	Rd, Rr	Fractional multiply signed	$R1:R0 \leftarrow (Rd \times Rr) \ll 1$	Z, C	2
FMULSU	Rd, Rr	Fractional multiply signed with unsigned	$R1:R0 \leftarrow (Rd \times Rr) \ll 1$	Z, C	2
<b>Branch Instructions</b>					
RJMP	k	Relative jump	$PC \leftarrow PC + k + 1$	None	2
IJMP		Indirect jump to (Z)	$PC \leftarrow Z$	None	2
JMP(*)	k	Direct jump	$PC \leftarrow k$	None	3
RCALL	k	Relative subroutine call	$PC \leftarrow PC + k + 1$	None	3
ICALL		Indirect call to (Z)	$PC \leftarrow Z$	None	3
CALL(*)	k	Direct subroutine call	$PC \leftarrow k$	None	4
RET		Subroutine return	$PC \leftarrow STACK$	None	4
RETI		Interrupt return	$PC \leftarrow STACK$	I	4
CPSE	Rd,Rr	Compare, skip if equal	if (Rd = Rr) $PC \leftarrow PC + 2$ or 3	None	1/2/3

Note: 1. These Instructions are only available in "16K and 32K parts"

### 3. Instruction Set Summary (Continued)

Mnemonics	Operands	Description	Operation	Flags	#Clocks
CP	Rd,Rr	Compare	$Rd - Rr$	Z, N, V, C, H	1
CPC	Rd,Rr	Compare with carry	$Rd - Rr - C$	Z, N, V, C, H	1
CPI	Rd,K	Compare register with immediate	$Rd - K$	Z, N, V, C, H	1
SBRC	Rr, b	Skip if bit in register cleared	if (Rr(b)=0) $PC \leftarrow PC + 2$ or 3	None	1/2/3
SBRS	Rr, b	Skip if bit in register is set	if (Rr(b)=1) $PC \leftarrow PC + 2$ or 3	None	1/2/3
SBIC	P, b	Skip if bit in I/O register cleared	if (P(b)=0) $PC \leftarrow PC + 2$ or 3	None	1/2/3
SBIS	P, b	Skip if bit in I/O register is set	if (P(b)=1) $PC \leftarrow PC + 2$ or 3	None	1/2/3
BRBS	s, k	Branch if status flag Set	if (SREG(s) = 1) then $PC \leftarrow PC + k + 1$	None	1/2
BRBC	s, k	Branch if status flag cleared	if (SREG(s) = 0) then $PC \leftarrow PC + k + 1$	None	1/2
BREQ	k	Branch if equal	if (Z = 1) then $PC \leftarrow PC + k + 1$	None	1/2
BRNE	k	Branch if not equal	if (Z = 0) then $PC \leftarrow PC + k + 1$	None	1/2
BRCS	k	Branch if carry set	if (C = 1) then $PC \leftarrow PC + k + 1$	None	1/2
BRCC	k	Branch if carry cleared	if (C = 0) then $PC \leftarrow PC + k + 1$	None	1/2
BRSH	k	Branch if same or higher	if (C = 0) then $PC \leftarrow PC + k + 1$	None	1/2
BRLO	k	Branch if lower	if (C = 1) then $PC \leftarrow PC + k + 1$	None	1/2
BRMI	k	Branch if minus	if (N = 1) then $PC \leftarrow PC + k + 1$	None	1/2
BRPL	k	Branch if plus	if (N = 0) then $PC \leftarrow PC + k + 1$	None	1/2
BRGE	k	Branch if greater or equal, signed	if ( $N \oplus V = 0$ ) then $PC \leftarrow PC + k + 1$	None	1/2
BRLT	k	Branch if less than zero, signed	if ( $N \oplus V = 1$ ) then $PC \leftarrow PC + k + 1$	None	1/2
BRHS	k	Branch if half carry flag set	if (H = 1) then $PC \leftarrow PC + k + 1$	None	1/2
BRHC	k	Branch if half carry flag cleared	if (H = 0) then $PC \leftarrow PC + k + 1$	None	1/2
BRTS	k	Branch if T flag set	if (T = 1) then $PC \leftarrow PC + k + 1$	None	1/2
BRTC	k	Branch if T flag cleared	if (T = 0) then $PC \leftarrow PC + k + 1$	None	1/2
BRVS	k	Branch if overflow flag is set	if (V = 1) then $PC \leftarrow PC + k + 1$	None	1/2
BRVC	k	Branch if overflow flag is cleared	if (V = 0) then $PC \leftarrow PC + k + 1$	None	1/2
BRIE	k	Branch if interrupt enabled	if (I = 1) then $PC \leftarrow PC + k + 1$	None	1/2
BRID	k	Branch if interrupt disabled	if (I = 0) then $PC \leftarrow PC + k + 1$	None	1/2
<b>Bit and Bit-test Instructions</b>					
SBI	P,b	Set bit in I/O register	$I/O(P,b) \leftarrow 1$	None	2
CBI	P,b	Clear bit in I/O register	$I/O(P,b) \leftarrow 0$	None	2
LSL	Rd	Logical shift left	$Rd(n+1) \leftarrow Rd(n), Rd(0) \leftarrow 0$	Z, C, N, V	1
LSR	Rd	Logical shift right	$Rd(n) \leftarrow Rd(n+1), Rd(7) \leftarrow 0$	Z, C, N, V	1
ROL	Rd	Rotate left through carry	$Rd(0) \leftarrow C, Rd(n+1) \leftarrow Rd(n), C \leftarrow Rd(7)$	Z, C, N, V	1
ROR	Rd	Rotate right through carry	$Rd(7) \leftarrow C, Rd(n) \leftarrow Rd(n+1), C \leftarrow Rd(0)$	Z, C, N, V	1
ASR	Rd	Arithmetic shift right	$Rd(n) \leftarrow Rd(n+1), n=0..6$	Z, C, N, V	1
SWAP	Rd	Swap nibbles	$Rd(3..0) \leftarrow Rd(7..4), Rd(7..4) \leftarrow Rd(3..0)$	None	1
BSET	s	Flag set	$SREG(s) \leftarrow 1$	SREG(s)	1
BCLR	s	Flag clear	$SREG(s) \leftarrow 0$	SREG(s)	1
BST	Rr, b	Bit store from register to T	$T \leftarrow Rr(b)$	T	1
BLD	Rd, b	Bit load from T to register	$Rd(b) \leftarrow T$	None	1

Note: 1. These instructions are only available in "16K and 32K parts"

### 3. Instruction Set Summary (Continued)

Mnemonics	Operands	Description	Operation	Flags	#Clocks
SEC		Set carry	$C \leftarrow 1$	C	1
CLC		Clear carry	$C \leftarrow 0$	C	1
SEN		Set negative flag	$N \leftarrow 1$	N	1
CLN		Clear negative flag	$N \leftarrow 0$	N	1
SEZ		Set zero flag	$Z \leftarrow 1$	Z	1
CLZ		Clear zero flag	$Z \leftarrow 0$	Z	1
SEI		Global interrupt enable	$I \leftarrow 1$	I	1
CLI		Global interrupt disable	$I \leftarrow 0$	I	1
SES		Set signed test flag	$S \leftarrow 1$	S	1
CLS		Clear signed test flag	$S \leftarrow 0$	S	1
SEV		Set twos complement overflow.	$V \leftarrow 1$	V	1
CLV		Clear twos complement overflow	$V \leftarrow 0$	V	1
SET		Set T in SREG	$T \leftarrow 1$	T	1
CLT		Clear T in SREG	$T \leftarrow 0$	T	1
SEH		Set half carry flag in SREG	$H \leftarrow 1$	H	1
CLH		Clear half carry flag in SREG	$H \leftarrow 0$	H	1
<b>Data Transfer Instructions</b>					
MOV	Rd, Rr	Move between registers	$Rd \leftarrow Rr$	None	1
MOVW	Rd, Rr	Copy register word	$Rd+1:Rd \leftarrow Rr+1:Rr$	None	1
LDI	Rd, K	Load immediate	$Rd \leftarrow K$	None	1
LD	Rd, X	Load indirect	$Rd \leftarrow (X)$	None	2
LD	Rd, X+	Load indirect and post-inc.	$Rd \leftarrow (X), X \leftarrow X + 1$	None	2
LD	Rd, -X	Load indirect and pre-dec.	$X \leftarrow X - 1, Rd \leftarrow (X)$	None	2
LD	Rd, Y	Load indirect	$Rd \leftarrow (Y)$	None	2
LD	Rd, Y+	Load indirect and post-inc.	$Rd \leftarrow (Y), Y \leftarrow Y + 1$	None	2
LD	Rd, -Y	Load indirect and pre-dec.	$Y \leftarrow Y - 1, Rd \leftarrow (Y)$	None	2
LDD	Rd, Y+q	Load indirect with displacement	$Rd \leftarrow (Y + q)$	None	2
LD	Rd, Z	Load indirect	$Rd \leftarrow (Z)$	None	2
LD	Rd, Z+	Load indirect and post-inc.	$Rd \leftarrow (Z), Z \leftarrow Z + 1$	None	2
LD	Rd, -Z	Load indirect and pre-dec.	$Z \leftarrow Z - 1, Rd \leftarrow (Z)$	None	2
LDD	Rd, Z+q	Load indirect with displacement	$Rd \leftarrow (Z + q)$	None	2
LDS	Rd, k	Load direct from SRAM	$Rd \leftarrow (k)$	None	2
ST	X, Rr	Store indirect	$(X) \leftarrow Rr$	None	2
ST	X+, Rr	Store indirect and post-inc.	$(X) \leftarrow Rr, X \leftarrow X + 1$	None	2
ST	-X, Rr	Store indirect and pre-dec.	$X \leftarrow X - 1, (X) \leftarrow Rr$	None	2
ST	Y, Rr	Store indirect	$(Y) \leftarrow Rr$	None	2
ST	Y+, Rr	Store indirect and post-inc.	$(Y) \leftarrow Rr, Y \leftarrow Y + 1$	None	2
ST	-Y, Rr	Store indirect and pre-dec.	$Y \leftarrow Y - 1, (Y) \leftarrow Rr$	None	2
STD	Y+q, Rr	Store indirect with displacement	$(Y + q) \leftarrow Rr$	None	2
ST	Z, Rr	Store indirect	$(Z) \leftarrow Rr$	None	2

Note: 1. These instructions are only available in "16K and 32K parts"

### 3. Instruction Set Summary (Continued)

Mnemonics	Operands	Description	Operation	Flags	#Clocks
ST	Z+, Rr	Store indirect and post-inc.	$(Z) \leftarrow Rr, Z \leftarrow Z + 1$	None	2
ST	-Z, Rr	Store indirect and pre-dec.	$Z \leftarrow Z - 1, (Z) \leftarrow Rr$	None	2
STD	Z+q,Rr	Store indirect with displacement	$(Z + q) \leftarrow Rr$	None	2
STS	k, Rr	Store direct to SRAM	$(k) \leftarrow Rr$	None	2
LPM		Load program memory	$R0 \leftarrow (Z)$	None	3
LPM	Rd, Z	Load program memory	$Rd \leftarrow (Z)$	None	3
LPM	Rd, Z+	Load program memory and post-inc	$Rd \leftarrow (Z), Z \leftarrow Z+1$	None	3
SPM		Store program memory	$(Z) \leftarrow R1:R0$	None	-
IN	Rd, P	In port	$Rd \leftarrow P$	None	1
OUT	P, Rr	Out port	$P \leftarrow Rr$	None	1
PUSH	Rr	Push register on stack	$STACK \leftarrow Rr$	None	2
POP	Rd	Pop register from stack	$Rd \leftarrow STACK$	None	2
<b>MCU Control Instructions</b>					
NOP		No operation		None	1
SLEEP		Sleep	(see specific descr. for sleep function)	None	1
WDR		Watchdog reset	(see specific descr. for WDR/timer)	None	1
BREAK		Break	For on-chip debug Only	None	N/A

Note: 1. These Instructions are only available in "16K and 32K parts"

## 4. Register Summary

Address	Name	Bit 7	Bit 6	Bit 5	Bit 4	Bit 3	Bit 2	Bit 1	Bit 0
(0xFF)	Reserved	–	–	–	–	–	–	–	–
(0xFE)	Reserved	–	–	–	–	–	–	–	–
(0xFD)	Reserved	–	–	–	–	–	–	–	–
(0xFC)	Reserved	–	–	–	–	–	–	–	–
(0xFB)	Reserved	–	–	–	–	–	–	–	–
(0xFA)	CANMSG	MSG 7	MSG 6	MSG 5	MSG 4	MSG 3	MSG 2	MSG 1	MSG 0
(0xF9)	CANSTMPH	TIMSTM15	TIMSTM14	TIMSTM13	TIMSTM12	TIMSTM11	TIMSTM10	TIMSTM9	TIMSTM8
(0xF8)	CANSTMPL	TIMSTM7	TIMSTM6	TIMSTM5	TIMSTM4	TIMSTM3	TIMSTM2	TIMSTM1	TIMSTM0
(0xF7)	CANIDM1	IDMSK28	IDMSK27	IDMSK26	IDMSK25	IDMSK24	IDMSK23	IDMSK22	IDMSK21
(0xF6)	CANIDM2	IDMSK20	IDMSK19	IDMSK18	IDMSK17	IDMSK16	IDMSK15	IDMSK14	IDMSK13
(0xF5)	CANIDM3	IDMSK12	IDMSK11	IDMSK10	IDMSK9	IDMSK8	IDMSK7	IDMSK6	IDMSK5
(0xF4)	CANIDM4	IDMSK4	IDMSK3	IDMSK2	IDMSK1	IDMSK0	RTRMSK	–	IDEMSK
(0xF3)	CANIDT1	IDT28	IDT27	IDT26	IDT25	IDT24	IDT23	IDT22	IDT21
(0xF2)	CANIDT2	IDT20	IDT19	IDT18	IDT17	IDT16	IDT15	IDT14	IDT13
(0xF1)	CANIDT3	IDT12	IDT11	IDT10	IDT9	IDT8	IDT7	IDT6	IDT5
(0xF0)	CANIDT4	IDT4	IDT3	IDT2	IDT1	IDT0	RTRTAG	RB1TAG	RB0TAG
(0xEF)	CANCDMOB	CONMOB1	CONMOB0	RPLV	IDE	DLC3	DLC2	DLC1	DLC0
(0xEE)	CANSTMOB	DLCW	TXOK	RXOK	BERR	SERR	CERR	FERR	AERR
(0xED)	CANPAGE	MOBNB3	MOBNB2	MOBNB1	MOBNB0	AINC	INDX2	INDX1	INDX0
(0xEC)	CANHPMOB	HPMOB3	HPMOB2	HPMOB1	HPMOB0	CGP3	CGP2	CGP1	CGP0
(0xEB)	CANREC	REC7	REC6	REC5	REC4	REC3	REC2	REC1	REC0
(0xEA)	CANTEC	TEC7	TEC6	TEC5	TEC4	TEC3	TEC2	TEC1	TEC0
(0xE9)	CANTTCH	TIMTTC15	TIMTTC14	TIMTTC13	TIMTTC12	TIMTTC11	TIMTTC10	TIMTTC9	TIMTTC8
(0xE8)	CANTTCL	TIMTTC7	TIMTTC6	TIMTTC5	TIMTTC4	TIMTTC3	TIMTTC2	TIMTTC1	TIMTTC0
(0xE7)	CANTIMH	CANTIM15	CANTIM14	CANTIM13	CANTIM12	CANTIM11	CANTIM10	CANTIM9	CANTIM8
(0xE6)	CANTIML	CANTIM7	CANTIM6	CANTIM5	CANTIM4	CANTIM3	CANTIM2	CANTIM1	CANTIM0
(0xE5)	CANTCON	TPRSC7	TPRSC6	TPRSC5	TPRSC4	TPRSC3	TPRSC2	TPRSC1	TPRSC0
(0xE4)	CANBT3	–	PHS22	PHS21	PHS20	PHS12	PHS11	PHS10	SMP
(0xE3)	CANBT2	–	SJW1	SJW0	–	PRS2	PRS1	PRS0	–
(0xE2)	CANBT1	–	BRP5	BRP4	BRP3	BRP2	BRP1	BRP0	–
(0xE1)	CANSIT1	–	–	–	–	–	–	–	–
(0xE0)	CANSIT2	–	–	SIT5	SIT4	SIT3	SIT2	SIT1	SIT0
(0xDF)	CANIE1	–	–	–	–	–	–	–	–

- Notes:
- For compatibility with future devices, reserved bits should be written to zero if accessed. Reserved I/O memory addresses should never be written.
  - I/O registers within the address range 0x00 - 0x1F are directly bit-accessible using the SBI and CBI instructions. In these registers, the value of single bits can be checked by using the SBIS and SBIC instructions.
  - Some of the status flags are cleared by writing a logical one to them. Note that, unlike most other AVR's, the CBI and SBI instructions will only operate on the specified bit, and can therefore be used on registers containing such status flags. The CBI and SBI instructions work with registers 0x00 to 0x1F only.
  - When using the I/O specific commands IN and OUT, the I/O addresses 0x00 - 0x3F must be used. When addressing I/O Registers as data space using LD and ST instructions, 0x20 must be added to these addresses. The ATmega16/32/64/M1/C1 is a complex microcontroller with more peripheral units than can be supported within the 64 location reserved in Opcode for the IN and OUT instructions. For the Extended I/O space from 0x60 - 0xFF in SRAM, only the ST/STS/STD and LD/LDS/LDD instructions can be used.
  - These registers are only available on ATmega32/64M1. For other products described in this datasheet, these locations are reserved.

## 4. Register Summary (Continued)

Address	Name	Bit 7	Bit 6	Bit 5	Bit 4	Bit 3	Bit 2	Bit 1	Bit 0
(0xDE)	CANIE2	–	–	IEMOB5	IEMOB4	IEMOB3	IEMOB2	IEMOB1	IEMOB0
(0xDD)	CANEN1	–	–	–	–	–	–	–	–
(0xDC)	CANEN2	–	–	ENMOB5	ENMOB4	ENMOB3	ENMOB2	ENMOB1	ENMOB0
(0xDB)	CANGIE	ENIT	ENBOFF	ENRX	ENTX	ENERR	ENBX	ENERG	ENOVRT
(0xDA)	CANGIT	CANIT	BOFFIT	OVRTIM	BXOK	SERG	CERG	FERG	AERG
(0xD9)	CANGSTA	–	OVRG	–	TXBSY	RXBSY	ENFG	BOFF	ERRP
(0xD8)	CANGCON	ABRQ	OVRQ	TTC	SYNTTC	LISTEN	TEST	ENA/STB	SWRES
(0xD7)	Reserved	–	–	–	–	–	–	–	–
(0xD6)	Reserved	–	–	–	–	–	–	–	–
(0xD5)	Reserved	–	–	–	–	–	–	–	–
(0xD4)	Reserved	–	–	–	–	–	–	–	–
(0xD3)	Reserved	–	–	–	–	–	–	–	–
(0xD2)	LINDAT	LDATA7	LDATA6	LDATA5	LDATA4	LDATA3	LDATA2	LDATA1	LDATA0
(0xD1)	LINSEL	–	–	–	–	/LAINC	LINDX2	LINDX1	LINDX0
(0xD0)	LINIDR	LP1	LP0	LID5 / LDL1	LID4 / LDL0	LID3	LID2	LID1	LID0
(0xCF)	LINDLR	LTXDL3	LTXDL2	LTXDL1	LTXDL0	LRXDL3	LRXDL2	LRXDL1	LRXDL0
(0xCE)	LINBRRH	–	–	–	–	LDIV11	LDIV10	LDIV9	LDIV8
(0xCD)	LINBRRL	LDIV7	LDIV6	LDIV5	LDIV4	LDIV3	LDIV2	LDIV1	LDIV0
(0xCC)	LINBTR	LDISR	–	LBT5	LBT4	LBT3	LBT2	LBT1	LBT0
(0xCB)	LINERR	LABORT	LTOERR	LOVERR	LFERR	LSERR	LPERR	LCERR	LBERR
(0xCA)	LINENIR	–	–	–	–	LENERR	LENIDOK	LENTXOK	LENRXOK
(0xC9)	LINSIR	LIDST2	LIDST1	LIDST0	LBUSY	LERR	LIDOK	LTXOK	LRXOK
(0xC8)	LINCR	LSWRES	LIN13	LCONF1	LCONF0	LENA	LCMD2	LCMD1	LCMD0
(0xC7)	Reserved	–	–	–	–	–	–	–	–
(0xC6)	Reserved	–	–	–	–	–	–	–	–
(0xC5)	Reserved	–	–	–	–	–	–	–	–
(0xC4)	Reserved	–	–	–	–	–	–	–	–
(0xC3)	Reserved	–	–	–	–	–	–	–	–
(0xC2)	Reserved	–	–	–	–	–	–	–	–
(0xC1)	Reserved	–	–	–	–	–	–	–	–
(0xC0)	Reserved	–	–	–	–	–	–	–	–
(0xBF)	Reserved	–	–	–	–	–	–	–	–
(0xBE)	Reserved	–	–	–	–	–	–	–	–

- Notes:
- For compatibility with future devices, reserved bits should be written to zero if accessed. Reserved I/O memory addresses should never be written.
  - I/O registers within the address range 0x00 - 0x1F are directly bit-accessible using the SBI and CBI instructions. In these registers, the value of single bits can be checked by using the SBIS and SBIC instructions.
  - Some of the status flags are cleared by writing a logical one to them. Note that, unlike most other AVR's, the CBI and SBI instructions will only operate on the specified bit, and can therefore be used on registers containing such status flags. The CBI and SBI instructions work with registers 0x00 to 0x1F only.
  - When using the I/O specific commands IN and OUT, the I/O addresses 0x00 - 0x3F must be used. When addressing I/O Registers as data space using LD and ST instructions, 0x20 must be added to these addresses. The ATmega16/32/64/M1/C1 is a complex microcontroller with more peripheral units than can be supported within the 64 location reserved in Opcode for the IN and OUT instructions. For the Extended I/O space from 0x60 - 0xFF in SRAM, only the ST/STS/STD and LD/LDS/LDD instructions can be used.
  - These registers are only available on ATmega32/64M1. For other products described in this datasheet, these locations are reserved.



## 4. Register Summary (Continued)

Address	Name	Bit 7	Bit 6	Bit 5	Bit 4	Bit 3	Bit 2	Bit 1	Bit 0
(0xBD)	Reserved	–	–	–	–	–	–	–	–
(0xBC) <sup>(5)</sup>	PIFR	–	–	–	–	PEV2	PEV1	PEV0	PEOP
(0xBB) <sup>(5)</sup>	PIM	–	–	–	–	PEVE2	PEVE1	PEVE0	PEOPE
(0xBA) <sup>(5)</sup>	PMIC2	POVEN2	PISEL2	PELEV2	PFLTE2	PAOC2	PRFM22	PRFM21	PRFM20
(0xB9) <sup>(5)</sup>	PMIC1	POVEN1	PISEL1	PELEV1	PFLTE1	PAOC1	PRFM12	PRFM11	PRFM10
(0xB8) <sup>(5)</sup>	PMIC0	POVEN0	PISEL0	PELEV0	PFLTE0	PAOC0	PRFM02	PRFM01	PRFM00
(0xB7) <sup>(5)</sup>	PCTL	PPRE1	PPRE0	PCLKSEL	–	–	–	PCCYC	PRUN
(0xB6) <sup>(5)</sup>	POC	–	–	POEN2B	POEN2A	POEN1B	POEN1A	POEN0B	POEN0A
(0xB5) <sup>(5)</sup>	PCNF	–	–	PULOCK	PMODE	POPB	POPA	–	–
(0xB4) <sup>(5)</sup>	PSYNC	–	–	PSYNC21	PSYNC20	PSYNC11	PSYNC10	PSYNC01	PSYNC00
(0xB3) <sup>(5)</sup>	POCR_RBH	–	–	–	–	POCR_RB11	POCR_RB10	POCR_RB9	POCR_RB8
(0xB2) <sup>(5)</sup>	POCR_RBL	POCR_RB7	POCR_RB6	POCR_RB5	POCR_RB4	POCR_RB3	POCR_RB2	POCR_RB1	POCR_RB0
(0xB1) <sup>(5)</sup>	POCR2SBH	–	–	–	–	POCR2SB11	POCR2SB10	POCR2SB9	POCR2SB8
(0xB0) <sup>(5)</sup>	POCR2SBL	POCR2SB7	POCR2SB6	POCR2SB5	POCR2SB4	POCR2SB3	POCR2SB2	POCR2SB1	POCR2SB0
(0xAF) <sup>(5)</sup>	POCR2RAH	–	–	–	–	POCR2RA11	POCR2RA10	POCR2RA9	POCR2RA8
(0xAE) <sup>(5)</sup>	POCR2RAL	POCR2RA7	POCR2RA6	POCR2RA5	POCR2RA4	POCR2RA3	POCR2RA2	POCR2RA1	POCR2RA0
(0xAD) <sup>(5)</sup>	POCR2SAH	–	–	–	–	POCR2SA11	POCR2SA10	POCR2SA9	POCR2SA8
(0xAC) <sup>(5)</sup>	POCR2SAL	POCR2SA7	POCR2SA6	POCR2SA5	POCR2SA4	POCR2SA3	POCR2SA2	POCR2SA1	POCR2SA0
(0xAB) <sup>(5)</sup>	POCR1SBH	–	–	–	–	POCR1SB11	POCR1SB10	POCR1SB9	POCR1SB8
(0xAA) <sup>(5)</sup>	POCR1SBL	POCR1SB7	POCR1SB6	POCR1SB5	POCR1SB4	POCR1SB3	POCR1SB2	POCR1SB1	POCR1SB0
(0xA9) <sup>(5)</sup>	POCR1RAH	–	–	–	–	POCR1RA11	POCR1RA10	POCR1RA9	POCR1RA8
(0xA8) <sup>(5)</sup>	POCR1RAL	POCR1RA7	POCR1RA6	POCR1RA5	POCR1RA4	POCR1RA3	POCR1RA2	POCR1RA1	POCR1RA0
(0xA7) <sup>(5)</sup>	POCR1SAH	–	–	–	–	POCR1SA11	POCR1SA10	POCR1SA9	POCR1SA8
(0xA6) <sup>(5)</sup>	POCR1SAL	POCR1SA7	POCR1SA6	POCR1SA5	POCR1SA4	POCR1SA3	POCR1SA2	POCR1SA1	POCR1SA0
(0xA5) <sup>(5)</sup>	POCR0SBH	–	–	–	–	POCR0SB11	POCR0SB10	POCR0SB9	POCR0SB8
(0xA4) <sup>(5)</sup>	POCR0SBL	POCR0SB7	POCR0SB6	POCR0SB5	POCR0SB4	POCR0SB3	POCR0SB2	POCR0SB1	POCR0SB0
(0xA3) <sup>(5)</sup>	POCR0RAH	–	–	–	–	POCR0RA11	POCR0RA10	POCR0RA9	POCR0RA8
(0xA2) <sup>(5)</sup>	POCR0RAL	POCR0RA7	POCR0RA6	POCR0RA5	POCR0RA4	POCR0RA3	POCR0RA2	POCR0RA1	POCR0RA0
(0xA1) <sup>(5)</sup>	POCR0SAH	–	–	–	–	POCR0SA11	POCR0SA10	POCR0SA9	POCR0SA8
(0xA0) <sup>(5)</sup>	POCR0SAL	POCR0SA7	POCR0SA6	POCR0SA5	POCR0SA4	POCR0SA3	POCR0SA2	POCR0SA1	POCR0SA0
(0x9F)	Reserved	–	–	–	–	–	–	–	–
(0x9E)	Reserved	–	–	–	–	–	–	–	–
(0x9D)	Reserved	–	–	–	–	–	–	–	–

- Notes:
- For compatibility with future devices, reserved bits should be written to zero if accessed. Reserved I/O memory addresses should never be written.
  - I/O registers within the address range 0x00 - 0x1F are directly bit-accessible using the SBI and CBI instructions. In these registers, the value of single bits can be checked by using the SBIS and SBIC instructions.
  - Some of the status flags are cleared by writing a logical one to them. Note that, unlike most other AVR, the CBI and SBI instructions will only operate on the specified bit, and can therefore be used on registers containing such status flags. The CBI and SBI instructions work with registers 0x00 to 0x1F only.
  - When using the I/O specific commands IN and OUT, the I/O addresses 0x00 - 0x3F must be used. When addressing I/O Registers as data space using LD and ST instructions, 0x20 must be added to these addresses. The ATmega16/32/64/M1/C1 is a complex microcontroller with more peripheral units than can be supported within the 64 location reserved in Opcode for the IN and OUT instructions. For the Extended I/O space from 0x60 - 0xFF in SRAM, only the ST/STS/STD and LD/LDS/LDD instructions can be used.
  - These registers are only available on ATmega32/64M1. For other products described in this datasheet, these locations are reserved.

## 4. Register Summary (Continued)

Address	Name	Bit 7	Bit 6	Bit 5	Bit 4	Bit 3	Bit 2	Bit 1	Bit 0
(0x9C)	Reserved	–	–	–	–	–	–	–	–
(0x9B)	Reserved	–	–	–	–	–	–	–	–
(0x9A)	Reserved	–	–	–	–	–	–	–	–
(0x99)	Reserved	–	–	–	–	–	–	–	–
(0x98)	Reserved	–	–	–	–	–	–	–	–
(0x97)	AC3CON	AC3EN	AC3IE	AC3IS1	AC3IS0	–	AC3M2	AC3M1	AC3M0
(0x96)	AC2CON	AC2EN	AC2IE	AC2IS1	AC2IS0	–	AC2M2	AC2M1	AC2M0
(0x95)	AC1CON	AC1EN	AC1IE	AC1IS1	AC1IS0	AC1ICE	AC1M2	AC1M1	AC1M0
(0x94)	AC0CON	AC0EN	AC0IE	AC0IS1	AC0IS0	ACCKSEL	AC0M2	AC0M1	AC0M0
(0x93)	Reserved	–	–	–	–	–	–	–	–
(0x92)	DACH	- / DAC9	- / DAC8	- / DAC7	- / DAC6	- / DAC5	- / DAC4	DAC9 / DAC3	DAC8 / DAC2
(0x91)	DACL	DAC7 / DAC1	DAC6 / DAC0	DAC5 / -	DAC4 / -	DAC3 / -	DAC2 / -	DAC1 / -	DAC0 /
(0x90)	DACON	DAATE	DATS2	DATS1	DATS0	–	DALA	DAOE	DAEN
(0x8F)	Reserved	–	–	–	–	–	–	–	–
(0x8E)	Reserved	–	–	–	–	–	–	–	–
(0x8D)	Reserved	–	–	–	–	–	–	–	–
(0x8C)	Reserved	–	–	–	–	–	–	–	–
(0x8B)	OCR1BH	OCR1B15	OCR1B14	OCR1B13	OCR1B12	OCR1B11	OCR1B10	OCR1B9	OCR1B8
(0x8A)	OCR1BL	OCR1B7	OCR1B6	OCR1B5	OCR1B4	OCR1B3	OCR1B2	OCR1B1	OCR1B0
(0x89)	OCR1AH	OCR1A15	OCR1A14	OCR1A13	OCR1A12	OCR1A11	OCR1A10	OCR1A9	OCR1A8
(0x88)	OCR1AL	OCR1A7	OCR1A6	OCR1A5	OCR1A4	OCR1A3	OCR1A2	OCR1A1	OCR1A0
(0x87)	ICR1H	ICR115	ICR114	ICR113	ICR112	ICR111	ICR110	ICR19	ICR18
(0x86)	ICR1L	ICR17	ICR16	ICR15	ICR14	ICR13	ICR12	ICR11	ICR10
(0x85)	TCNT1H	TCNT115	TCNT114	TCNT113	TCNT112	TCNT111	TCNT110	TCNT19	TCNT18
(0x84)	TCNT1L	TCNT17	TCNT16	TCNT15	TCNT14	TCNT13	TCNT12	TCNT11	TCNT10
(0x83)	Reserved	–	–	–	–	–	–	–	–
(0x82)	TCCR1C	FOC1A	FOC1B	–	–	–	–	–	–
(0x81)	TCCR1B	ICNC1	ICES1	–	WGM13	WGM12	CS12	CS11	CS10
(0x80)	TCCR1A	COM1A1	COM1A0	COM1B1	COM1B0	–	–	WGM11	WGM10
(0x7F)	DIDR1	–	AMP2PD	ACMP0D	AMP0PD	AMP0ND	ADC10D	ADC9D	ADC8D
(0x7E)	DIDR0	ADC7D	ADC6D	ADC5D	ADC4D	ADC3D	ADC2D	ADC1D	ADC0D
(0x7D)	Reserved	–	–	–	–	–	–	–	–

- Notes:
1. For compatibility with future devices, reserved bits should be written to zero if accessed. Reserved I/O memory addresses should never be written.
  2. I/O registers within the address range 0x00 - 0x1F are directly bit-accessible using the SBI and CBI instructions. In these registers, the value of single bits can be checked by using the SBIS and SBIC instructions.
  3. Some of the status flags are cleared by writing a logical one to them. Note that, unlike most other AVR's, the CBI and SBI instructions will only operate on the specified bit, and can therefore be used on registers containing such status flags. The CBI and SBI instructions work with registers 0x00 to 0x1F only.
  4. When using the I/O specific commands IN and OUT, the I/O addresses 0x00 - 0x3F must be used. When addressing I/O Registers as data space using LD and ST instructions, 0x20 must be added to these addresses. The ATmega16/32/64/M1/C1 is a complex microcontroller with more peripheral units than can be supported within the 64 location reserved in Opcode for the IN and OUT instructions. For the Extended I/O space from 0x60 - 0xFF in SRAM, only the ST/STS/STD and LD/LDS/LDD instructions can be used.
  5. These registers are only available on ATmega32/64M1. For other products described in this datasheet, these locations are reserved.

## 4. Register Summary (Continued)

Address	Name	Bit 7	Bit 6	Bit 5	Bit 4	Bit 3	Bit 2	Bit 1	Bit 0
(0x7C)	ADMUX	REFS1	REFS0	ADLAR	–	MUX3	MUX2	MUX1	MUX0
(0x7B)	ADCSRB	ADHSM	ISRCEN	AREFEN	–	ADTS3	ADTS2	ADTS1	ADTS0
(0x7A)	ADCSRA	ADEN	ADSC	ADATE	ADIF	ADIE	ADPS2	ADPS1	ADPS0
(0x79)	ADCH	- / ADC9	- / ADC8	- / ADC7	- / ADC6	- / ADC5	- / ADC4	ADC9 / ADC3	ADC8 / ADC2
(0x78)	ADCL	ADC7 / ADC1	ADC6 / ADC0	ADC5 / -	ADC4 / -	ADC3 / -	ADC2 / -	ADC1 / -	ADC0 /
(0x77)	AMP2CSR	AMP2EN	AMP2IS	AMP2G1	AMP2G0	AMPCMP2	AMP2TS2	AMP2TS1	AMP2TS0
(0x76)	AMP1CSR	AMP1EN	AMP1IS	AMP1G1	AMP1G0	AMPCMP1	AMP1TS2	AMP1TS1	AMP1TS0
(0x75)	AMP0CSR	AMP0EN	AMP0IS	AMP0G1	AMP0G0	AMPCMP0	AMP0TS2	AMP0TS1	AMP0TS0
(0x74)	Reserved	–	–	–	–	–	–	–	–
(0x73)	Reserved	–	–	–	–	–	–	–	–
(0x72)	Reserved	–	–	–	–	–	–	–	–
(0x71)	Reserved	–	–	–	–	–	–	–	–
(0x70)	Reserved	–	–	–	–	–	–	–	–
(0x6F)	TIMSK1	–	–	ICIE1	–	–	OCIE1B	OCIE1A	TOIE1
(0x6E)	TIMSK0	–	–	–	–	–	OCIE0B	OCIE0A	TOIE0
(0x6D)	PCMSK3	–	–	–	–	–	PCINT26	PCINT25	PCINT24
(0x6C)	PCMSK2	PCINT23	PCINT22	PCINT21	PCINT20	PCINT19	PCINT18	PCINT17	PCINT16
(0x6B)	PCMSK1	PCINT15	PCINT14	PCINT13	PCINT12	PCINT11	PCINT10	PCINT9	PCINT8
(0x6A)	PCMSK0	PCINT7	PCINT6	PCINT5	PCINT4	PCINT3	PCINT2	PCINT1	PCINT0
(0x69)	EICRA	ISC31	ISC30	ISC21	ISC20	ISC11	ISC10	ISC01	ISC00
(0x68)	PCICR	–	–	–	–	PCIE3	PCIE2	PCIE1	PCIE0
(0x67)	Reserved	–	–	–	–	–	–	–	–
(0x66)	OSCCAL	–	CAL6	CAL5	CAL4	CAL3	CAL2	CAL1	CAL0
(0x65)	Reserved	–	–	–	–	–	–	–	–
(0x64)	PRR	–	PRCAN	PRPSC	PRTIM1	PRTIM0	PRSPI	PRLIN	PRADC
(0x63)	Reserved	–	–	–	–	–	–	–	–
(0x62)	Reserved	–	–	–	–	–	–	–	–
(0x61)	CLKPR	CLKPCE	–	–	–	CLKPS3	CLKPS2	CLKPS1	CLKPS0
(0x60)	WDTCR	WDIF	WDIE	WDP3	WDCE	WDE	WDP2	WDP1	WDP0
0x3F (0x5F)	SREG	I	T	H	S	V	N	Z	C
0x3E (0x5E)	SPH	SP15	SP14	SP13	SP12	SP11	SP10	SP9	SP8
0x3D (0x5D)	SPL	SP7	SP6	SP5	SP4	SP3	SP2	SP1	SP0

- Notes:
1. For compatibility with future devices, reserved bits should be written to zero if accessed. Reserved I/O memory addresses should never be written.
  2. I/O registers within the address range 0x00 - 0x1F are directly bit-accessible using the SBI and CBI instructions. In these registers, the value of single bits can be checked by using the SBIS and SBIC instructions.
  3. Some of the status flags are cleared by writing a logical one to them. Note that, unlike most other AVRs, the CBI and SBI instructions will only operate on the specified bit, and can therefore be used on registers containing such status flags. The CBI and SBI instructions work with registers 0x00 to 0x1F only.
  4. When using the I/O specific commands IN and OUT, the I/O addresses 0x00 - 0x3F must be used. When addressing I/O Registers as data space using LD and ST instructions, 0x20 must be added to these addresses. The ATmega16/32/64/M1/C1 is a complex microcontroller with more peripheral units than can be supported within the 64 location reserved in Opcode for the IN and OUT instructions. For the Extended I/O space from 0x60 - 0xFF in SRAM, only the ST/STS/STD and LD/LDS/LDD instructions can be used.
  5. These registers are only available on ATmega32/64M1. For other products described in this datasheet, these locations are reserved.

## 4. Register Summary (Continued)

Address	Name	Bit 7	Bit 6	Bit 5	Bit 4	Bit 3	Bit 2	Bit 1	Bit 0
0x3C (0x5C)	Reserved	–	–	–	–	–	–	–	–
0x3B (0x5B)	Reserved	–	–	–	–	–	–	–	–
0x3A (0x5A)	Reserved	–	–	–	–	–	–	–	–
0x39 (0x59)	Reserved	–	–	–	–	–	–	–	–
0x38 (0x58)	Reserved	–	–	–	–	–	–	–	–
0x37 (0x57)	SPMCSR	SPMIE	RWWSB	SIGRD	RWWSRE	BLBSET	PGWRT	PGERS	SPMEN
0x36 (0x56)	Reserved	–	–	–	–	–	–	–	–
0x35 (0x55)	MCUCR	SPIPS	–	–	PUD	–	–	IVSEL	IVCE
0x34 (0x54)	MCUSR	–	–	–	–	WDRF	BORF	EXTRF	PORF
0x33 (0x53)	SMCR	–	–	–	–	SM2	SM1	SM0	SE
0x32 (0x52)	MSMCR	Monitor Stop Mode Control Register							
0x31 (0x51)	MONDR	Monitor Data Register							
0x30 (0x50)	ACSR	AC3IF	AC2IF	AC1IF	AC0IF	AC3O	AC2O	AC1O	AC0O
0x2F (0x4F)	Reserved	–	–	–	–	–	–	–	–
0x2E (0x4E)	SPDR	SPD7	SPD6	SPD5	SPD4	SPD3	SPD2	SPD1	SPD0
0x2D (0x4D)	SPSR	SPIF	WCOL	–	–	–	–	–	SPI2X
0x2C (0x4C)	SPCR	SPIE	SPE	DORD	MSTR	CPOL	CPHA	SPR1	SPR0
0x2B (0x4B)	Reserved	–	–	–	–	–	–	–	–
0x2A (0x4A)	Reserved	–	–	–	–	–	–	–	–
0x29 (0x49)	PLLCSR	–	–	–	–	–	PLLF	PLLE	PLOCK
0x28 (0x48)	OCR0B	OCR0B7	OCR0B6	OCR0B5	OCR0B4	OCR0B3	OCR0B2	OCR0B1	OCR0B0
0x27 (0x47)	OCR0A	OCR0A7	OCR0A6	OCR0A5	OCR0A4	OCR0A3	OCR0A2	OCR0A1	OCR0A0
0x26 (0x46)	TCNT0	TCNT07	TCNT06	TCNT05	TCNT04	TCNT03	TCNT02	TCNT01	TCNT00
0x25 (0x45)	TCCR0B	FOC0A	FOC0B	–	–	WGM02	CS02	CS01	CS00
0x24 (0x44)	TCCR0A	COM0A1	COM0A0	COM0B1	COM0B0	–	–	WGM01	WGM00
0x23 (0x43)	GTCCR	TSM	ICPSEL1	–	–	–	–	–	PSRSYNC
0x22 (0x42)	EEARH	–	–	–	–	–	–	EEAR9	EEAR8
0x21 (0x41)	EEARL	EEAR7	EEAR6	EEAR5	EEAR4	EEAR3	EEAR2	EEAR1	EEAR0
0x20 (0x40)	EEDR	EEDR7	EEDR6	EEDR5	EEDR4	EEDR3	EEDR2	EEDR1	EEDR0
0x1F (0x3F)	EECR	–	–	–	–	EERIE	EEMWE	EEWE	EERE
0x1E (0x3E)	GPIOR0	GPIOR07	GPIOR06	GPIOR05	GPIOR04	GPIOR03	GPIOR02	GPIOR01	GPIOR00
0x1D (0x3D)	EIMSK	–	–	–	–	INT3	INT2	INT1	INT0
0x1C (0x3C)	EIFR	–	–	–	–	INTF3	INTF2	INTF1	INTF0

- Notes:
- For compatibility with future devices, reserved bits should be written to zero if accessed. Reserved I/O memory addresses should never be written.
  - I/O registers within the address range 0x00 - 0x1F are directly bit-accessible using the SBI and CBI instructions. In these registers, the value of single bits can be checked by using the SBIS and SBIC instructions.
  - Some of the status flags are cleared by writing a logical one to them. Note that, unlike most other AVR's, the CBI and SBI instructions will only operate on the specified bit, and can therefore be used on registers containing such status flags. The CBI and SBI instructions work with registers 0x00 to 0x1F only.
  - When using the I/O specific commands IN and OUT, the I/O addresses 0x00 - 0x3F must be used. When addressing I/O Registers as data space using LD and ST instructions, 0x20 must be added to these addresses. The ATmega16/32/64/M1/C1 is a complex microcontroller with more peripheral units than can be supported within the 64 location reserved in Opcode for the IN and OUT instructions. For the Extended I/O space from 0x60 - 0xFF in SRAM, only the ST/STS/STD and LD/LDS/LDD instructions can be used.
  - These registers are only available on ATmega32/64M1. For other products described in this datasheet, these locations are reserved.

## 4. Register Summary (Continued)

Address	Name	Bit 7	Bit 6	Bit 5	Bit 4	Bit 3	Bit 2	Bit 1	Bit 0
0x1B (0x3B)	PCIFR	–	–	–	–	PCIF3	PCIF2	PCIF1	PCIF0
0x1A (0x3A)	GPIOR2	GPIOR27	GPIOR26	GPIOR25	GPIOR24	GPIOR23	GPIOR22	GPIOR21	GPIOR20
0x19 (0x39)	GPIOR1	GPIOR17	GPIOR16	GPIOR15	GPIOR14	GPIOR13	GPIOR12	GPIOR11	GPIOR10
0x18 (0x38)	Reserved	–	–	–	–	–	–	–	–
0x17 (0x37)	Reserved	–	–	–	–	–	–	–	–
0x16 (0x36)	TIFR1	–	–	ICF1	–	–	OCF1B	OCF1A	TOV1
0x15 (0x35)	TIFR0	–	–	–	–	–	OCF0B	OCF0A	TOV0
0x14 (0x34)	Reserved	–	–	–	–	–	–	–	–
0x13 (0x33)	Reserved	–	–	–	–	–	–	–	–
0x12 (0x32)	Reserved	–	–	–	–	–	–	–	–
0x11 (0x31)	Reserved	–	–	–	–	–	–	–	–
0x10 (0x30)	Reserved	–	–	–	–	–	–	–	–
0x0F (0x2F)	Reserved	–	–	–	–	–	–	–	–
0x0E (0x2E)	PORTE	–	–	–	–	–	PORTE2	PORTE1	PORTE0
0x0D (0x2D)	DDRE	–	–	–	–	–	DDE2	DDE1	DDE0
0x0C (0x2C)	PINE	–	–	–	–	–	PINE2	PINE1	PINE0
0x0B (0x2B)	PORTD	PORTD7	PORTD6	PORTD5	PORTD4	PORTD3	PORTD2	PORTD1	PORTD0
0x0A (0x2A)	DDRD	DDD7	DDD6	DDD5	DDD4	DDD3	DDD2	DDD1	DDD0
0x09 (0x29)	PIND	PIND7	PIND6	PIND5	PIND4	PIND3	PIND2	PIND1	PIND0
0x08 (0x28)	PORTC	PORTC7	PORTC6	PORTC5	PORTC4	PORTC3	PORTC2	PORTC1	PORTC0
0x07 (0x27)	DDRC	DDC7	DDC6	DDC5	DDC4	DDC3	DDC2	DDC1	DDC0
0x06 (0x26)	PINC	PINC7	PINC6	PINC5	PINC4	PINC3	PINC2	PINC1	PINC0
0x05 (0x25)	PORTB	PORTB7	PORTB6	PORTB5	PORTB4	PORTB3	PORTB2	PORTB1	PORTB0
0x04 (0x24)	DDRB	DDB7	DDB6	DDB5	DDB4	DDB3	DDB2	DDB1	DDB0
0x03 (0x23)	PINB	PINB7	PINB6	PINB5	PINB4	PINB3	PINB2	PINB1	PINB0
0x02 (0x22)	Reserved	–	–	–	–	–	–	–	–
0x01 (0x21)	Reserved	–	–	–	–	–	–	–	–
0x00 (0x20)	Reserved	–	–	–	–	–	–	–	–

- Notes:
1. For compatibility with future devices, reserved bits should be written to zero if accessed. Reserved I/O memory addresses should never be written.
  2. I/O registers within the address range 0x00 - 0x1F are directly bit-accessible using the SBI and CBI instructions. In these registers, the value of single bits can be checked by using the SBIS and SBIC instructions.
  3. Some of the status flags are cleared by writing a logical one to them. Note that, unlike most other AVR's, the CBI and SBI instructions will only operate on the specified bit, and can therefore be used on registers containing such status flags. The CBI and SBI instructions work with registers 0x00 to 0x1F only.
  4. When using the I/O specific commands IN and OUT, the I/O addresses 0x00 - 0x3F must be used. When addressing I/O Registers as data space using LD and ST instructions, 0x20 must be added to these addresses. The ATmega16/32/64/M1/C1 is a complex microcontroller with more peripheral units than can be supported within the 64 location reserved in Opcode for the IN and OUT instructions. For the Extended I/O space from 0x60 - 0xFF in SRAM, only the ST/STS/STD and LD/LDS/LDD instructions can be used.
  5. These registers are only available on ATmega32/64M1. For other products described in this datasheet, these locations are reserved.

## 5. Errata

### 5.1 Errata Summary

#### 5.1.1 ATmega16M1/16C1/32M1/32C1 Rev. C (Mask Revision)

- LIN break delimiter
- ADC with PSC2-synchronized
- ADC amplifier measurement is unstable

#### 5.1.2 ATmega16M1/16C1/32M1/32C1 Rev. B (Mask Revision)

- The AMPCMPx bits return 0
- No comparison when amplifier is used as comparator input and ADC input
- CRC calculation of diagnostic frames in LIN 2.x.
- Wrong TSOFFSET manufacturing calibration value
- PD0-PD3 set to outputs and PD4 pulled down following power-on with external reset active.
- LIN Break Delimiter
- ADC with PSC2-synchronized
- ADC amplifier measurement is unstable
- PSC emulation
- PSC OCRxx register update according to PLOCK2 usage
- Read/write instructions of MUXn and REFS1:0

#### 5.1.3 ATmega16M1/16C1/32M1/32C1 Rev. A (Mask Revision)

- Inopportune reset of the CANIDM registers
- The AMPCMPx bits return 0
- No comparison when amplifier is used as comparator input and ADC input
- CRC calculation of diagnostic frames in LIN 2.x
- PD0-PD3 set to outputs and PD4 pulled down following power-on with external reset active
- LIN break delimiter
- ADC with PSC2-synchronized
- ADC amplifier measurement is unstable
- PSC emulation
- Read/write instructions of MUXn and REFS1:0

#### 5.1.4 Errata Description

1. **Inopportune Reset of the CANIDM Registers**

After the reception of a CAN frame in a MOB, the ID mask registers are reset.

**Problem Fix / Workaround**

Before enabling a MOB in reception, re-initialize the ID mask registers - **CANIDM[4..1]**.

2. **The AMPCMPx Bits Return 0**

When they are read the AMPCMPx bits in AMPxCSR registers return 0.

**Problem Fix / Workaround**

If the reading of the AMPCMPx bits is required, store the AMPCMPx value in a variable in memory before writing in the AMPxCSR register and read the variable when necessary.

3. **No Comparison when Amplifier is used as Comparator Input and ADC Input**

When it is selected as ADC input, an amplifier receives no clock signal when the ADC is stopped. In that case, if the amplifier is also used as comparator input, no analog signal is propagated and no comparison is done.

**Problem Fix / Workaround**

Select another ADC channel rather than the working amplified channel.

#### 4. CRC Calculation of Diagnostic Frames in LIN 2.x.

Diagnostic frames of LIN 2.x use “classic checksum” calculation. Unfortunately, the setting of the checksum model is enabled when the HEADER is transmitted/received. Usually, in LIN 2.x the LIN/UART controller is initialized to process “enhanced checksums” and a slave task does not know what kind of frame it will work on before checking the ID.

##### Problem Fix / Workaround

This workaround is to be implemented only in case of transmission/reception of diagnostics frames.

- a. Slave task of master node:  
Before enabling the HEADER, the master must set the appropriate LIN13 bitvalue in LINCR register.
- b. For slaves nodes, the workaround is in 2 parts:
  - Before enabling the RESPONSE, use the following function:

```
void lin_wa_head(void) {
    unsigned char temp;
    temp = LINBTR;
    LINCR = 0x00;          // It is not a RESET !
    LINBTR = (1<<LDISR)|temp;
    LINCR = (1<<LIN13)|(1<<LENA)|(0<<LCMD2)|(0<<LCMD1)|(0<<LCMD0);
    LINDLR = 0x88;       // If it isn't already done
}
- Once the RESPONSE is received or sent (having RxOK or TxOK as well as
LERR), use the following function:
void lin_wa_tail(void) {
    LINCR = 0x00;          // It is not a RESET !
    LINBTR = 0x00;
    LINCR = (0<<LIN13)|(1<<LENA)|(0<<LCMD2)|(0<<LCMD1)|(0<<LCMD0);
}
```

The time-out counter is disabled during the RESPONSE when the workaround is set.

#### 5. Wrong TSOFFSET Manufacturing Calibration value.

Erroneous value of TSOFFSET programmed in signature byte.  
(TSOFFSET was introduced from REVB silicon).

##### Problem Fix / Workaround

To identify RevB with wrong TSOFFSET value, check device signature byte at address 0X3F if value is not 0X42 (Ascii code 'B') then use the following formula.

$TS\_OFFSET(True) = (150 * (1 - TS\_GAIN)) + TS\_OFFSET.$

#### 6. PD0-PD3 Set to Outputs and PD4 Pulled Down following Power-on with Eternal Reset Active.

At power-on with the external reset signal active the four I/O lines PD0-PD3 may be forced into an output state. Normally these lines should be in an input state. PD4 may be pulled down with internal 220kΩ resistor. Following release of the reset line (whatever is the startup time) with the clock running the I/Os PD0-PD4 will adopt their intended input state.

##### Problem Fix / Workaround

None

#### 7. LIN Break Delimiter

In SLAVE MODE, a BREAK field detection error can occur under following conditions. The problem occurs if 2 conditions occur simultaneously:

- a. The DOMINANT part of the BREAK is  $(N+0.5) \times T_{bit}$  long with  $N=13, 14, 15,$
- b. The RECESSIVE part of the BREAK (BREAK DELIMITER) is equal to  $1 \times T_{bit}$ . (see note below)

The BREAK\_high is not detected, and the 2nd bit of the SYNC field is interpreted as the BREAK DELIMITER. The error is detected as a framing error on the first bits of the PID or on subsequent Data or a Checksum error.

**There is no error if BREAK\_high is greater than  $1 \times T_{bit} + 18\%$ . There is no problem in Master mode.**

Note: LIN2.1 Protocol Specification paragraph 2.3.1.1 Break field says: “A break field is always generated by the master task(in the master node) and it shall be at least 13 nominal bit times of dominant value, followed by a break delimiter, as shown in [Figure 5-1](#). **The break delimiter shall be at least one nominal bit time long.**”



**Figure 5-1. The Break Field**

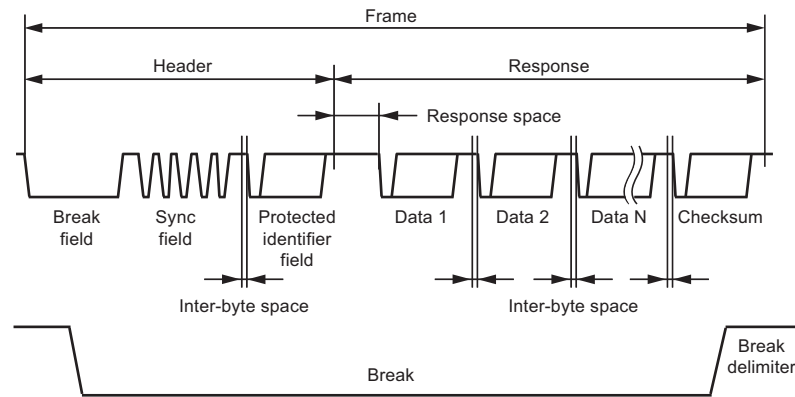

**Workaround**

None

**8. ADC Measurement Reports Abnormal Values with PSC2-synchronized Conversions**

When using ADC in synchronized mode, an unexpected extra Single ended conversion can spuriously re-start. This can occur when the End of conversion and the Trigger event occur at the same time.

**Workaround**

No workaround

**9. ADC Amplifier Measurement is Unstable**

When switching from a single-ended ADC channel to an amplified channel, noise can appear on the next ADC conversion.

**Workaround**

After switching from a single ended to an amplified channel, discard the first ADC conversion.

**10. PSC Emulation**

In emulation mode, TCNTn, OCRnx and ICRn 16-bit registers are accessed via the TEMP register. This can induce an execution error, in step by step mode due to TEMP register corruption.

**Workaround**

No workaround

**11. PSC OCRxx Register Update according to PLOCK2 Usage**

If the PSC is clocked from PLL, and if PLOCK2 bit is changed at the same time as PSC end of cycle occurs, and if OCRxx registers contents have been changed, then the updated OCRxx registers contents are not predictable. The cause is a synchronization issue between two registers in two different clock domains (PLL clock which clocks PSC and CPU clock).

**Workaround**

Enable the PSC end of cycle interrupt.

At the beginning of PSC EOC interrupt vector, change PLOCK value (OCRxx registers can be updated outside the interrupt vector).

This process guarantees that UPDATE and PLOCK actions will not occur at the same moment.

**12. Read / Write Instructions of MUXn and REFS1:0 bits in the ADMUX Register during Analog Conversion**

During Analog conversion, the set or clear instructions of ADMUX channel and reference selection bits will fail. The bits of the temporary buffer will be written in place of the final bits.

**Workaround**

Wait for the end of ADC conversion before any write of new channel or reference selection values in ADMUX.



## 6. Ordering Information

Table 6-1. ATmega16/32/64/M1/C1 Ordering Codes

Memory Size	PSC	Power Supply	Ordering Code	Package	Operation Range
16K	Yes	2.7 to 5.5V	MEGA16M1-15AZ	MA	-40°C to +125°C
16K	Yes	2.7 to 5.5V	MEGA16M1-15MZ	PV	-40°C to +125°C
32K	No	2.7 to 5.5V	MEGA32C1-15AZ	MA	-40°C to +125°C
32K	No	2.7 to 5.5V	MEGA32C1-15MZ	PV	-40°C to +125°C
32K	Yes	2.7 to 5.5V	MEGA32M1-15AZ	MA	-40°C to +125°C
32K	Yes	2.7 to 5.5V	MEGA32M1-15MZ	PV	-40°C to +125°C
64K	No	2.7 to 5.5V	MEGA64C1-15AZ	MA	-40°C to +125°C
64K	No	2.7 to 5.5V	MEGA64C1-15MZ	PV	-40°C to +125°C
64K	Yes	2.7 to 5.5V	MEGA64M1-15AZ	MA	-40°C to +125°C
64K	Yes	2.7 to 5.5V	MEGA64M1-15MZ	PV	-40°C to +125°C

Note: All packages are Pb free, fully LHF

## 7. Package Information

Package Type	
MA	MA, 32 - Lead, 7x7mm body size, 1.0mm body thickness 0.8mm lead pitch, thin profile plastic quad flat package (TQFP)
PV	PV, 32-lead, 7.0x7.0mm body, 0.65mm pitch Quad flat no lead package (QFN)

## 7.1 TQFP32

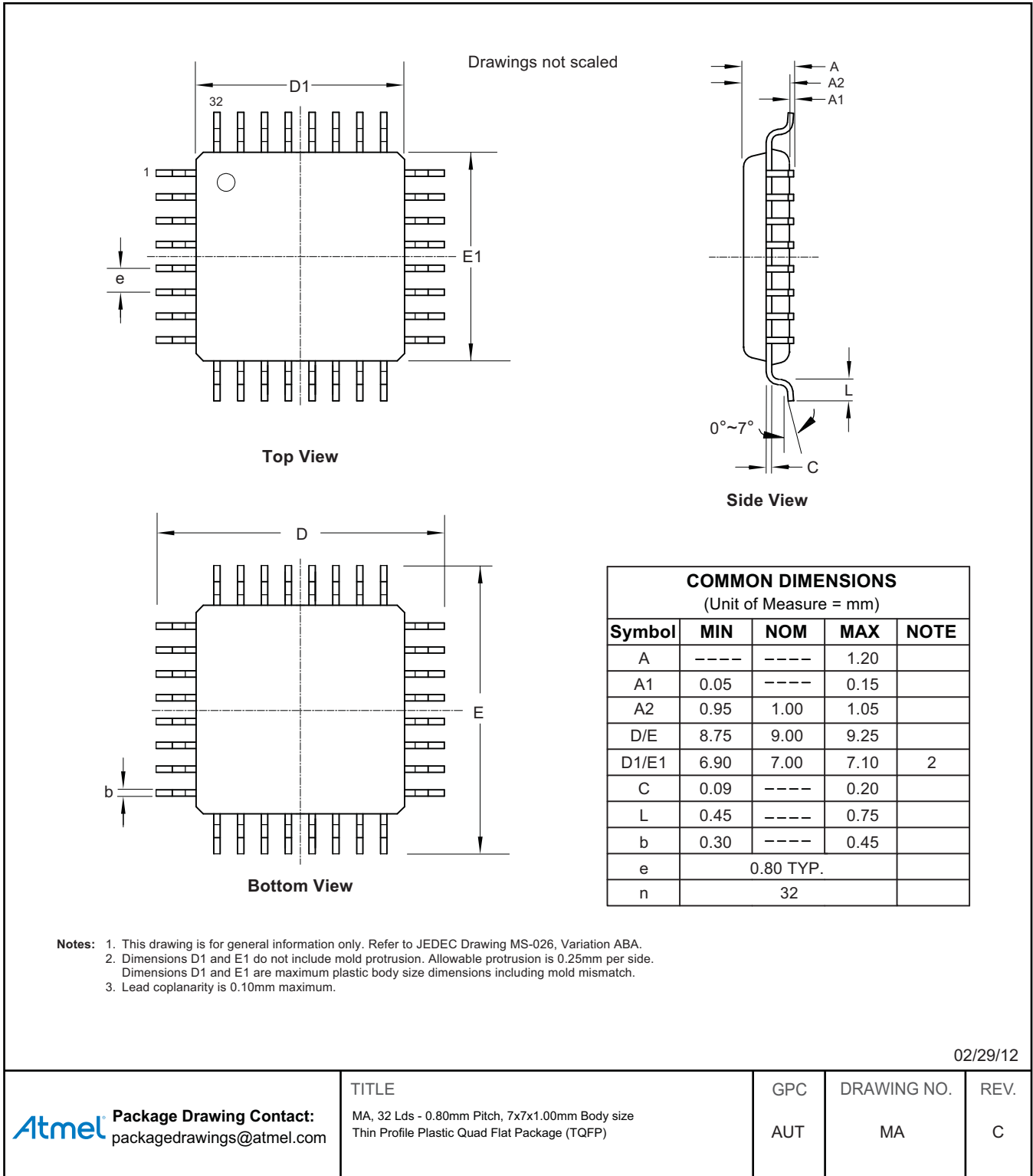

7.2 QFN32

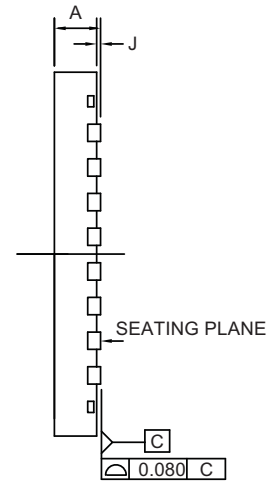
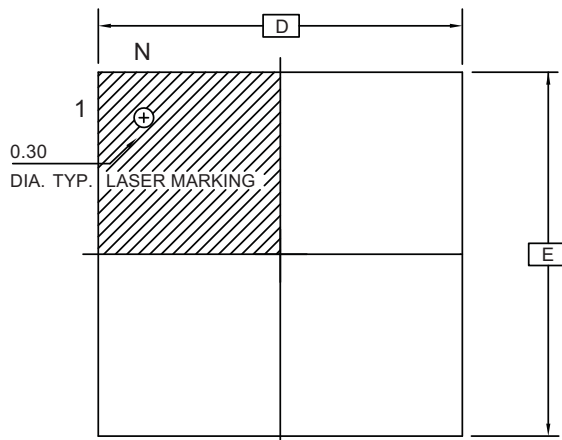

DRAWINGS NOT SCALED

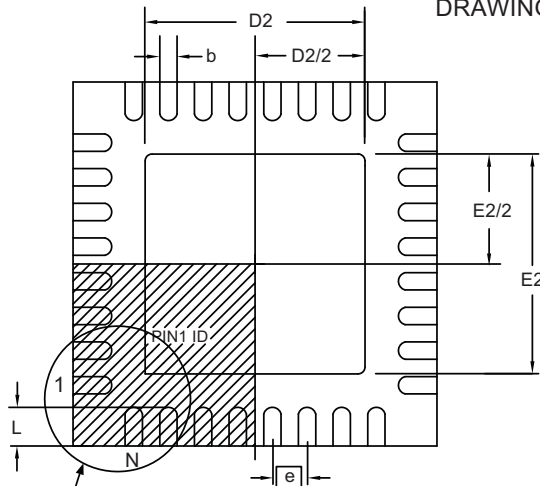

COMMON DIMENSIONS IN MM

SYMBOL	MIN.	NOM.	MAX.	NOTES
A	0.80	0.90	1.00	
J	0.00	0.02	0.05	
D/E	7.00 BSC			
D2/E2	4.40	4.50	4.60	
N	32			
e	0.65 BSC			
L	0.50	0.60	0.70	
b	0.25	0.30	0.37	

See Options A, B, C

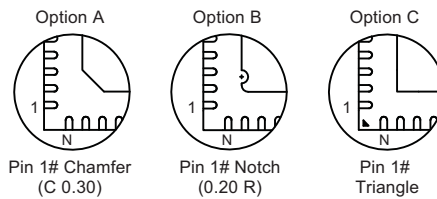

Compliant JEDEC Standard MO-220 Variation VKKC

07/26/07



Package Drawing Contact:  
 packagedrawings@atmel.com

TITLE  
 PV, 32-Lead 7.0x7.0mm Body, 0.65mm Pitch  
 Quad Flat No Lead Package (QFN)

GPC

DRAWING NO.

REV.

PV

F

## 8. Revision History

Please note that the following page numbers referred to in this section refer to the specific revision mentioned, not to this document.

Revision No.	History
7647HS-AVR-01/15	<ul style="list-style-type: none"><li>• Section 5.1.2 “ATmega16M1/16C1/32M1/32C1 Rev. B (Mask Revision)” on page 22 updated</li><li>• Number 11. in Section 5.1.4 “Errata Description” on page 24 added</li></ul>
7647GS-AVR-08/14	<ul style="list-style-type: none"><li>• Section 6 “Ordering Information” on page 25 updated</li></ul>
7647FS-AVR-06/14	<ul style="list-style-type: none"><li>• Put datasheet in the latest template</li></ul>
7647ES-AVR-07/12	<ul style="list-style-type: none"><li>• Section “Features” on page 2 updated</li><li>• Table 1 “ATmega32/64/M1/C1 Product Line-up” on page 2 updated</li></ul>



**Atmel Corporation** 1600 Technology Drive, San Jose, CA 95110 USA T: (+1)(408) 441.0311 F: (+1)(408) 436.4200 | [www.atmel.com](http://www.atmel.com)

© 2015 Atmel Corporation. / Rev.: 7647HS-AVR-01/15

Atmel®, Atmel logo and combinations thereof, Enabling Unlimited Possibilities®, AVR®, and others are registered trademarks or trademarks of Atmel Corporation in U.S. and other countries. Other terms and product names may be trademarks of others.

DISCLAIMER: The information in this document is provided in connection with Atmel products. No license, express or implied, by estoppel or otherwise, to any intellectual property right is granted by this document or in connection with the sale of Atmel products. EXCEPT AS SET FORTH IN THE ATMEL TERMS AND CONDITIONS OF SALES LOCATED ON THE ATMEL WEBSITE, ATMEL ASSUMES NO LIABILITY WHATSOEVER AND DISCLAIMS ANY EXPRESS, IMPLIED OR STATUTORY WARRANTY RELATING TO ITS PRODUCTS INCLUDING, BUT NOT LIMITED TO, THE IMPLIED WARRANTY OF MERCHANTABILITY, FITNESS FOR A PARTICULAR PURPOSE, OR NON-INFRINGEMENT. IN NO EVENT SHALL ATMEL BE LIABLE FOR ANY DIRECT, INDIRECT, CONSEQUENTIAL, PUNITIVE, SPECIAL OR INCIDENTAL DAMAGES (INCLUDING, WITHOUT LIMITATION, DAMAGES FOR LOSS AND PROFITS, BUSINESS INTERRUPTION, OR LOSS OF INFORMATION) ARISING OUT OF THE USE OR INABILITY TO USE THIS DOCUMENT, EVEN IF ATMEL HAS BEEN ADVISED OF THE POSSIBILITY OF SUCH DAMAGES. Atmel makes no representations or warranties with respect to the accuracy or completeness of the contents of this document and reserves the right to make changes to specifications and products descriptions at any time without notice. Atmel does not make any commitment to update the information contained herein. Unless specifically provided otherwise, Atmel products are not suitable for, and shall not be used in, automotive applications. Atmel products are not intended, authorized, or warranted for use as components in applications intended to support or sustain life.

SAFETY-CRITICAL, MILITARY, AND AUTOMOTIVE APPLICATIONS DISCLAIMER: Atmel products are not designed for and will not be used in connection with any applications where the failure of such products would reasonably be expected to result in significant personal injury or death ("Safety-Critical Applications") without an Atmel officer's specific written consent. Safety-Critical Applications include, without limitation, life support devices and systems, equipment or systems for the operation of nuclear facilities and weapons systems. Atmel products are not designed nor intended for use in military or aerospace applications or environments unless specifically designated by Atmel as military-grade. Atmel products are not designed nor intended for use in automotive applications unless specifically designated by Atmel as automotive-grade.

# AMEYA360

## Components Supply Platform

### Authorized Distribution Brand :



### Website :

Welcome to visit [www.ameya360.com](http://www.ameya360.com)

### Contact Us :

#### ➤ Address :

401 Building No.5, JiuGe Business Center, Lane 2301, Yishan Rd  
Minhang District, Shanghai , China

#### ➤ Sales :

Direct +86 (21) 6401-6692

Email [amall@ameya360.com](mailto:amall@ameya360.com)

QQ 800077892

Skype [ameyasales1](#) [ameyasales2](#)

#### ➤ Customer Service :

Email [service@ameya360.com](mailto:service@ameya360.com)

#### ➤ Partnership :

Tel +86 (21) 64016692-8333

Email [mkt@ameya360.com](mailto:mkt@ameya360.com)