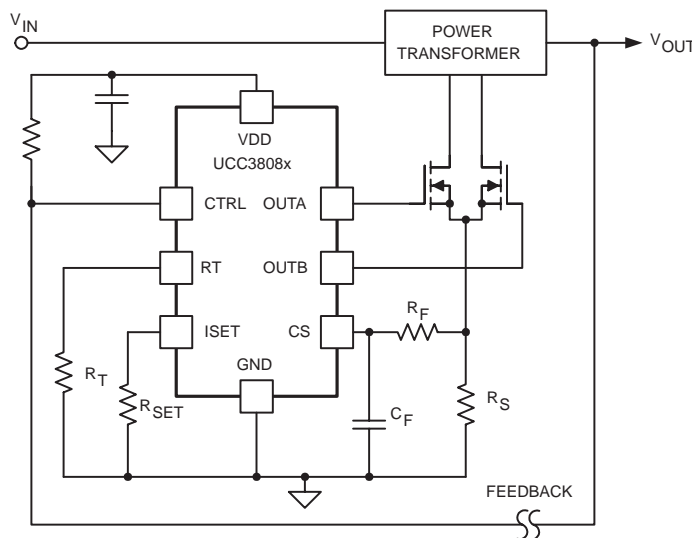


## 8-PIN CURRENT MODE PUSH-PULL PWM CONTROLLERS WITH PROGRAMMABLE SLOPE COMPENSATION

### FEATURES

- Programmable Slope Compensation
- Internal Soft-Start on the UCC38083/4
- Cycle-by-Cycle Current Limiting
- Low Start-Up Current of 120  $\mu$ A and 1.5 mA Typical Run Current
- Single External Component Oscillator Programmable from 50 kHz to 1 MHz
- High-Current Totem-Pole Dual Output Stage Drives Push-Pull Configuration with 1-A Sink and 0.5-A Source Capability
- Current Sense Discharge Transistor to Improve Dynamic Response
- Internally Trimmed Bandgap Reference
- Undervoltage Lockout with Hysteresis

### BASIC APPLICATION



UDG-01080

### APPLICATIONS

- High-Efficiency Switch-Mode Power Supplies
- Telecom dc-to-dc Converters
- Point-of-Load or Point-of-Use Power Modules
- Low-Cost Push-Pull and Half-Bridge Applications

### DESCRIPTION

The UCC38083/4/5/6 is a family of BiCMOS pulse width modulation (PWM) controllers for dc-to-dc or off-line fixed-frequency current-mode switching power supplies. The dual output stages are configured for the push-pull topology. Both outputs switch at half the oscillator frequency using a toggle flip-flop. The dead time between the two outputs is typically 110 ns, limiting each output's duty cycle to less than 50%.

The new UCC3808x family is based on the UCC3808A architecture. The major differences include the addition of a programmable slope compensation ramp to the CS signal and the removal of the error amplifier. The current flowing out of the ISET pin through an external resistor is monitored internally to set the magnitude of the slope compensation function. This device also includes an internal discharge transistor from the CS pin to ground, which is activated at each clock cycle after the pulse is terminated. This discharges any filter capacitance on the CS pin during each cycle and helps minimize filter capacitor values and current sense delay.

The UCC38083 and the UCC38084 devices have a typical soft-start interval time of 3.5 ms while the UCC38085 and the UCC38086 has less than 100  $\mu$ s for applications where internal soft-start is not desired.

The UCC38083 and the UCC38085 devices have the turn-on/off thresholds of 12.5 V / 8.3 V, while the UCC38084 and the UCC38086 has the turn-on/off thresholds of 4.3 V / 4.1 V. Each device is offered in 8-pin TSSOP (PW), 8-pin SOIC (D) and 8-pin PDIP (P) packages.



Please be aware that an important notice concerning availability, standard warranty, and use in critical applications of Texas Instruments semiconductor products and disclaimers thereto appears at the end of this data sheet.

# UCC28083, UCC28084, UCC28085, UCC28086 UCC38083, UCC38084, UCC38085, UCC38086

SLUS488E – SEPTEMBER 2002 – REVISED JULY 2009

## ORDERING INFORMATION

**THERMAL RESISTANCE TABLE**

| PACKAGE      | $\theta_{jc} (^{\circ}\text{C}/\text{W})$ | $\theta_{ja} (^{\circ}\text{C}/\text{W})$ |
|--------------|---|---|
| SOIC-8 (D)   | 42  | 84 to 160 <sup>(1)</sup>                  |
| PDIP-8 (P)   | 50  | 110 <sup>(1)</sup>                        |
| TSSOP-8 (PW) | 32 <sup>(2)</sup>                         | 232 to 257 <sup>(2)</sup>                 |

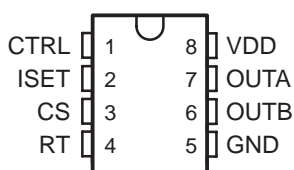
- NOTES: (1) Specified  $\theta_{ja}$  (junction to ambient) is for devices mounted to 5-inch<sup>2</sup> FR4 PC board with one ounce copper where noted. When resistance range is given, lower values are for 5 inch<sup>2</sup> aluminum PC board. Test PWB was 0.062 inch thick and typically used 0.635-mm trace widths for power packages and 1.3-mm trace widths for non-power packages with a 100-mil x 100-mil probe land area at the end of each trace.
- (2). Modeled data. If value range given for  $\theta_{ja}$ , lower value is for 3x3 inch. 1 oz internal copper ground plane, higher value is for 1x1-inch. ground plane. All model data assumes only one trace for each non-fused lead.

**AVAILABLE OPTIONS**

| T <sub>A</sub> | INTERNAL SOFT START | UVLO   |       | PACKAGES   |            |              |
|----------------|---------------------|--------|-------|------------|------------|--------------|
|                |                     | ON     | OFF   | SOIC-8 (D) | PDIP-8 (P) | TSSOP-8 (PW) |
| -40°C to 85°C  | 3.5 ms              | 12.5 V | 8.3 V | UCC28083D  | UCC28083P  | UCC28083PW   |
|                |                     | 4.3 V  | 4.1 V | UCC28084D  | UCC28084P  | UCC28084PW   |
|                | 75 $\mu$ s          | 12.5 V | 8.3 V | UCC28085D  | UCC28085P  | UCC28085PW   |
|                |                     | 4.3 V  | 4.1 V | UCC28086D  | UCC28086P  | UCC28086PW   |
| 0°C to 70°C    | 3.5 ms              | 12.5 V | 8.3 V | UCC38083D  | UCC38083P  | UCC38083PW   |
|                |                     | 4.3 V  | 4.1 V | UCC38084D  | UCC38084P  | UCC38084PW   |
|                | 75 $\mu$ s          | 12.5 V | 8.3 V | UCC38085D  | UCC38085P  | UCC38085PW   |
|                |                     | 4.3 V  | 4.1 V | UCC38086D  | UCC38086P  | UCC38086PW   |

† The D and PW packages are available taped and reeled. Add R suffix to device type, e.g. UCC28083DR (2500 devices per reel) or UCC38083PWR (2000 devices per reel).

**D OR P PACKAGE  
(TOP VIEW)**



**PW PACKAGE  
(TOP VIEW)**



**absolute maximum ratings over operating free-air temperature (unless otherwise noted)†**

|  |   |
|--|---|
| Supply voltage, $V_{DD}$ ( $I_{DD} < 10$ mA)         | 15 V  |
| Supply current, $I_{DD}$                             | 20 mA   |
| Sink current (peak):                                 |   |
| OUTA   | 1.0 A   |
| OUTB   | 1.0 A   |
| Source current (peak):                               |   |
| OUTA   | -0.5 A  |
| OUTB   | -0.5 A  |
| Analog inputs:                                       |   |
| CTRL   | -0.3 V to $V_{DD} + 0.3$ V                    |
| CS   | -0.3 V to $V_{DD} + 0.3$ V, not to exceed 6 V |
| $R_{SET}$ (minimum)                                  | >5 k $\Omega$                                 |
| $R_T$ ( $-100 \mu A < I_{RT} < 100 \mu A$ )          | -0.3 V to 2.0 V                               |
| Power dissipation at $T_A = 25^\circ C$ (P package)  | 1 W   |
| Power dissipation at $T_A = 25^\circ C$ (D package)  | 650 mW  |
| Power dissipation at $T_A = 25^\circ C$ (PW package) | 400 mW  |
| Junction operating temperature, $T_J$                | -55°C to 150°C                                |
| Storage temperature, $T_{stg}$                       | -65°C to 150°C                                |
| Lead temperature (soldering 10 seconds)              | 300°C   |

† Stresses beyond those listed under “absolute maximum ratings” may cause permanent damage to the device. These are stress ratings only, and functional operation of the device at these or any other conditions beyond those indicated under “recommended operating conditions” is not implied. Exposure to absolute-maximum-rated conditions for extended periods may affect device reliability. All voltages are with respect to GND. Currents are positive into, and negative out of the specified terminal.

**electrical characteristics over recommended operating virtual junction temperature range,  $V_{DD} = 10$  V (See Note 1), 1- $\mu F$  capacitor from VDD to GND,  $R_T = 165$  k $\Omega$ ,  $R_F = 1$  k $\Omega$ ,  $C_F = 220$  pF,  $R_{SET} = 50$  k $\Omega$ ,  $T_A = -40^\circ C$  to  $85^\circ C$  for UCC2808x,  $T_A = 0^\circ C$  to  $70^\circ C$  for UCC3808x,  $T_A = T_J$  (unless otherwise noted)**

**overall**

| PARAMETER        | TEST CONDITIONS                         | MIN | TYP | MAX | UNITS   |
|------------------|---|-----|-----|-----|---------|
| Start-up current | $V_{DD} < UVLO$ start threshold voltage |     | 120 | 200 | $\mu A$ |
| Supply current   | CTRL = 0 V, CS = 0 V, See Note 1        |     | 1.5 | 2.5 | mA      |

**undervoltage lockout**

| PARAMETER                             |            | TEST CONDITIONS | MIN  | TYP  | MAX  | UNITS |
|---------------------------------------|------------|-----------------|------|------|------|-------|
| Start threshold voltage               | UCC38083/5 | See Note 1      | 11.5 | 12.5 | 13.5 | V     |
|                                       | UCC38084/6 |                 | 4.1  | 4.3  | 4.5  |       |
| Minimum operating voltage after start | UCC38083/5 |                 | 7.6  | 8.3  | 9.0  |       |
|                                       | UCC38084/6 |                 | 3.9  | 4.1  | 4.3  |       |
| Hysteresis voltage                    | UCC38083/5 |                 | 3.5  | 4.2  | 5.1  |       |
|                                       | UCC38084/6 |                 | 0.1  | 0.2  | 0.3  |       |

**oscillator**

| PARAMETER                        | TEST CONDITIONS    | MIN | TYP | MAX | UNITS |
|----------------------------------|--------------------|-----|-----|-----|-------|
| Frequency                        | $2 \times f(OUTA)$ | 180 | 200 | 220 | kHz   |
| Voltage amplitude                | See Note 2         | 1.4 | 1.5 | 1.6 | V     |
| Oscillator fall time (dead time) |                    |     | 110 | 220 | ns    |
| RT pin voltage                   |                    | 1.2 | 1.5 | 1.6 | V     |

# UCC28083, UCC28084, UCC28085, UCC28086 UCC38083, UCC38084, UCC38085, UCC38086

SLUS488E – SEPTEMBER 2002 – REVISED JULY 2009

electrical characteristics over recommended operating virtual junction temperature range,  $V_{DD} = 10\text{ V}$  (See Note 1),  $1\text{-}\mu\text{F}$  capacitor from VDD to GND,  $R_T = 165\text{ k}\Omega$ ,  $R_F = 1\text{ k}\Omega$ ,  $C_F = 220\text{ pF}$ ,  $R_{SET} = 50\text{ k}\Omega$ ,  $T_A = -40^\circ\text{C}$  to  $85^\circ\text{C}$  for UCC2808x,  $T_A = 0^\circ\text{C}$  to  $70^\circ\text{C}$  for UCC3808x,  $T_A = T_J$  (unless otherwise noted)

## current sense

| PARAMETER                     | TEST CONDITIONS  | MIN  | TYP  | MAX  | UNITS |
|-------------------------------|--|------|------|------|-------|
| Gain                          | See Note 3   | 1.9  | 2.2  | 2.5  | V/V   |
| Maximum input signal voltage  | CTRL = 5 V, See Note 4                                 | 0.47 | 0.52 | 0.57 | V     |
| CS to output delay time       | CTRL = 3.5 V, $0\text{ mV} \leq CS \leq 600\text{ mV}$ |      | 100  | 200  | ns    |
| Source current                |  | -200 |      |      | nA    |
| Sink current                  | CS = 0.5 V, RT = 2.0 V, See Note 5                     | 3    | 7    | 12   | mA    |
| Overcurrent threshold voltage |  | 0.70 | 0.75 | 0.80 | V     |
| CTRL to CS offset voltage     | CS = 0 V, $25^\circ\text{C}$                           | 0.55 | 0.70 | 0.90 | V     |
|                               | CS = 0 V   | 0.37 | 0.70 | 1.10 | V     |

## pulse width modulation

| PARAMETER          | TEST CONDITIONS                      | MIN | TYP | MAX | UNITS |
|--------------------|--------------------------------------|-----|-----|-----|-------|
| Maximum duty cycle | Measured at OUTA or OUTB, See Note 7 | 48% | 49% | 50% |       |
| Minimum duty cycle | CTRL = 0 V                           |     |     | 0%  |       |

## output

| PARAMETER                                | TEST CONDITIONS   | MIN | TYP | MAX | UNITS |
|--|---|-----|-----|-----|-------|
| Low-level output voltage (OUTA or OUTB)  | $I_{OUT} = 100\text{ mA}$                                     |     | 0.5 | 1.0 | V     |
| High-level output voltage (OUTA or OUTB) | $I_{OUT} = -50\text{ mA}$ , $(V_{DD} - V_{OUT})$ , See Note 6 |     | 0.5 | 1.0 |       |
| Rise time                                | $C_{LOAD} = 1\text{ nF}$                                      |     | 25  | 60  | ns    |
| Fall time                                | $C_{LOAD} = 1\text{ nF}$                                      |     | 25  | 60  |       |

## soft-start

| PARAMETER                                      | TEST CONDITIONS   | MIN | TYP | MAX | UNITS         |
|--|---|-----|-----|-----|---------------|
| OUTA/OUTB soft-start interval time, UCC38083/4 | CTRL = 1.8 V, CS = 0 V, Duty cycle from 0 to full, See Note 8 | 1.3 | 3.5 | 8.5 | ms            |
| OUTA/OUTB soft-start interval time, UCC38085/6 | CTRL = 1.8 V, CS = 0 V, Duty cycle from 0 to full, See Note 8 | 30  | 75  | 110 | $\mu\text{s}$ |

## slope compensation

| PARAMETER        | TEST CONDITIONS   | MIN | TYP | MAX | UNITS         |
|------------------|---|-----|-----|-----|---------------|
| $I_{RAMP, peak}$ | $I_{SET, peak} = 30\text{ }\mu\text{A}$ , Full duty cycle | 125 | 150 | 175 | $\mu\text{A}$ |

NOTE 1: For UCCx8083/5, set VDD above the start threshold before setting to 10 V.

NOTE 2: Measured at ISET pin.

NOTE 3: Gain is defined by  $A = \frac{\Delta V_{CTRL}}{\Delta V_{CS}}$ ,  $0 \leq V_{CS} \leq 0.4\text{ V}$ .

NOTE 4: Measured at trip point of latch with CS ramped from 0.4 V to 0.6 V.

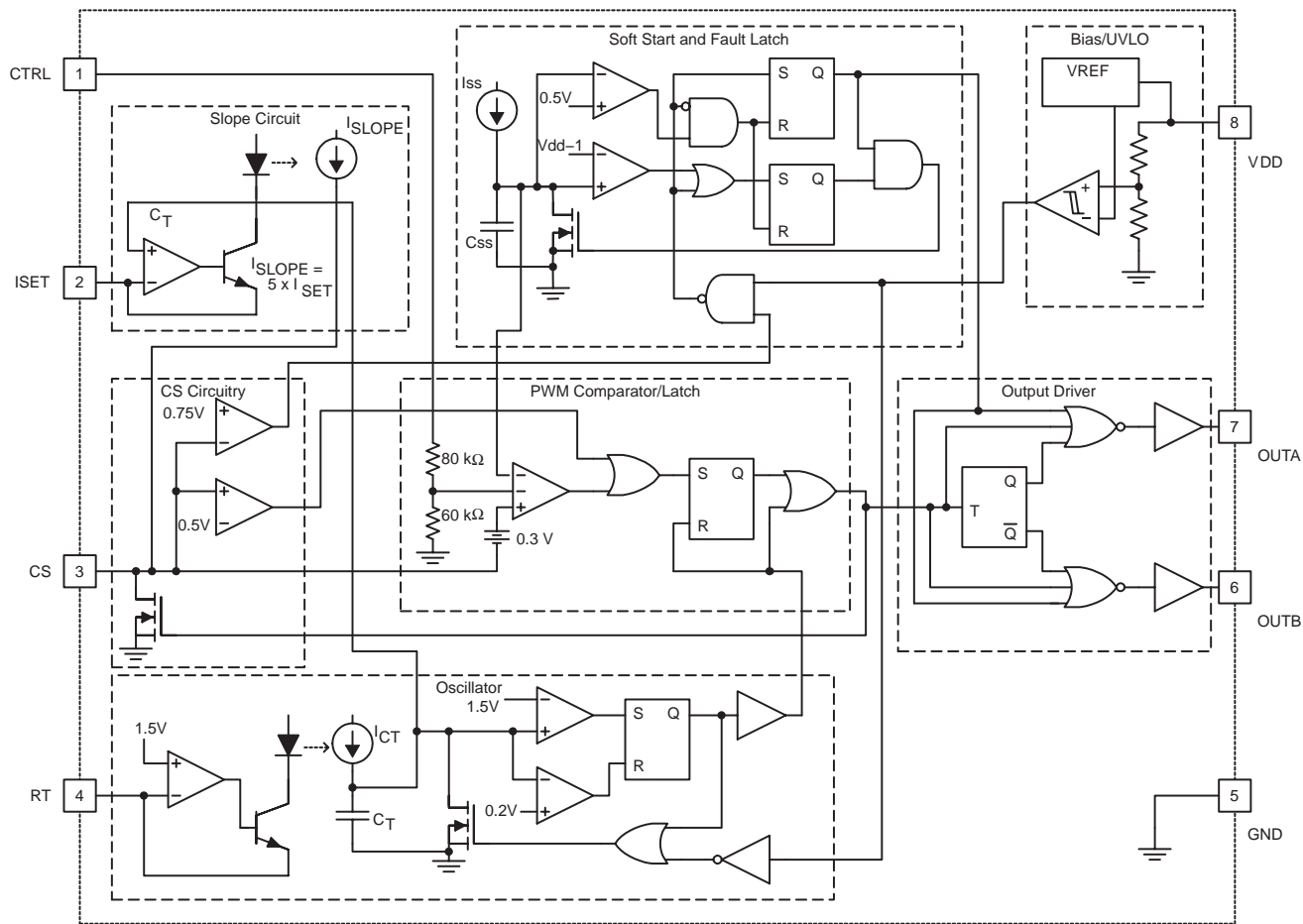
NOTE 5: This internal current sink on the CS pin is designed to discharge and external filter capacitor. It is not intended to be a dc sink path.

NOTE 6: Not 100% production tested. Ensured by design and also by the rise time test.

NOTE 7: For devices in PW package, parameter tested at wafer probe.

NOTE 8: Ensured by design.

**functional block diagram**



UDG-01081

**Terminal Functions**

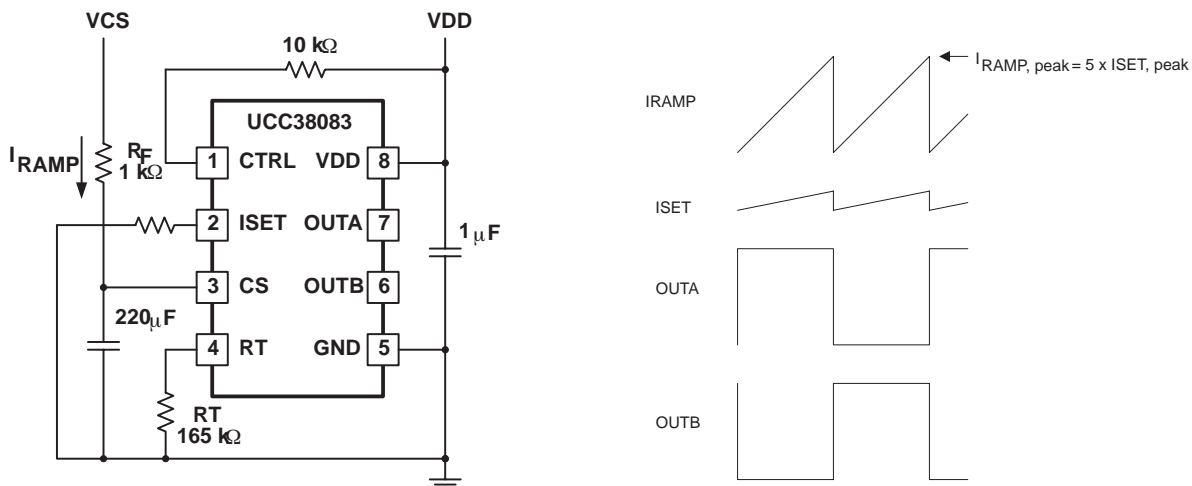
| TERMINAL |                   | I/O | DESCRIPTION  |
|----------|-------------------|-----|--|
| NAME     | PACKAGE<br>D OR P |     |  |
| CS       | 3                 | I   | The current-sense input to the PWM comparator, the cycle-by-cycle peak current comparator, and the overcurrent comparator. The overcurrent comparator is only intended for fault sensing. Exceeding the overcurrent threshold causes a soft-start cycle. An internal MOSFET discharges the current-sense filter capacitor to improve dynamic performance of the power converter. |
| CTRL     | 1                 | I   | Error voltage input to PWM comparator.   |
| GND      | 5                 | -   | Reference ground and power ground for all functions. Due to high currents, and high-frequency operation of the IC, a low-impedance circuit board ground plane is highly recommended.   |
| ISET     | 2                 | I   | Current selection for slope compensation.  |
| OUTA     | 7                 | O   | Alternating high-current output stages.  |
| OUTB     | 6                 | O   |  |
| RT       | 4                 | I   | Programs the oscillator.   |
| VDD      | 8                 | I   | Power input connection.  |

**detailed pin descriptions**

**CTRL:** The error voltage is typically generated by a secondary-side error amplifier and transmitted to the primary-side referenced UCC3808x by means of an opto-coupler. CTRL has an internal divider ratio of 0.45 to maintain a usable range with the minimum  $V_{DD}$  of 4.1 V. The UCC38083/UCC38084 family features a built-in full-cycle soft start while the UCC38085/6 does not.

For the UCC38083/4, soft-start is implemented as a clamp at the input to the PWM comparator. This causes the output pulses to start near 0% duty cycle and increase until the clamp exceeds the CTRL voltage.

**ISET:** Program the slope compensation current ramp by connecting a resistor, RSET, from ISET to ground. The voltage of the ISET pin tracks the 1.5-V internal oscillator ramp, as shown in Figure 1.



**Figure 1. Full Duty Cycle Output**

The compensating current source,  $I_{SLOPE}$ , at the CS pin is proportional to the ISET current, according to the relation:

$$I_{SLOPE} = 5 \times I_{SET} \tag{1}$$

The ramping current due to  $I_{SLOPE}$  develops a voltage across the effective filter impedance that is normally connected from the current sense resistor to the CS input. In order to program a desired compensating slope with a specific peak compensating ramp voltage at the CS pin, use the RSET value in the following equation:

$$RSET = V_{OSC(peak)} \times \left( \frac{5 \times R_F}{RAMP \text{ VOLTAGE HEIGHT}} \right) \tag{2}$$

Where  $V_{OSC(peak)} = 1.5 \text{ V}$

Notice that the PWM Latch drives an internal MOSFET that will discharge an external filtering capacitor on the CS pin. Thus,  $I_{SLOPE}$  will appear to terminate when the PWM comparator or the cycle-by-cycle current limit comparator sets the PWM latch. The actual compensating slope is not affected by premature termination of the switching cycle.

**detailed pin descriptions (continued)**

**OUTA and OUTB:** Alternating high-current output stages. Both stages are capable of driving the gate of a power MOSFET. Each stage is capable of 500-mA peak-source current, and 1-A peak-sink current.

The output stages switch at half the oscillator frequency, in a push-pull configuration. When the voltage on the internal oscillator capacitor is rising, one of the two outputs is high, but during fall time, both outputs are off. This dead time between the two outputs, along with a slower output rise time than fall time, ensures that the two outputs cannot be on at the same time. This dead time is typically 110 ns.

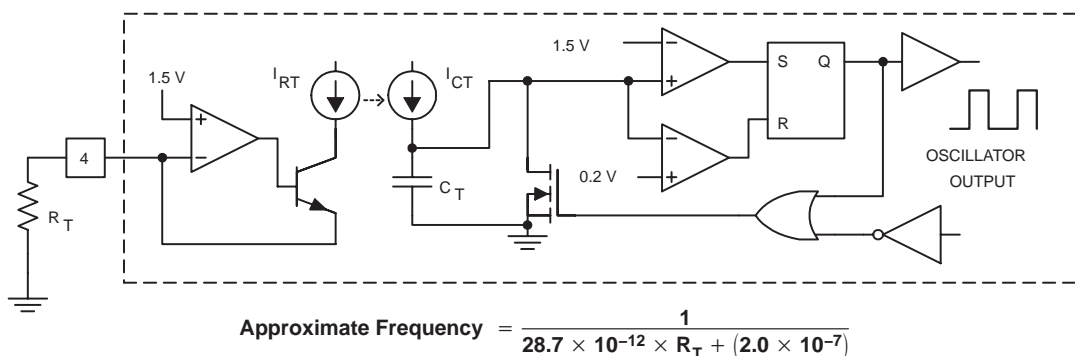
The high-current output drivers consist of MOSFET output devices, which switch from VDD to GND. Each output stage also provides a very low impedance to overshoot and undershoot. This means that in many cases, external Schottky clamp diodes are not required.

**RT:** The oscillator programming pin. The oscillator features an internal timing capacitor. An external resistor,  $R_T$ , sets a current from the RT pin to ground. Due to variations in the internal  $C_T$ , nominal  $V_{RT}$  of 1.5 V can vary from 1.2 V to 1.6 V

Selecting RT as shown programs the oscillator frequency:

$$R_T = \frac{1}{28.7 \times 10^{-12}} \left( \frac{1}{f_{OSC}} - 2.0 \times 10^{-7} \right) \tag{3}$$

where  $f_{OSC}$  is in Hz, resistance in  $\Omega$ . The recommended range of timing resistors is between 25 k $\Omega$  and 698 k $\Omega$ . For best performance, keep the timing resistor lead from the RT pin to GND (pin 5) as short as possible.



UDG-01083

**Figure 2. Block Diagram for Oscillator**

**VDD:** The power input connection for this device. Although quiescent VDD current is very low, total supply current may be higher, depending on OUTA and OUTB current, and the programmed oscillator frequency. Total VDD current is the sum of quiescent VDD current and the average OUT current. Knowing the operating frequency and the MOSFET gate charge ( $Q_G$ ), average OUT current can be calculated from:

$$I_{OUT} = Q_G \times f_{OSC} \tag{4}$$

where f is the oscillator frequency.

To prevent noise problems, bypass VDD to GND with a ceramic capacitor as close to the chip as possible along with an electrolytic capacitor. A 1- $\mu$ F decoupling capacitor is recommended.

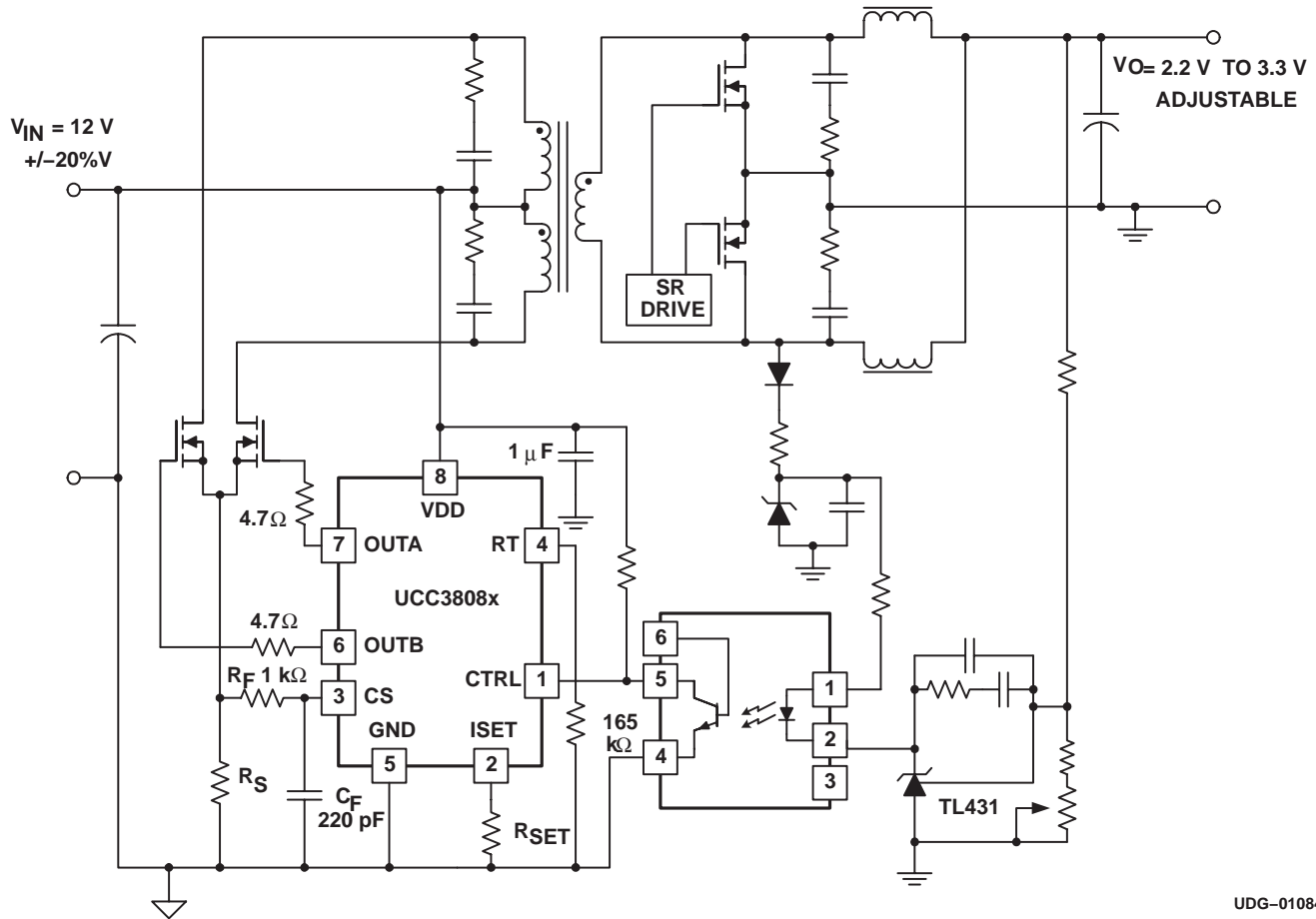
# UCC28083, UCC28084, UCC28085, UCC28086 UCC38083, UCC38084, UCC38085, UCC38086

SLUS488E – SEPTEMBER 2002 – REVISED JULY 2009

## APPLICATION INFORMATION

The following application circuit shows an isolated 12- $V_{IN}$  to 2.5  $V_{OUT}$  push-pull converter with scalable output power (20 W to 200 W). Note that the pinout shown is for SOIC-8 and PDIP-8 packages.

### typical application

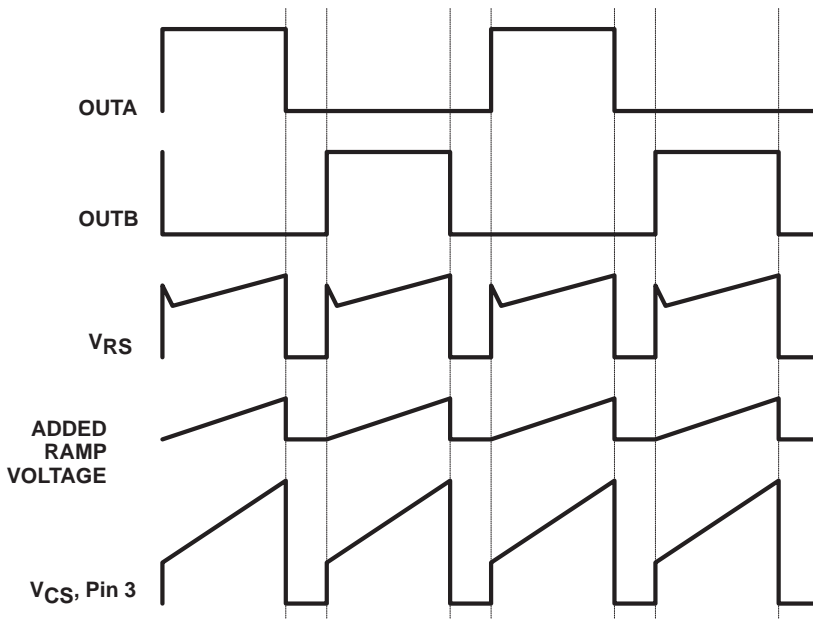


UDG-01084

APPLICATION INFORMATION

operational waveforms

Figure 3 illustrates how the voltage ramp is effectively added to the voltage across the current sense element  $V_{CS}$ , to implement slope compensation.



UDG-01085

Figure 3. Typical Slope Compensation Waveforms at 80% Duty Cycle

In Figure 3, OUTA and OUTB are shown at a duty cycle of 80%, with the associated voltage  $V_{RS}$  across the current sense resistor of the primary push-pull power MOSFETs. The current flowing out of CS generates the ramp voltage across the filter resistor  $R_F$  that is positioned between the power current sense resistor and the CS pin. This voltage is effectively added to  $V_{RS}$  to provide slope compensation at  $V_{CS}$ , pin 3. A capacitor  $C_F$  is also recommended to filter the waveform at CS.

# UCC28083, UCC28084, UCC28085, UCC28086 UCC38083, UCC38084, UCC38085, UCC38086

SLUS488E – SEPTEMBER 2002 – REVISED JULY 2009

## layout considerations

To prevent noise problems, bypass VDD to GND with a ceramic capacitor as close to the chip as possible along with an electrolytic capacitor. A 1- $\mu$ F decoupling capacitor is recommended.

Use a local ground plane near the small signal pins (CTRL, ISET, CS and RT) of the IC for shielding. Connect the local ground plane to the GND pin with a single trace. Do not extend the local ground plane under the power pins (VDD, OUTA, OUTB and GND). Instead, use signal return traces to the GND pin for ground returns on the side of the integrated circuit with the power pins.

For best performance, keep the timing resistor lead from RT pin (pin 4) to GND (pin 5) as short as possible.

## special layout considerations for the TSSOP package

Due to the different pinout and smaller lead pitch of the TSSOP package, special attention must be paid to minimize noise problems. The pinout is different because the device had to be rotated 90° to fit into the smaller TSSOP package.

For example, the two output pins are now on opposite sides of the package. The traces should not run under the package together as they will couple switching noise into analog pins.

Another common problem is when RT and OUTB (pins 6 and 8) are routed together for some distance even though they are not immediate side by side pins. Because of this, when OUTB rises, a voltage spike of upto 400 mV can couple into the RT. This spike causes the internal charge current into CT to be turned off momentarily resulting in lower duty cycle. It is also important that note that the RT pin voltage cannot be stabilized with a capacitor. The RT pin is just a dc voltage to program the internal CT. Instead, keep the OUTB and RT runs short and far from each other and follow the printed wiring board layout suggestions above to fix the problem.

## reference design

A reference design is discussed in *50-W Push-Pull Converter Reference Design Using the UCC38083*, TI Literature Number SLUU135. This design controls a push-pull synchronous rectified topology with input range of 18 V to 35 V (24 nominal) and 3.3-V output at 15 A. The schematic is shown in Figure 5 and the board layout for the reference design is shown in Figure 4. Refer to the document for further details.

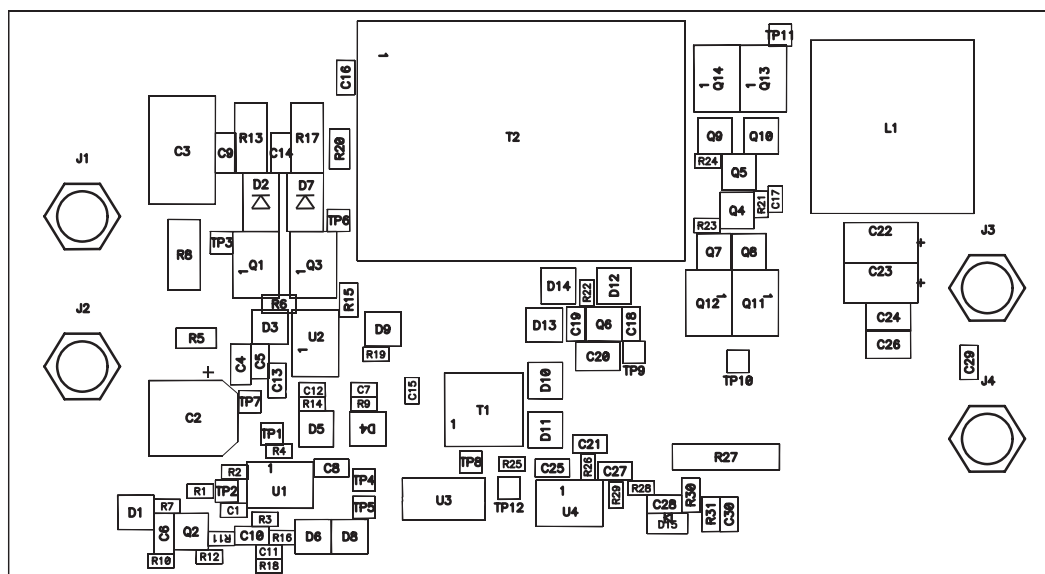


Figure 4. Reference Design Layout

APPLICATION INFORMATION

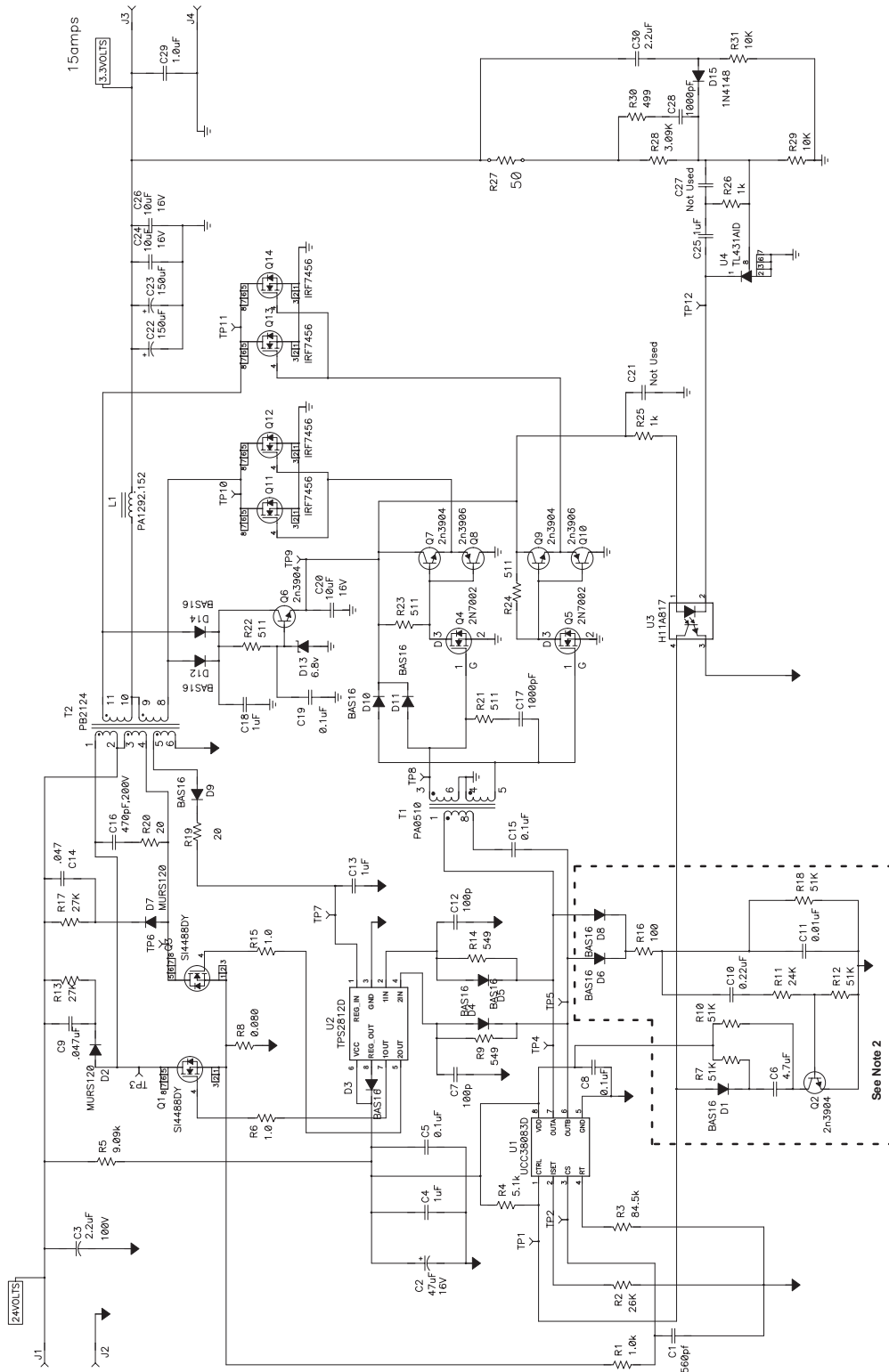


Figure 5. Reference Design Schematic

Note 1. C28, R25, and D12 accelerate the control to the secondary side feedback at start-up and prevent output voltage overshoot.  
 Note 2. Components used for the UCC38085 only.

TYPICAL CHARACTERISTICS

OSCILLATOR FREQUENCY  
 vs  
 TIMING RESISTANCE

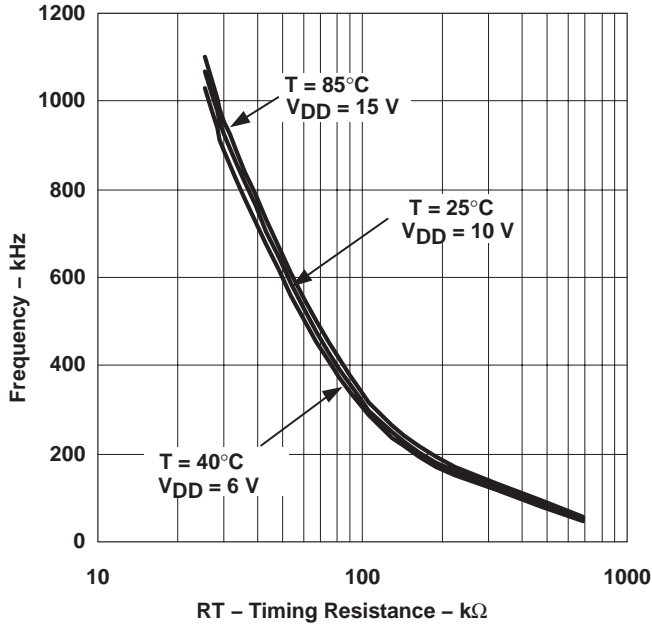


Figure 6

OSCILLATOR FREQUENCY  
 vs  
 TEMPERATURE

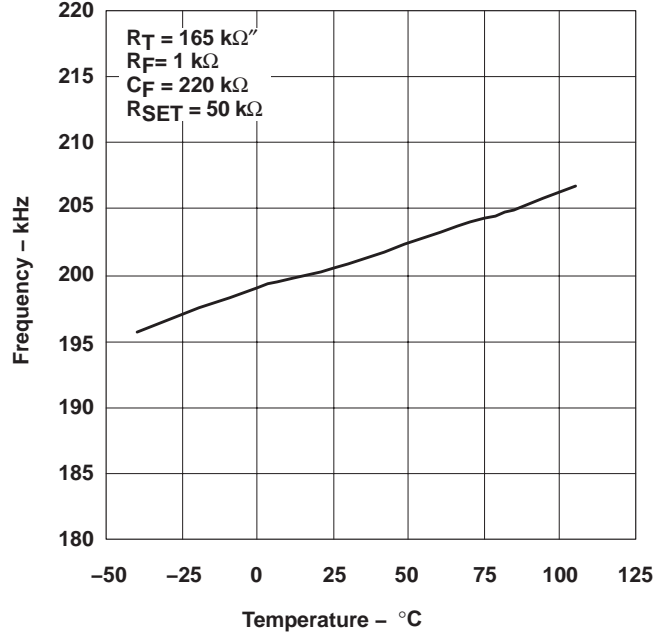


Figure 7

ID<sub>DD</sub>  
 vs  
 OSCILLATOR FREQUENCY, (NO LOAD)

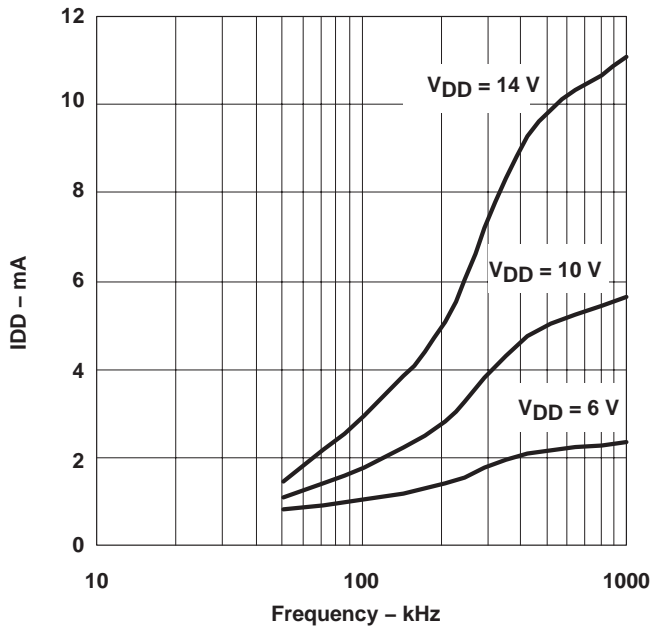


Figure 8

ID<sub>DD</sub>  
 vs  
 OSCILLATOR FREQUENCY, 1 nF LOAD

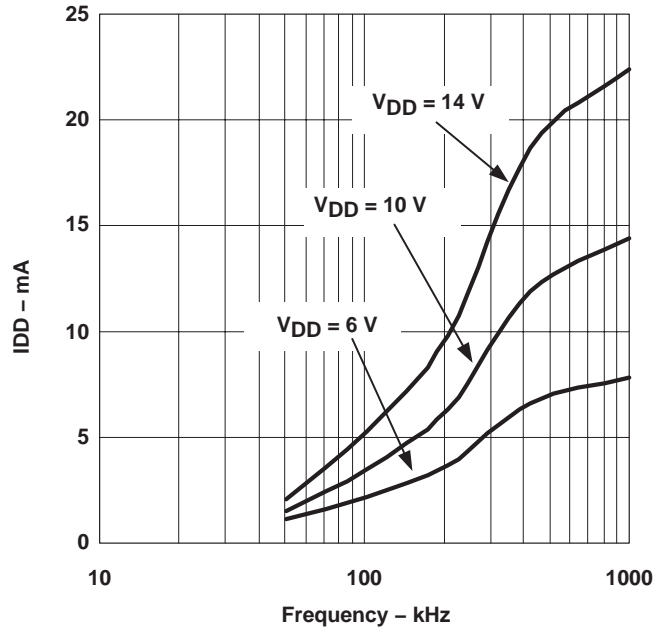


Figure 9

TYPICAL CHARACTERISTICS

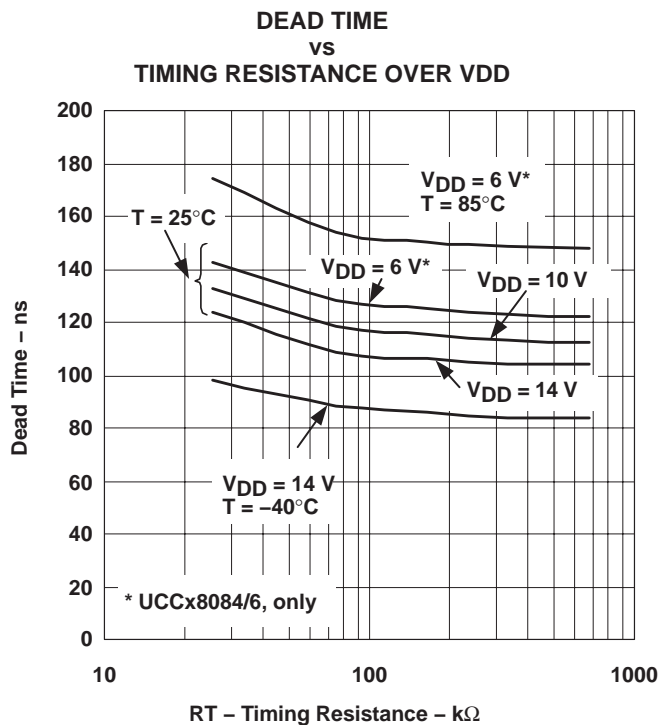


Figure 10

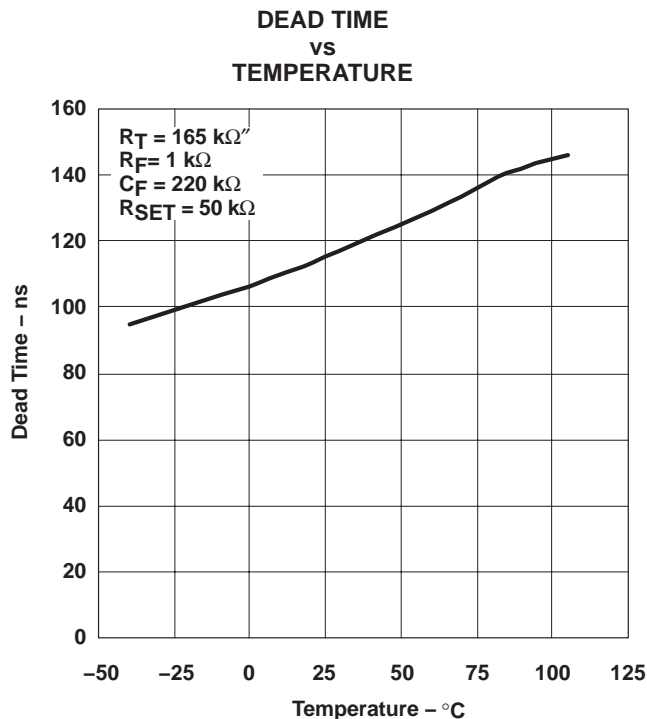


Figure 11

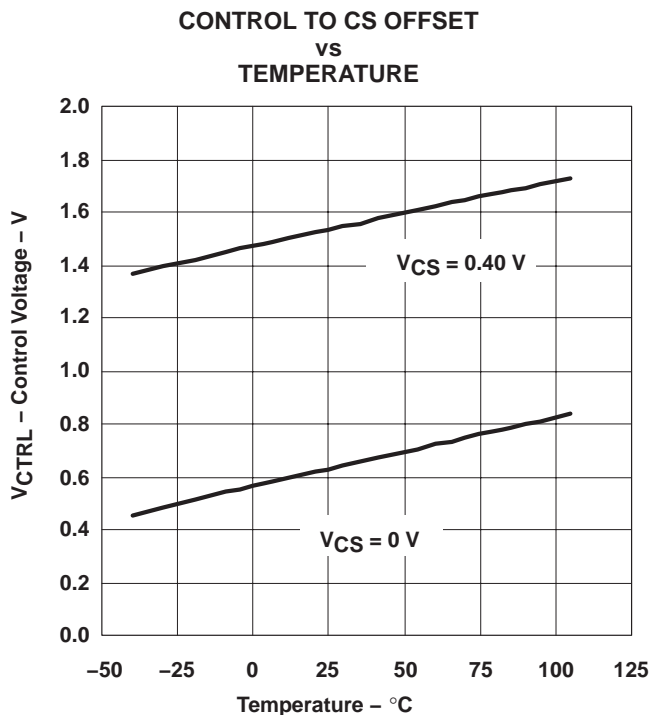


Figure 12

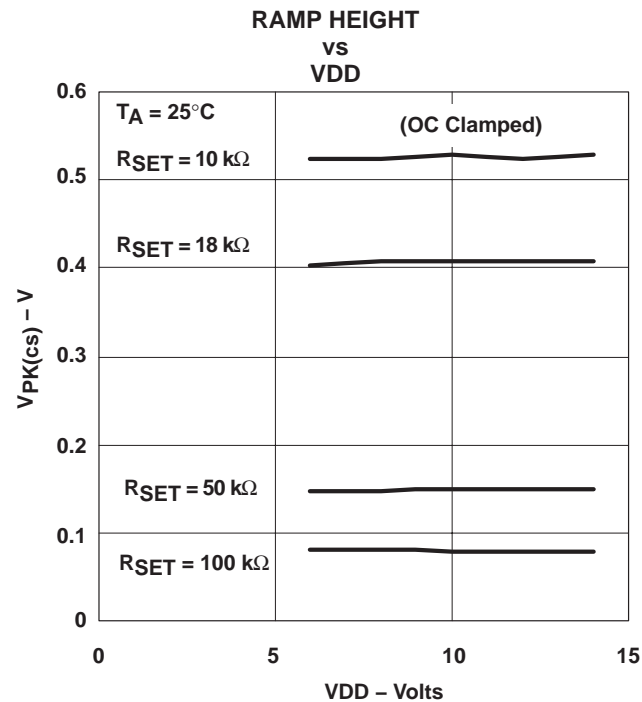
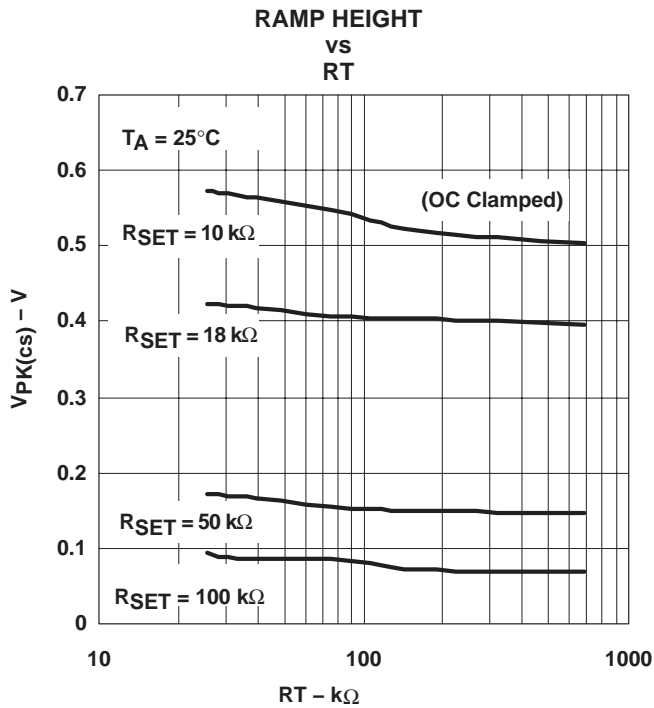
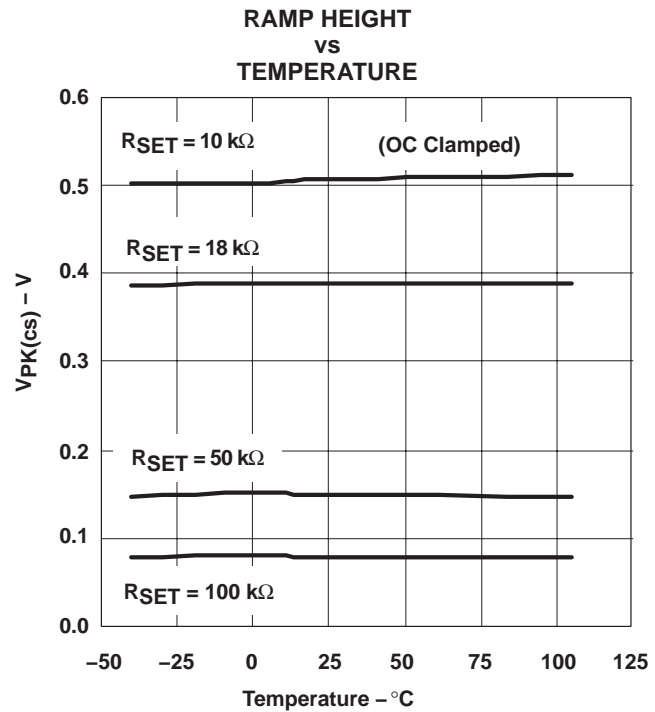


Figure 13

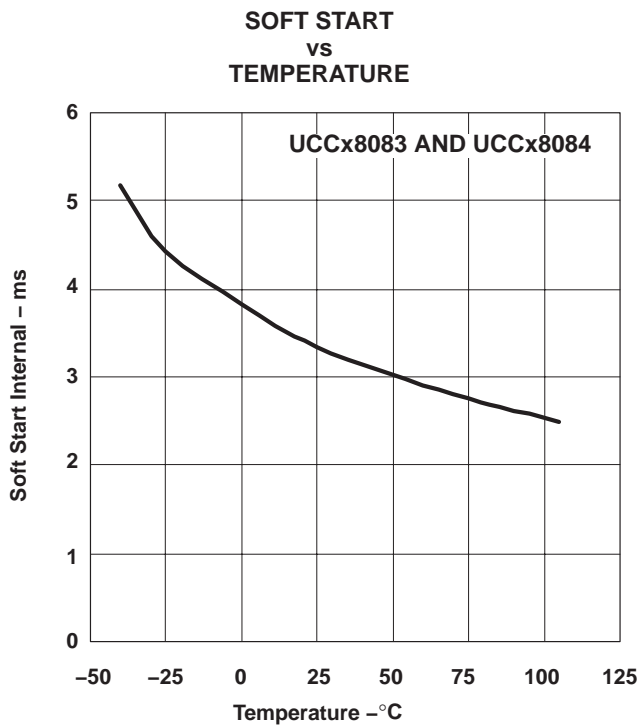
**TYPICAL CHARACTERISTICS**



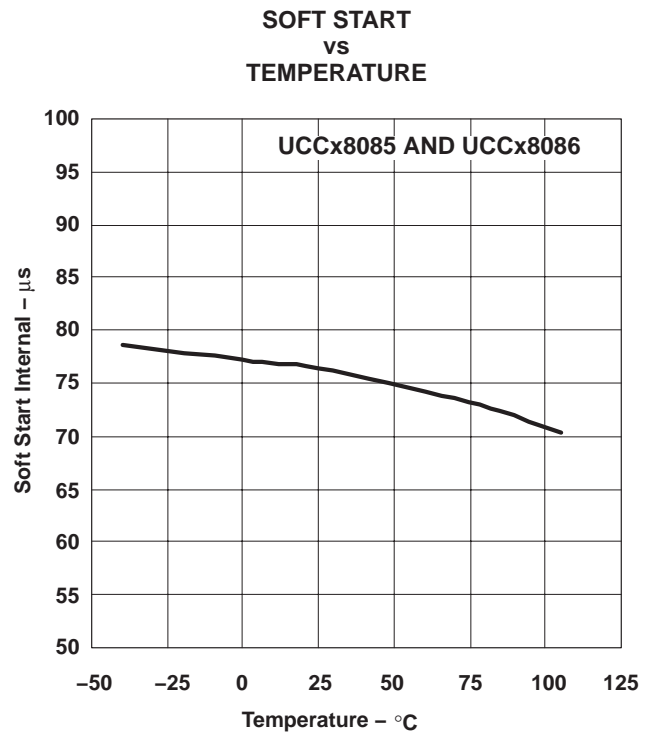
**Figure 14**



**Figure 15**

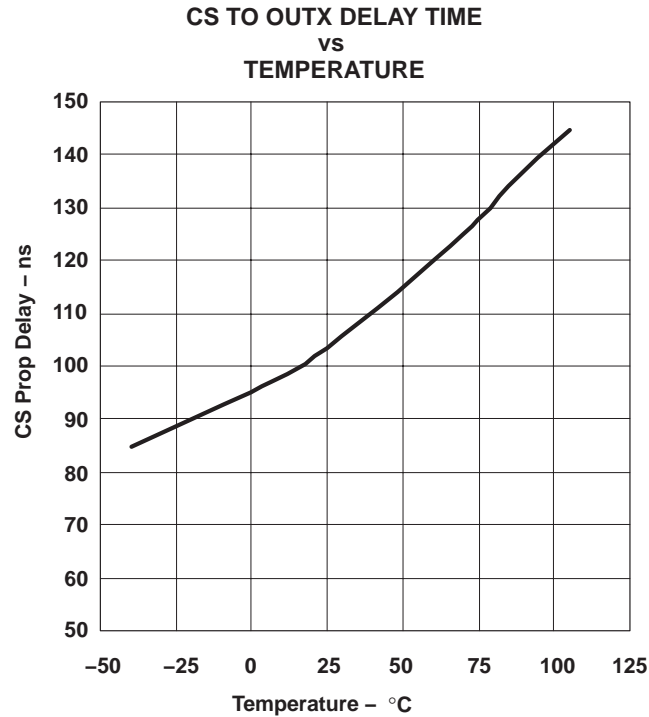


**Figure 16**



**Figure 17**

**TYPICAL CHARACTERISTICS**



**Figure 18**

**RELATED PRODUCTS**

UCC3808, 8-Pin Low Power Current Mode Push-Pull PWM, (SLUS168)

UCC3808A, 8-Pin Low-Power Current-Mode Push-Pull PWM, (SLUS456)

UCC3806, Low Power, Dual Output, Current Mode PWM Controller, (SLUS272)

**Table 1. 8-Pin Push-Pull PWM Controller Family Feature Comparison**

| Part Number | UVLO On | UVLO Off | CS Discharge FET | Error Amplifier | Programmable Slope Compensation | Internal Softstart |
|-------------|---------|----------|------------------|-----------------|---------------------------------|--------------------|
| UCC38083    | 12.5 V  | 8.3 V    | Yes              | No              | Yes                             | Yes                |
| UCC38084    | 4.3 V   | 4.1 V    | Yes              | No              | Yes                             | Yes                |
| UCC38085    | 12.5 V  | 8.3 V    | Yes              | No              | Yes                             | No                 |
| UCC38086    | 4.3 V   | 4.1 V    | Yes              | No              | Yes                             | No                 |
| UCC3808A-1  | 12.5 V  | 8.3 V    | Yes              | Yes             | No                              | Yes                |
| UCC3808A-2  | 4.3 V   | 4.1 V    | Yes              | Yes             | No                              | Yes                |
| UCC3808-1   | 12.5 V  | 8.3 V    | No               | Yes             | No                              | Yes                |
| UCC3808-2   | 4.3 V   | 4.1 V    | No               | Yes             | No                              | Yes                |

**PACKAGING INFORMATION**

| Orderable Device | Status<br>(1) | Package Type | Package<br>Drawing | Pins | Package<br>Qty | Eco Plan<br>(2)            | Lead/Ball Finish<br>(6) | MSL Peak Temp<br>(3) | Op Temp (°C) | Device Marking<br>(4/5) | Samples                 |
|------------------|---------------|--------------|--------------------|------|----------------|----------------------------|-------------------------|----------------------|--------------|-------------------------|-------------------------|
| UCC28083D        | ACTIVE        | SOIC         | D                  | 8    | 75             | Green (RoHS<br>& no Sb/Br) | CU NIPDAU               | Level-1-260C-UNLIM   | -40 to 85    | 28083                   | <a href="#">Samples</a> |
| UCC28083DG4      | ACTIVE        | SOIC         | D                  | 8    | 75             | Green (RoHS<br>& no Sb/Br) | CU NIPDAU               | Level-1-260C-UNLIM   | -40 to 85    | 28083                   | <a href="#">Samples</a> |
| UCC28083DR       | ACTIVE        | SOIC         | D                  | 8    | 2500           | Green (RoHS<br>& no Sb/Br) | CU NIPDAU               | Level-1-260C-UNLIM   | -40 to 85    | 28083                   | <a href="#">Samples</a> |
| UCC28083DRG4     | ACTIVE        | SOIC         | D                  | 8    | 2500           | Green (RoHS<br>& no Sb/Br) | CU NIPDAU               | Level-1-260C-UNLIM   | -40 to 85    | 28083                   | <a href="#">Samples</a> |
| UCC28083P        | ACTIVE        | PDIP         | P                  | 8    | 50             | Green (RoHS<br>& no Sb/Br) | CU NIPDAU               | N / A for Pkg Type   | -40 to 85    | UCC28083P               | <a href="#">Samples</a> |
| UCC28083PG4      | ACTIVE        | PDIP         | P                  | 8    | 50             | Green (RoHS<br>& no Sb/Br) | CU NIPDAU               | N / A for Pkg Type   | -40 to 85    | UCC28083P               | <a href="#">Samples</a> |
| UCC28083PW       | ACTIVE        | TSSOP        | PW                 | 8    | 150            | Green (RoHS<br>& no Sb/Br) | CU NIPDAU               | Level-2-260C-1 YEAR  | -40 to 85    | 28083                   | <a href="#">Samples</a> |
| UCC28084D        | ACTIVE        | SOIC         | D                  | 8    | 75             | Green (RoHS<br>& no Sb/Br) | CU NIPDAU               | Level-1-260C-UNLIM   | -40 to 85    | 28084                   | <a href="#">Samples</a> |
| UCC28084DG4      | ACTIVE        | SOIC         | D                  | 8    | 75             | Green (RoHS<br>& no Sb/Br) | CU NIPDAU               | Level-1-260C-UNLIM   | -40 to 85    | 28084                   | <a href="#">Samples</a> |
| UCC28084DR       | ACTIVE        | SOIC         | D                  | 8    | 2500           | Green (RoHS<br>& no Sb/Br) | CU NIPDAU               | Level-1-260C-UNLIM   | -40 to 85    | 28084                   | <a href="#">Samples</a> |
| UCC28084DRG4     | ACTIVE        | SOIC         | D                  | 8    | 2500           | Green (RoHS<br>& no Sb/Br) | CU NIPDAU               | Level-1-260C-UNLIM   | -40 to 85    | 28084                   | <a href="#">Samples</a> |
| UCC28084P        | ACTIVE        | PDIP         | P                  | 8    | 50             | Green (RoHS<br>& no Sb/Br) | CU NIPDAU               | N / A for Pkg Type   | -40 to 85    | UCC28084P               | <a href="#">Samples</a> |
| UCC28084PW       | ACTIVE        | TSSOP        | PW                 | 8    | 150            | Green (RoHS<br>& no Sb/Br) | CU NIPDAU               | Level-2-260C-1 YEAR  | -40 to 85    | 28084                   | <a href="#">Samples</a> |
| UCC28084PWG4     | ACTIVE        | TSSOP        | PW                 | 8    | 150            | Green (RoHS<br>& no Sb/Br) | CU NIPDAU               | Level-2-260C-1 YEAR  | -40 to 85    | 28084                   | <a href="#">Samples</a> |
| UCC28084PWR      | ACTIVE        | TSSOP        | PW                 | 8    | 2000           | Green (RoHS<br>& no Sb/Br) | CU NIPDAU               | Level-2-260C-1 YEAR  | -40 to 85    | 28084                   | <a href="#">Samples</a> |
| UCC28084PWRG4    | ACTIVE        | TSSOP        | PW                 | 8    | 2000           | Green (RoHS<br>& no Sb/Br) | CU NIPDAU               | Level-2-260C-1 YEAR  | -40 to 85    | 28084                   | <a href="#">Samples</a> |
| UCC28085D        | ACTIVE        | SOIC         | D                  | 8    | 75             | Green (RoHS<br>& no Sb/Br) | CU NIPDAU               | Level-1-260C-UNLIM   | -40 to 85    | 28085                   | <a href="#">Samples</a> |

| Orderable Device | Status<br>(1) | Package Type | Package<br>Drawing | Pins | Package<br>Qty | Eco Plan<br>(2)            | Lead/Ball Finish<br>(6) | MSL Peak Temp<br>(3) | Op Temp (°C) | Device Marking<br>(4/5) | Samples                 |
|------------------|---------------|--------------|--------------------|------|----------------|----------------------------|-------------------------|----------------------|--------------|-------------------------|-------------------------|
| UCC28085DG4      | ACTIVE        | SOIC         | D                  | 8    | 75             | Green (RoHS<br>& no Sb/Br) | CU NIPDAU               | Level-1-260C-UNLIM   | -40 to 85    | 28085                   | <a href="#">Samples</a> |
| UCC28085DR       | ACTIVE        | SOIC         | D                  | 8    | 2500           | Green (RoHS<br>& no Sb/Br) | CU NIPDAU               | Level-1-260C-UNLIM   | -40 to 85    | 28085                   | <a href="#">Samples</a> |
| UCC28085P        | ACTIVE        | PDIP         | P                  | 8    | 50             | Green (RoHS<br>& no Sb/Br) | CU NIPDAU               | N / A for Pkg Type   | -40 to 85    | UCC28085P               | <a href="#">Samples</a> |
| UCC28085PW       | ACTIVE        | TSSOP        | PW                 | 8    | 150            | Green (RoHS<br>& no Sb/Br) | CU NIPDAU               | Level-2-260C-1 YEAR  | -40 to 85    | 28085                   | <a href="#">Samples</a> |
| UCC28086D        | ACTIVE        | SOIC         | D                  | 8    | 75             | Green (RoHS<br>& no Sb/Br) | CU NIPDAU               | Level-1-260C-UNLIM   | -40 to 85    | 28086                   | <a href="#">Samples</a> |
| UCC28086DG4      | ACTIVE        | SOIC         | D                  | 8    | 75             | Green (RoHS<br>& no Sb/Br) | CU NIPDAU               | Level-1-260C-UNLIM   | -40 to 85    | 28086                   | <a href="#">Samples</a> |
| UCC28086DR       | ACTIVE        | SOIC         | D                  | 8    | 2500           | Green (RoHS<br>& no Sb/Br) | CU NIPDAU               | Level-1-260C-UNLIM   | -40 to 85    | 28086                   | <a href="#">Samples</a> |
| UCC28086P        | ACTIVE        | PDIP         | P                  | 8    | 50             | Green (RoHS<br>& no Sb/Br) | CU NIPDAU               | N / A for Pkg Type   | -40 to 85    | UCC28086P               | <a href="#">Samples</a> |
| UCC28086PW       | ACTIVE        | TSSOP        | PW                 | 8    | 150            | Green (RoHS<br>& no Sb/Br) | CU NIPDAU               | Level-2-260C-1 YEAR  | -40 to 85    | 28086                   | <a href="#">Samples</a> |
| UCC28086PWR      | ACTIVE        | TSSOP        | PW                 | 8    | 2000           | Green (RoHS<br>& no Sb/Br) | CU NIPDAU               | Level-2-260C-1 YEAR  | -40 to 85    | 28086                   | <a href="#">Samples</a> |
| UCC38083D        | ACTIVE        | SOIC         | D                  | 8    | 75             | Green (RoHS<br>& no Sb/Br) | CU NIPDAU               | Level-1-260C-UNLIM   | 0 to 70      | 38083                   | <a href="#">Samples</a> |
| UCC38083DG4      | ACTIVE        | SOIC         | D                  | 8    | 75             | Green (RoHS<br>& no Sb/Br) | CU NIPDAU               | Level-1-260C-UNLIM   | 0 to 70      | 38083                   | <a href="#">Samples</a> |
| UCC38083DR       | ACTIVE        | SOIC         | D                  | 8    | 2500           | Green (RoHS<br>& no Sb/Br) | CU NIPDAU               | Level-1-260C-UNLIM   | 0 to 70      | 38083                   | <a href="#">Samples</a> |
| UCC38083P        | ACTIVE        | PDIP         | P                  | 8    | 50             | Green (RoHS<br>& no Sb/Br) | CU NIPDAU               | N / A for Pkg Type   | 0 to 70      | UCC38083P               | <a href="#">Samples</a> |
| UCC38084D        | ACTIVE        | SOIC         | D                  | 8    | 75             | Green (RoHS<br>& no Sb/Br) | CU NIPDAU               | Level-1-260C-UNLIM   | 0 to 70      | 38084                   | <a href="#">Samples</a> |
| UCC38084DG4      | ACTIVE        | SOIC         | D                  | 8    | 75             | Green (RoHS<br>& no Sb/Br) | CU NIPDAU               | Level-1-260C-UNLIM   | 0 to 70      | 38084                   | <a href="#">Samples</a> |
| UCC38084DR       | ACTIVE        | SOIC         | D                  | 8    | 2500           | Green (RoHS<br>& no Sb/Br) | CU NIPDAU               | Level-1-260C-UNLIM   | 0 to 70      | 38084                   | <a href="#">Samples</a> |
| UCC38084DRG4     | ACTIVE        | SOIC         | D                  | 8    | 2500           | Green (RoHS<br>& no Sb/Br) | CU NIPDAU               | Level-1-260C-UNLIM   | 0 to 70      | 38084                   | <a href="#">Samples</a> |

| Orderable Device | Status<br>(1) | Package Type | Package Drawing | Pins | Package Qty | Eco Plan<br>(2)         | Lead/Ball Finish<br>(6) | MSL Peak Temp<br>(3) | Op Temp (°C) | Device Marking<br>(4/5) | Samples                 |
|------------------|---------------|--------------|-----------------|------|-------------|-------------------------|-------------------------|----------------------|--------------|-------------------------|-------------------------|
| UCC38084P        | ACTIVE        | PDIP         | P               | 8    | 50          | Green (RoHS & no Sb/Br) | CU NIPDAU               | N / A for Pkg Type   | 0 to 70      | UCC38084P               | <a href="#">Samples</a> |
| UCC38084PG4      | ACTIVE        | PDIP         | P               | 8    | 50          | Green (RoHS & no Sb/Br) | CU NIPDAU               | N / A for Pkg Type   | 0 to 70      | UCC38084P               | <a href="#">Samples</a> |
| UCC38084PW       | ACTIVE        | TSSOP        | PW              | 8    | 150         | Green (RoHS & no Sb/Br) | CU NIPDAU               | Level-2-260C-1 YEAR  | 0 to 70      | 38084                   | <a href="#">Samples</a> |
| UCC38084PWR      | ACTIVE        | TSSOP        | PW              | 8    | 2000        | Green (RoHS & no Sb/Br) | CU NIPDAU               | Level-2-260C-1 YEAR  | 0 to 70      | 38084                   | <a href="#">Samples</a> |
| UCC38084PWRG4    | ACTIVE        | TSSOP        | PW              | 8    | 2000        | Green (RoHS & no Sb/Br) | CU NIPDAU               | Level-2-260C-1 YEAR  | 0 to 70      | 38084                   | <a href="#">Samples</a> |
| UCC38085D        | ACTIVE        | SOIC         | D               | 8    | 75          | Green (RoHS & no Sb/Br) | CU NIPDAU               | Level-1-260C-UNLIM   | 0 to 70      | 38085                   | <a href="#">Samples</a> |
| UCC38085P        | ACTIVE        | PDIP         | P               | 8    | 50          | Green (RoHS & no Sb/Br) | CU NIPDAU               | N / A for Pkg Type   | 0 to 70      | UCC38085P               | <a href="#">Samples</a> |
| UCC38086D        | ACTIVE        | SOIC         | D               | 8    | 75          | Green (RoHS & no Sb/Br) | CU NIPDAU               | Level-1-260C-UNLIM   | 0 to 70      | 38086                   | <a href="#">Samples</a> |
| UCC38086DR       | ACTIVE        | SOIC         | D               | 8    | 2500        | Green (RoHS & no Sb/Br) | CU NIPDAU               | Level-1-260C-UNLIM   | 0 to 70      | 38086                   | <a href="#">Samples</a> |
| UCC38086P        | ACTIVE        | PDIP         | P               | 8    | 50          | Green (RoHS & no Sb/Br) | CU NIPDAU               | N / A for Pkg Type   | 0 to 70      | UCC38086P               | <a href="#">Samples</a> |

(1) The marketing status values are defined as follows:

**ACTIVE:** Product device recommended for new designs.

**LIFEBUY:** TI has announced that the device will be discontinued, and a lifetime-buy period is in effect.

**NRND:** Not recommended for new designs. Device is in production to support existing customers, but TI does not recommend using this part in a new design.

**PREVIEW:** Device has been announced but is not in production. Samples may or may not be available.

**OBSELETE:** TI has discontinued the production of the device.

(2) Eco Plan - The planned eco-friendly classification: Pb-Free (RoHS), Pb-Free (RoHS Exempt), or Green (RoHS & no Sb/Br) - please check <http://www.ti.com/productcontent> for the latest availability information and additional product content details.

**TBD:** The Pb-Free/Green conversion plan has not been defined.

**Pb-Free (RoHS):** TI's terms "Lead-Free" or "Pb-Free" mean semiconductor products that are compatible with the current RoHS requirements for all 6 substances, including the requirement that lead not exceed 0.1% by weight in homogeneous materials. Where designed to be soldered at high temperatures, TI Pb-Free products are suitable for use in specified lead-free processes.

**Pb-Free (RoHS Exempt):** This component has a RoHS exemption for either 1) lead-based flip-chip solder bumps used between the die and package, or 2) lead-based die adhesive used between the die and leadframe. The component is otherwise considered Pb-Free (RoHS compatible) as defined above.

**Green (RoHS & no Sb/Br):** TI defines "Green" to mean Pb-Free (RoHS compatible), and free of Bromine (Br) and Antimony (Sb) based flame retardants (Br or Sb do not exceed 0.1% by weight in homogeneous material)

- (3) MSL, Peak Temp. - The Moisture Sensitivity Level rating according to the JEDEC industry standard classifications, and peak solder temperature.
- (4) There may be additional marking, which relates to the logo, the lot trace code information, or the environmental category on the device.
- (5) Multiple Device Markings will be inside parentheses. Only one Device Marking contained in parentheses and separated by a "-" will appear on a device. If a line is indented then it is a continuation of the previous line and the two combined represent the entire Device Marking for that device.
- (6) Lead/Ball Finish - Orderable Devices may have multiple material finish options. Finish options are separated by a vertical ruled line. Lead/Ball Finish values may wrap to two lines if the finish value exceeds the maximum column width.

**Important Information and Disclaimer:**The information provided on this page represents TI's knowledge and belief as of the date that it is provided. TI bases its knowledge and belief on information provided by third parties, and makes no representation or warranty as to the accuracy of such information. Efforts are underway to better integrate information from third parties. TI has taken and continues to take reasonable steps to provide representative and accurate information but may not have conducted destructive testing or chemical analysis on incoming materials and chemicals. TI and TI suppliers consider certain information to be proprietary, and thus CAS numbers and other limited information may not be available for release.

In no event shall TI's liability arising out of such information exceed the total purchase price of the TI part(s) at issue in this document sold by TI to Customer on an annual basis.

**TAPE AND REEL INFORMATION**

**QUADRANT ASSIGNMENTS FOR PIN 1 ORIENTATION IN TAPE**


\*All dimensions are nominal

| Device      | Package Type | Package Drawing | Pins | SPQ  | Reel Diameter (mm) | Reel Width W1 (mm) | A0 (mm) | B0 (mm) | K0 (mm) | P1 (mm) | W (mm) | Pin1 Quadrant |
|-------------|--------------|-----------------|------|------|--------------------|--------------------|---------|---------|---------|---------|--------|---------------|
| UCC28083DR  | SOIC         | D               | 8    | 2500 | 330.0              | 12.4               | 6.4     | 5.2     | 2.1     | 8.0     | 12.0   | Q1            |
| UCC28084DR  | SOIC         | D               | 8    | 2500 | 330.0              | 12.4               | 6.4     | 5.2     | 2.1     | 8.0     | 12.0   | Q1            |
| UCC28084PWR | TSSOP        | PW              | 8    | 2000 | 330.0              | 12.4               | 7.0     | 3.6     | 1.6     | 8.0     | 12.0   | Q1            |
| UCC28085DR  | SOIC         | D               | 8    | 2500 | 330.0              | 12.4               | 6.4     | 5.2     | 2.1     | 8.0     | 12.0   | Q1            |
| UCC28086DR  | SOIC         | D               | 8    | 2500 | 330.0              | 12.4               | 6.4     | 5.2     | 2.1     | 8.0     | 12.0   | Q1            |
| UCC28086PWR | TSSOP        | PW              | 8    | 2000 | 330.0              | 12.4               | 7.0     | 3.6     | 1.6     | 8.0     | 12.0   | Q1            |
| UCC38083DR  | SOIC         | D               | 8    | 2500 | 330.0              | 12.4               | 6.4     | 5.2     | 2.1     | 8.0     | 12.0   | Q1            |
| UCC38084DR  | SOIC         | D               | 8    | 2500 | 330.0              | 12.4               | 6.4     | 5.2     | 2.1     | 8.0     | 12.0   | Q1            |
| UCC38084PWR | TSSOP        | PW              | 8    | 2000 | 330.0              | 12.4               | 7.0     | 3.6     | 1.6     | 8.0     | 12.0   | Q1            |
| UCC38086DR  | SOIC         | D               | 8    | 2500 | 330.0              | 12.4               | 6.4     | 5.2     | 2.1     | 8.0     | 12.0   | Q1            |

**TAPE AND REEL BOX DIMENSIONS**


\*All dimensions are nominal

| Device      | Package Type | Package Drawing | Pins | SPQ  | Length (mm) | Width (mm) | Height (mm) |
|-------------|--------------|-----------------|------|------|-------------|------------|-------------|
| UCC28083DR  | SOIC         | D               | 8    | 2500 | 340.5       | 338.1      | 20.6        |
| UCC28084DR  | SOIC         | D               | 8    | 2500 | 340.5       | 338.1      | 20.6        |
| UCC28084PWR | TSSOP        | PW              | 8    | 2000 | 367.0       | 367.0      | 35.0        |
| UCC28085DR  | SOIC         | D               | 8    | 2500 | 340.5       | 338.1      | 20.6        |
| UCC28086DR  | SOIC         | D               | 8    | 2500 | 340.5       | 338.1      | 20.6        |
| UCC28086PWR | TSSOP        | PW              | 8    | 2000 | 367.0       | 367.0      | 35.0        |
| UCC38083DR  | SOIC         | D               | 8    | 2500 | 340.5       | 338.1      | 20.6        |
| UCC38084DR  | SOIC         | D               | 8    | 2500 | 340.5       | 338.1      | 20.6        |
| UCC38084PWR | TSSOP        | PW              | 8    | 2000 | 367.0       | 367.0      | 35.0        |
| UCC38086DR  | SOIC         | D               | 8    | 2500 | 340.5       | 338.1      | 20.6        |

P (R-PDIP-T8)

PLASTIC DUAL-IN-LINE PACKAGE



- NOTES:
- A. All linear dimensions are in inches (millimeters).
  - B. This drawing is subject to change without notice.
  - C. Falls within JEDEC MS-001 variation BA.

PW0008A



**PACKAGE OUTLINE**  
**TSSOP - 1.2 mm max height**

SMALL OUTLINE PACKAGE



4221848/A 02/2015

NOTES:

- All linear dimensions are in millimeters. Any dimensions in parenthesis are for reference only. Dimensioning and tolerancing per ASME Y14.5M.
- This drawing is subject to change without notice.
- This dimension does not include mold flash, protrusions, or gate burrs. Mold flash, protrusions, or gate burrs shall not exceed 0.15 mm per side.
- This dimension does not include interlead flash. Interlead flash shall not exceed 0.25 mm per side.
- Reference JEDEC registration MO-153, variation AA.

# EXAMPLE BOARD LAYOUT

PW0008A

TSSOP - 1.2 mm max height

SMALL OUTLINE PACKAGE



LAND PATTERN EXAMPLE  
SCALE:10X



SOLDER MASK DETAILS  
NOT TO SCALE

4221848/A 02/2015

NOTES: (continued)

- 6. Publication IPC-7351 may have alternate designs.
- 7. Solder mask tolerances between and around signal pads can vary based on board fabrication site.

# EXAMPLE STENCIL DESIGN

PW0008A

TSSOP - 1.2 mm max height

SMALL OUTLINE PACKAGE



SOLDER PASTE EXAMPLE  
BASED ON 0.125 mm THICK STENCIL  
SCALE:10X

4221848/A 02/2015

NOTES: (continued)

8. Laser cutting apertures with trapezoidal walls and rounded corners may offer better paste release. IPC-7525 may have alternate design recommendations.
9. Board assembly site may have different recommendations for stencil design.



D (R-PDSO-G8)

PLASTIC SMALL OUTLINE



- NOTES:
- A. All linear dimensions are in millimeters.
  - B. This drawing is subject to change without notice.
  - C. Publication IPC-7351 is recommended for alternate designs.
  - D. Laser cutting apertures with trapezoidal walls and also rounding corners will offer better paste release. Customers should contact their board assembly site for stencil design recommendations. Refer to IPC-7525 for other stencil recommendations.
  - E. Customers should contact their board fabrication site for solder mask tolerances between and around signal pads.

## IMPORTANT NOTICE

Texas Instruments Incorporated and its subsidiaries (TI) reserve the right to make corrections, enhancements, improvements and other changes to its semiconductor products and services per JESD46, latest issue, and to discontinue any product or service per JESD48, latest issue. Buyers should obtain the latest relevant information before placing orders and should verify that such information is current and complete. All semiconductor products (also referred to herein as "components") are sold subject to TI's terms and conditions of sale supplied at the time of order acknowledgment.

TI warrants performance of its components to the specifications applicable at the time of sale, in accordance with the warranty in TI's terms and conditions of sale of semiconductor products. Testing and other quality control techniques are used to the extent TI deems necessary to support this warranty. Except where mandated by applicable law, testing of all parameters of each component is not necessarily performed.

TI assumes no liability for applications assistance or the design of Buyers' products. Buyers are responsible for their products and applications using TI components. To minimize the risks associated with Buyers' products and applications, Buyers should provide adequate design and operating safeguards.

TI does not warrant or represent that any license, either express or implied, is granted under any patent right, copyright, mask work right, or other intellectual property right relating to any combination, machine, or process in which TI components or services are used. Information published by TI regarding third-party products or services does not constitute a license to use such products or services or a warranty or endorsement thereof. Use of such information may require a license from a third party under the patents or other intellectual property of the third party, or a license from TI under the patents or other intellectual property of TI.

Reproduction of significant portions of TI information in TI data books or data sheets is permissible only if reproduction is without alteration and is accompanied by all associated warranties, conditions, limitations, and notices. TI is not responsible or liable for such altered documentation. Information of third parties may be subject to additional restrictions.

Resale of TI components or services with statements different from or beyond the parameters stated by TI for that component or service voids all express and any implied warranties for the associated TI component or service and is an unfair and deceptive business practice. TI is not responsible or liable for any such statements.

Buyer acknowledges and agrees that it is solely responsible for compliance with all legal, regulatory and safety-related requirements concerning its products, and any use of TI components in its applications, notwithstanding any applications-related information or support that may be provided by TI. Buyer represents and agrees that it has all the necessary expertise to create and implement safeguards which anticipate dangerous consequences of failures, monitor failures and their consequences, lessen the likelihood of failures that might cause harm and take appropriate remedial actions. Buyer will fully indemnify TI and its representatives against any damages arising out of the use of any TI components in safety-critical applications.

In some cases, TI components may be promoted specifically to facilitate safety-related applications. With such components, TI's goal is to help enable customers to design and create their own end-product solutions that meet applicable functional safety standards and requirements. Nonetheless, such components are subject to these terms.

No TI components are authorized for use in FDA Class III (or similar life-critical medical equipment) unless authorized officers of the parties have executed a special agreement specifically governing such use.

Only those TI components which TI has specifically designated as military grade or "enhanced plastic" are designed and intended for use in military/aerospace applications or environments. Buyer acknowledges and agrees that any military or aerospace use of TI components which have **not** been so designated is solely at the Buyer's risk, and that Buyer is solely responsible for compliance with all legal and regulatory requirements in connection with such use.

TI has specifically designated certain components as meeting ISO/TS16949 requirements, mainly for automotive use. In any case of use of non-designated products, TI will not be responsible for any failure to meet ISO/TS16949.

### Products

|                              |  |
|------------------------------|--|
| Audio                        | <a href="http://www.ti.com/audio">www.ti.com/audio</a>                               |
| Amplifiers                   | <a href="http://amplifier.ti.com">amplifier.ti.com</a>                               |
| Data Converters              | <a href="http://dataconverter.ti.com">dataconverter.ti.com</a>                       |
| DLP® Products                | <a href="http://www.dlp.com">www.dlp.com</a>   |
| DSP                          | <a href="http://dsp.ti.com">dsp.ti.com</a>   |
| Clocks and Timers            | <a href="http://www.ti.com/clocks">www.ti.com/clocks</a>                             |
| Interface                    | <a href="http://interface.ti.com">interface.ti.com</a>                               |
| Logic                        | <a href="http://logic.ti.com">logic.ti.com</a>                                       |
| Power Mgmt                   | <a href="http://power.ti.com">power.ti.com</a>                                       |
| Microcontrollers             | <a href="http://microcontroller.ti.com">microcontroller.ti.com</a>                   |
| RFID                         | <a href="http://www.ti-rfid.com">www.ti-rfid.com</a>                                 |
| OMAP Applications Processors | <a href="http://www.ti.com/omap">www.ti.com/omap</a>                                 |
| Wireless Connectivity        | <a href="http://www.ti.com/wirelessconnectivity">www.ti.com/wirelessconnectivity</a> |

### Applications

|                               |  |
|-------------------------------|--|
| Automotive and Transportation | <a href="http://www.ti.com/automotive">www.ti.com/automotive</a>                         |
| Communications and Telecom    | <a href="http://www.ti.com/communications">www.ti.com/communications</a>                 |
| Computers and Peripherals     | <a href="http://www.ti.com/computers">www.ti.com/computers</a>                           |
| Consumer Electronics          | <a href="http://www.ti.com/consumer-apps">www.ti.com/consumer-apps</a>                   |
| Energy and Lighting           | <a href="http://www.ti.com/energy">www.ti.com/energy</a>                                 |
| Industrial                    | <a href="http://www.ti.com/industrial">www.ti.com/industrial</a>                         |
| Medical                       | <a href="http://www.ti.com/medical">www.ti.com/medical</a>                               |
| Security                      | <a href="http://www.ti.com/security">www.ti.com/security</a>                             |
| Space, Avionics and Defense   | <a href="http://www.ti.com/space-avionics-defense">www.ti.com/space-avionics-defense</a> |
| Video and Imaging             | <a href="http://www.ti.com/video">www.ti.com/video</a>                                   |

### TI E2E Community

[e2e.ti.com](http://e2e.ti.com)

# AMEYA360

## Components Supply Platform

Authorized Distribution Brand :



Website :

Welcome to visit [www.ameya360.com](http://www.ameya360.com)

Contact Us :

➤ Address :

401 Building No.5, JiuGe Business Center, Lane 2301, Yishan Rd  
Minhang District, Shanghai , China

➤ Sales :

Direct +86 (21) 6401-6692

Email [amall@ameya360.com](mailto:amall@ameya360.com)

QQ 800077892

Skype [ameyasales1](#) [ameyasales2](#)

➤ Customer Service :

Email [service@ameya360.com](mailto:service@ameya360.com)

➤ Partnership :

Tel +86 (21) 64016692-8333

Email [mkt@ameya360.com](mailto:mkt@ameya360.com)