

Low power dual CMOS voltage comparator

Features

- Wide single supply range or dual supplies 3 V to 16 V or ± 1.5 V to ± 8 V
- Very low supply current: 0.1 mA/comparator independent of supply voltage
- Extremely low input bias current: 1 pA typ
- Extremely low input offset currents: 1 pA typ
- Low input offset voltage
- Input common-mode voltage range includes GND
- Low output saturation voltage 150 mV typical
- Output compatible with TTL, MOS and CMOS
- High input impedance: 10^{12} Ω typical
- Fast response time: 200 ns typ for TTL level input step

Applications

- Battery powered electronics
- General-purpose portable device
- General-purpose low voltage application

Description

These devices consist of two independent precision voltage comparators, designed to operate with single or dual supplies.

These differential comparators use the STMicroelectronics silicon lin MOS process giving them an excellent consumption-speed ratio.

These devices are ideally suited for low consumption applications.

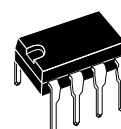

N
DIP8
(plastic package)

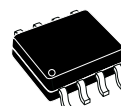

D
SO8
(plastic micropackage)

Pin connections (top view)

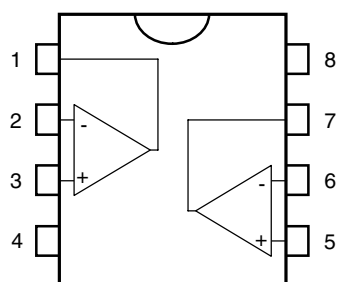

- 1 - Output 1
- 2 - Inverting Input 1
- 3 - Non-inverting Input 1
- 4 - V_{CC}^-
- 5 - Non-inverting Input 2
- 6 - Inverting Input 2
- 7 - Output 2
- 8 - V_{CC}^+

1 Application schematic

Figure 1. Schematic diagram (1/2 TS372)

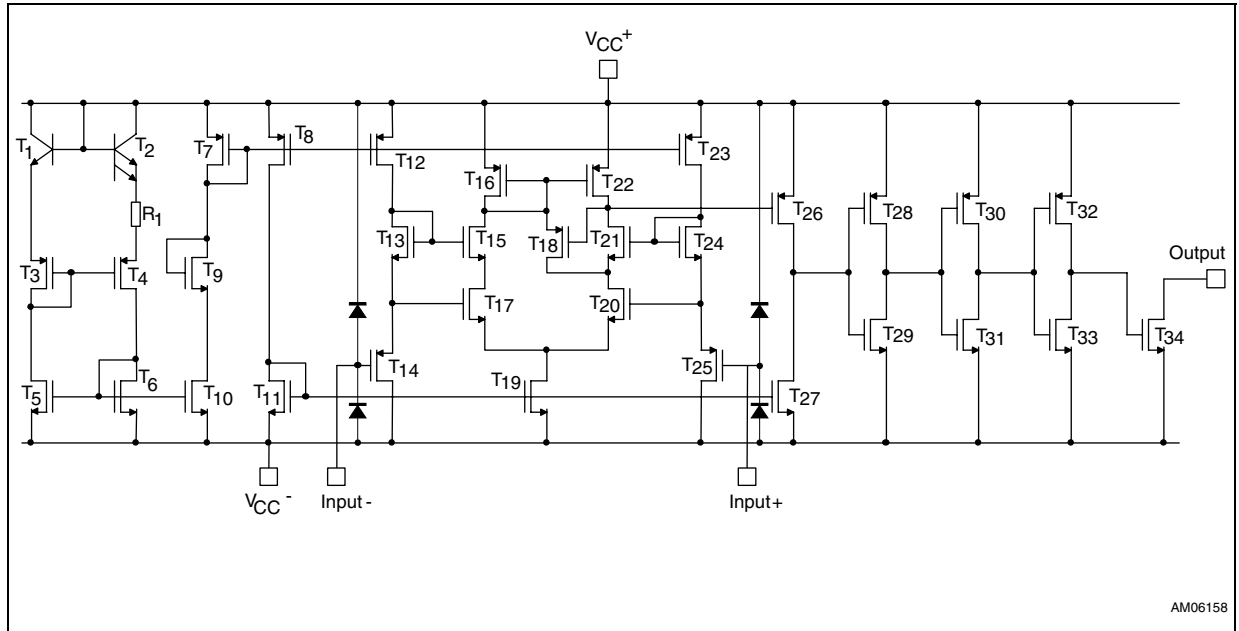

AM06158

2 Absolute maximum ratings and operating conditions

Table 1. Absolute maximum ratings

Symbol	Parameter	Value	Unit
V_{CC+}	Supply voltage ^{(1) (2)}	18	V
V_{id}	Differential input voltage ⁽³⁾	± 18	V
V_i	Input voltage ⁽⁴⁾	18	V
V_o	Output voltage	18	V
I_o	Output current	20	mA
I_F	Forward current in ESD protection diodes on input ⁽⁵⁾	50	mA
	Duration of output circuit to GND ⁽⁶⁾	Infinite	
P_d	Power dissipation ⁽⁷⁾ DIP8 SO8	1250 710	mW
T_{stg}	Storage temperature range	-65 to +150	°C
T_j	Junction temperature	+150	°C

1. Maximum power supply voltage when the comparator is not switching.
2. All voltage values, except differential voltage, are with respect to network ground terminal.
3. Differential voltages are the non-inverting input terminal with respect to the inverting input terminal.
4. The magnitude of the input and the output voltages must never exceed the magnitude of the positive supply voltage.
5. Guaranteed by design.
6. Short-circuit from outputs to V_{CC+} can cause excessive heating and eventual destruction.
7. P_d is calculated with $T_{amb} = +25^\circ\text{C}$, $T_j = +150^\circ\text{C}$ and $R_{thja} = 100^\circ\text{C/W}$ for DIP8 package = 175°C/W for SO-8 package.

Table 2. Operating conditions

Symbol	Parameter	Value	Unit
V_{CC+}	Supply voltage	3 to 16	V
V_{icm}	Input common-mode voltage range ⁽¹⁾ $T_{amb} = 25^\circ\text{C}$ $T_{min} \leq T_{amb} \leq T_{max}$ TS372C TS372I/TS372M	$V_{CC+} - 2$ $V_{CC+} - 2.25$ $V_{CC+} - 2.5$	V
T_{oper}	Operating free-air temperature range TS372C TS372I TS372M	0 to +70 -40 to +125 -55 to +125	°C

1. And input voltages ≤ 12 V.

3 Electrical characteristics

Table 3. Electrical characteristics at $V_{CC+} = 5\text{ V}$, $V_{CC-} = 0\text{ V}$, $T_{amb} = 25^\circ\text{C}$ (unless otherwise specified)

Symbol	Parameter	Min.	Typ.	Max.	Unit
V_{io}	Input offset voltage ($V_{ic} = V_{icm\ min}$) ⁽¹⁾ $T_{amb} = 25^\circ\text{C}$ $T_{min} \leq T_{amb} \leq T_{max}$		2	10 12	mV
I_{io}	Input offset current ⁽²⁾ $T_{amb} = 25^\circ\text{C}$ $T_{min} \leq T_{amb} \leq T_{max}$ TS372C TS372I/TS372M		1	100 200	pA
I_{ib}	Input offset current ⁽²⁾ $T_{amb} = 25^\circ\text{C}$ $T_{min} \leq T_{amb} \leq T_{max}$ TS372C TS372I/TS372M		1	150 300	pA
I_{OH}	High level output current ($V_{id} = 1\text{ V}$) $T_{amb} = 25^\circ\text{C}$ $V_{OH} = 5\text{ V}$ $T_{min} \leq T_{amb} \leq T_{max}$ $V_{OH} = 15\text{ V}$		0.1	1	nA μA
V_{OL}	Low level output voltage ($V_{id} = -1$, $I_{OL} = 4\text{ mA}$) $T_{amb} = 25^\circ\text{C}$ $T_{min} \leq T_{amb} \leq T_{max}$		100	400 700	mV
I_{OL}	Low level output current ($V_{id} = -1$, $V_{OL} = 1.5\text{ V}$)	6	45		mA
I_{CC}	Supply current (each comparator) ($V_{id} = 1\text{ V}$, no load)		150	375	μA

1. The specified offset voltage is the maximum value required to drive the output down to 400 mV or up to 4 V with $R_L = 100\text{ k}\Omega$ to V_{CC+}
2. Maximum values including unavoidable inaccuracies of the industrial test.

Table 4. Switching characteristics ($V_{CC+} = 5\text{ V}$, $T_{amb} = 25^\circ\text{C}$)

Symbol	Parameter	Min.	Typ.	Max.	Unit
t_{re}	Response time ($R_L = 5.1\text{ k}\Omega$ connected to 5 V, $C_L = 15\text{ pF}$) ⁽¹⁾ 100mV input step with 5mV overdrive TTL level input step		600 200		ns

1. The specified response time is the interval between the input signal and the instant when the output signal crosses 1.4 V.

Note: If one of the two channels is not used, it must be configured with a differential input voltage greater than 100 mV to avoid switching.

4 Package information

In order to meet environmental requirements, ST offers these devices in different grades of ECOPACK[®] packages, depending on their level of environmental compliance. ECOPACK[®] specifications, grade definitions and product status are available at: www.st.com. ECOPACK[®] is an ST trademark.

4.1 DIP8 package information

Figure 2. DIP8 package mechanical drawing

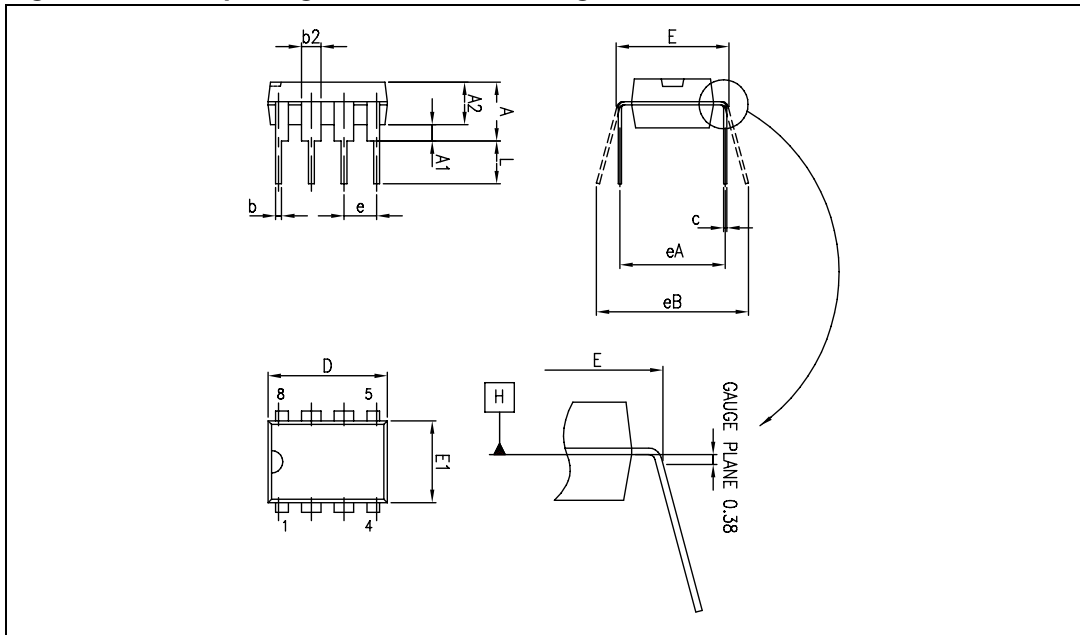

Table 5. DIP8 package mechanical data

Ref.	Dimensions					
	Millimeters			Inches		
	Min.	Typ.	Max.	Min.	Typ.	Max.
A			5.33			0.210
A1	0.38			0.015		
A2	2.92	3.30	4.95	0.115	0.130	0.195
b	0.36	0.46	0.56	0.014	0.018	0.022
b2	1.14	1.52	1.78	0.045	0.060	0.070
c	0.20	0.25	0.36	0.008	0.010	0.014
D	9.02	9.27	10.16	0.355	0.365	0.400
E	7.62	7.87	8.26	0.300	0.310	0.325
E1	6.10	6.35	7.11	0.240	0.250	0.280
e		2.54			0.100	
eA		7.62			0.300	
eB			10.92			0.430
L	2.92	3.30	3.81	0.115	0.130	0.150

4.2 SO-8 package information

Figure 3. SO-8 package mechanical drawing

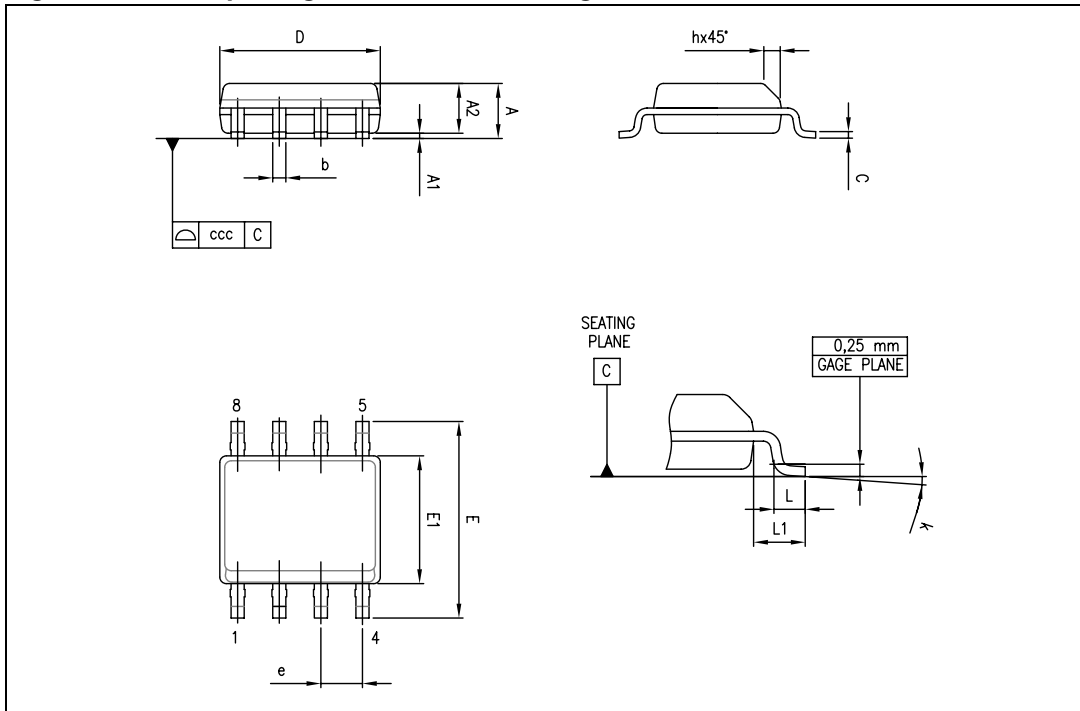

Table 6. SO-8 package mechanical data

Ref.	Dimensions					
	Millimeters			Inches		
	Min.	Typ.	Max.	Min.	Typ.	Max.
A			1.75			0.069
A1	0.10		0.25	0.004		0.010
A2	1.25			0.049		
b	0.28		0.48	0.011		0.019
c	0.17		0.23	0.007		0.010
D	4.80	4.90	5.00	0.189	0.193	0.197
E	5.80	6.00	6.20	0.228	0.236	0.244
E1	3.80	3.90	4.00	0.150	0.154	0.157
e		1.27			0.050	
h	0.25		0.50	0.010		0.020
L	0.40		1.27	0.016		0.050
L1		1.04			0.040	
k	0		8°	1°		8°
ccc			0.10			0.004

5 Ordering information

Table 7. Order codes

Part number	Temperature range	Package	Packing	Marking
TS372CD	0°C, +70°C	SO-8	Tube	
TS372CDT	0°C, +70°C	SO-8	Tape & reel	
TS372CN	0°C, +70°C	DIP8		
TS372ID	-40°C, +125°C	SO-8	Tube	
TS372IDT	-40°C, +125°C	SO-8	Tape & reel	
TS372IN	-40°C, +125°C	DIP8		

6 Revision history

Table 8. Document revision history

Date	Revision	Changes
01-Feb-2002	1	Initial release.
28-Apr-2011	2	Document reformatted. Modified Table 2 , Table 3 and Table 7 .

Please Read Carefully:

Information in this document is provided solely in connection with ST products. STMicroelectronics NV and its subsidiaries ("ST") reserve the right to make changes, corrections, modifications or improvements, to this document, and the products and services described herein at any time, without notice.

All ST products are sold pursuant to ST's terms and conditions of sale.

Purchasers are solely responsible for the choice, selection and use of the ST products and services described herein, and ST assumes no liability whatsoever relating to the choice, selection or use of the ST products and services described herein.

No license, express or implied, by estoppel or otherwise, to any intellectual property rights is granted under this document. If any part of this document refers to any third party products or services it shall not be deemed a license grant by ST for the use of such third party products or services, or any intellectual property contained therein or considered as a warranty covering the use in any manner whatsoever of such third party products or services or any intellectual property contained therein.

UNLESS OTHERWISE SET FORTH IN ST'S TERMS AND CONDITIONS OF SALE ST DISCLAIMS ANY EXPRESS OR IMPLIED WARRANTY WITH RESPECT TO THE USE AND/OR SALE OF ST PRODUCTS INCLUDING WITHOUT LIMITATION IMPLIED WARRANTIES OF MERCHANTABILITY, FITNESS FOR A PARTICULAR PURPOSE (AND THEIR EQUIVALENTS UNDER THE LAWS OF ANY JURISDICTION), OR INFRINGEMENT OF ANY PATENT, COPYRIGHT OR OTHER INTELLECTUAL PROPERTY RIGHT.

UNLESS EXPRESSLY APPROVED IN WRITING BY AN AUTHORIZED ST REPRESENTATIVE, ST PRODUCTS ARE NOT RECOMMENDED, AUTHORIZED OR WARRANTED FOR USE IN MILITARY, AIR CRAFT, SPACE, LIFE SAVING, OR LIFE SUSTAINING APPLICATIONS, NOR IN PRODUCTS OR SYSTEMS WHERE FAILURE OR MALFUNCTION MAY RESULT IN PERSONAL INJURY, DEATH, OR SEVERE PROPERTY OR ENVIRONMENTAL DAMAGE. ST PRODUCTS WHICH ARE NOT SPECIFIED AS "AUTOMOTIVE GRADE" MAY ONLY BE USED IN AUTOMOTIVE APPLICATIONS AT USER'S OWN RISK.

Resale of ST products with provisions different from the statements and/or technical features set forth in this document shall immediately void any warranty granted by ST for the ST product or service described herein and shall not create or extend in any manner whatsoever, any liability of ST.

ST and the ST logo are trademarks or registered trademarks of ST in various countries.

Information in this document supersedes and replaces all information previously supplied.

The ST logo is a registered trademark of STMicroelectronics. All other names are the property of their respective owners.

© 2011 STMicroelectronics - All rights reserved

STMicroelectronics group of companies

Australia - Belgium - Brazil - Canada - China - Czech Republic - Finland - France - Germany - Hong Kong - India - Israel - Italy - Japan - Malaysia - Malta - Morocco - Philippines - Singapore - Spain - Sweden - Switzerland - United Kingdom - United States of America

www.st.com

AMEYA360

Components Supply Platform

Authorized Distribution Brand :



Website :

Welcome to visit www.ameya360.com

Contact Us :

➤ Address :

401 Building No.5, JiuGe Business Center, Lane 2301, Yishan Rd
Minhang District, Shanghai , China

➤ Sales :

Direct +86 (21) 6401-6692

Email amall@ameya360.com

QQ 800077892

Skype [ameyasales1](#) [ameyasales2](#)

➤ Customer Service :

Email service@ameya360.com

➤ Partnership :

Tel +86 (21) 64016692-8333

Email mkt@ameya360.com