

## Demonstration board mounting the L6227Q dual full-bridge driver

Data brief

### Features

- Operating supply voltage from 8 to 52 V
- 2.8 A output peak current (1.4 A DC)
- $R_{DS(on)}$  0.73  $\Omega$  typ. value @  $T_J = 25\text{ }^\circ\text{C}$
- Operating frequency up to 100 kHz
- Non dissipative overcurrent protection
- Dual independent constant  $t_{OFF}$  PWM current controllers
- Slow decay synchronous rectification
- Cross conduction protection
- Thermal shutdown
- Undervoltage lockout
- Integrated fast free wheeling diodes

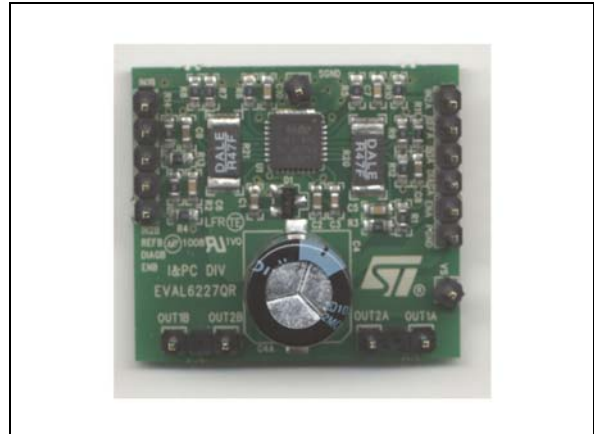

### Description

The L6227Q is a DMOS dual full-bridge designed for motor control applications, realized in BCD multipower technology.

The L6227Q features thermal shutdown and a non-dissipative overcurrent protection on the high-side power MOSFETs plus a diagnostic output that can be easily used to implement the overcurrent protection.

The device also includes two independent constant off-time PWM current controllers which perform the chopping regulation.

# 1 Board description

**Table 1. EVAL6227QR electrical specifications (recommended values)**

Parameter	Value
Supply voltage range (VS)	8 to 52 Vdc
Output current rating (OUTx)	up to 1.4 A <sub>r.m.s.</sub>
Switching frequency	up to 100 kHz
Input and enable voltage range	0 to + 5 V
Voltage reference range (REFA, REFB)	0 to + 5 V
L6227Q thermal resistance junction-to-ambient	42 °C/W

**Figure 1. EVAL6227QR demonstration board description**

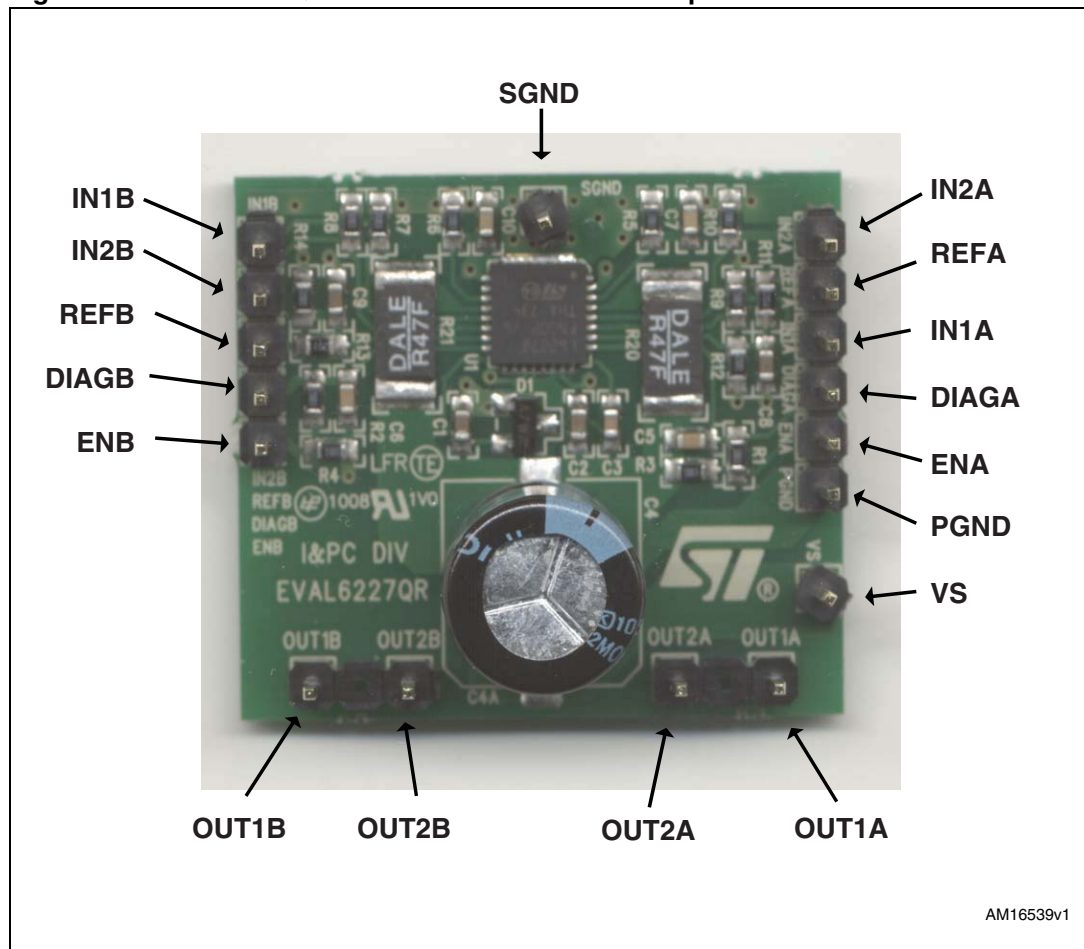

AM16539v1

**Table 2. EVAL6227QR pin connections**

Name	Type	Function
VS	Power supply	Bridge A and bridge B power supply
PGND	Ground	Power ground terminal
IN1A	Logic input	Bridge A logic input 1
IN2A	Logic input	Bridge A logic input 2
ENA	Logic input	Bridge A enable (active high). When low, the power DMOSs of bridge A are switched OFF.
IN1B	Logic input	Bridge B logic input 1
IN2B	Logic input	Bridge B logic input 2
ENB	Logic input	Bridge B enable (active high). When low, the power DMOSs of bridge B are switched OFF.
DIAGA	Open drain output	Bridge A diagnostic pin. When low, an overcurrent or overtemperature event of bridge A is signaled.
DIAGB	Open drain output	Bridge B diagnostic pin. When low, an overcurrent or overtemperature event of bridge B is signaled.
SGND	Ground	Signal ground terminal
REFA	Analog input	Bridge A current controller reference voltage
REFB	Analog input	Bridge B current controller reference voltage
OUT1A	Power output	Bridge A output 1
OUT2A	Power output	Bridge A output 2
OUT1B	Power output	Bridge B output 1
OUT2B	Power output	Bridge B output 2

Figure 2. EVAL6227QR demonstration board schematic

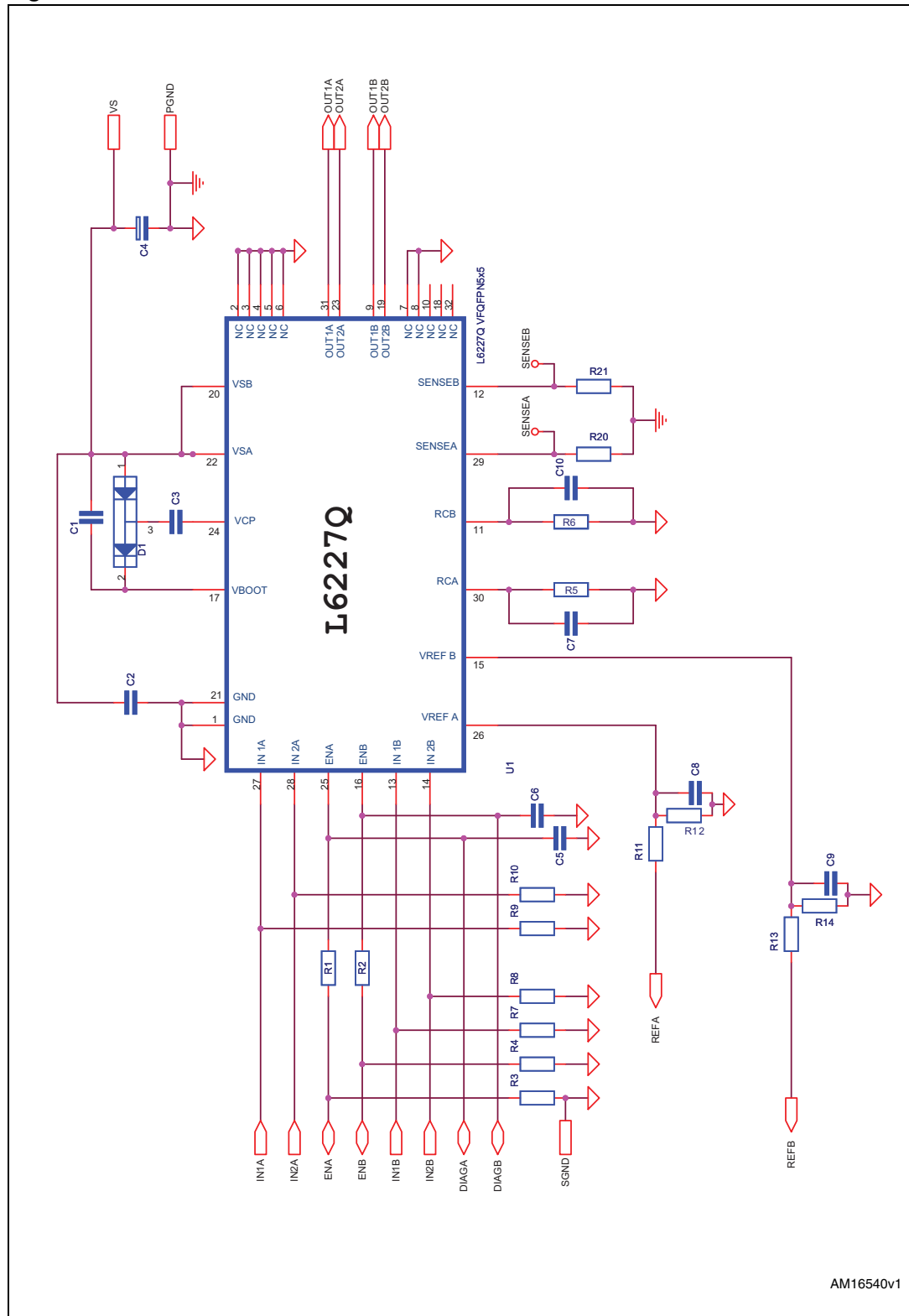

Table 3. EVAL6227QR part list

Part reference	Part value	Part description
C1	220 nF/25 V	Capacitor
C2	220 nF/63 V	Capacitor
C3	10 nF/25 V	Capacitor
C4	100 μF/63 V	Capacitor
C5, C6	5.6 nF	Capacitor
C7, C10	820 pF	Capacitor
C8, C9	220 nF	Capacitor
D1	BAT46SW	Diode
R1, R2, R3, R4, R7, R8, R9, R10	100 kΩ, 5%, 0.25 W	Resistor
R5, R6	100 kΩ, 1%, 0.25 W	Resistor
R11, R13	20 kΩ, 5 %, 0.25 W	Resistor
R12, R14	2 kΩ, 5 %, 0.25 W	Resistor
R20, R21	0.4 Ω, 1 W	Resistor
U1	L6227Q	Dual full-bridge in VFQFPN5x5

Figure 3. Component placement

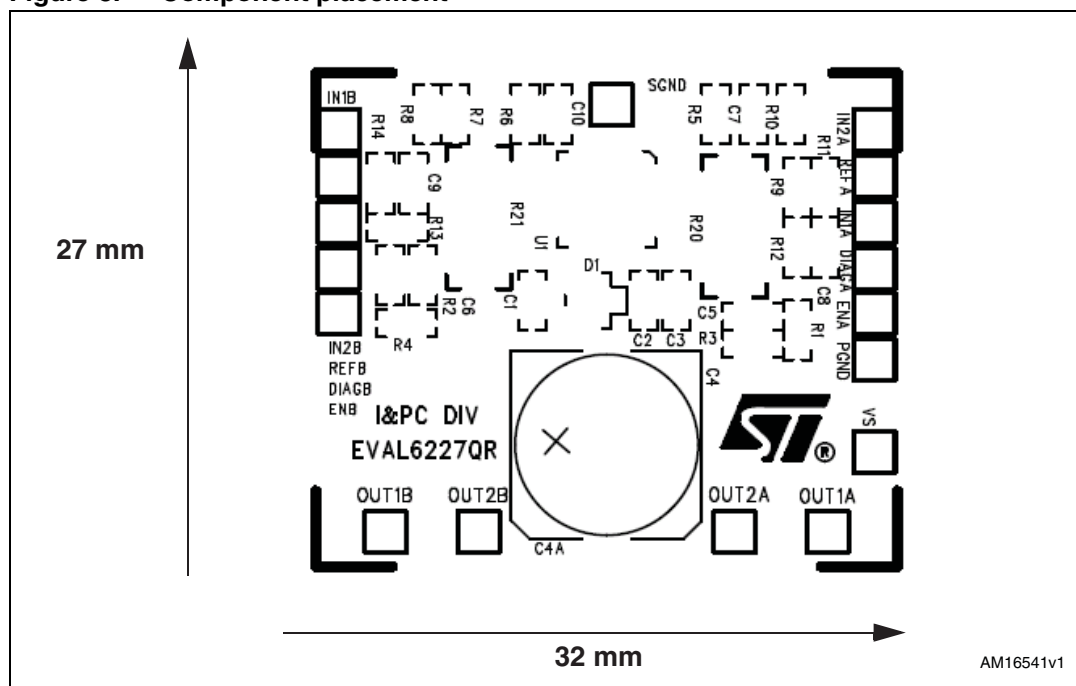

Figure 4. Top layer layout

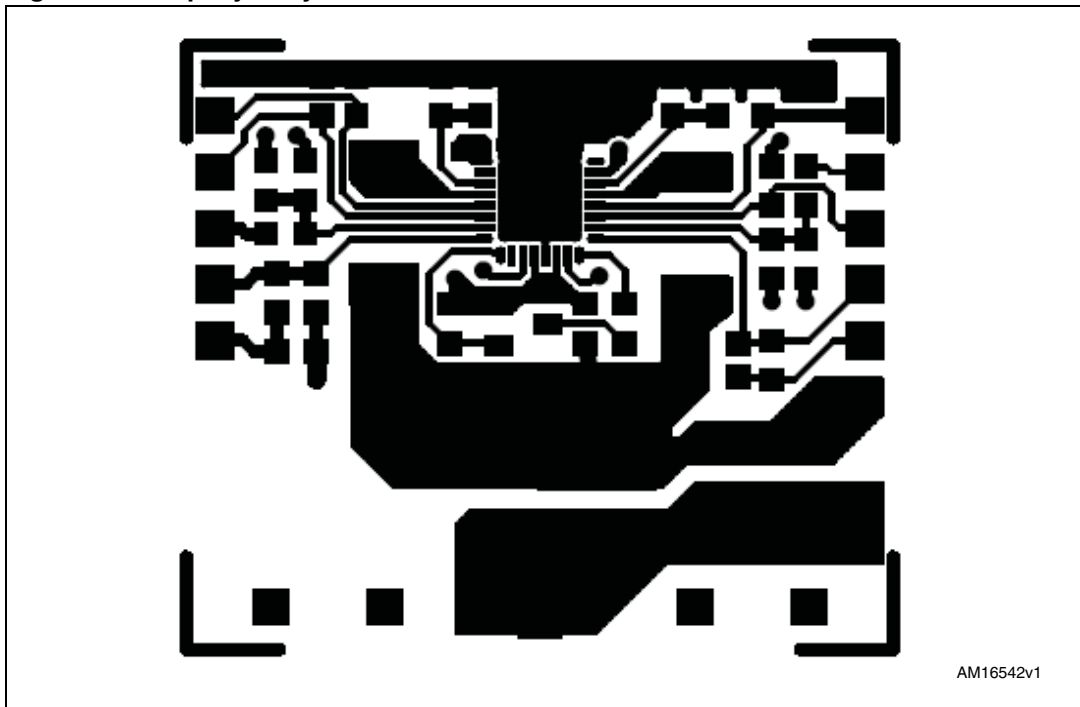
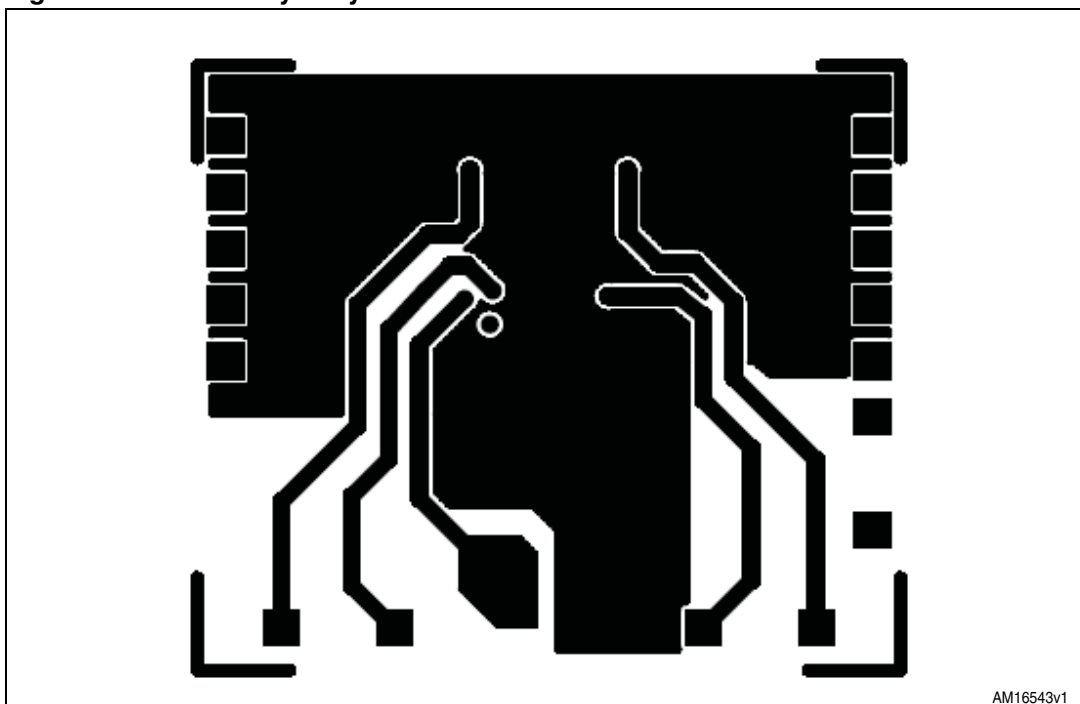

Figure 5. Bottom layer layout



## 2 Revision history

**Table 4. Document revision history**

Date	Revision	Changes
09-Jan-2013	1	Initial release.

**Please Read Carefully:**

Information in this document is provided solely in connection with ST products. STMicroelectronics NV and its subsidiaries ("ST") reserve the right to make changes, corrections, modifications or improvements, to this document, and the products and services described herein at any time, without notice.

All ST products are sold pursuant to ST's terms and conditions of sale.

Purchasers are solely responsible for the choice, selection and use of the ST products and services described herein, and ST assumes no liability whatsoever relating to the choice, selection or use of the ST products and services described herein.

No license, express or implied, by estoppel or otherwise, to any intellectual property rights is granted under this document. If any part of this document refers to any third party products or services it shall not be deemed a license grant by ST for the use of such third party products or services, or any intellectual property contained therein or considered as a warranty covering the use in any manner whatsoever of such third party products or services or any intellectual property contained therein.

**UNLESS OTHERWISE SET FORTH IN ST'S TERMS AND CONDITIONS OF SALE ST DISCLAIMS ANY EXPRESS OR IMPLIED WARRANTY WITH RESPECT TO THE USE AND/OR SALE OF ST PRODUCTS INCLUDING WITHOUT LIMITATION IMPLIED WARRANTIES OF MERCHANTABILITY, FITNESS FOR A PARTICULAR PURPOSE (AND THEIR EQUIVALENTS UNDER THE LAWS OF ANY JURISDICTION), OR INFRINGEMENT OF ANY PATENT, COPYRIGHT OR OTHER INTELLECTUAL PROPERTY RIGHT.**

**UNLESS EXPRESSLY APPROVED IN WRITING BY TWO AUTHORIZED ST REPRESENTATIVES, ST PRODUCTS ARE NOT RECOMMENDED, AUTHORIZED OR WARRANTED FOR USE IN MILITARY, AIR CRAFT, SPACE, LIFE SAVING, OR LIFE SUSTAINING APPLICATIONS, NOR IN PRODUCTS OR SYSTEMS WHERE FAILURE OR MALFUNCTION MAY RESULT IN PERSONAL INJURY, DEATH, OR SEVERE PROPERTY OR ENVIRONMENTAL DAMAGE. ST PRODUCTS WHICH ARE NOT SPECIFIED AS "AUTOMOTIVE GRADE" MAY ONLY BE USED IN AUTOMOTIVE APPLICATIONS AT USER'S OWN RISK.**

Resale of ST products with provisions different from the statements and/or technical features set forth in this document shall immediately void any warranty granted by ST for the ST product or service described herein and shall not create or extend in any manner whatsoever, any liability of ST.

ST and the ST logo are trademarks or registered trademarks of ST in various countries.

Information in this document supersedes and replaces all information previously supplied.

The ST logo is a registered trademark of STMicroelectronics. All other names are the property of their respective owners.

© 2013 STMicroelectronics - All rights reserved

STMicroelectronics group of companies

Australia - Belgium - Brazil - Canada - China - Czech Republic - Finland - France - Germany - Hong Kong - India - Israel - Italy - Japan - Malaysia - Malta - Morocco - Philippines - Singapore - Spain - Sweden - Switzerland - United Kingdom - United States of America

[www.st.com](http://www.st.com)

# AMEYA360

## Components Supply Platform

Authorized Distribution Brand :



Website :

Welcome to visit [www.ameya360.com](http://www.ameya360.com)

Contact Us :

➤ Address :

401 Building No.5, JiuGe Business Center, Lane 2301, Yishan Rd  
Minhang District, Shanghai , China

➤ Sales :

Direct +86 (21) 6401-6692

Email [amall@ameya360.com](mailto:amall@ameya360.com)

QQ 800077892

Skype [ameyasales1](#) [ameyasales2](#)

➤ Customer Service :

Email [service@ameya360.com](mailto:service@ameya360.com)

➤ Partnership :

Tel +86 (21) 64016692-8333

Email [mkt@ameya360.com](mailto:mkt@ameya360.com)