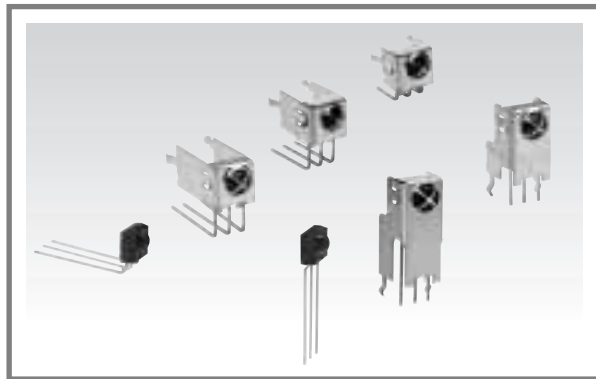
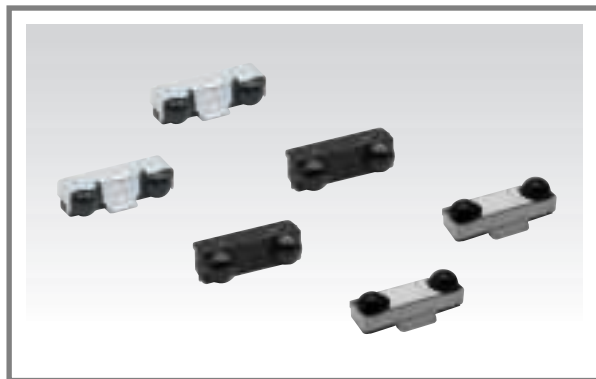

Photo Link Modules



Remote Control Receiver Module



IrDA Infrared Communication Module

Remote Control Receiver Module

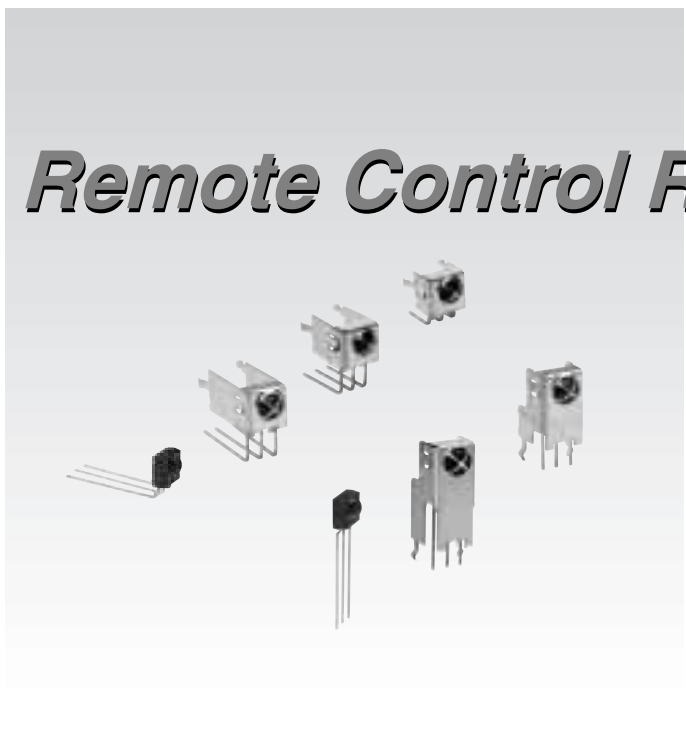

Remote Control Receiver Module

■ Contents

Remote Control Receiver Module Selection Guide	1
RPM7200 Series	3
RPM7100 Series	5
External Dimensions	7
Basic Knowledge of Remote Control	9
Remote Control Receiver Module and Data Communication	10
Block Diagram and Work of Remote Control Receiver Module	11
Remote Control Transmission Signal	13
Precautions for Designing Transmitter Side	15
Precautions for Designing Receiver Side	17
Receiving Discrimination Method to Expand Effective Distance	21
Measures for Preventing Malfunctions	22

Remote Control Receiver Module Selection Guide

Remote Control Receiver Module (at 3.0 to 3.3V)

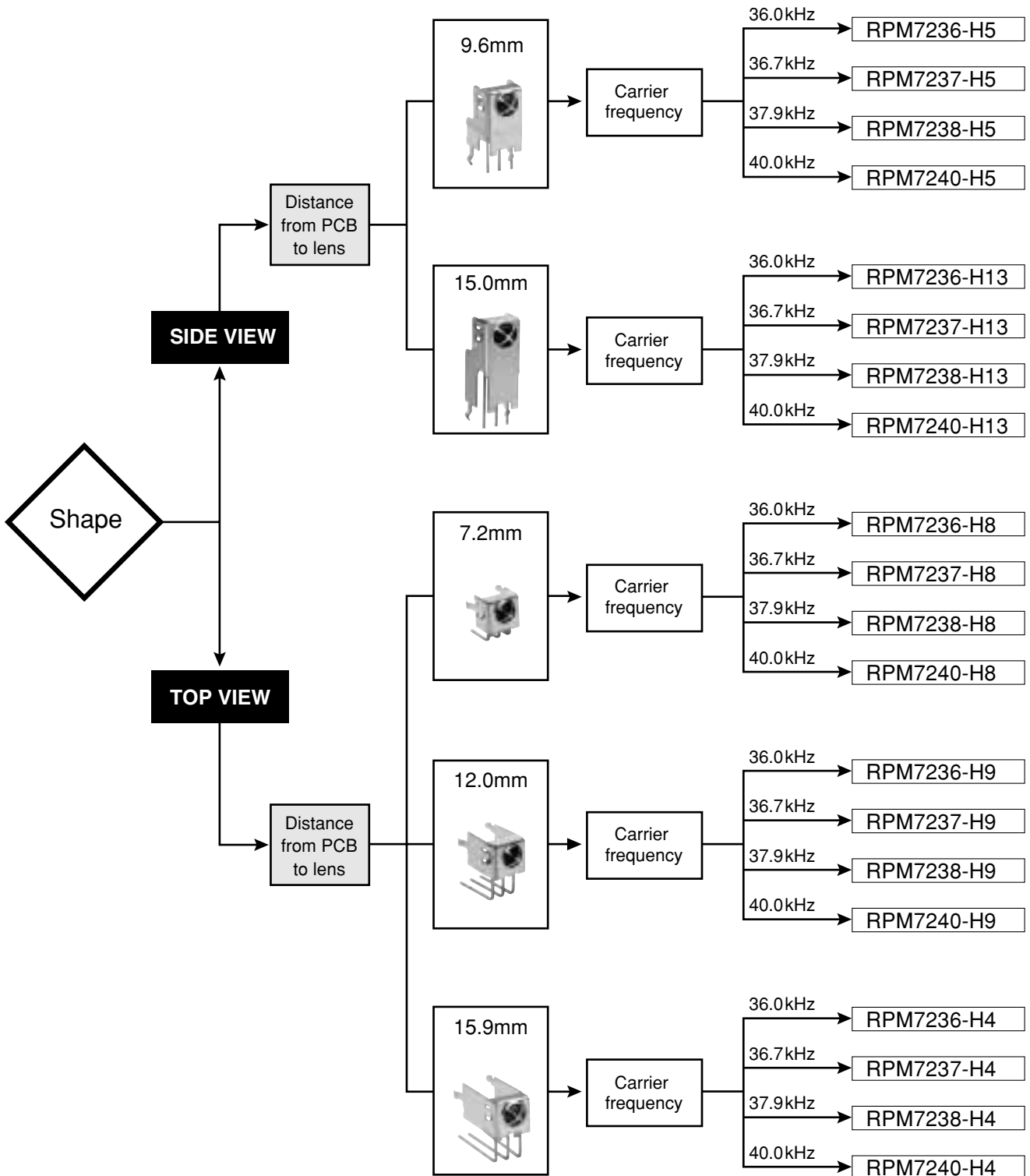

Remote Control Receiver Module (at 5.0V)

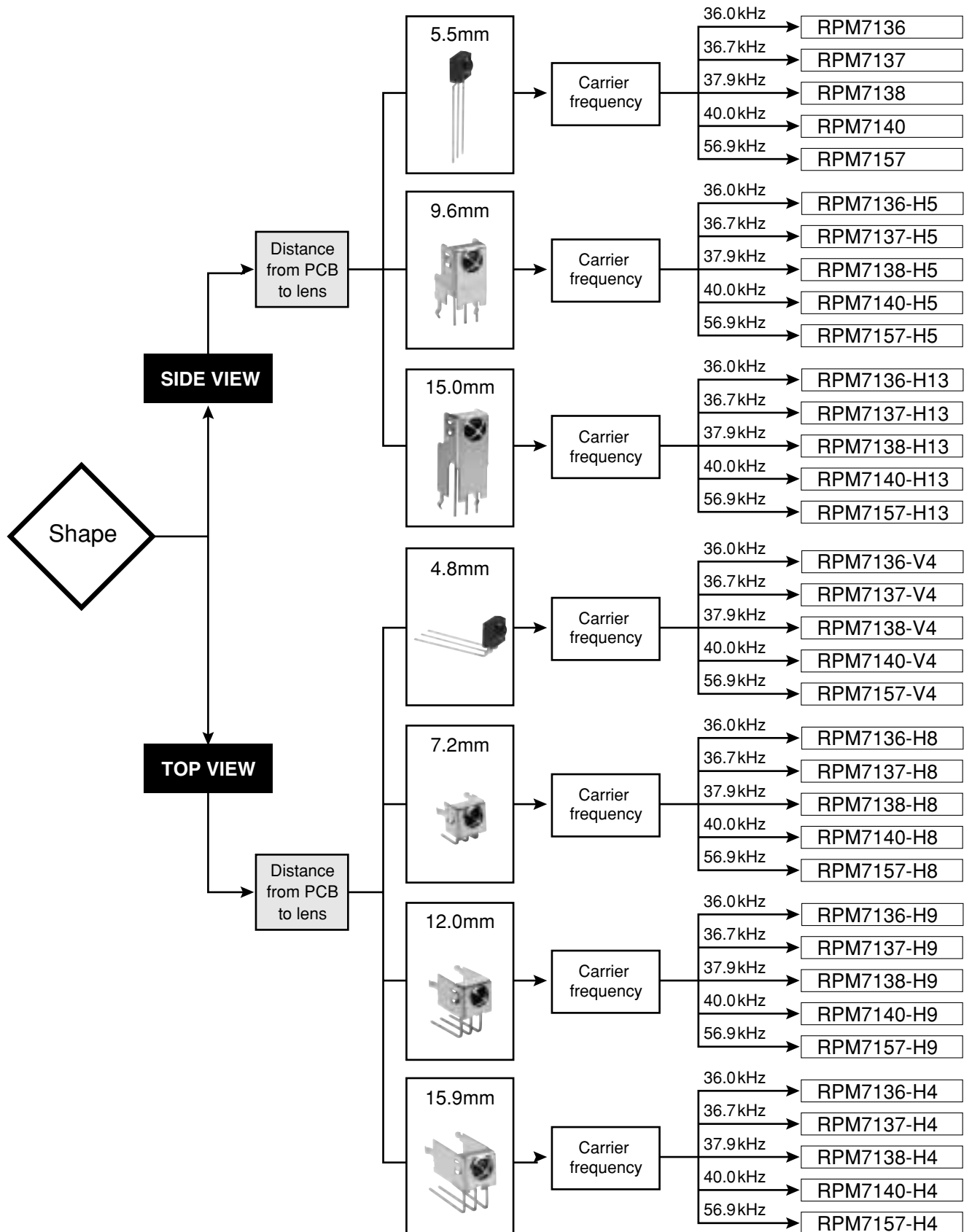

■Electrical and Optical Characteristics of RPM7200 Series

Absolute Maximum Ratings (Ta=25°C)

Parameter	Symbol	Limits	Unit
Supply Voltage	V _{CC}	6.3	V
Storage Temperature Range	T _{stg}	-30~+100	°C
Operating Temperature Range	T _{opr}	-10~+75	°C
Solder Temperature	T _{sol}	260*	°C

* Within 5s and 3mm of the route of the lead.

Recommended Operating Conditions (Ta=25°C)

Parameter	Symbol	Min.	Typ.	Max.	Unit
Supply Voltage	V _{CC}	2.7	3.0	3.6	V

Electrical Characteristics (Ta=25°C and V_{CC}=3V unless otherwise specified)

Parameter	Symbol	Min.	Typ.	Max.	Unit	Conditions
Current Consumption	I _{CC}	—	0.3	0.5	mA	With no external light or input
Effective Distance on Axis	L	8	15	—	m	*1 External light condition E _e <10 lx
High Level Output Voltage	V _H	2.5	—	—	V	*1
Low Level Output Voltage	V _L	—	—	0.5	V	*1 I _{sink} =200μA max.
ON Pulse Width	T _{ON}	400	600	800	μs	*1 External light condition E _e <10 lx
OFF Pulse Width	T _{OFF}	400	600	800	μs	*1 External light condition E _e <10 lx
Horizontal Half Angle	θ _{1/2}	—	45	—	deg	*2
Vertical Half Angle	θ _{1/2}	—	35	—	deg	*2

*1. Burst waves (600/600μs) are transmitted by a standard transmitter, and the 100th and later pulses are measured.

*2. A directional angle where the effective distance is half the linear arrival distance.

Shape	Side View		Top View		
	RSIP-A3 (H5)	RSIP-A3 (H13)	RSIP-A3 (H8)	RSIP-A3 (H9)	RSIP-A3 (H4)
Package					
Hight (PCB to LENS)	9.6mm	15.0mm	7.2mm	12.0mm	15.9mm

Carrier Frequency

36.0kHz	RPM7236-H5	RPM7236-H13	RPM7236-H8	RPM7236-H9	RPM7236-H4
36.7kHz	RPM7237-H5	RPM7237-H13	RPM7237-H8	RPM7237-H9	RPM7237-H4
37.9kHz	RPM7238-H5	RPM7238-H13	RPM7238-H8	RPM7238-H9	RPM7238-H4
40.0kHz	RPM7240-H5	RPM7240-H13	RPM7240-H8	RPM7240-H9	RPM7240-H4

Typical Characteristics of RPM7200 Series

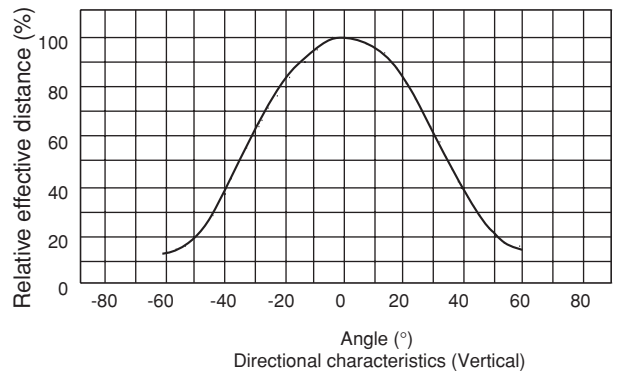
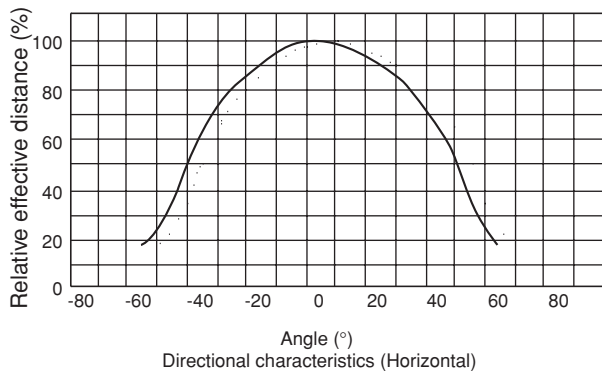
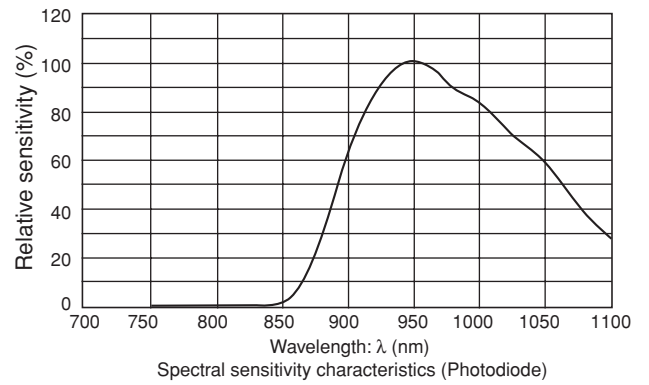
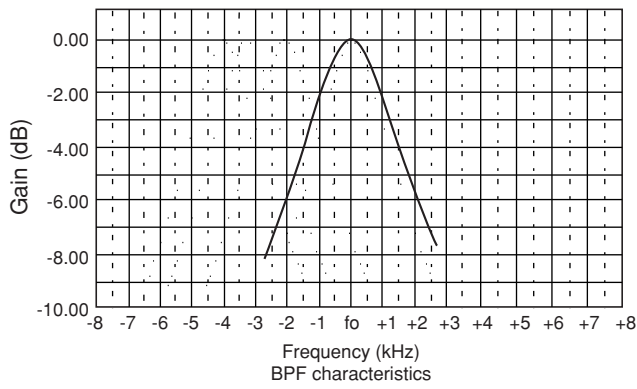

Remote Control Receiver Module

■Electrical and Optical Characteristics of RPM7100 Series

Absolute Maximum Ratings (Ta=25°C)

Parameter	Symbol	Limits	Unit
Supply voltage	V _{CC}	6.3	V
Storage Temperature Range	T _{stg}	-30~+100	°C
Operating Temperature Range	T _{opr}	-10~+75	°C
Solder Temperature	T _{sol}	260*	°C

* Within 5s and 3mm of the route of the lead.

Recommended Operating Conditions (Ta=25°C)

Parameter	Symbol	Min.	Typ.	Max.	Unit
Supply Voltage	V _{CC}	4.5	5.0	5.5	V

Electrical Characteristics (Ta=25°C and V_{CC}=5V unless otherwise specified)

Parameter	Symbol	Min.	Typ.	Max.	Unit	Conditions
Current Consumption	I _{CC}	—	0.95	1.5	mA	With no external light or input
Effective Distance on Axis	L	8	15	—	m	*1 External light condition E _e <10 lx
High Level Output Voltage	V _H	4.5	—	—	V	*1
Low Level Output Voltage	V _L	—	—	0.5	V	*1 I _{sink} =200μA max.
ON Pulse Width	T _{ON}	400	600	800	μs	*1 External light condition E _e <10 lx
OFF Pulse Width	T _{OFF}	400	600	800	μs	*1 External light condition E _e <10 lx
Horizontal Half Angle	θ _{1/2}	—	45	—	deg	*2
Vertical Half Angle	θ _{1/2}	—	35	—	deg	*2

*1. Burst waves (600/600μs) are transmitted by a standard transmitter, and the 100th and later pulses are measured.

*2. A directional angle where the effective distance is half the linear arrival distance.

Shape	Side View			Top View			
	RSIP-A3	RSIP-A3 (H5)	RSIP-A3 (H13)	RSIP-A3 V4	RSIP-A3 (H8)	RSIP-A3 (H9)	RSIP-A3 (H4)
Hight (PCB to LENS)	5.5mm	9.6mm	15.0mm	4.8mm	7.2mm	12.0mm	15.9mm

Carrier Frequency

36.0kHz	RPM7136	RPM7136-H5	RPM7136-H13	RPM7136-V4	RPM7136-H8	RPM7136-H9	RPM7136-H4
36.7kHz	RPM7137	RPM7137-H5	RPM7137-H13	RPM7137-V4	RPM7137-H8	RPM7137-H9	RPM7137-H4
37.9kHz	RPM7138	RPM7138-H5	RPM7138-H13	RPM7138-V4	RPM7138-H8	RPM7138-H9	RPM7138-H4
40.0kHz	RPM7140	RPM7140-H5	RPM7140-H13	RPM7140-V4	RPM7140-H8	RPM7140-H9	RPM7140-H4
56.9kHz	RPM7157	RPM7157-H5	RPM7157-H13	RPM7157-V4	RPM7157-H8	RPM7157-H9	RPM7157-H4

■ Typical Characteristics of RPM7100 Series

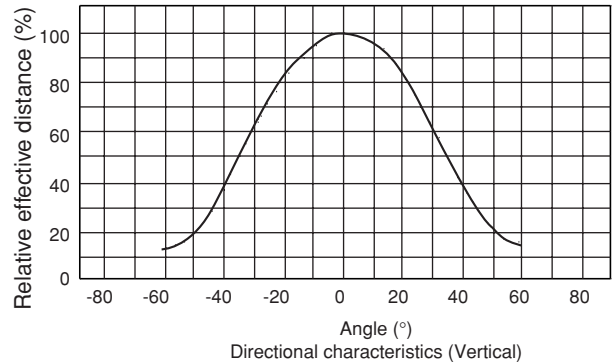
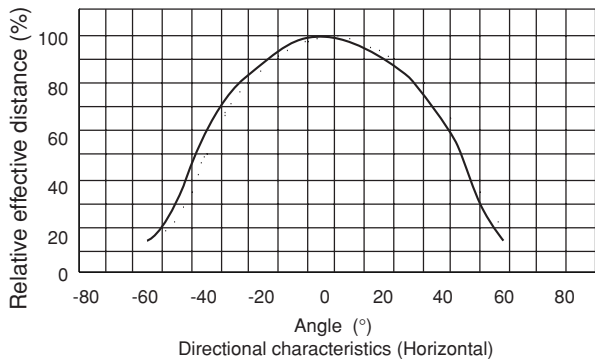
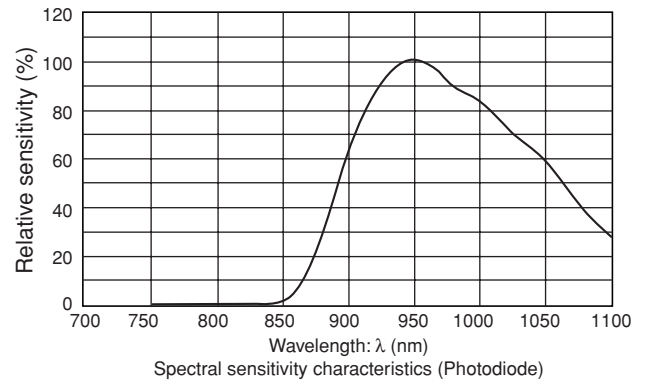
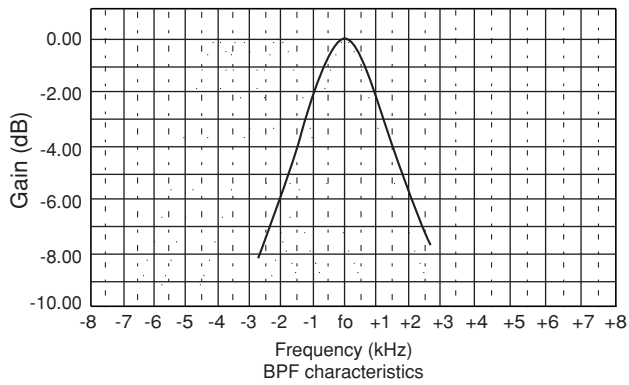

External Dimensions (Unit: mm)

●RSIP-A3 (H13)

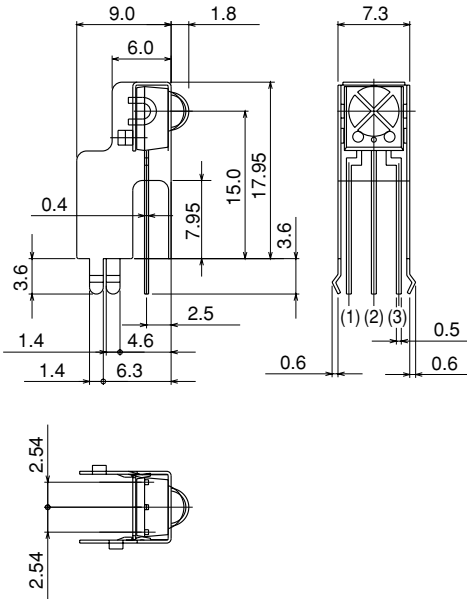

●RSIP-A3 (H4)

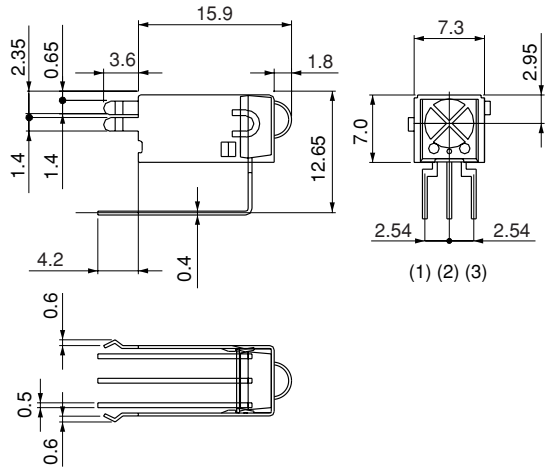

●RSIP-A3 (H5)

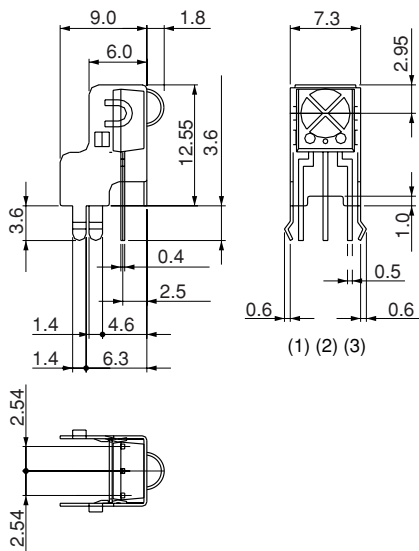

●RSIP-A3

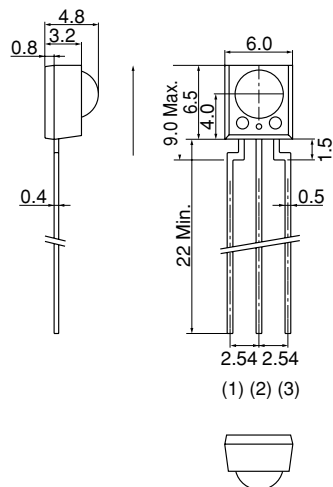

Pin number	
(1)	Rout
(2)	GND
(3)	Vcc

●RSIP-A3 V4

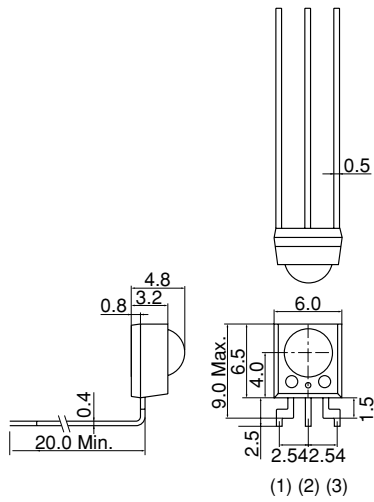

●RSIP-A3 (H8)

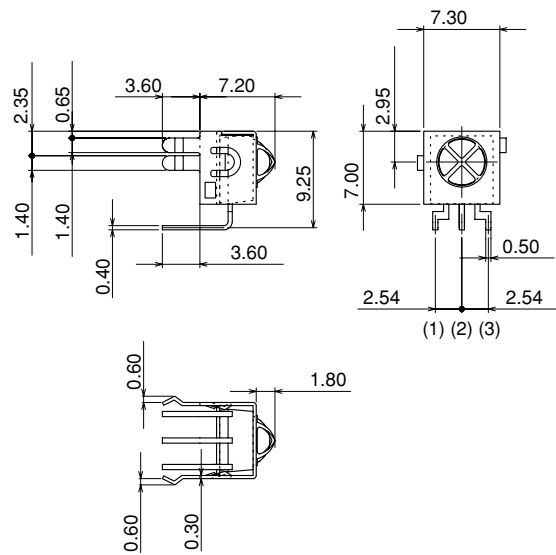

●RSIP-A3 (H9)

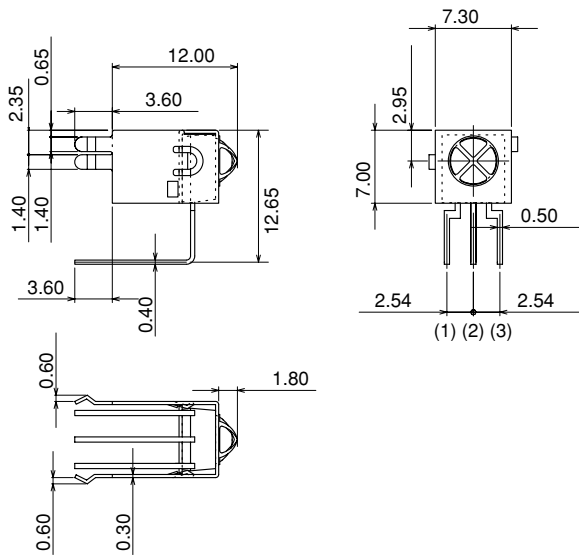

Pin number	
(1)	Rout
(2)	GND
(3)	Vcc

1. Basic Knowledge of Remote Control

1) Remote Control Receiver Module

The Remote Control Receiver Module is an optical communications module that uses infrared rays for TV sets and audio equipment.

Conventional models were of cubic structure (1.5 × 1.5cm) incorporating a PCB mounted with a PIN photodiode, receiver IC, and capacitors and covered with a shield casing. Since ROHM released a one-package model, however, mold resin models of one-package structure have been mainstream products.

ROHM provides the RPM7100-Hx Series (operating at 5V) and the RPM7200-Hx Series (operating at 3.0V). Both of them are of two-chip structure incorporating a PIN photodiode and receiver IC.

ROHM's Remote Control Receiver Module prevents malfunctions caused by power line noise by taking measures for a reduction in power supply ripples, thus suiting a variety of power supply environments flexibly.

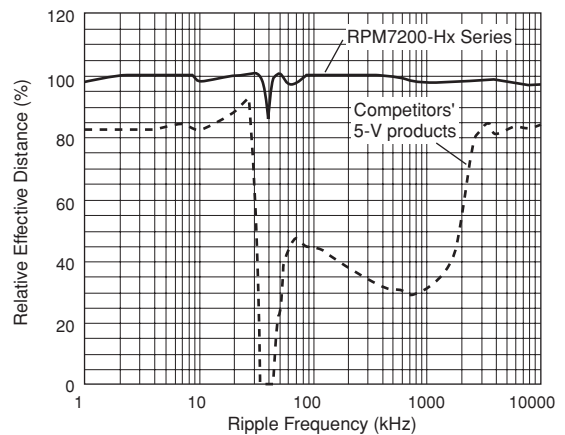

Fig. 1 Relative Effective Distance vs. Power Supply Ripple Frequency of RPM7200-Hx

2) Remote Control Optical Signal

The remote control uses an infrared optical signal.

Infrared rays are invisible and longer in wavelength than visible light.

Remote control models use a dominant wavelength around 950nm.

3) Reason for Use of Infrared Rays

The remote control is overwhelmingly used indoors under light emitted from lighting apparatus, which includes quantities of visible light components. In order to prevent such light from becoming a noise source, the remote control uses infrared rays, which is rarely included in the light emitted from the lighting apparatus.

In other words, the remote control uses infrared rays in order to improve the signal-to-noise ratio. The RPM7100-Hx Series and RPM7200-Hx Series eliminate optical noise by providing the resin packages with a filter function that shuts off visible light.

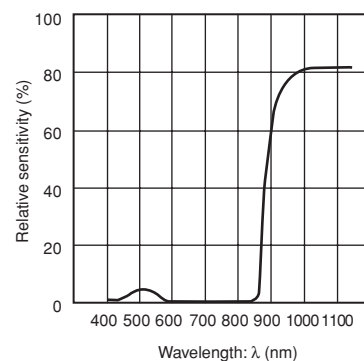

Fig. 2 Relative Sensitivity of RPM7100-Hx/RPM7200-Hx

2. Remote Control Receiver Module and Data Communication

1) Structure of Remote Control Receiver Module

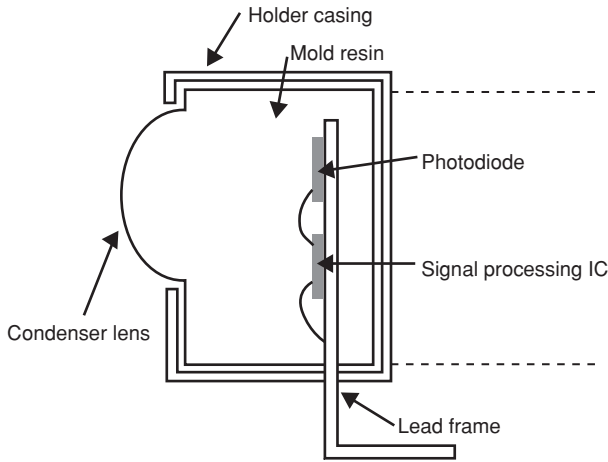
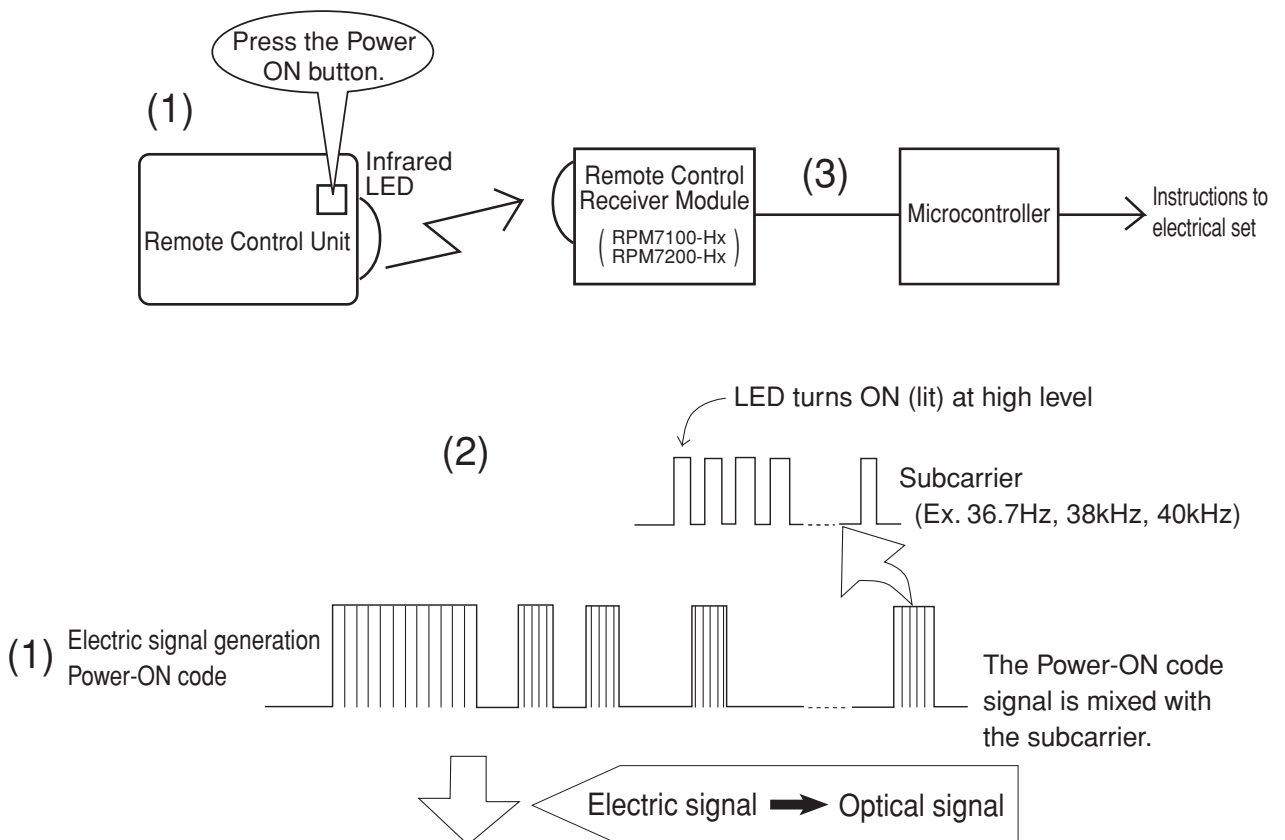

Fig. 3 Structure of RPM7100-Hx/RPM7200-Hx

The photodiode and the signal processing IC are die-bonded to the metal lead frame. Then gold wires are bonded for necessary wiring. The parts are sealed with mold resin to shut off visible optical noise, and the whole structure except the condenser lens is covered with a metal shield casing.

2) Remote Control System Signal Flow

The Remote Control Receiver Module receives an optical signal from the Remote Control Unit and changes the signal into an electric signal.



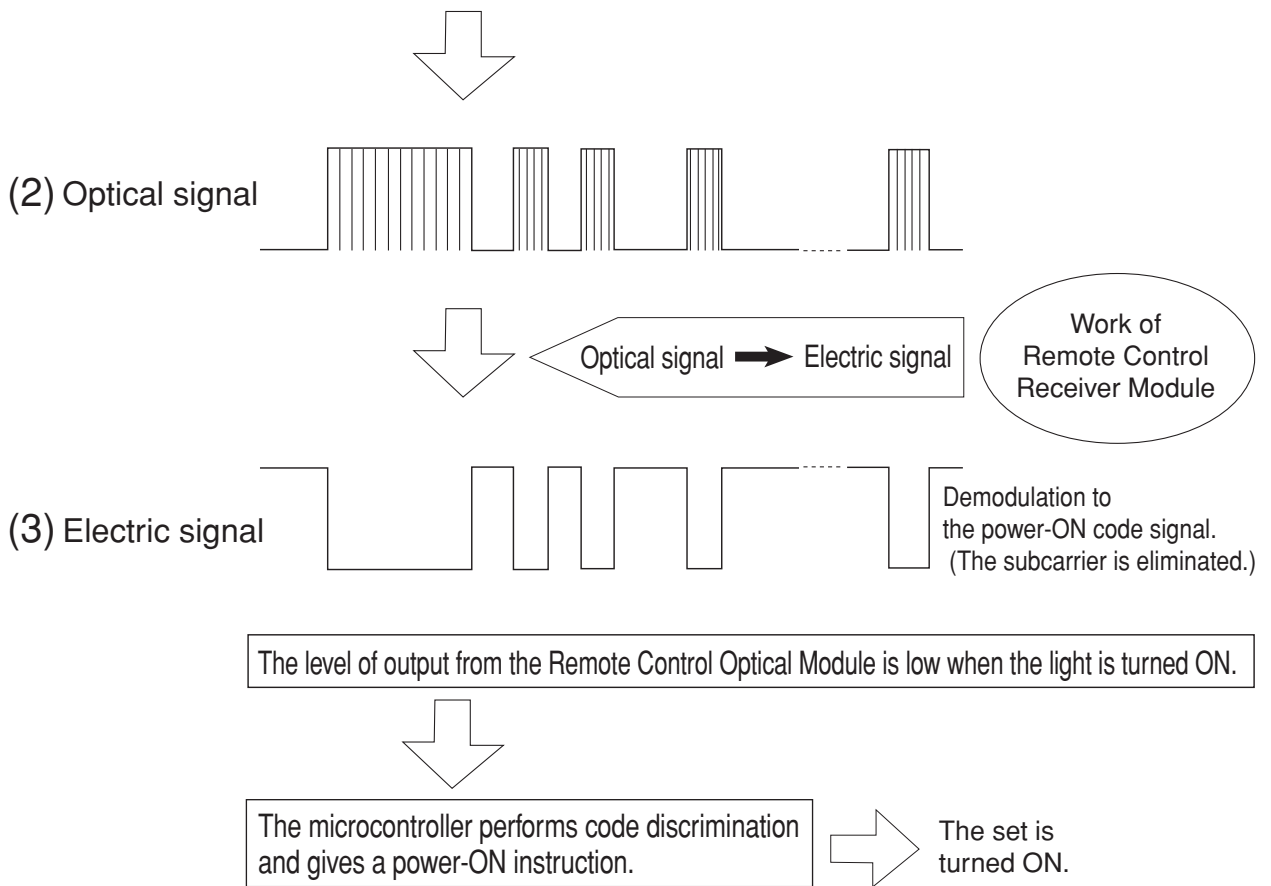

Fig. 4

3. Block Diagram and Work of Remote Control Receiver Module

1) Block Diagram of Remote Control Receiver Module

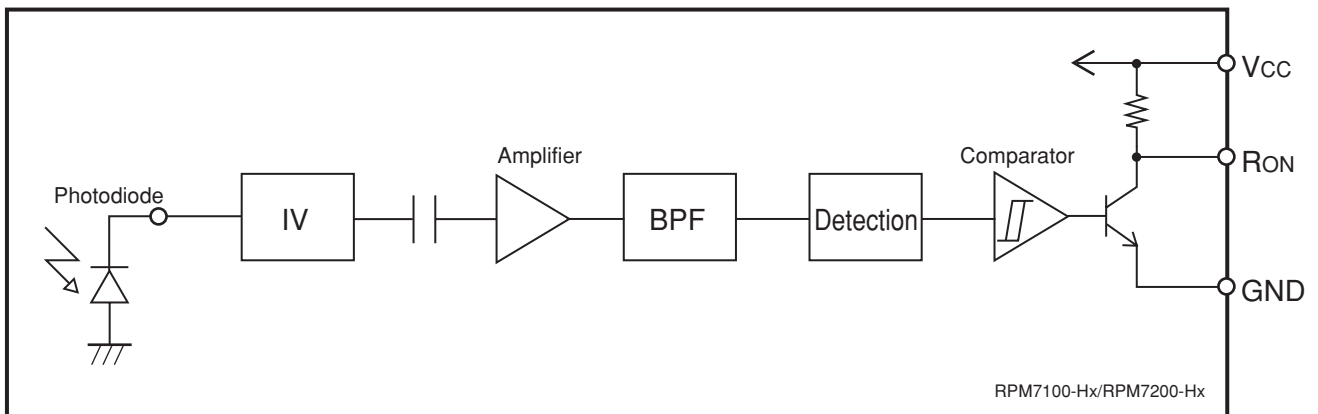

Fig. 5 Block Diagram

2) Work of Each Blocks

• Photodiode

The photodiode receives an optical signal transmitted from the remote control unit and converts the optical signal into a current signal. The mold resin of the Remote Control Receiver Module has a function to shut off visible light, thus allowing only the optical signal to pass.

Figure 6 shows the spectral sensitivity characteristics of the mold resin and photodiode.

• IV

The optical signal received by the photodiode and converted into the current signal is further converted into a voltage signal. An automatic gain control function is provided to suppress excessively strong optical signal input so that the signal will be within the permissible range of the circuits.

• Amplifier

The IV block amplifies the voltage signal converted from the current signal to optimum amplitude for the later stages where the signal is further processed. If the input is excessively high, the amplitude will be limited in the IV block.

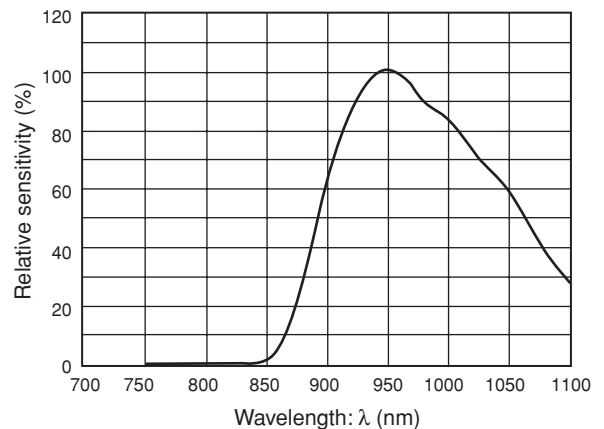

Fig. 6 Relative Spectral Sensitivity Characteristics of RPM7100-Hx/RPM7200-Hx

• BPF (Band Pass Filter)

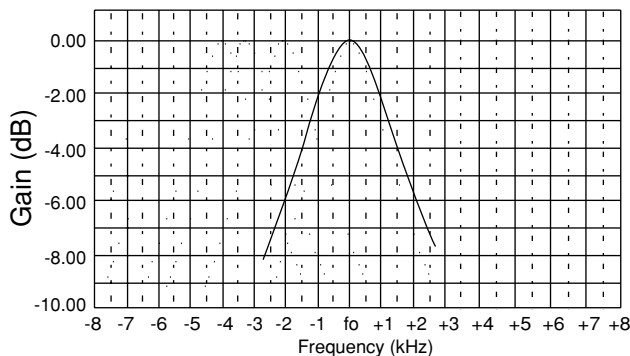

Fig. 7 BPF Characteristics of RPM7100-Hx/RPM7200-Hx

The remote transmission signal is modulated by the subcarrier. The BPF is incorporated in order to extract only pure signal components from the signal (including noise) received.

- Detection

This block has a detector and integrator.

The detector automatically determines the level of detection (a) according to the level of BPF output, and sets the timing of integration.

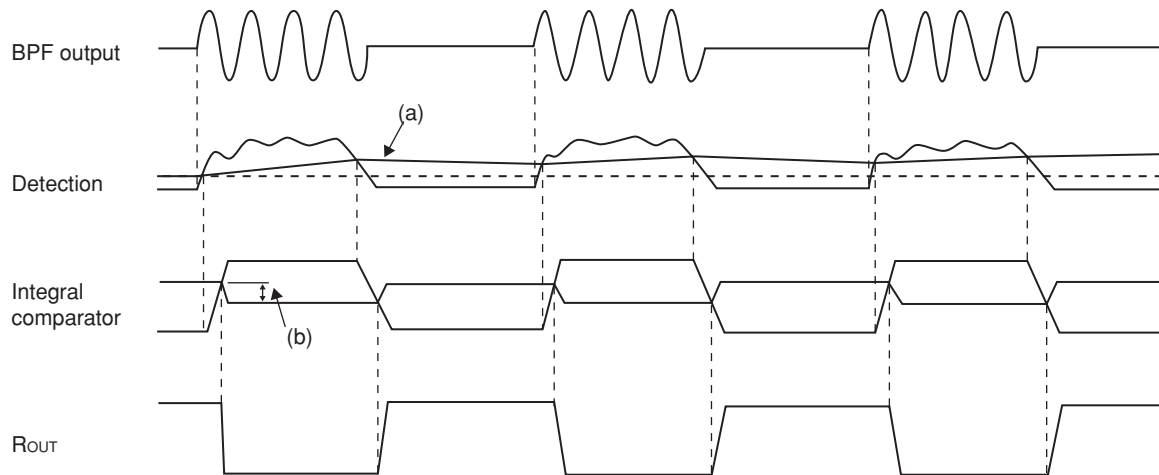

Fig. 8 Waveform Shaping of RPM7100-Hx/RPM7200-Hx

Only the pure signal is extracted from the input signal that includes noise, at which time the level of detection is automatically adjusted according to the output amplitude of the BPF.

- Comparator

The output of the detection block is converted into a binary. The hysteresis (b) prevents chattering that results from noise.

4. Remote Control Transmission Signal

Various methods are used for signal transmission, because there are no unified standards. The same PPM (pulse position modulation) code is used to discriminate 1 and 0 according to the pulse time interval.

The amplitude of the subcarrier is modified according to the pulse train. Therefore, the subcarrier frequency range is between 33 and 57kHz.

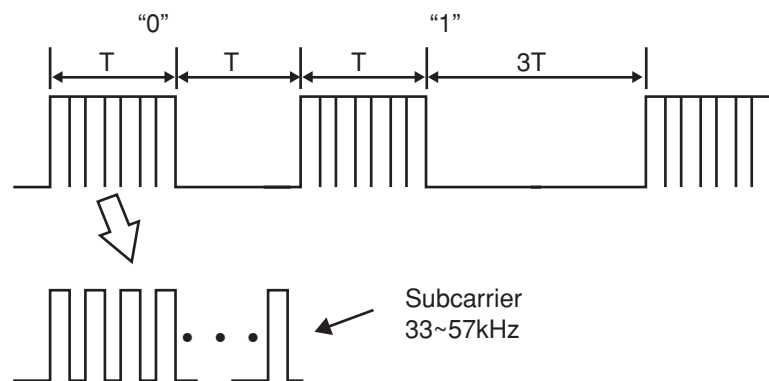

Fig. 9

«Overview of AEHA's (Association for Electric Home Appliances) Format»

Application: Applicable to infrared remote control systems for home appliances with a subcarrier range up to 40kHz employed to transmit data.

Subcarrier: 33kHz and 40kHz max.

Signal format: A frame includes a leader, custom code, parity, data code, and trailer, the outline of which is shown below.

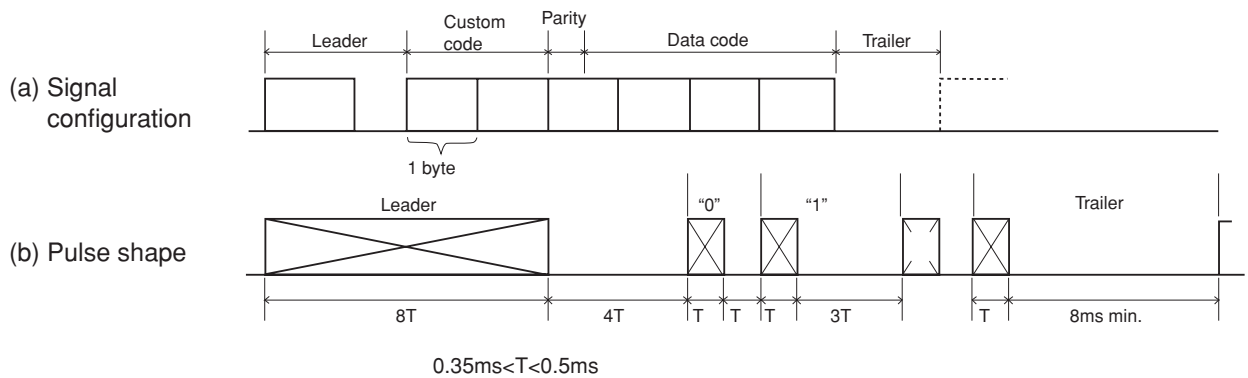

Fig. 10

In this format, the leader is used for the discrimination of the start of transmission, the custom code is registered and used to prevent the remote control and controlled equipment from malfunctioning, and the parity bit along with the custom code is used to confirm that the signal is addressed to the equipment in use. The trailer is used to discriminate the completion of transmission.

With the diffusion of infrared remote control systems for home appliances, certain standards apply to each manufacturer's signal transmission method in the AEHA's format with the method officially registered, thus preventing the remote control and controlled equipment from malfunctioning.

The transmission format presently in use takes individual measures for the prevention of malfunctions. For example, a method is used to transmit the data code three times and read the data code only when the leader code is received correctly at least twice in the three transmissions. Another method is also used to transmit front and back signals and judge the data only after the front and back signals coincide.

5. Precautions for Designing Transmitter Side

1) Transmitter

«Transmitter circuit example»

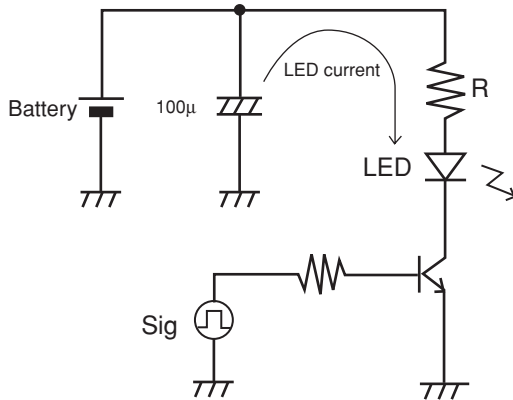

Fig. 13

The resistor R is used to set the forward current of the LED and adjusts the optical output power of the transmitter.

The LED is used usually 5mm in diameter and of high-intensity type.
(Optical wavelength (λ)=940 or 950nm)

The electrolytic capacitor C provides the LED current.

Precautions for Transmission Frequency

Check that the subcarrier frequency of the transmitter coincides with the center frequency of the Remote Control Receiver Module, or otherwise the effective distance may be reduced or no receiving may be possible.

2) Transmission Format

- Leader Pulse

The Remote Control Receiver Module covers a wide input range, and automatically makes receiving sensitivity by using leader pulses. The pulse immediately after the start of input may fluctuate (i.e., the receiving pulse width of output may be wider than the transmission pulse width) if there is no leader pulse.

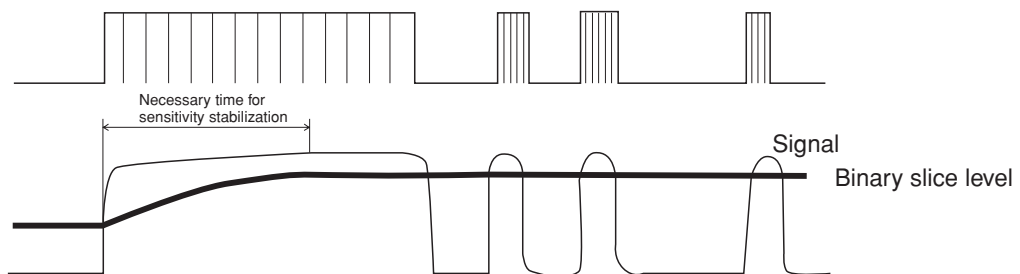
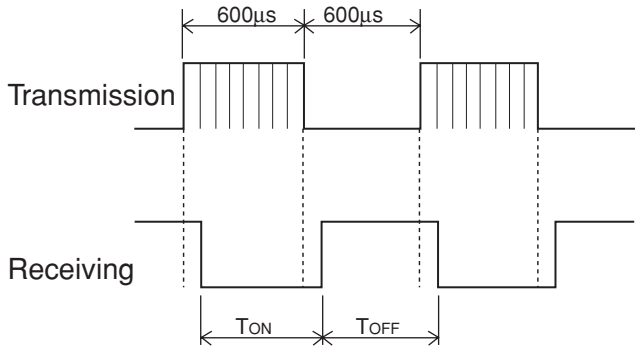

Fig. 14 Automatic Sensitivity Adjustment

• Transmission Pulse Width

Specifications of output pulse width of Remote Control Receiver Module (Transmission pulse width: 600 μ s)



Output pulse width	MIN	TYP	MAX	Unit
T _{ON} /T _{OFF}	400	600	800	μ s

The receiving output pulse fluctuate $\pm 200\mu$ s according to the transmission signal.

Fig. 15

Transmission pulse width (ON/OFF): Both 200 μ s

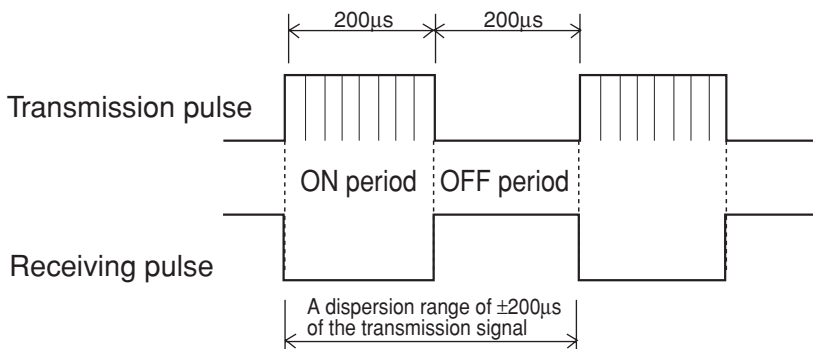

Fig. 16

In the worst case, the dispersion pulse range of output may be 0 to 400 μ s and no receiving may be possible.

• Countermeasure against Dispersion of Receiving Output Pulses

Take the transmission pulse width as wide as possible (for both ON and OFF periods)

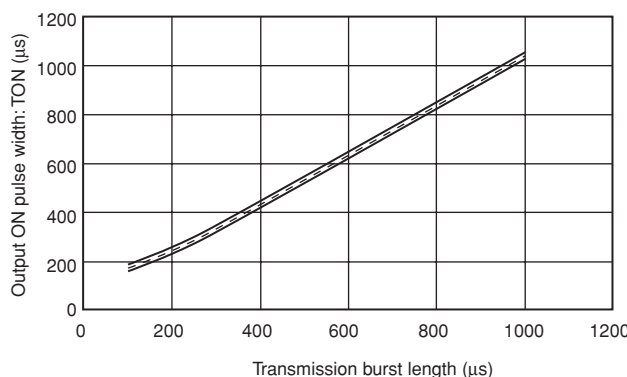
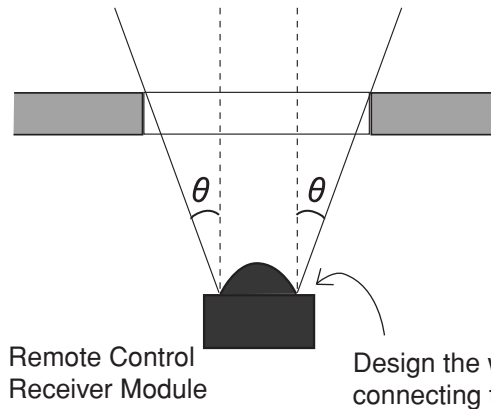

Fig. 17 Output ON Pulse Width vs. Transmission Burst Length of RPM7100-Hx/RPM7200-Hx

6. Precautions for Designing Receiver Side

1) Design of Beam Spread Angle

- Installation of Sensor Window and Remote Control Receiver Module



If the specified beam spread angle is θ_1 , design the sensor window to satisfy the following condition, as shown in the figure on the right-hand side: $\theta > \theta_1$.

If the angle is specified from the lens top, there will be no optical signal incidence at the edge of the lens. Therefore, the Remote Control Receiver Module will not fully demonstrate its performance.

Fig. 18 Sensor Window of RPM7100-Hx/RPM7200-Hx

- Light Guide Tube

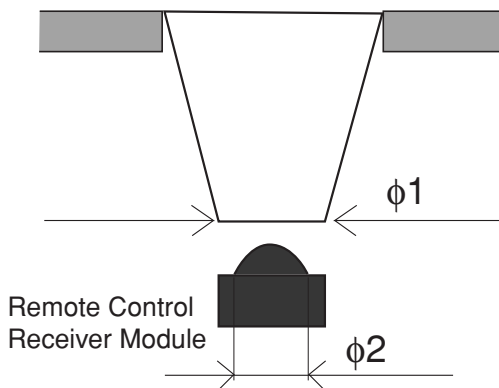

Apply the condition below, on the condition that the diameter of light guide tube on the Remote Control Receiver Module is $\phi 1$ and that of the lens of the Remote Control Receiver is $\phi 2$.

$$\phi 1 > \phi 2$$

The maximum sensitivity is obtained by beaming the optical signal at the whole surface of the lens.

Fig. 19 Light Guide Tube of RPM7100-Hx/RPM7200-Hx

2) Environment-resistive Noise Design

Environments where the Remote Control Receiver Module is used have quantities of noise sources. The Remote Control Receiver Module has very high sensitivity to receive minute optical signals. Therefore, the Remote Control Receiver Module takes a variety of countermeasures against each noise source. If there is an interference of excessive noise, however, the Remote Control Receiver Module may malfunction.

• Various Types of Optical Noise

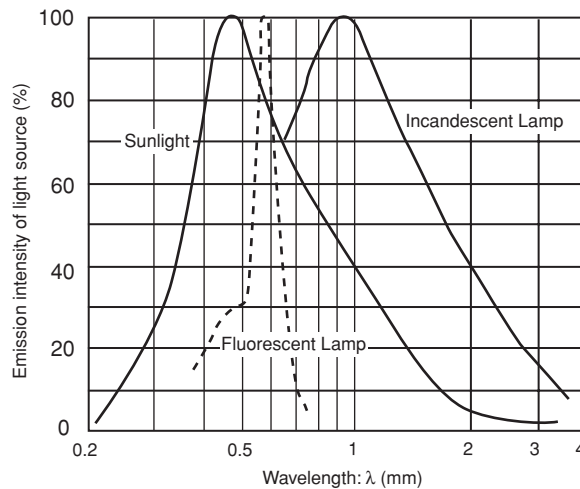

Fig. 20 Optical Noise Wavelength Characteristics

Rapid Fluorescent Lamp

The light emission frequency of a standard fluorescent lamp is 100Hz or 120Hz in most of the countries. It depends on the government policy. Although the light emission frequency is sufficiently lower than the subcarrier frequency of the remote control, the harmonics may cause a malfunction (i.e., a reduction in the effective distance may result).

High Frequency Modulation Type Fluorescent Lamp

In order to reduce the flickering of light, the light emission frequency of an inverter fluorescent lamp is modified. The frequency is around 45kHz, which is close to the subcarrier of the remote controller and becomes noise that cannot be eliminated with ease.

With the incidence of inverter fluorescent light, the effective distance will be shorter in comparison with the case of the rapid fluorescent lamp.

Incandescent Lamp and Sunlight

These light sources have DC noise but including a large quantity of infrared components used for the remote control. The incidence of the noise results in a reduction in effective distance.

• Countermeasures of Set for Optical Noise

Lighting apparatus becomes an optical noise source. In many cases, this noise source is radiated from the upper side. Therefore, at the time of designing the window of the set, limit the incidence of light from the upper side.

• Other Noise Sources

Power Supply Noise

Power supply noise may wrap around from the digital block of the set or may result due to the insufficient smoothing of the power supply circuit. If there are power supply ripples, the effective distance may be reduced. The RPM7100-Hx and RPM7200-Hx Series are designed to reduce the droppage of effective distance to the minimum.

Electromagnetic Noise

The following ones may be sources of electromagnetic noise.

- CRT noise
- LCD (driver) noise (i.e., horizontal synchronizing signal at 38kHz)
- Fluorescent lamp
- Noise radiated from power supply circuit

3) Grounding and Pattern Designing

• Output pull-up resistance

«Circuit diagram»

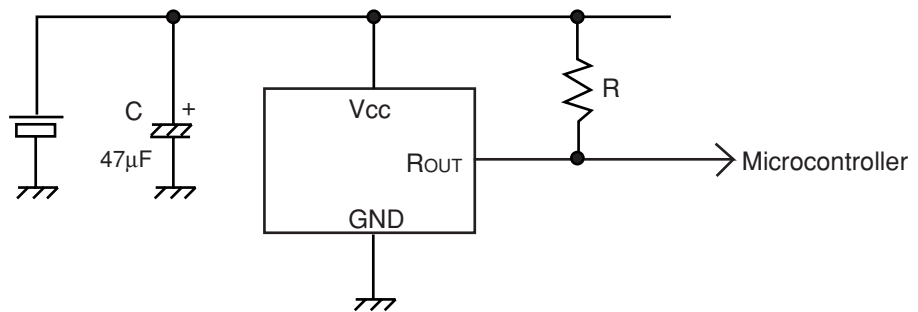

Fig. 21 Pull-up Circuit Diagram

The pull-up resistance connected to the output must limit the absorption current of Remote Control Receiving Module to a range not exceeding a specified value, or otherwise the low-level voltage will be in excess of the specified value.

$$R > \frac{V_{cc} - V_{OL}}{I_{sink}}$$

Isink: Specified Absorption Current Max.	
Model	Isink (µA)
RPM7100-Hx Series	400
RPM7200-Hx Series	200

• Holder Grounding

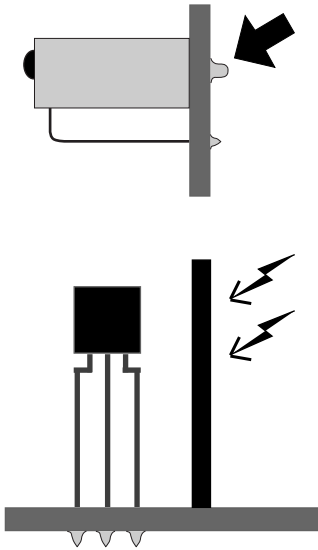

Fig. 22 Shield

Be sure to connect the holder to the ground pattern.

The Remote Control Receiver Module is highly sensitive. In order to protect the influence of external noise, ground the casing.

RPM7100-Hx Series Holderless Model

The installation of a grounded metal shield in the direction of external noise is effective to avoid the influence of the external noise.

• Vcc and Ground Pattern Designing

The Remote Control Receiver Module is highly sensitive in order to receive an infrared signal that is far away. Although a sufficient countermeasure against power ripples is taken, the user should take a further countermeasure in preparation for unforeseen malfunctions.

«Good example»

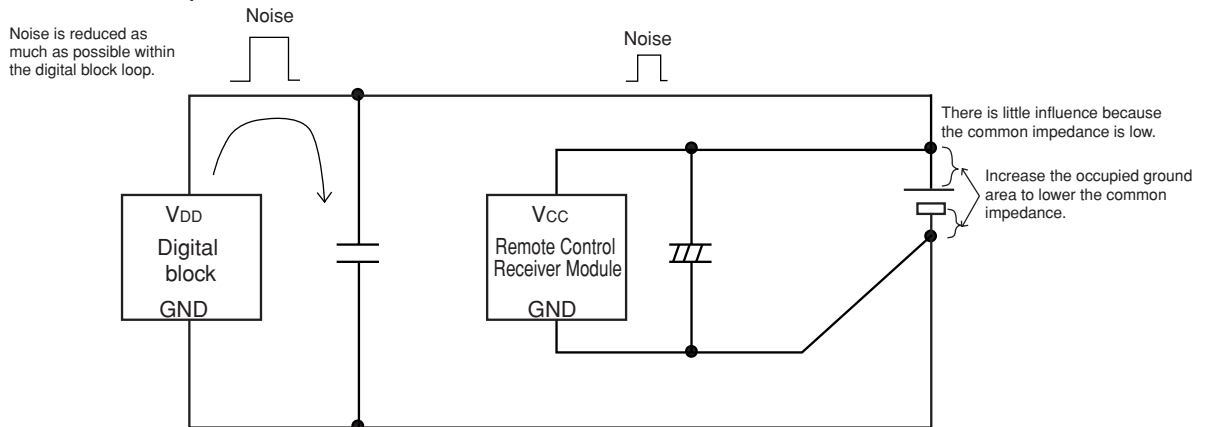

Fig. 23 Countermeasure against Line Noise

«Bad Example»

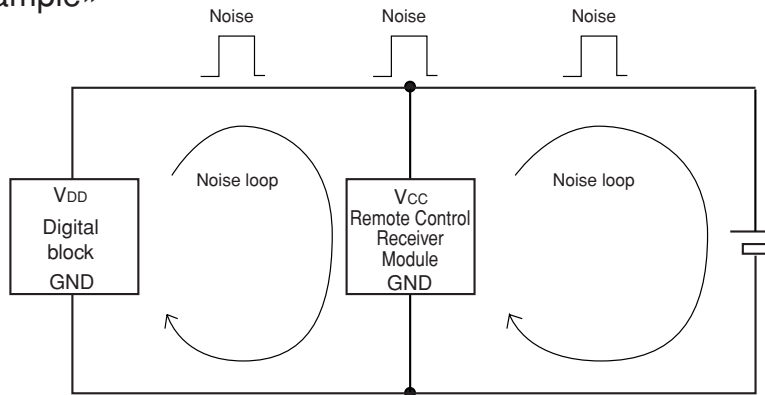

Fig. 24 Countermeasures against Line Noise (Not Good)

In the above wiring pattern, the power noise of the digital block has an adverse influence on the power supply pattern of the Remote Control Receiver Module.

7. Receiving Discrimination Method to Expand Effective Distance

1) Wide Pulse Width Jitter

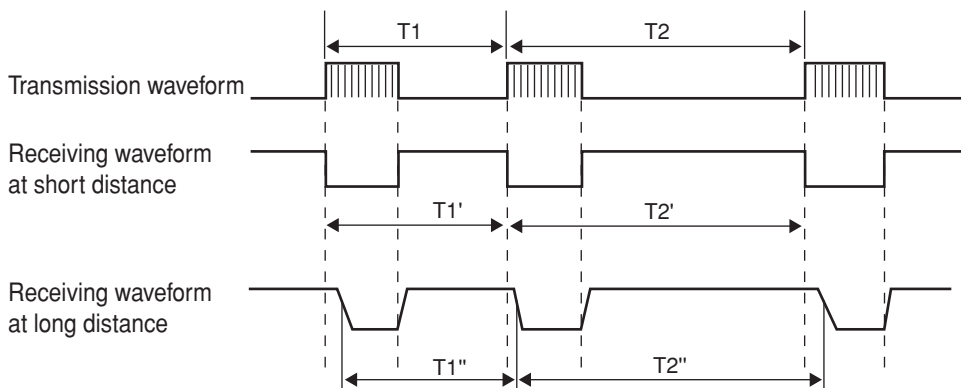

Fig. 25 Jitter Countermeasures

If the communications distance is long or angled or has the incidence of optical noise, the output pulse jitters will become larger at the limit of receiving, thus increasing the errors of the pulse intervals T_1 and T_2 . In order to correct the errors, T_1'' and T_2'' are provided with margins according to the software discrimination of receiving, thus making it possible to increase the effective distance.

2) Pulse Split

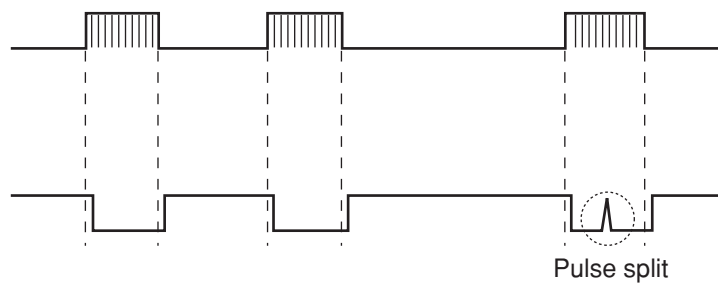

Fig. 26 ON Pulse Split

Incidence of excessive external noise



A pulse split may be caused by external noise, such as optical noise or electromagnetic noise.

If a pulse is split midway, write a receiving discriminative program to ignore the split pulse so that a sufficient effective distance will be secured.

8. Measures for Preventing Malfunctions

If there is strong external noise (e.g., optical noise, electromagnetic noise, or power supply ripples), noise pulses may be generated from the output terminal regardless of whether the input signal exists or not.

1) Receiving Code Discrimination

By always discriminating the receiving of a number of bits in combination as a code, the malfunctioning of the unit can be prevented.

In the above case, it is ideal to use the lead pulse and the code.

2) Falling Edge Discrimination of Single Pulse

Noise pulses may be generated in the output due to the influence of external noise. Therefore, the discrimination of receiving with a non-coded signal (e.g., the falling edge of a single pulse only) is not recommendable.

«Bad Example»

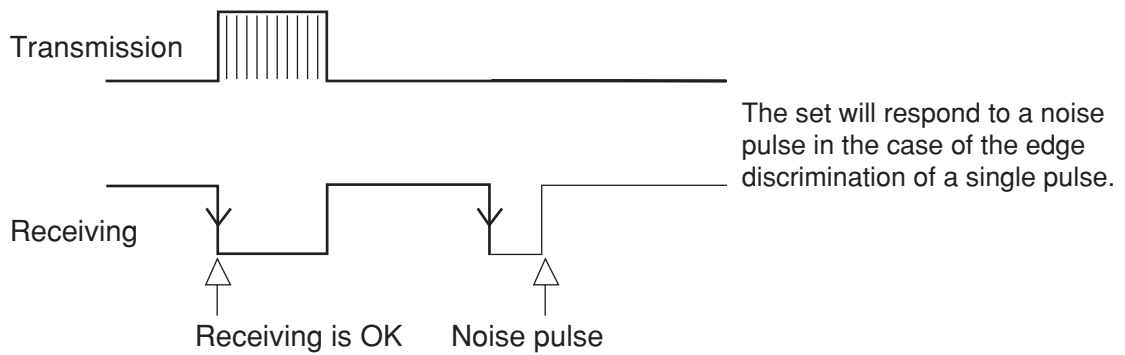

The noise cannot be discriminated from the signal.

Fig. 27 Single Transmission Pulse

3) Subcarrier

- Coincidence of Subcarrier

Make sure that the subcarrier coincides with the center frequency of the Remote Control Receiver Module, or otherwise the effective distance may be shorter or the Remote Control Receiver Module may fail to receive the signal.

- Constant Duty of Subcarrier

Make sure that the duty of the subcarrier is constant. The discontinuance of the duty may cause a receiving output pulse split and result in a receiving error.

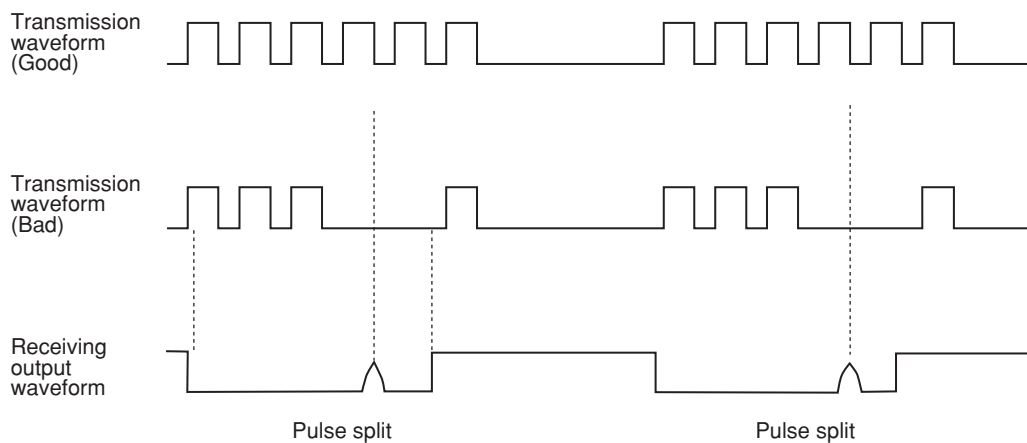

Fig. 28 Duty Discontinuance Period

IrDA Infrared Communication Module



IrDA Infrared Communication Module

■ Contents

IrDA Infrared Communication Module Selection Guide	25
RPM870-H7/RPM870-H12	27
RPM871/RPM871-H7/RPM871-H12	29
RPM872/RPM872-H7/RPM872-H12	31
RPM873	33
RPM882-H7/RPM882-H12	35
RPM960-H14	37
RPM970-H14	39

■ IrDA Infrared Communication Module Selection Guide

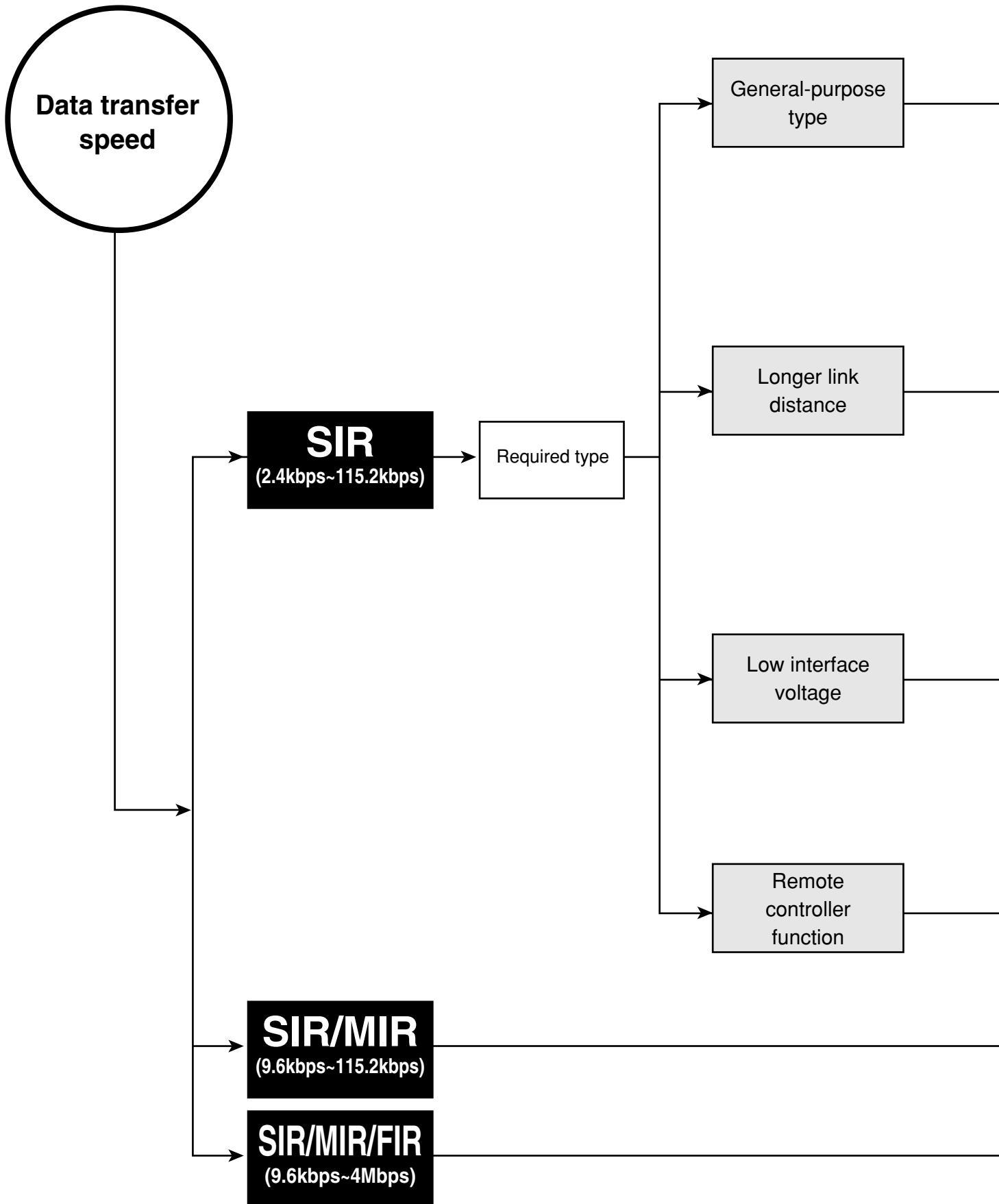

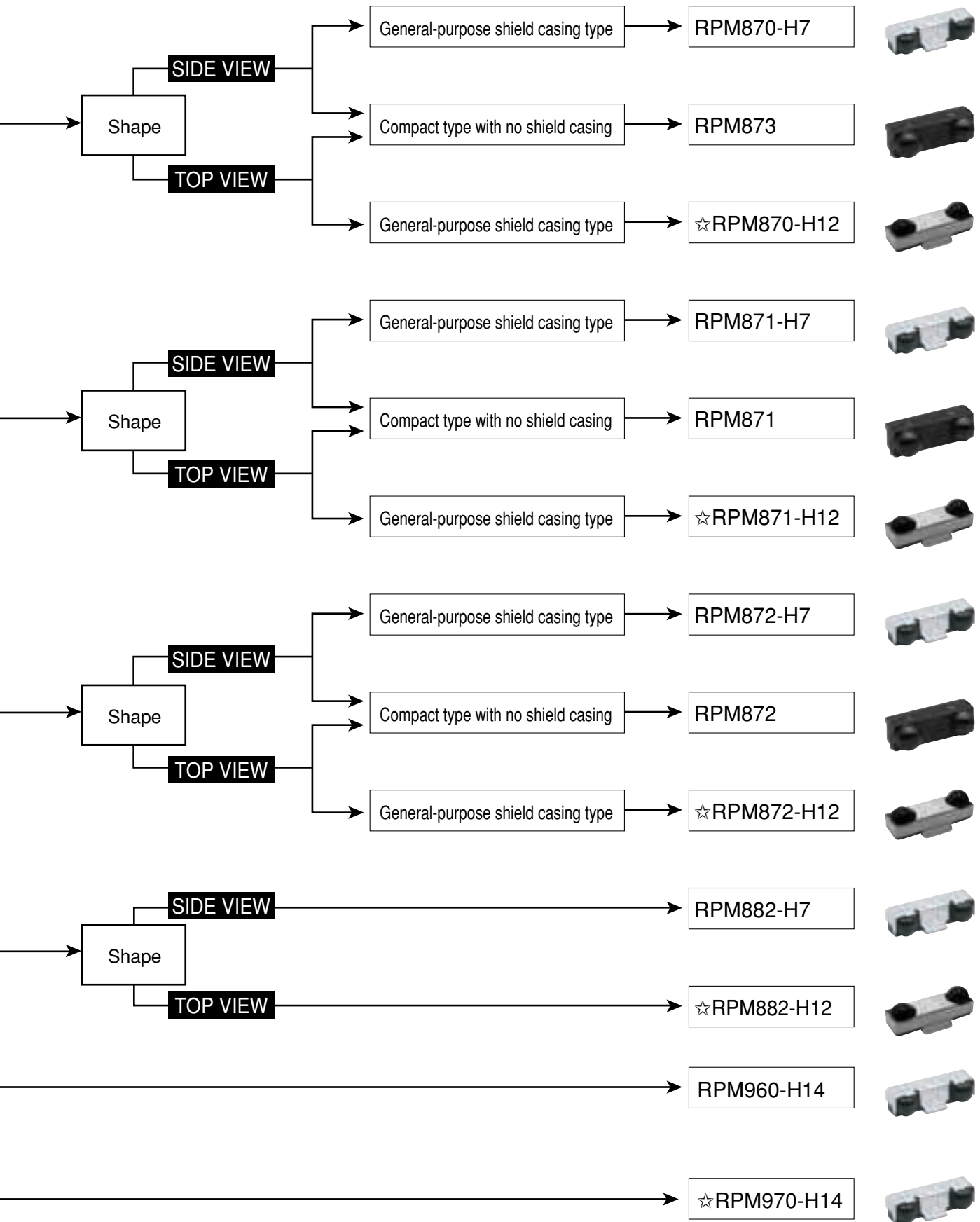

IrDA Infrared Communication Module

☆: Under development

■RPM870-H7/☆RPM870-H12

IrDA Infrared Communication Module IrDA SIR (Low Power)

●Overview

The RPM870 Series is a module that corresponds to IrDA SIR (Low Power) standard. An infrared LED, PIN photodiode, and LSI are all contained in a single subminiature package. This module is designed for low power consumption while in waiting mode. Furthermore, it incorporates a power-down function, thus making the module perfect for mobile sets.

●Features

- 1) Applied to IrDA SIR (low power).
- 2) Low power consumption while in waiting mode (75 μ A typical).
- 3) Incorporates a power-down function that is ideal for battery-powered applications.
- 4) Supports a wide voltage range of power supply from 2.6 to 3.6V.

●Applications

Mobile phone, PDA, digital still camera, POS, and printer

●Absolute Maximum Ratings

Parameter	Symbol	Limits	Unit
Supply Voltage	Vcc	-0.3~+7.0	V
Power Dissipation	Pd	150*1	mW
Operating Temperature Range	Topr	-20~+85	°C
Storage Temperature Range	Tstg	-30~+100	°C

*1. 70mm × 70mm, t=1.6mm, glass epoxy mounting.

Derating: 2mW/°C for operation above Ta=25°C

*2. LED peak current<90 μ s. ON duty<20%

●Recommended Operating Conditions

Parameter	Symbol	Min.	Typ.	Max.	Unit
Supply Voltage	Vcc	2.6	3.0	3.6	V
	V _{LEDA}	2.6	3.0	5.5	V

●Electrical and Optical Characteristics (Ta=25°C, Vcc=V_{LEDA}=3.0V unless otherwise specified)

Parameter	Symbol	Min.	Typ.	Max.	Unit	Conditions
Current Consumption 1	Icc1	—	75	99	μ A	In waiting mode at no input light
Current Consumption 2	Icc2	—	0.01	0.2	μ A	In power down mode at no input light
Transmission Rate		2.4	—	115.2	kbps	
Intensity	IE	4.0	10	26	mW/sr	-15deg. \leq θ_L \leq +15deg.
LED Current	I _{LED}	—	30.5	—	mA	
Half Angle (Emitter)	$\theta_L/2$	—	± 18	—	deg.	
Max. Emitting Pulse Width	TLEDmax	10	48	120	μ sec.	
Maximum Irradiance in Angular	Ee max.	500	—	—	mW/cm ²	-15deg. \leq θ_L \leq +15deg.
Minimum Irradiance in Angular	Ee min.	—	3.6	6.8	μ W/cm ²	-15deg. \leq θ_L \leq +15deg.
Half Angle (Detector)	$\theta_D/2$	± 15	—	—	deg.	
RXD Output Pulse Width	tWRXD	1.5	2.3	4.2	μ sec.	C _L =15pF, 2.4~115.2kbps
Latency	tRT	—	100	200	μ sec.	

●Block Diagram

• RPM870-H7/RPM870-H12

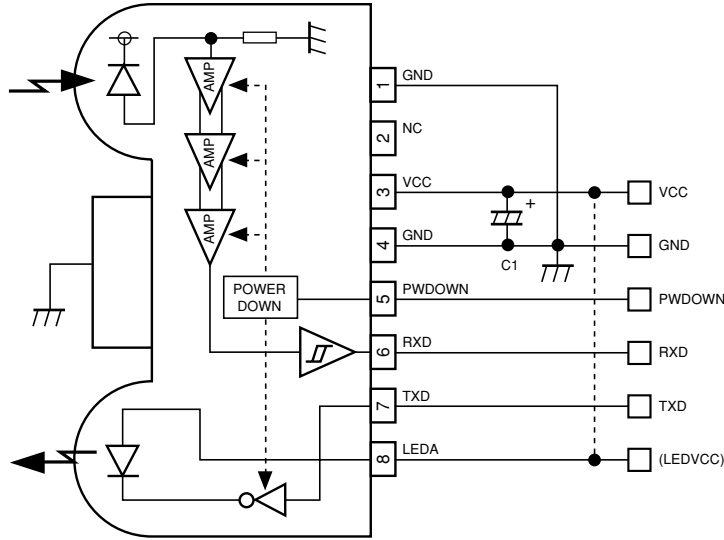

●External Dimensions (Unit: mm)

• RSLP8 (H7)

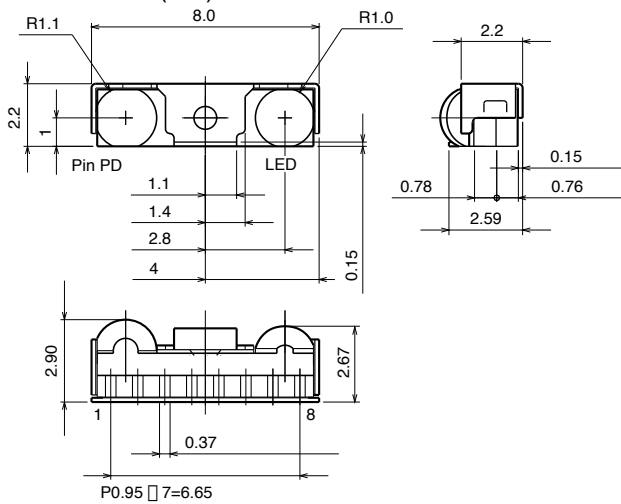

• RSLP8 (H12)

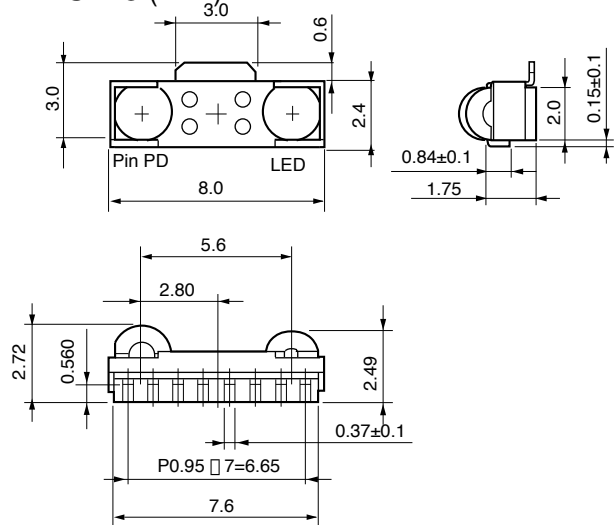

■RPM871/RPM871-H7/☆RPM871-H12

☆: Under development

IrDA Infrared Communication Module IrDA SIR (Low Power)

●Overview

The RPM871 Series is a module that corresponds to IrDA SIR (Low Power) standard. An infrared LED, PIN photodiode, and LSI are all contained in a single subminiature package. This module is designed for low power consumption while in waiting mode. Furthermore, it incorporates a power-down function, thus making the module perfect for mobile sets.

●Features

- 1) Applied to IrDA SIR (low power).
- 2) Low power consumption while in waiting mode (73 μ A typical).
- 3) Incorporates a power-down function that is ideal for battery-powered applications.
- 4) Supports a wide voltage range of power supply from 2.6 to 3.6V.
- 5) The LED intensity is adjustable with an external resistor.

●Applications

Mobile phone, PDA, digital still camera, POS, and printer

●Absolute Maximum Ratings

Parameter	Symbol	Limits	Unit
Supply Voltage	V _{cc}	-0.3~+7.0	V
Power Dissipation	P _d	150*1	mW
Operating Temperature Range	T _{opr}	-20~+85	°C
Storage Temperature Range	T _{stg}	-30~+100	°C
LED Peak Current	I _{fp}	200*2	mA

*1. 70mm × 70mm, t=1.6mm, glass epoxy mounting.

Derating: 2mW/°C for operation above Ta=25°C

*2. LED peak current<90 μ s. ON duty<20%

●Recommended Operating Conditions

Parameter	Symbol	Min.	Typ.	Max.	Unit
Supply Voltage	V _{cc}	2.6	2.8	3.6	V
	V _{LEDA}	2.6	2.8	5.5	V

●Electrical and Optical Characteristics (Ta=25°C, V_{cc}=V_{LEDA}=2.8V unless otherwise specified)

Parameter	Symbol	Min.	Typ.	Max.	Unit	Conditions
Current Consumption 1	I _{cc1}	—	73	99	μ A	In waiting mode at no input light
Current Consumption 2	I _{cc2}	—	0.01	0.2	μ A	In power down mode at no input light
Transmission Rate		2.4	—	115.2	kbps	
Intensity	I _E	14.4	36	93.6	mW/sr	-15deg. \leq θ_L \leq +15deg.
LED Current	I _{LED}	—	144	—	mA	R _L =7.5 Ω
Half Angle (Emitter)	$\theta_L/2$	—	± 18	—	deg.	
Max. Emitting Pulse Width	T _{LEDmax}	10	48	120	μ sec.	
Maximum Irradiance in Angular	E _{e max.}	500	—	—	mW/cm ²	-15deg. \leq θ_L \leq +15deg.
Minimum Irradiance in Angular	E _{e min.}	—	3.6	6.8	μ W/cm ²	-15deg. \leq θ_L \leq +15deg.
Half Angle (Detector)	$\theta_D/2$	± 15	—	—	deg.	
RXD Output Pulse Width	t _{WRXD}	1.5	2.3	4.2	μ sec.	C _L =15pF, 2.4~115.2kbps
Latency	t _{RT}	—	100	200	μ sec.	

● Block Diagram

• RPM871

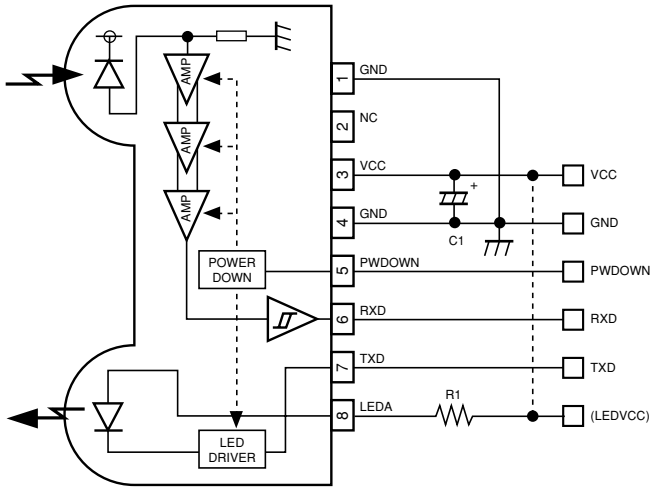

• RPM871-H7/RPM871-H12

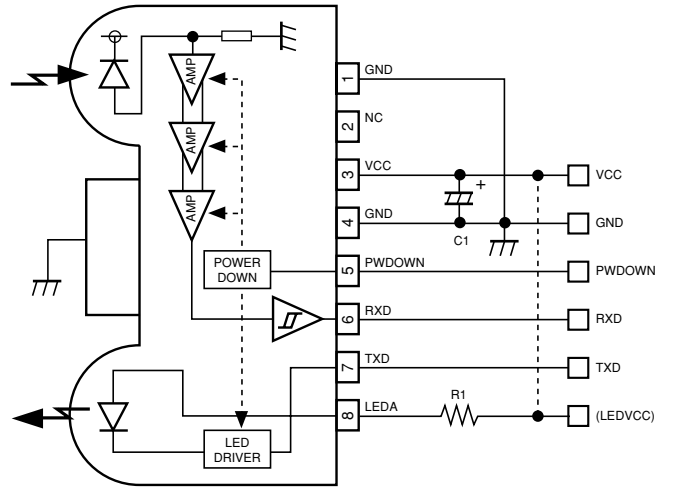

● External Dimensions (Unit: mm)

• RSLP8

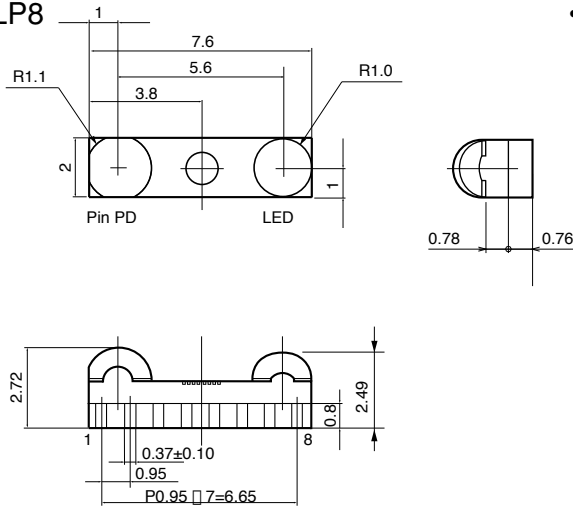

• RSLP8 (H7)

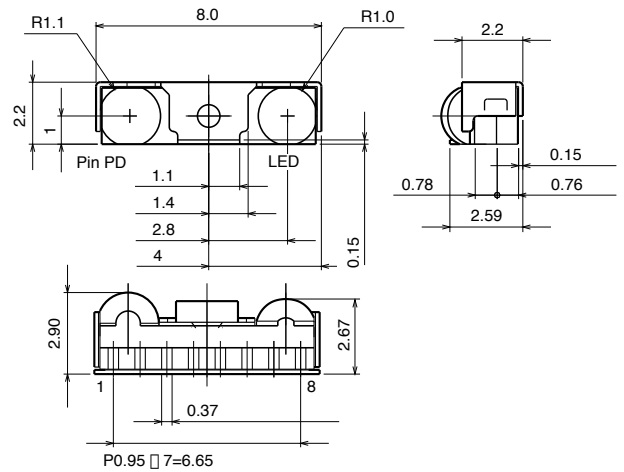

• RSLP8 (H12)

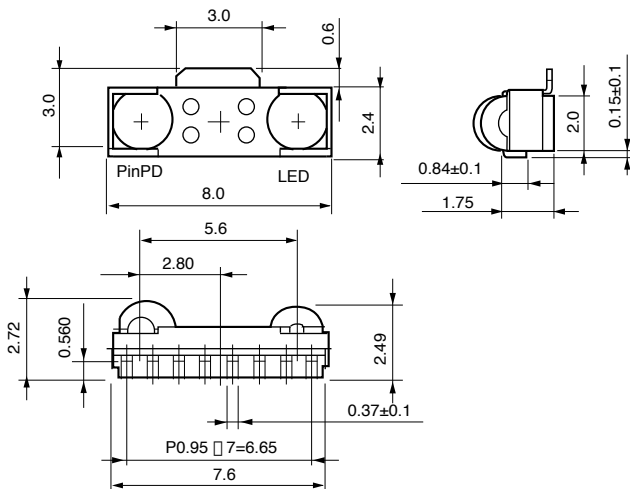

IrDA Infrared Communication Module

■RPM872/RPM872-H7/☆RPM872-H12

IrDA Infrared Communication Module IrDA SIR (Low Power)

●Overview

The RPM872 Series is a module that corresponds to IrDA SIR (Low Power) standard. An infrared LED, PIN photodiode, and LSI are all contained in a single subminiature package. This module is designed for low power consumption while in waiting mode. Furthermore, it incorporates a power-down function, thus making the module perfect for mobile sets.

●Features

- 1) Applied to IrDA SIR (low power).
- 2) Low power consumption while in waiting mode (75 μ A typical).
- 3) Incorporates a power-down function that is ideal for battery-powered applications.
- 4) Supports low-voltage operation.

$$V_{CC}=2.0\sim 3.6V$$

$$V_{IO}=1.5\sim 3.6V$$

$$V_{LED}=2.6\sim 5.5V$$

●Applications

Mobile phone, PDA, digital still camera, POS, and printer

●Absolute Maximum Ratings

Parameter	Symbol	Limits	Unit
Supply Voltage	V _{CC}	-0.3~+7.0	V
Power Dissipation	P _d	150 ^{*1}	mW
Operating Temperature Range	T _{opr}	-20~+85	°C
Storage Temperature Range	T _{stg}	-30~+100	°C

*1. 70mm × 70mm, t=1.6mm, glass epoxy mounting.
Derating: 2mW/°C for operation above T_a=25°C

●Recommended Operating Conditions

Parameter	Symbol	Min.	Typ.	Max.	Unit
Supply Voltage	V _{CC}	2.0	3.0	3.6	V
	V _{LEDA}	2.7	3.0	5.5	V
	V _{IO}	1.5	3.0	V _{CC}	V

●Electrical and Optical Characteristics (T_a=25°C, V_{CC}=V_{LEDA}=3.0V unless otherwise specified)

Parameter	Symbol	Min.	Typ.	Max.	Unit	Conditions
Current Consumption 1	I _{CC1}	—	75	99	μ A	In waiting mode at no input light
Current Consumption 2	I _{CC2}	—	0.01	0.2	μ A	In power down mode at no input light
Transmission Rate		2.4	—	115.2	kbps	
Intensity	I _E	4.0	10	26	mW/sr	-15deg. \leq θ_L \leq +15deg.
LED Current	I _{LED}	—	30.5	—	mA	
Half Angle (Emitter)	$\theta_{L/2}$	—	± 18	—	deg.	
Max. Emitting Pulse Width	T _{LEDmax}	10	48	120	μ sec.	
Maximum Irradiance in Angular	E _{e max.}	500	—	—	mW/cm ²	-15deg. \leq θ_L \leq +15deg.
Minimum Irradiance in Angular	E _{e min.}	—	3.6	6.8	μ W/cm ²	-15deg. \leq θ_L \leq +15deg.
Half Angle (Detector)	$\theta_{D/2}$	± 15	—	—	deg.	
RXD Output Pulse Width	t _{WRXD}	1.5	2.3	4.2	μ sec.	C _L =15pF, 2.4~115.2kbps
Latency	t _{RT}	—	100	200	μ sec.	

●Block Diagram

• RPM872

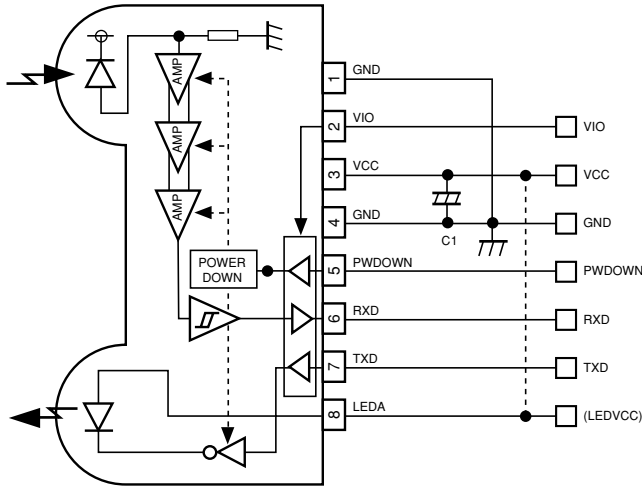

• RPM872-H7/RPM872-H12

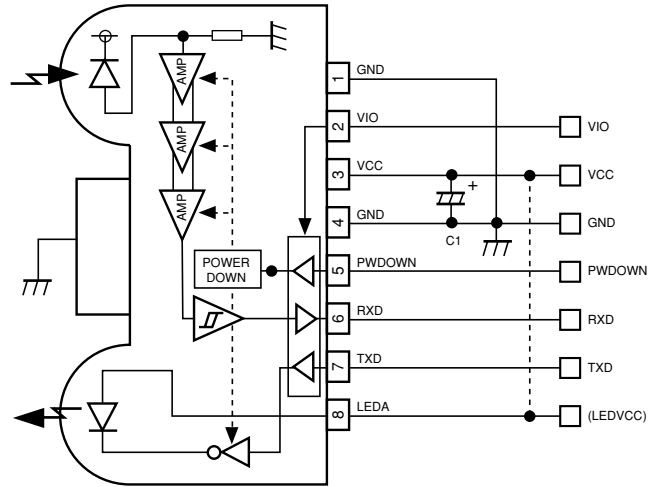

●External Dimensions (Unit: mm)

• RSLP8

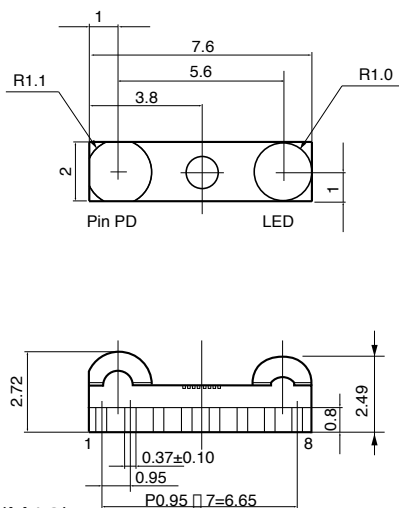

• RSLP8 (H7)

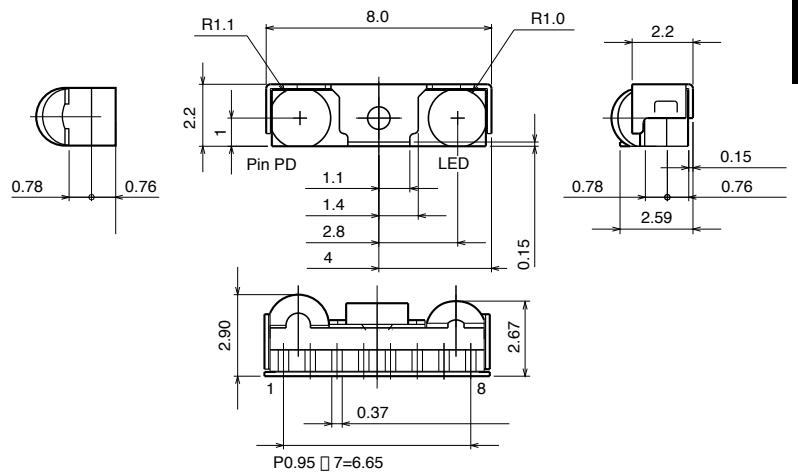

• RSLP8 (H12)

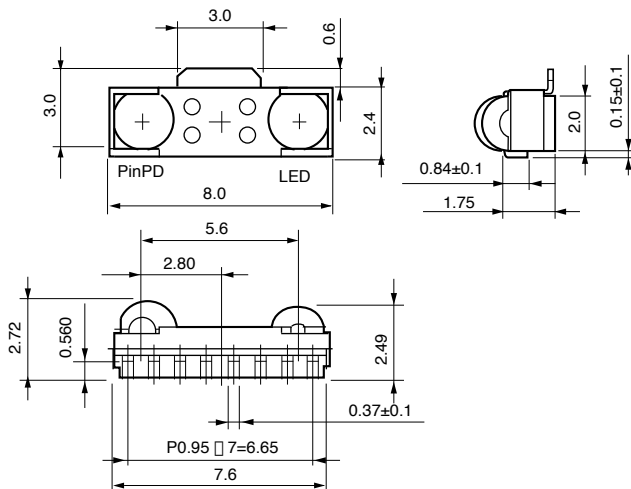

IrDA Infrared Communication Module

■RPM873

IrDA Infrared Communication Module IrDA SIR (Low Power)

●Overview

The RPM873 Series is a module that corresponds to IrDA SIR (Low Power) standard. An infrared LED, PIN photodiode, and LSI are all contained in a single subminiature package. This module is designed for low power consumption while in waiting mode. Furthermore, it incorporates a power-down function, thus making the module perfect for mobile sets.

●Features

- 1) Applied to IrDA SIR (low power).
- 2) Low power consumption while in waiting mode (75 μ A typical).
- 3) Incorporates a power-down function that is ideal for battery-powered applications.
- 4) Supports a wide voltage range of power supply from 2.0 to 3.6V.

●Applications

Mobile phone, PDA, digital still camera, POS, and printer

●Absolute Maximum Ratings

Parameter	Symbol	Limits	Unit
Supply Voltage	V _{cc}	-0.3~+7.0	V
Power Dissipation	P _d	150 ^{*1}	mW
Operating Temperature Range	T _{opr}	-20~+85	°C
Storage Temperature Range	T _{stg}	-30~+100	°C

*1. 70mm × 70mm, t=1.6mm, glass epoxy mounting.

Derating: 2mW/°C for operation above Ta=25°C

*2. LED peak current<90 μ s. ON duty<20%

●Recommended Operating Conditions

Parameter	Symbol	Min.	Typ.	Max.	Unit
Supply Voltage	V _{cc}	2.0	3.0	3.6	V
	V _{LEDA}	2.6	3.0	5.5	V

●Electrical and Optical Characteristics (Ta=25°C, V_{cc}=V_{LEDA}=3.0V unless otherwise specified)

Parameter	Symbol	Min.	Typ.	Max.	Unit	Conditions
Current Consumption 1	I _{cc1}	—	75	99	μ A	In waiting mode at no input light
Current Consumption 2	I _{cc2}	—	0.01	0.2	μ A	In power down mode at no input light
Transmission Rate		2.4	—	115.2	kbps	
Intensity	IE	4.0	10	26	mW/sr	-15deg. \leq θ \leq +15deg.
LED Current	I _{LED}	—	30.5	—	mA	
Half Angle (Emitter)	θ _{L/2}	—	\pm 18	—	deg.	
Max. Emitting Pulse Width	T _{LEDmax}	10	48	120	μ sec.	
Maximum Irradiance in Angular	E _{e max.}	500	—	—	mW/cm ²	-15deg. \leq θ \leq +15deg.
Minimum Irradiance in Angular	E _{e min.}	—	3.6	6.8	μ W/cm ²	-15deg. \leq θ \leq +15deg.
Half Angle (Detector)	θ _{D/2}	\pm 15	—	—	deg.	
RXD Output Pulse Width	t _{WRXD}	1.5	2.3	4.2	μ sec.	C _L =15pF, 2.4~115.2kbps
Latency	t _{RT}	—	100	200	μ sec.	

●Block Diagram

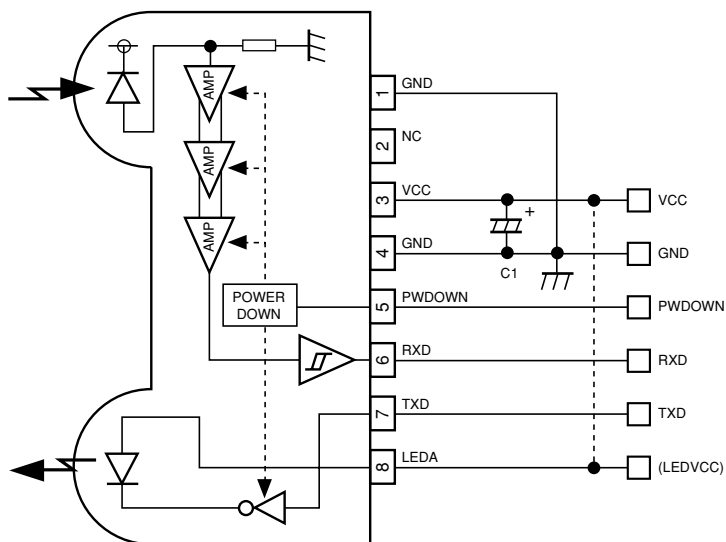

●External Dimensions (Unit: mm)

• RSLP8

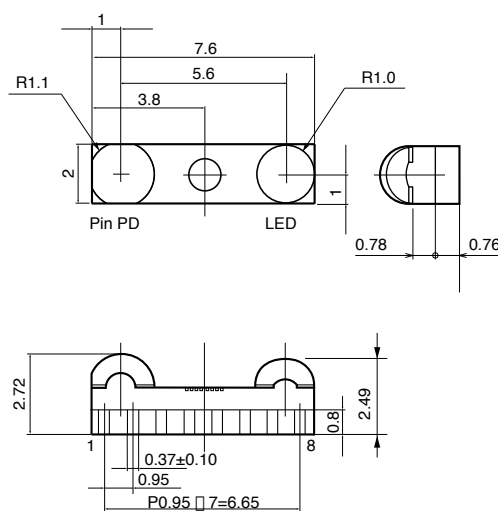

■RPM882-H7/☆RPM882-H12

IrDA Infrared Communication Module IrDA SIR (Low Power) with Remote Control Function

●Features

- 1) Realizes a directional pattern compatible with difference between IrDA and remote control optical axis.
- 2) Ensures a remote control effective distance of approximately 9m (at an ILED of 200mA).
- 3) Compatible with IrDA SIR (Serial Infrared) low power communication.
- 4) Interfacing with the digital block at a minimum voltage of 1.5V.
- 5) A single- or double-input type is selectable as a means of input for IrDA and remote control transmission.

●Applications

Mobile phone and PDA

●Absolute Maximum Ratings (Ta=25°C)

Parameter	Symbol	Limits	Units
Supply Voltage	Vmax	7.0 ^{*1}	V
Input Voltage	Vin (4, 5, 6, 7 pin)	-0.3~VIO+0.3	V
Operation Temperature	Topr	-25~85	°C
Storage Temperature	Tstg	-30~100	°C
LED Peak Current	I _{fp}	300 ^{*2}	mA
Power Dissipation	Pd	300 ^{*3}	mW

*1. This applied to all pins basis ground pins (1 pin)
 *2. LED Peak Current: <90usec, On duty<50%
 *3. When glass-epoxy board (70 × 70 × 1.6mm) mounted. In case operating environment is over 25°C, 4mW would be reduced per each 1°C stepping up.

●Recommended Operating Conditions

Parameter	Symbol	Min.	Typ.	Max.	Units
Supply Voltage	VCC	2.4	3.0	3.6	V
	VIO	1.5	3.0	VCC	V
	LEDVCC	2.6	3.0	5.5	V

●Electrical Characteristics (VCC=VIO=3V, LEDVCC=3V, Ta=25°C unless otherwise specified)

Parameter	Symbol	Min.	Typ.	Max.	Units	Condition
Consumption Current 1	I _{cc1}	—	80	104	μA	PWDOWN=0V, No incidence
Consumption Current 2	I _{cc2}	—	0.01	0.2	μA	PWDOWN=VIO, No incidence
LED Anode Current (IrDA Mode)	I _{LEDA1}	28	40	52	mA	TXD=VIO, R1=4.7Ω, PWDOWN=0V
LED Anode Current (RC Mode)	I _{LEDA2}	150	200	245	mA	TX-RC=VIO, R1=4.7Ω, PWDOWN=0V
RXD Output Pulse Width	tw _{RXD}	1.5	2.3	4.2	μs	C _L =15pF, 2.4~115.2kbps

●Optical Characteristics (VCC=VIO=3V, LEDVCC=3V, Ta=25°C unless otherwise specified)

Parameter	Symbol	Min.	Typ.	Max.	Units	Condition
Peak Wave Length 1 (IrDA Mode)	λ _{P1}	850	—	900	nm	I _{LED} =50mA, Duty 20%
Peak Wave Length 2 (RC Mode)	λ _{P2}	880	890	920	nm	I _{LED} =200mA, Duty 20%
Intensity 1 (IrDA Mode)	I _{E1}	4	13	28	mW/sr	-15deg. ≤ θ _L ≤ 15deg., R1=4.7Ω
Intensity 2 (RC Mode)	I _{E2}	30	65	130	mW/sr	-15deg. ≤ θ _L ≤ 15deg., R1=4.7Ω
Half Angle (Emitter)	θ _{L/2}	±15	±22	—	deg	
Minimum Irradiance in Angular	E _{e min.}	—	3.6	6.8	μW/cm ²	-15deg. ≤ θ _L ≤ 15deg.
Maximum Irradiance in Angular	E _{e max.}	500	—	—	mW/cm ²	-15deg. ≤ θ _L ≤ 15deg.
Half-Angule (Detector)	θ _{D/2}	±15	—	—	deg	
Maximum Emitting Time	T _{LEDmax}	20.5	48	120	μs	TXD=0 → VIO or TX-RC=0 → at VIO

●Block Diagram

• RPM882-H7/RPM882-H12

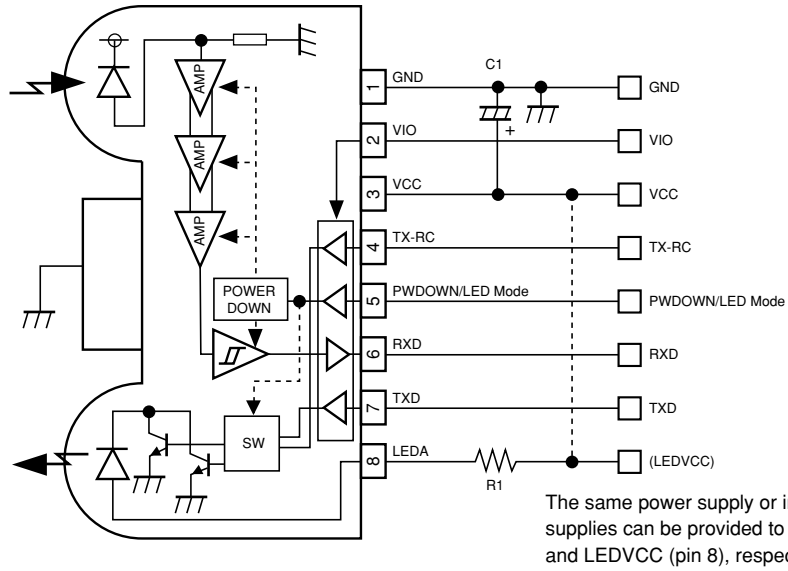

IrDA Infrared Communication Module

●External Dimensions (Unit: mm)

• RSLP8 (H7)

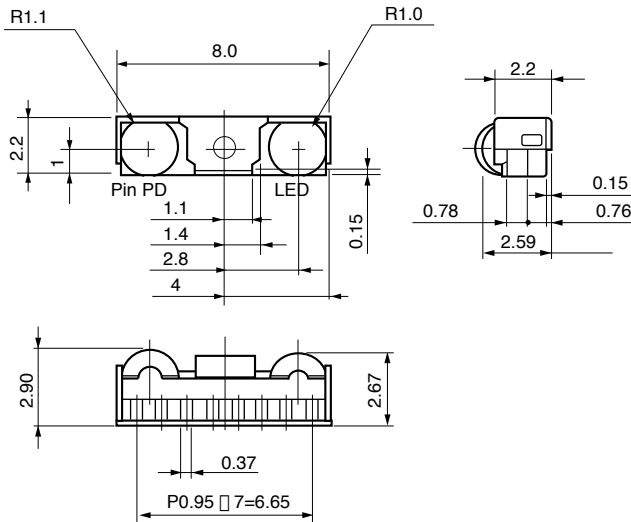

• RSLP8 (H12)

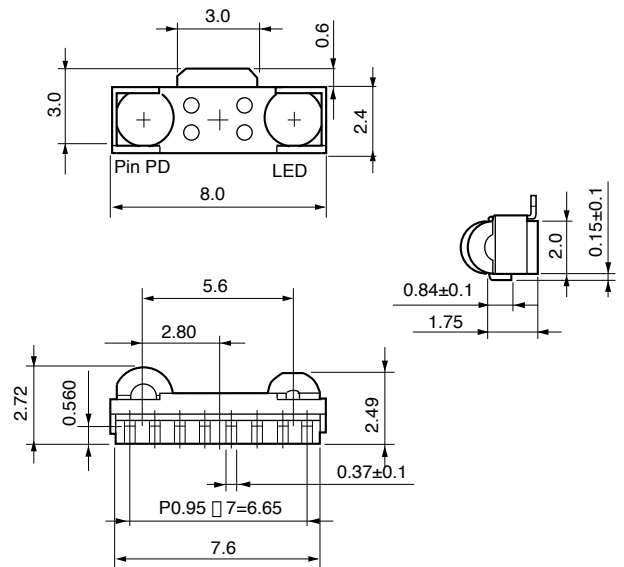

■RPM960-H14

IrDA Infrared Communication Module IrDA SIR/MIR (Low Power)

●Overview

The RPM960-H14 Series is a module that corresponds to IrDA (Low Power) standard. An infrared LED, PIN photodiode, and LSI are all contained in a single subminiature package. This module is designed for low power consumption while in waiting mode. Furthermore, it incorporates a power-down function, thus making the module perfect for mobile sets.

●Features

- 1) Applied to IrDA SIR/MIR (low power).
- 2) Low power consumption while in waiting mode (440 μ A typical).
- 3) Incorporates a power-down function that is ideal for battery-powered applications.
- 4) Supports a wide voltage range of power supply from 2.4~3.6V.
- 5) The communications distance is changeable within an approximate rate between 20 and 50cm with the selection of LED load resistance.

●Applications

Mobile phone, PDA, digital still camera, POS, and printer

●Absolute Maximum Ratings

Parameter	Symbol	Limits	Unit
Supply Voltage	Vcc	-0.3~+6.5	V
Power Dissipation	Pd	300 ^{*1}	mW
Operating Temperature Range	Topr	-25~+85	°C
Storage Temperature Range	Tstg	-30~+100	°C
LED Peak Current	I _{fp}	400 ^{*2}	mA

*1. 70mm × 70mm, t=1.6mm, glass epoxy mounting.

Derating: 2 mW/°C for operation above Ta=25°C

*2. LED peak current<90 μ s. ON duty<20%

●Recommended Operating Conditions

Parameter	Symbol	Min.	Typ.	Max.	Unit
Supply voltage	Vcc	2.4	3.0	3.6	V
	V _{LEDA}	2.7	3.0	5.5	V
	V _{io}	1.8	3.0	Vcc	V

●Electrical and Optical Characteristics (Ta=25°C, Vcc=V_{LEDA}=3.0V unless otherwise specified)

Parameter	Symbol	Min.	Typ.	Max.	Unit	Conditions
Current Consumption 1	I _{cc1}	—	440	610	μ A	In waiting mode at no input light
Current Consumption 2	I _{cc2}	—	0.01	0.2	μ A	In power down mode at no input light
Transmission Rate		2.4	—	1152	kbps	
Intensity	IE	25	63	200	mW/sr	R1=5.6 Ω , -15deg. \leq θ \leq +15deg.
LED Current	I _{LED}	—	170	—	mA	R1=5.6 Ω
Half Angle (Emitter)	θ L/2	—	\pm 18	—	deg.	
Max. Emitting Pulse Width	T _{LEDmax}	10	48	120	μ sec.	
Maximum Irradiance in Angular	E _{e max.}	500	—	—	mW/cm ²	-15deg. \leq θ \leq +15deg.
Minimum Irradiance in Angular	E _{e min.}	—	9	14	μ W/cm ²	-15deg. \leq θ \leq +15deg.
Half Angle (Detector)	θ D/2	\pm 15	—	—	deg.	
RXD Output Pulse Width	t _{WRXD}	228	380	400	nsec.	C _L =15pF, 2.4~1152kbps
Latency	t _{RT}	—	100	200	μ sec.	

●Block Diagram

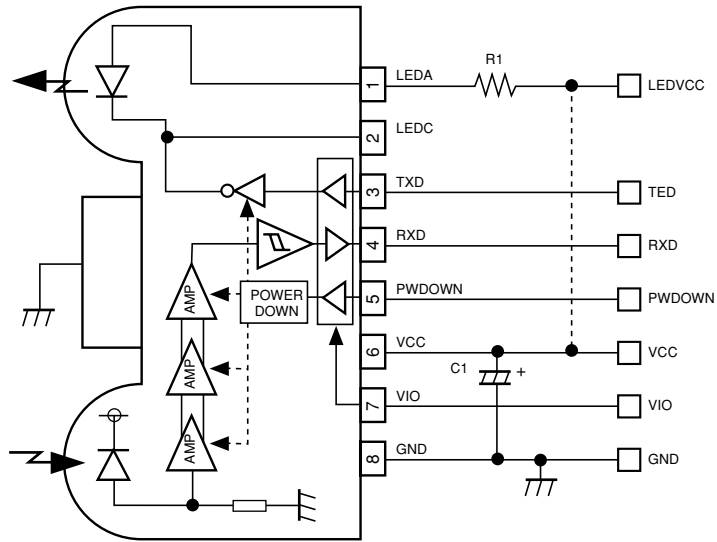

IrDA Infrared Communication Module

●External Dimensions (Unit: mm)

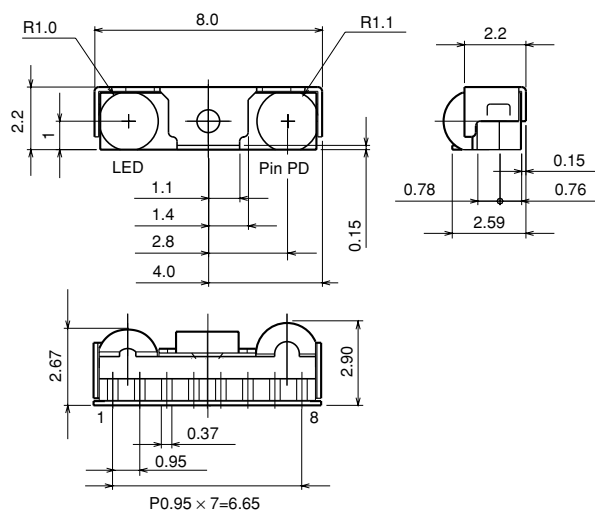

★RPM970-H14

IrDA Infrared Communication Module IrDA SIR/MIR/FIR (Low Power)

●Overview

The RPM970-H14 Series is a module that corresponds to IrDA SIR/MIR/FIR (Low Power) standard. An infrared LED, PIN photodiode, and LSI are all contained in a single subminiature package. This module is designed for low power consumption while in waiting mode. Furthermore, it incorporates a power-down function, thus making the module perfect for mobile sets.

●Features

- 1) Applied to IrDA SIR/MIR/FIR (low power).
- 2) Low power consumption while in waiting mode (800 μ A typical).
- 3) Incorporates a power-down function that is ideal for battery-powered applications.
- 4) Supports a wide voltage range of power supply from 2.4 to 3.6V.
- 5) The communications distance is changeable within an approximate rate between 20 and 50cm with the selection of LED load resistance.

●Applications

Mobile phone, PDA, digital still camera, POS, and printer

●Absolute Maximum Ratings

Parameter	Symbol	Limits	Unit
Supply Voltage	Vcc	-0.3 ~+6.5	V
Power Dissipation	Pd	300 ⁻¹	mW
Operating Temperature Range	Topr	-25~+85	°C
Storage Temperature Range	Tstg	-30~+100	°C
LED Peak Current	Ifp	400 ⁻²	mA

*1. 70mm × 70mm, t=1.6mm, glass epoxy mounting.

Derating: 2mW/°C for operation above Ta=25°C

*2. LED peak current<90 μ s. ON duty<20%

●Recommended Operating Conditions

Parameter	Symbol	Min.	Typ.	Max.	Unit
Supply Voltage	Vcc	2.4	3.0	3.6	V
	VLEDA	2.7	3.0	5.5	V
	Vio	1.7	3.0	Vcc	V

●Electrical and Optical Characteristics (Ta=25°C, Vcc=V_{LEDA}=3.0V unless otherwise specified)

Parameter	Symbol	Min.	Typ.	Max.	Unit	Conditions
Current Consumption 1	Icc1	—	800	1200	μ A	In waiting mode at no input light
Current Consumption 2	Icc2	—	0.01	0.2	μ A	In power down mode at no input light
Transmission Rate		9.6	—	4000	kbps	
Intensity	IE	25	63	200	mW/sr	R1=5.6 Ω , -15deg. $\leq\theta_L\leq$ +15deg.
LED Current	I _{LED}	—	170	—	mA	R1=5.6 Ω
Half Angle (Emitter)	$\theta_{L/2}$	—	± 18	—	deg.	
Max. Emitting Pulse Width	TLEDmax	16	48	120	μ sec.	TXD=VIO
Maximum Irradiance in Angular	Ee max.	500	—	—	mW/cm ²	-15deg. $\leq\theta_L\leq$ +15deg.
Minimum Irradiance in Angular	Ee min.	—	9	20	μ W/cm ²	-15deg. $\leq\theta_L\leq$ +15deg.
Half Angle (Detector)	$\theta_{D/2}$	± 15	—	—	deg.	
RXD Output Pulse Width (SIR/MIR)	tWRXDS	228	380	532	nsec.	C _L =15pF, 9.6~1152kbps
RXD Output Pulse Width (FIR)	tWRXDF1	85	125	165	nsec.	C _L =15pF, 4Mbps (125ns pulse)
RXD Output Pulse Width (FIR)	tWRXDF2	195	250	290	nsec.	C _L =15pF, 4Mbps (250ns pulse)
Latency	tRT	—	100	200	μ sec.	

●Block Diagram

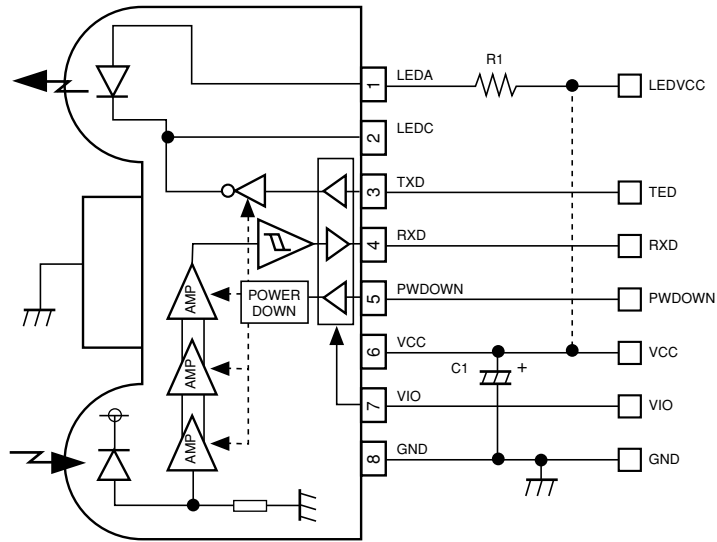

IrDA Infrared Communication Module

●External Dimensions (Unit: mm)

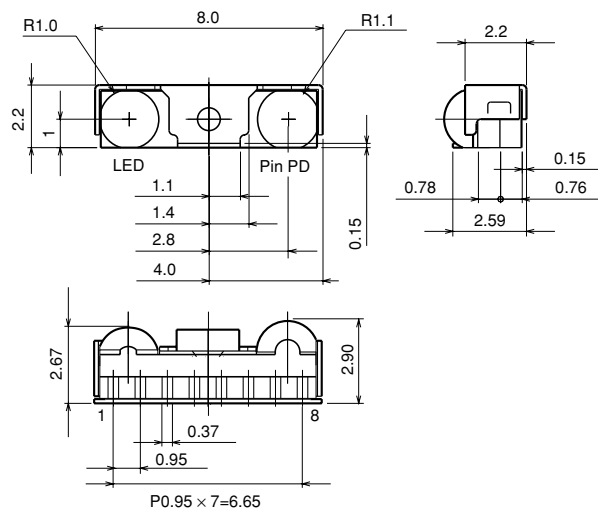

- The contents described herein are correct as of
- ROHM assumes no responsibility for the use of any circuits described herein, conveys no license under any patent or other right, and makes no representations that the circuits are free from patent infringement. Specifications subject to change without notice for the purpose of improvement.

The products listed in this catalog are designed to be used with ordinary electronic equipment or devices (such as audio visual equipment, office-automation equipment, communications devices, electrical appliances and electronic toys). Should you intend to use these products with equipment or devices which require an extremely high level of reliability and the malfunction of which would directly endanger human life (such as medical instruments, transportation equipment, aerospace machinery, nuclear-reactor controllers, fuel controllers and other safety devices), please be sure to consult with our sales representative in advance.

Excellence in Electronics



ROHM CO., LTD.

21, Saiin Mizosaki-cho, Ukyo-ku, Kyoto
615-8585, Japan
TEL: (075)311-2121 FAX: (075)315-0172
URL <http://www.rohm.com>

Contact us for further information about the products.

Atlanta U.S.A. / ROHM ELECTRONICS EASTERN SALES DIVISION
(DIVISION OF ROHM ELE.U.S.A.,LLC)
TEL: +1(770)754-5972 FAX: +1(770)754-0691

Dallas U.S.A. / ROHM ELECTRONICS CENTRAL SALES DIVISION
(DIVISION OF ROHM ELE.U.S.A.,LLC)
TEL: +1(972)312-8818 FAX: +1(972)312-0330

San Diego U.S.A. / ROHM ELECTRONICS WESTERN SALES DIVISION
(DIVISION OF ROHM ELE.U.S.A.,LLC)
TEL: +1(858)625-3630 FAX: +1(858)625-3670

Germany / ROHM ELECTRONICS GERMANY SALES DIVISION
(DIVISION OF ROHM ELECTRONICS GMBH)
TEL: +49(2154)9210 FAX: +49(2154)921400

United Kingdom / ROHM ELECTRONICS UK SALES DIVISION
(DIVISION OF ROHM ELECTRONICS GMBH)
TEL: +44(1)908-282-666 FAX: +44(1)908-282-528

France / ROHM ELECTRONICS FRANCE SALES DIVISION
(DIVISION OF ROHM ELECTRONICS GMBH)
TEL: +33(1)41 23 14 00 FAX: +33(1)41 23 14 30

Hong Kong China / ROHM ELECTRONICS (H.K.) CO., LTD.
TEL: +852(2)7406262 FAX: +852(2)3758971

Shanghai China / ROHM ELECTRONICS (SHANGHAI) CO., LTD.
TEL: +86(21)6279-2727 FAX: +86(21)6247-2066

Dalian China / ROHM ELECTRONICS TRADING (DALIAN) CO., LTD.
TEL: +86(41)1230-8549 FAX: +86(41)1230-8537

Beijing China / BEIJING REPRESENTATIVE OFFICE
TEL: +86(10)8451-2426 FAX: +86(10)6460-9518

Taiwan / ROHM ELECTRONICS TAIWAN CO., LTD.
TEL: +886(2)2500-6956 FAX: +886(2)2503-2869

Korea / ROHM ELECTRONICS KOREA CORPORATION
TEL: +82(2)8182-700 FAX: +82(2)8182-715

Singapore / ROHM ELECTRONICS ASIA PTE.LTD. (RES/REI)
TEL: +65-332-2322 FAX: +65-332-5662

Malaysia / ROHM ELECTRONICS (MALAYSIA) SDN. BHD.
TEL: +60(3)7958-8355 FAX: +60(3)7958-8377

Philippines / ROHM ELECTRONICS (PHILIPPINES) SALES CORPORATION
TEL: +63(2)807-6872 FAX: +63(2)809-1422

Thailand / ROHM ELECTRONICS (THAILAND) CO., LTD.
TEL: +66(2)254-4890 FAX: +66(2)256-6334

AMEYA360

Components Supply Platform

Authorized Distribution Brand :



Website :

Welcome to visit www.ameya360.com

Contact Us :

➤ Address :

401 Building No.5, JiuGe Business Center, Lane 2301, Yishan Rd
Minhang District, Shanghai , China

➤ Sales :

Direct +86 (21) 6401-6692

Email amall@ameya360.com

QQ 800077892

Skype ameyasales1 ameyasales2

➤ Customer Service :

Email service@ameya360.com

➤ Partnership :

Tel +86 (21) 64016692-8333

Email mkt@ameya360.com