

Overvoltage protected AC switch

Datasheet – production data

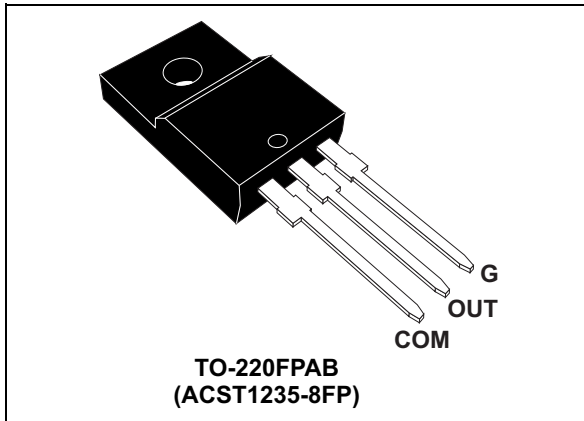

Description

The ACST1235-8FP belongs to the ACS™ / ACST power switch family built with A.S.D.® (application specific discrete) technology. This high performance device is suited to home appliances or industrial systems and drives loads up to 12 A.

This ACST1235-8FP switch embeds a Triac structure and a high voltage clamping device able to absorb the inductive turn-off energy and withstand line transients such as those described in the IEC 61000-4-5 standard. It offers an extremely high static dV/dt immunity of 2 kV/μs minimum at 150 °C junction temperature.

ACST1235-8FP enables applications to be compliant with IEC 61000-4-4 and IEC 61000-4-5.

Features

- 12 A medium current AC Switch
- Triac with self overvoltage protection
- High static immunity and dynamic commutation
- 800 V V_{DRM} / V_{RRM}
- High junction temperature: $T_j = 150\text{ °C}$ max
- Complies with UL standards (File ref: E81734)
- TO-220FPAB-insulated package 1500V_{RMS}
- ECOPACK®2 and RoHs compliant component

Applications

Motor control for home appliances:

- Washing machine universal drum motors
- Compressor of fridge or air conditioner

Figure 1. Functional diagram

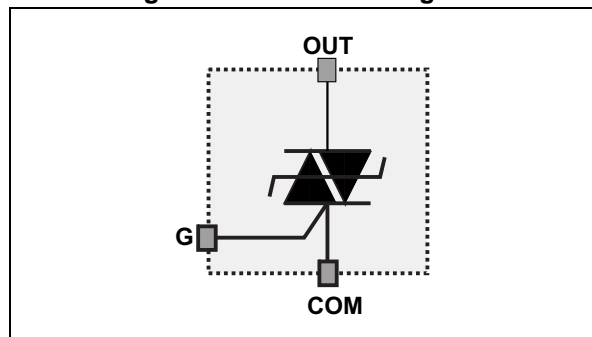

Table 1. Device summary

Symbol	Value	V_{DRM}/V_{RRM}
$I_{T(RMS)}$	12	A
I_{GT}	35	mA
V_{DRM}/V_{RRM}	800	V

1 Characteristics

Table 2. Absolute ratings (limiting values)

Symbol	Parameter	Test conditions	Value	Unit
$I_{T(RMS)}$	On-state rms current (full sine wave)	$T_c = 97\text{ °C}$	12	A
I_{TSM}	Non repetitive surge peak on-state current (T_j initial = 25 °C)	$t_p = 16.7\text{ ms}$	105	A
		$t_p = 20\text{ ms}$	100	
I^2t	I^2t value for fusing (full cycle sine wave)	$t_p = 10\text{ ms}$	66	A ² s
dI/dt	Critical rate of rise on-state current $I_G = 2 \times I_{GT}$, $t_r \leq 100\text{ ns}$	F = 60Hz $T_j = 150\text{ °C}$	100	A/μs
V_{DRM}/V_{RRM}	Repetitive peak off-state voltage	$T_j = 150\text{ °C}$	800	V
$V_{PP}^{(1)}$	Non repetitive line peak pulse voltage	$T_j = 25\text{ °C}$	2	kV
$(dI/dt)_{BO}^{(1)}$	Non repetitive critical current rate of rise at breakover	$T_j = 25\text{ °C}$	150	A/μs
I_{GM}	Peak gate current	$t_p = 20\text{ μs}$ $T_j = 150\text{ °C}$	1	A
P_{GM}	Peak gate power	$t_p = 20\text{ μs}$ $T_j = 150\text{ °C}$	10	W
$P_{G(AV)}$	Average gate power dissipation	$T_j = 150\text{ °C}$	0.1	W
T_{stg}	Storage junction temperature range		-40 to +150	°C
T_j	Operating junction temperature range		-40 to +150	°C
T_L	Maximum lead temperature for soldering during 10 s		260	°C
$V_{ins(rms)}$	Insulation rms voltage (60 seconds)		1.500	V

1. according to test described by standard IEC 61000-4-5 (see [Figure 19](#))

Table 3. Electrical characteristics

Symbol	Test conditions	Quadrant	T_j	Value		Unit
I_{GT}	$V_D = 12\text{ V}$, $R_L = 33\text{ Ω}$	I - II - III	25 °C	MAX.	35	mA
				MIN.	1.75	
V_{GT}	$V_D = 12\text{ V}$, $R_L = 33\text{ Ω}$	I - II - III	25 °C	MAX.	1.0	V
V_{GD}	$V_D = V_{DRM}$, $R_L = 3.3\text{ kΩ}$	I - II - III	150 °C	MIN.	0.2	V
$I_H^{(1)}$	$I_T = 500\text{ mA}$, gate open		25 °C	MAX.	30	mA
I_L	$I_G = 1.2 \times I_{GT}$	I - II - III	25 °C	MAX.	40	mA
dV/dt ⁽¹⁾	$V_D = 67\% V_{DRM}/V_{RRM}$, gate open		125 °C	MIN.	4000	V/μs
			150 °C	MIN.	2000	
$(dI/dt)_c^{(1)}$	Without snubber		125 °C	MIN.	12	A/ms
	$(dI/dt)_c = 15\text{ V/μs}$		150 °C	MIN.	6	
V_{CL}	$I_{CL} = 0.1\text{ mA}$, $t_p = 1\text{ ms}$			MIN.	850	V

1. For both polarities of OUT pin referenced to COM pin

Table 4. Static characteristics

Symbol	Test conditions		Value		Unit
$V_{TM}^{(1)}$	$I_{TM} = 17\text{ A}$, $t_p = 380\ \mu\text{s}$	$T_j = 25\ ^\circ\text{C}$	MAX.	1.5	V
$V_{to}^{(1)}$	Threshold voltage	$T_j = 150\ ^\circ\text{C}$	MAX.	0.9	V
$R_d^{(1)}$	Dynamic resistance	$T_j = 150\ ^\circ\text{C}$	MAX.	38	m Ω
I_{DRM} I_{RRM}	$V_{OUT} = V_{DRM} / V_{RRM}$	$T_j = 25\ ^\circ\text{C}$	MAX.	1	μA
		$T_j = 125\ ^\circ\text{C}$		500	μA
		$T_j = 150\ ^\circ\text{C}$		1.2	mA

1. For both polarities of OUT pin referenced to COM pin

Table 5. Thermal characteristics

Symbol	Parameter	Value	Unit
$R_{th(j-c)}$	Junction to case (AC)	3.5	$^\circ\text{C}/\text{W}$
$R_{th(j-a)}$	Junction to ambient (AC)	60	$^\circ\text{C}/\text{W}$

Figure 2. Maximum power dissipation versus rms on-state current (full cycle)

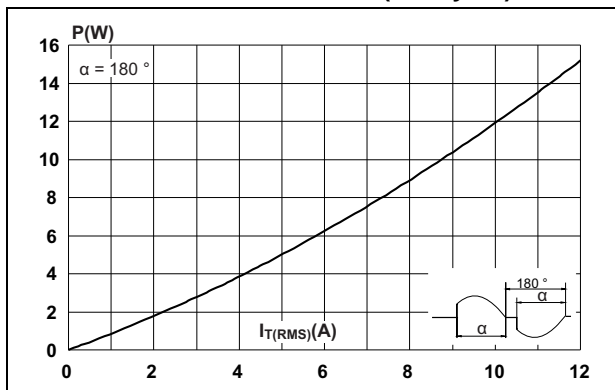

Figure 3. On-state rms current versus case temperature (full cycle)

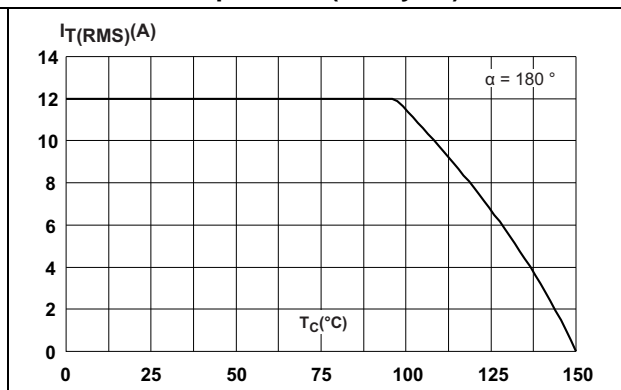

Figure 4. On-state rms current versus ambient temperature (free air convection)

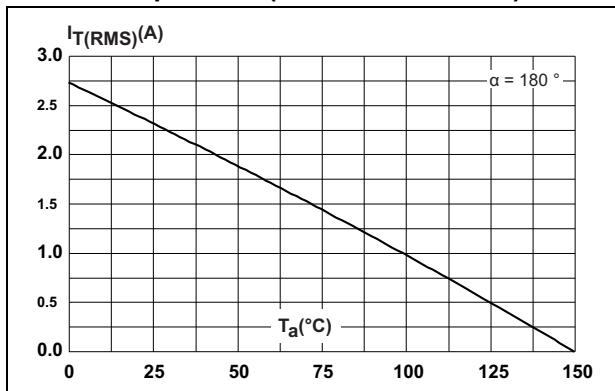

Figure 5. Relative variation of thermal impedance versus pulse duration

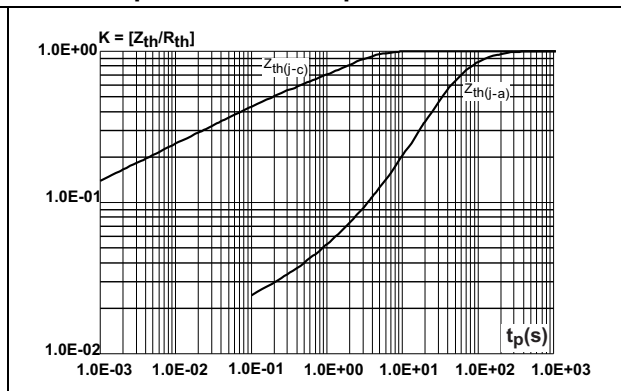

Figure 6. On-state characteristics (maximum values)

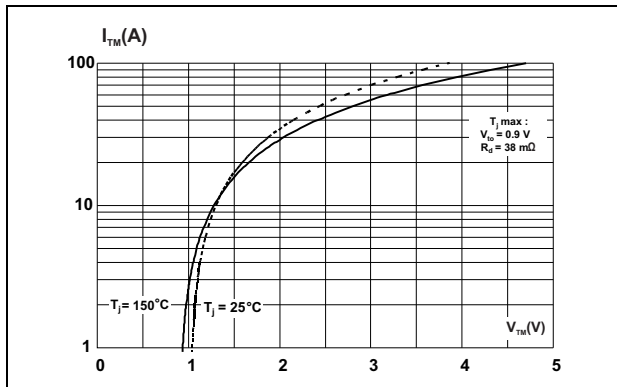

Figure 7. Surge peak on-state current versus number of cycles

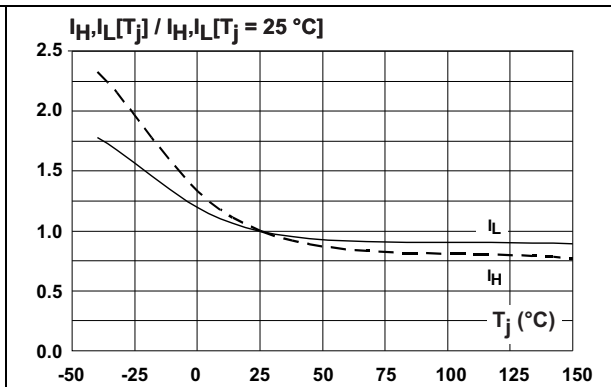

Figure 8. Non repetitive surge peak on-state current for a sinusoidal pulse with width $t_p < 10$ ms, and corresponding value of I^2t

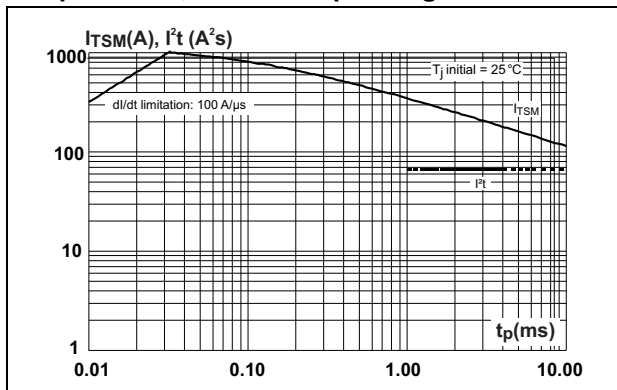

Figure 9. Relative variation of gate trigger current and gate trigger voltage versus junction temperature (typical values)

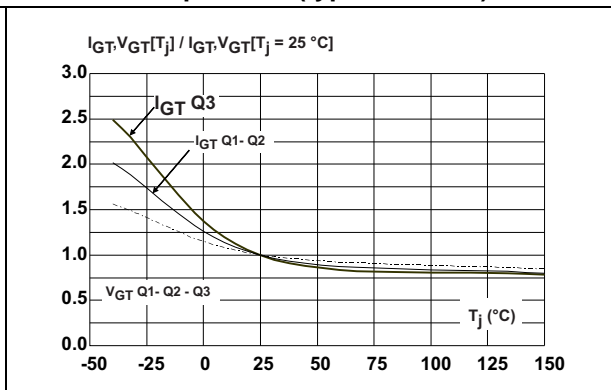

Figure 10. Relative variation of holding current and latching current versus junction temperature (typical values)

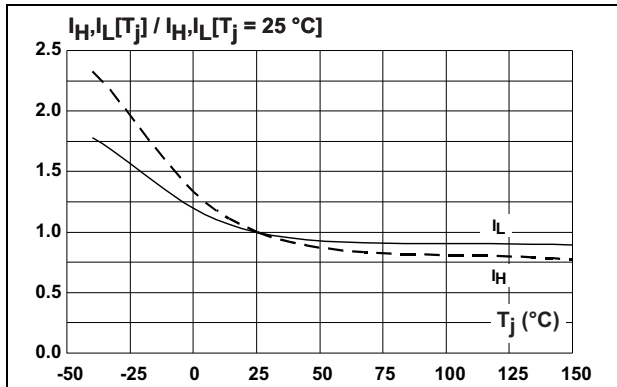

Figure 11. Relative variation of critical rate of decrease of main current (dI/dt)c versus reapplied (dV/dt)c

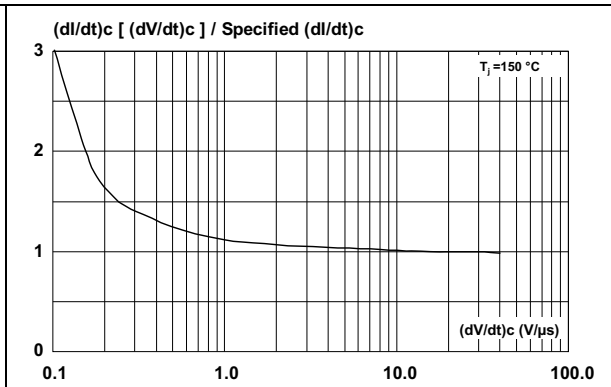

Figure 12. Relative variation of critical rate of decrease of main current versus junction temperature (typical values)

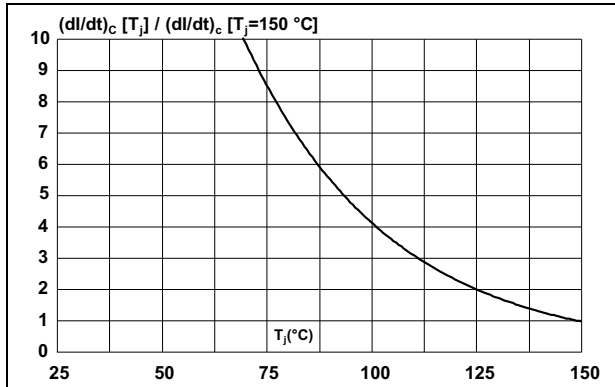

Figure 13. Relative variation of static dV/dt immunity versus junction temperature

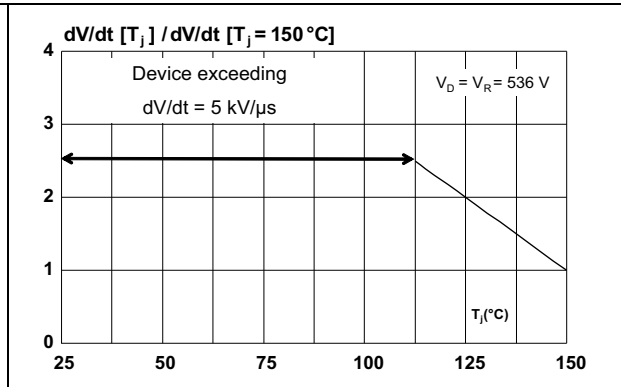

Figure 14. Relative variation of leakage current versus junction temperature for different values of blocking voltage (typical values)

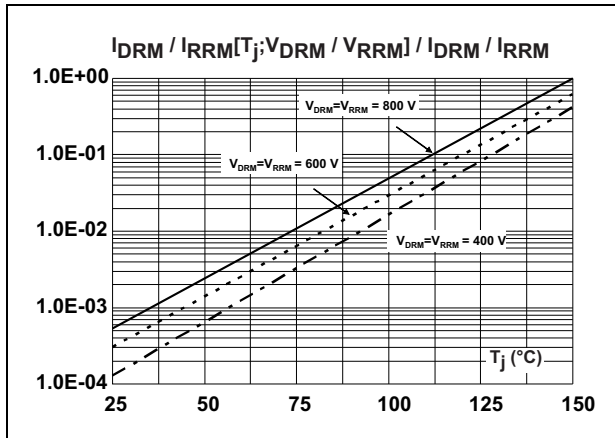
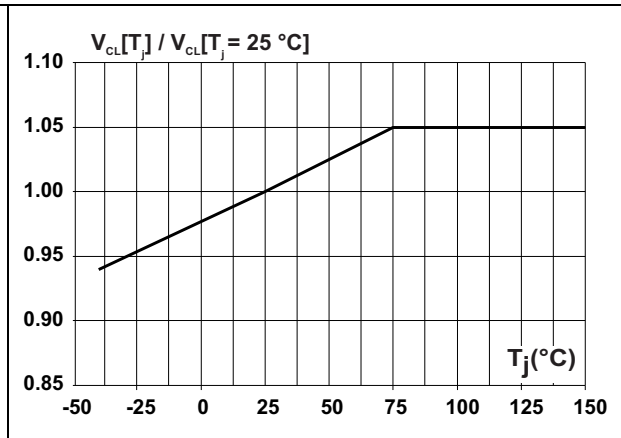

Figure 15. Relative variation of the maximum clamping voltage versus junction temperature (minimum values)



2 Application information

2.1 Typical application description

The ACST1235-8FP device has been designed to control medium power load, such as AC motors in home appliances. Thanks to its thermal and turn-off commutation performances, the ACST1235-8FP switch is able to drive an inductive load up to 12 A with no turn-off additional snubber. It also provides high thermal performances in static and transient modes such as the compressor inrush current or high torque operating conditions of an AC motor.

Figure 16. AC induction motor control - typical diagram

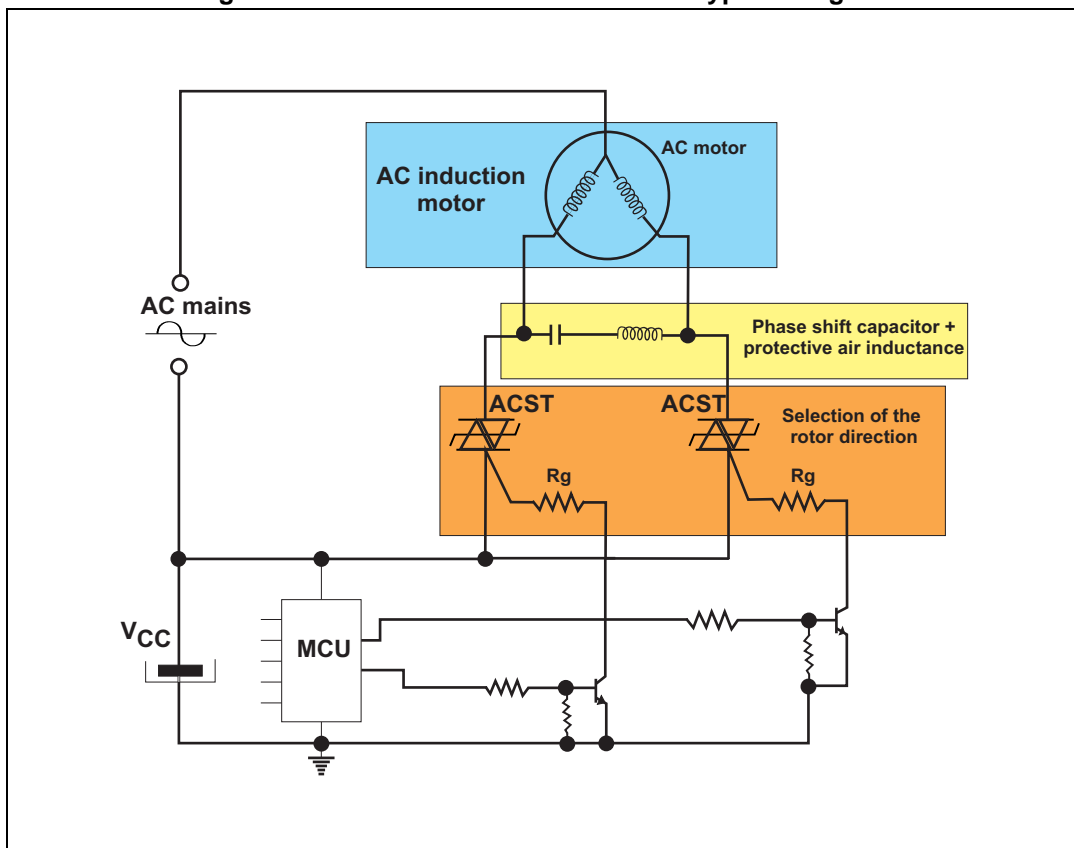
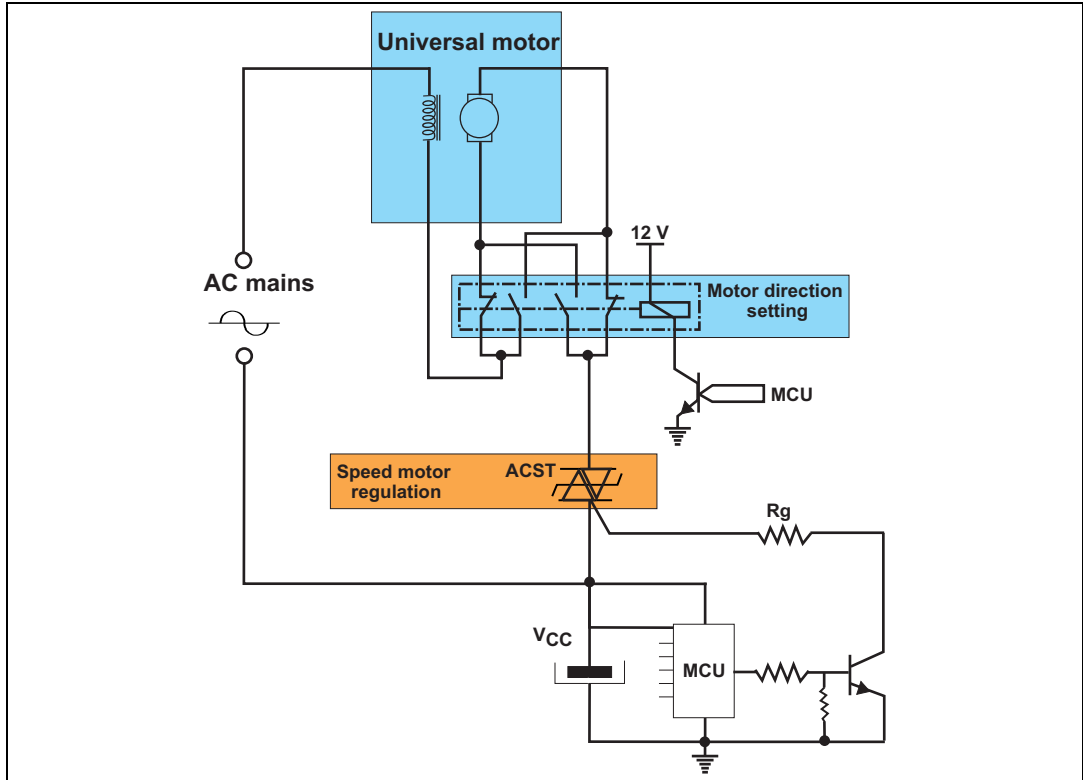
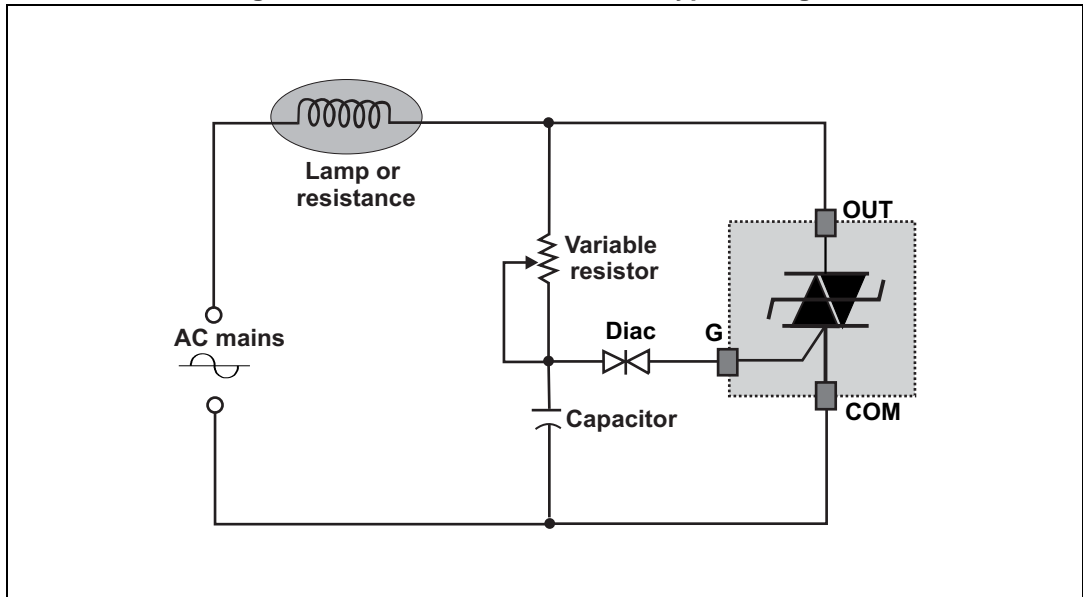

Figure 17. Universal drum motor control – typical diagram



The ACST1235-8FP device is also very effective in controlling resistive loads.

Figure 18. Resistive load control – typical diagram



2.2 AC line transient voltage ruggedness

In comparison with standard Triac, which need additional protection components against surge voltage, the ACST1235-8FP is self-protected against overvoltage, specified by the new parameter V_{CL} . The ACST1235-8FP switch can safely withstand AC line transient voltages either by clamping the low energy spikes, such as the inductive spikes at switch-off, or by switching to the on state (for less than 10 ms) to dissipate higher energy shocks through the load. This safety feature works even with high turn-on current ramp-up.

The test circuit of [Figure 19](#) represents the ACST1235-8FP application, and is used to stress the ACST switch according to the IEC 61000-4-5 standard conditions. With the additional effect of the load which limits the current, the ACST switch withstands the voltage spikes up to 2 kV on top of the peak line voltage. The protection is based on an overvoltage crowbar technology. The ACST1235-8FP folds back safely to the on state as shown in [Figure 20](#). The ACST1235-8FP recovers its blocking voltage capability after the surge and the next zero crossing current. Such a non repetitive test can be done at least 10 times on each AC line voltage polarity.

Figure 19. Overvoltage ruggedness test circuit for resistive and inductive loads for IEC 61000-4-5 standards

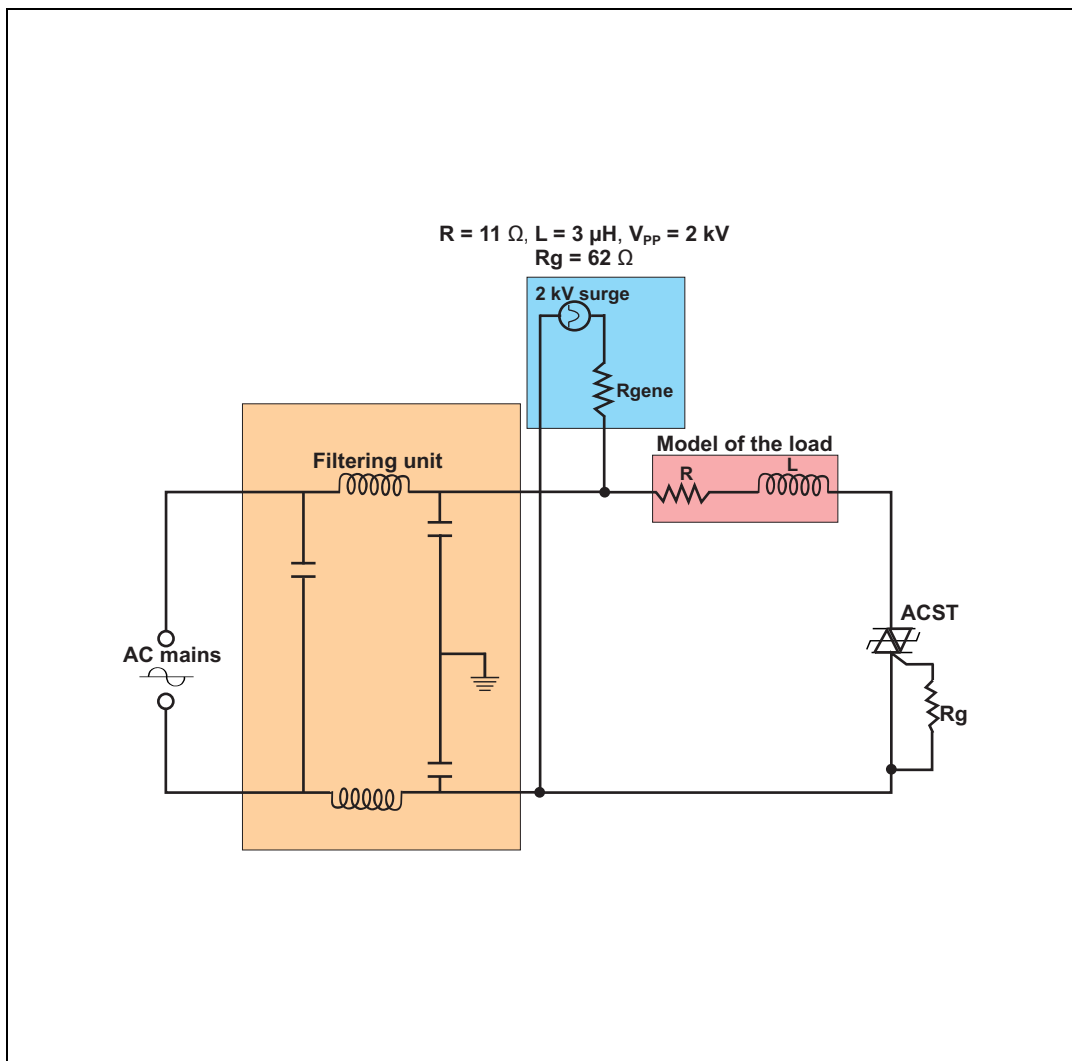
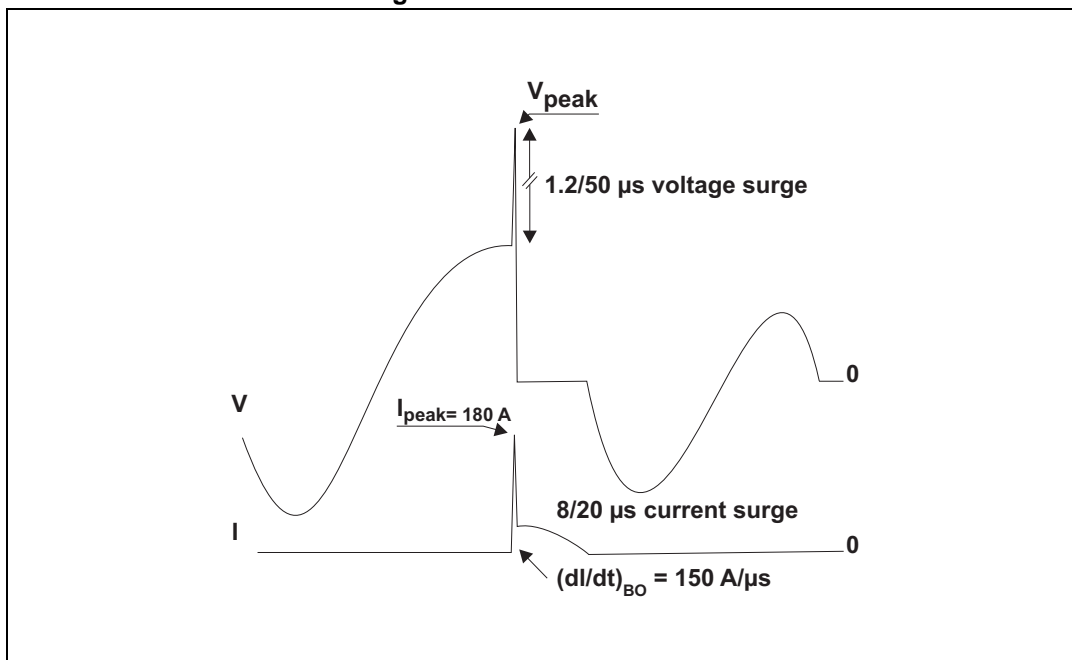

Figure 20. Typical voltage and current waveforms across the ACST1235-8FP during IEC 61000-4-5 standard test



3 Package information

- Lead-free package
- Recommended torque: 0.4 to 0.6 N·m

In order to meet environmental requirements, ST offers these devices in different grades of ECOPACK® packages, depending on their level of environmental compliance. ECOPACK® specifications, grade definitions and product status are available at: www.st.com. ECOPACK® is an ST trademark.

Figure 21. TO-220FPAB dimension definitions

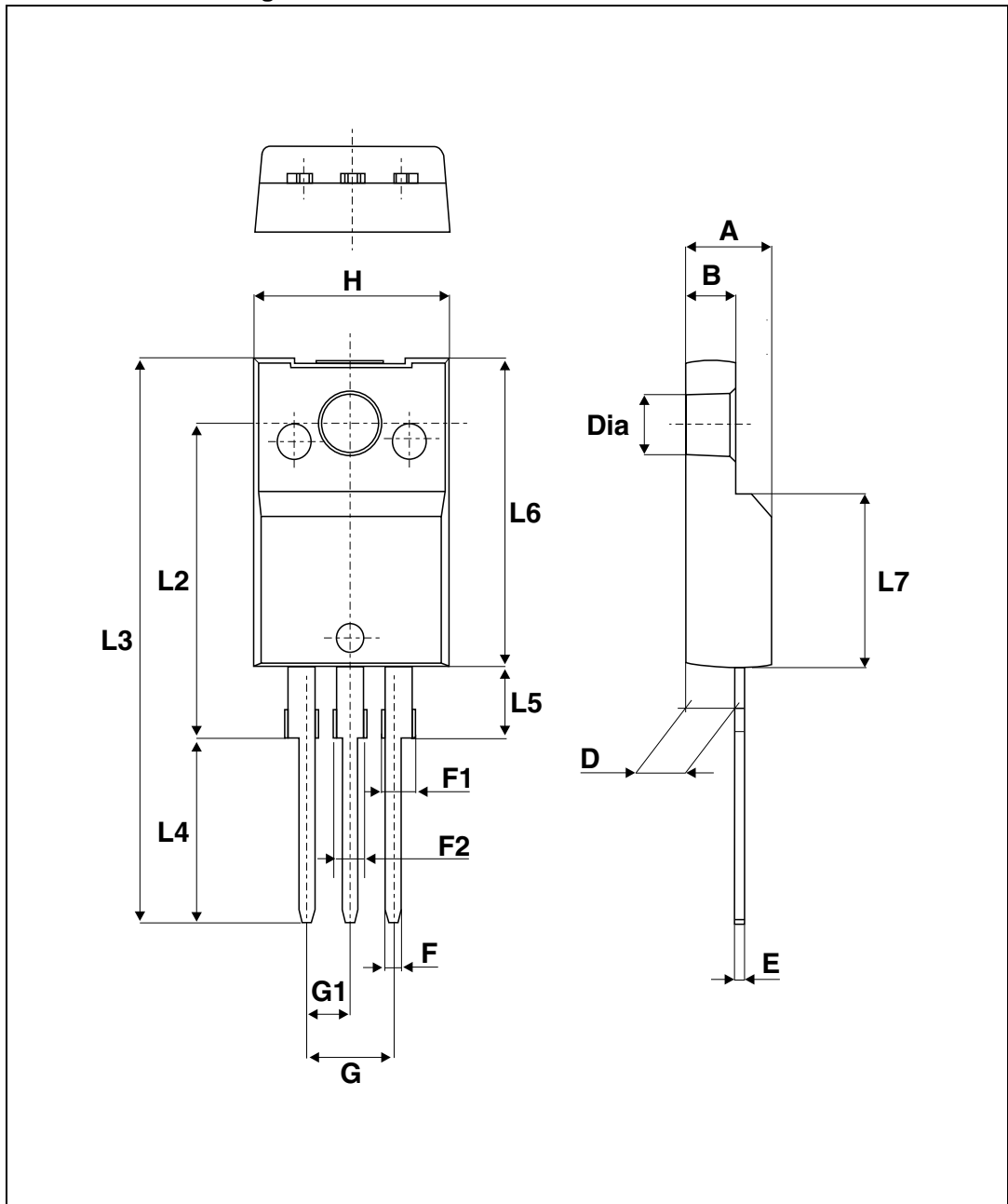

Table 6. TO-220FPAB dimension values

Ref.	Dimensions			
	Millimeters		Inches	
	Min.	Max.	Min.	Max.
A	4.4	4.6	0.173	0.181
B	2.5	2.7	0.098	0.106
D	2.5	2.75	0.098	0.108
E	0.45	0.70	0.018	0.027
F	0.75	1	0.030	0.039
F1	1.15	1.70	0.045	0.067
F2	1.15	1.70	0.045	0.067
G	4.95	5.20	0.195	0.205
G1	2.4	2.7	0.094	0.106
H	10	10.4	0.393	0.409
L2	16 Typ.		0.63 Typ.	
L3	28.6	30.6	1.126	1.205
L4	9.8	10.6	0.386	0.417
L5	2.9	3.6	0.114	0.142
L6	15.9	16.4	0.626	0.646
L7	9.00	9.30	0.354	0.366
Dia.	3.00	3.20	0.118	0.126

4 Ordering information

Figure 22. Ordering information scheme

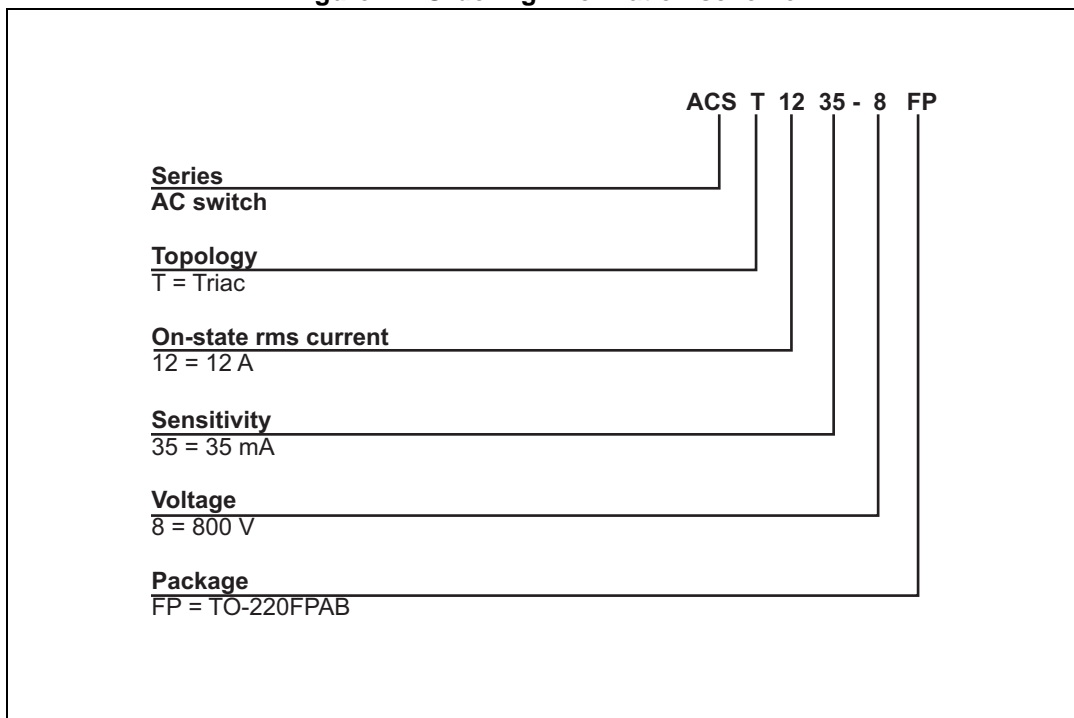

Table 7. Ordering information

Order code	Marking	Package	Weight	Base qty	Packing mode
ACST1235-8FP	ACST1235-8	TO-220FPAB	2.0 g	50	Tube

5 Revision history

Table 8. Document revision history

Date	Revision	Changes
24-Apr-2014	1	First issue.

Please Read Carefully:

Information in this document is provided solely in connection with ST products. STMicroelectronics NV and its subsidiaries ("ST") reserve the right to make changes, corrections, modifications or improvements, to this document, and the products and services described herein at any time, without notice.

All ST products are sold pursuant to ST's terms and conditions of sale.

Purchasers are solely responsible for the choice, selection and use of the ST products and services described herein, and ST assumes no liability whatsoever relating to the choice, selection or use of the ST products and services described herein.

No license, express or implied, by estoppel or otherwise, to any intellectual property rights is granted under this document. If any part of this document refers to any third party products or services it shall not be deemed a license grant by ST for the use of such third party products or services, or any intellectual property contained therein or considered as a warranty covering the use in any manner whatsoever of such third party products or services or any intellectual property contained therein.

UNLESS OTHERWISE SET FORTH IN ST'S TERMS AND CONDITIONS OF SALE ST DISCLAIMS ANY EXPRESS OR IMPLIED WARRANTY WITH RESPECT TO THE USE AND/OR SALE OF ST PRODUCTS INCLUDING WITHOUT LIMITATION IMPLIED WARRANTIES OF MERCHANTABILITY, FITNESS FOR A PARTICULAR PURPOSE (AND THEIR EQUIVALENTS UNDER THE LAWS OF ANY JURISDICTION), OR INFRINGEMENT OF ANY PATENT, COPYRIGHT OR OTHER INTELLECTUAL PROPERTY RIGHT.

ST PRODUCTS ARE NOT DESIGNED OR AUTHORIZED FOR USE IN: (A) SAFETY CRITICAL APPLICATIONS SUCH AS LIFE SUPPORTING, ACTIVE IMPLANTED DEVICES OR SYSTEMS WITH PRODUCT FUNCTIONAL SAFETY REQUIREMENTS; (B) AERONAUTIC APPLICATIONS; (C) AUTOMOTIVE APPLICATIONS OR ENVIRONMENTS, AND/OR (D) AEROSPACE APPLICATIONS OR ENVIRONMENTS. WHERE ST PRODUCTS ARE NOT DESIGNED FOR SUCH USE, THE PURCHASER SHALL USE PRODUCTS AT PURCHASER'S SOLE RISK, EVEN IF ST HAS BEEN INFORMED IN WRITING OF SUCH USAGE, UNLESS A PRODUCT IS EXPRESSLY DESIGNATED BY ST AS BEING INTENDED FOR "AUTOMOTIVE, AUTOMOTIVE SAFETY OR MEDICAL" INDUSTRY DOMAINS ACCORDING TO ST PRODUCT DESIGN SPECIFICATIONS. PRODUCTS FORMALLY ESCC, QML OR JAN QUALIFIED ARE DEEMED SUITABLE FOR USE IN AEROSPACE BY THE CORRESPONDING GOVERNMENTAL AGENCY.

Resale of ST products with provisions different from the statements and/or technical features set forth in this document shall immediately void any warranty granted by ST for the ST product or service described herein and shall not create or extend in any manner whatsoever, any liability of ST.

ST and the ST logo are trademarks or registered trademarks of ST in various countries.

Information in this document supersedes and replaces all information previously supplied.

The ST logo is a registered trademark of STMicroelectronics. All other names are the property of their respective owners.

© 2014 STMicroelectronics - All rights reserved

STMicroelectronics group of companies

Australia - Belgium - Brazil - Canada - China - Czech Republic - Finland - France - Germany - Hong Kong - India - Israel - Italy - Japan - Malaysia - Malta - Morocco - Philippines - Singapore - Spain - Sweden - Switzerland - United Kingdom - United States of America

www.st.com



AMEYA360

Components Supply Platform

Authorized Distribution Brand :



Website :

Welcome to visit www.ameya360.com

Contact Us :

➤ Address :

401 Building No.5, JiuGe Business Center, Lane 2301, Yishan Rd
Minhang District, Shanghai , China

➤ Sales :

Direct +86 (21) 6401-6692

Email amall@ameya360.com

QQ 800077892

Skype [ameyasales1](#) [ameyasales2](#)

➤ Customer Service :

Email service@ameya360.com

➤ Partnership :

Tel +86 (21) 64016692-8333

Email mkt@ameya360.com