

Piezo Film Vibra Tab (#605-00004)

The Piezo Film Vibra Tab sensor consists of a flexible piezoelectric film laminated to a polymer substrate. When the sensor is bent or displaced from its neutral axis, the strain within the piezo film generates voltage, up to 70 V voltages. A microcontroller can detect this voltage, making the Vibra Tab useful as an inexpensive switch or vibration sensor.

Features

- Two crimped contacts for mounting and electrical connections
- Sensitivity of 50 mV/g
- Generates voltage when vibrated, flicked, or bent, from 0 to 70 V
- Attach a small mass to decrease sensitivity and resonant frequency

Application Ideas

- Alarm system sensor
- Product damage/shock detector
- Acceleration sensor
- Tap switch

Example Circuit (With Clamping Diode)

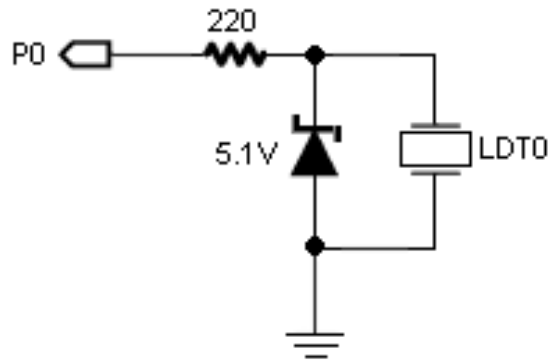

The circuit above allows you to start using the Vibra Tab as a switch or shock detector with a microcontroller. The 5.1 V Zener diode clamps the sensor's output voltage to protect microcontrollers whose I/O pins do not have internal clamping diodes. Use this circuit with the BASIC Stamp 2 example program, below. It tests the sensor for functionality by checking for a HIGH signal when the sensor is tapped, flicked or snapped. The BASIC Stamp microcontroller, SX microcontroller and Propeller chip have internal clamping diodes and do not require the 5.1 V Zener diode in the circuit.

CAUTION! This device can generate voltages of ~70 volts if bent to 90°. If your microcontroller does not have internal clamping/protection diodes on the I/O pins, be sure to clamp, buffer or filter the sensor's output signal to keep it within acceptable voltage/current limits for your microcontroller's I/O pin. See the manufacturer's datasheet for voltage output vs. tip deflection information.

Resources and Downloads

Check out the Piezo Film Vibra Tab product page for the manufacturer datasheet and example source code; go to www.parallax.com and enter "605-00004" in the search field.

Please see the manufacturer's website to obtain a Tech Manual, which describes more example applications, use of a mass to decrease sensitivity, configurations, and information on piezoelectric film devices.

<http://www.msiusa.com>

BASIC Stamp 2 Example Program

The example below provides a very simple method of reading the device as a vibration sensor or switch. This example will run on any BASIC Stamp 2 model, by updating the \$STAMP directive. It simply displays "Triggered!" on the Debug Terminal when the device is tapped, flicked or snapped. You could easily modify the code to branch to a subroutine on activation instead.

```
' File..... PiezoFilmTrigger.bs2
' Purpose... Detect Pulse On I/O
' Author.... Parallax Tech Support
' E-mail.... support@parallax.com
' {$STAMP BS2}
' {$PBASIC 2.5}
' =====

' -----[ Program Description ]-----
' This program demonstrates using the LDT0 as a switch/trigger

' -----[ I/O Definitions ]-----
TriggerPin      PIN      0              ' Input Pin From LDT0

' -----[ Program Code ]-----

DO
  IF TriggerPin = 1 THEN DEBUG "Triggered!", CR
  PAUSE 50
LOOP
```

Revision History

Version 1.1: revised product name to remove "mass." Updated product description and features, and explanation of the example circuit.

AMEYA360

Components Supply Platform

Authorized Distribution Brand :



Website :

Welcome to visit www.ameya360.com

Contact Us :

➤ Address :

401 Building No.5, JiuGe Business Center, Lane 2301, Yishan Rd
Minhang District, Shanghai , China

➤ Sales :

Direct +86 (21) 6401-6692

Email amall@ameya360.com

QQ 800077892

Skype [ameyasales1](#) [ameyasales2](#)

➤ Customer Service :

Email service@ameya360.com

➤ Partnership :

Tel +86 (21) 64016692-8333

Email mkt@ameya360.com