

## N-channel 600 V, 0.175 $\Omega$ typ., 19.5 A, FDmesh™ II Power MOSFET (with fast diode) in PowerFLAT™ 8x8 HV package

Datasheet – production data

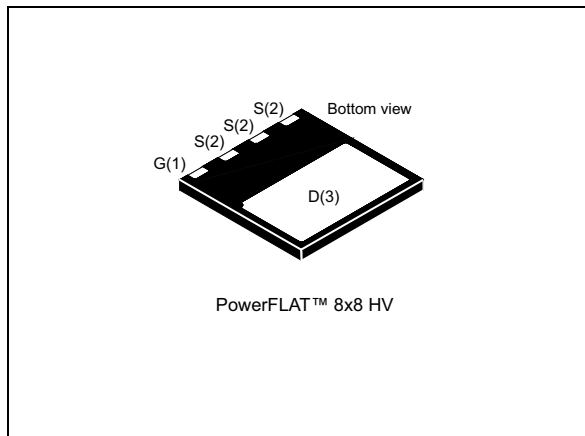
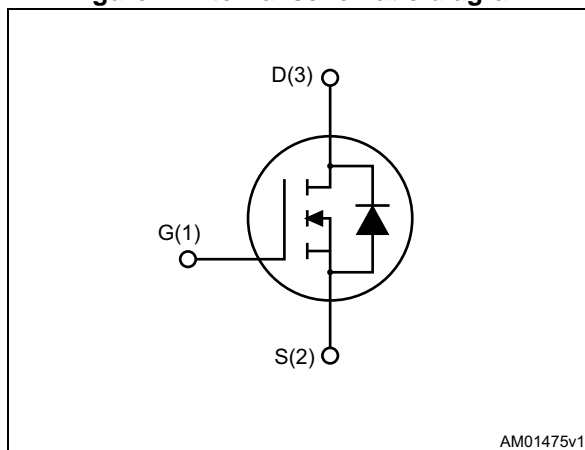

Figure 1. Internal schematic diagram



### Features

Order code	$V_{DS} @ T_{Jmax}$	$R_{DS(on) max}$	$I_D$
STL23NM60ND	650 V	0.199 $\Omega$	19.5 A

- Fast-recovery body diode
- Low gate charge and input capacitance
- Low on-resistance
- 100% avalanche tested
- High dv/dt ruggedness

### Applications

- Switching applications

### Description

This FDmesh™ II Power MOSFET with fast-recovery body diode is produced using MDmesh™ II technology. Utilizing a new strip-lay-out vertical structure, this device features low on-resistance and superior switching performance. It is ideal for bridge topologies and ZVS phase-shift converters.

Table 1. Device summary

Order code	Marking	Package	Packaging
STL23NM60ND	23NM60ND	PowerFLAT™ 8x8 HV	Tape and reel

## Contents

<b>1</b>	<b>Electrical ratings</b> .....	<b>3</b>
<b>2</b>	<b>Electrical characteristics</b> .....	<b>4</b>
2.1	Electrical characteristics (curves) .....	6
<b>3</b>	<b>Test circuits</b> .....	<b>8</b>
<b>4</b>	<b>Package mechanical data</b> .....	<b>9</b>
<b>5</b>	<b>Packaging mechanical data</b> .....	<b>13</b>
<b>6</b>	<b>Revision history</b> .....	<b>15</b>

# 1 Electrical ratings

**Table 2. Absolute maximum ratings**

Symbol	Parameter	Value	Unit
$V_{DS}$	Drain-source voltage	600	V
$V_{GS}$	Gate-source voltage	$\pm 25$	V
$I_D^{(1)}$	Drain current (continuous) at $T_C = 25\text{ }^\circ\text{C}$	19.5	A
$I_D^{(1)}$	Drain current (continuous) at $T_C = 100\text{ }^\circ\text{C}$	11.7	A
$I_{DM}^{(1),(2)}$	Drain current (pulsed)	78	A
$I_D^{(3)}$	Drain current (continuous) at $T_{amb} = 25\text{ }^\circ\text{C}$	2.75	A
$I_D^{(3)}$	Drain current (continuous) at $T_{amb} = 100\text{ }^\circ\text{C}$	1.75	A
$I_{DM}^{(2),(3)}$	Drain current (pulsed)	11	A
$P_{TOT}^{(1)}$	Total dissipation at $T_C = 25\text{ }^\circ\text{C}$	150	W
$P_{TOT}^{(3)}$	Total dissipation at $T_{amb} = 25\text{ }^\circ\text{C}$	3	W
$I_{AR}$	Avalanche current, repetitive or not-repetitive (pulse width limited by $T_j$ max)	9	A
$E_{AS}$	Single pulse avalanche energy (starting $T_j = 25\text{ }^\circ\text{C}$ , $I_D = I_{AR}$ , $V_{DD} = 50\text{ V}$ )	700	mJ
$dv/dt^{(4)}$	Peak diode recovery voltage slope	40	V/ns
$T_{stg}$	Storage temperature	- 55 to 150	$^\circ\text{C}$
$T_j$	Max. operating junction temperature	150	$^\circ\text{C}$

1. The value is rated according to  $R_{thj-case}$
2. Pulse width limited by safe operating area.
3. When mounted on FR-4 board of inch<sup>2</sup>, 2oz Cu.
4.  $I_{SD} \leq 19.5\text{ A}$ ,  $di/dt \leq 600\text{ A}/\mu\text{s}$ ,  $V_{DD} = 80\% V_{(BR)DSS}$ ,  $V_{DS(peak)} < V_{(BR)DSS}$

**Table 3. Thermal data**

Symbol	Parameter	Value	Unit
$R_{thj-case}$	Thermal resistance junction-case max	0.83	$^\circ\text{C}/\text{W}$
$R_{thj-amb}^{(1)}$	Thermal resistance junction-ambient max	45	$^\circ\text{C}/\text{W}$

1. When mounted on FR-4 board of inch<sup>2</sup>, 2oz Cu.

## 2 Electrical characteristics

( $T_C = 25\text{ °C}$  unless otherwise specified)

**Table 4. On /off states**

Symbol	Parameter	Test conditions	Min.	Typ.	Max.	Unit
$V_{(BR)DSS}$	Drain-source breakdown voltage	$V_{GS} = 0, I_D = 1\text{ mA}$	600			V
$dv/dt^{(1)}$	Drain-source voltage slope	$V_{DD} = 480\text{ V}, I_D = 19.5\text{ A}, V_{GS} = 10\text{ V}$		30		V/ns
$I_{DSS}$	Zero gate voltage drain current	$V_{GS} = 0, V_{DS} = 600\text{ V}$			1	$\mu\text{A}$
		$V_{GS} = 0, V_{DS} = 600\text{ V}, T_C = 125\text{ °C}$			100	$\mu\text{A}$
$I_{GSS}$	Gate-body leakage current	$V_{DS} = 0, V_{GS} = \pm 20\text{ V}$			$\pm 100$	nA
$V_{GS(th)}$	Gate threshold voltage	$V_{DS} = V_{GS}, I_D = 250\text{ }\mu\text{A}$	3	4	5	V
$R_{DS(on)}$	Static drain-source on-resistance	$V_{GS} = 10\text{ V}, I_D = 10\text{ A}$		0.175	0.199	$\Omega$

1. Characteristic value at turn off on inductive load

**Table 5. Dynamic**

Symbol	Parameter	Test conditions	Min.	Typ.	Max.	Unit
$C_{iss}$	Input capacitance	$V_{DS} = 50\text{ V}, f = 1\text{ MHz}, V_{GS} = 0$	-	2100	-	pF
$C_{oss}$	Output capacitance		-	80	-	pF
$C_{riss}$	Reverse transfer capacitance		-	10	-	pF
$C_{oss\text{ eq}}^{(1)}$	Equivalent output capacitance	$V_{GS} = 0, V_{DS} = 0\text{ to }480\text{ V}$	-	310	-	pF
$R_G$	Intrinsic gate resistance	$f = 1\text{ MHz}, \text{ gate DC Bias} = 0, \text{ test signal level} = 20\text{ mV}$	-	4	-	$\Omega$
$Q_g$	Total gate charge	$V_{DD} = 480\text{ V}, I_D = 19.5\text{ A}, V_{GS} = 10\text{ V}, \text{ (see Figure 14)}$	-	69	-	nC
$Q_{gs}$	Gate-source charge		-	13	-	nC
$Q_{gd}$	Gate-drain charge		-	35	-	nC

1.  $C_{oss\text{ eq}}$  is defined as a constant equivalent capacitance giving the same charging time as  $C_{oss}$  when  $V_{DS}$  increases from 0 to 80%  $V_{DSS}$

Table 6. Switching times

Symbol	Parameter	Test conditions	Min.	Typ.	Max.	Unit
$t_{d(on)}$	Turn-on delay time	$V_{DD} = 300\text{ V}$ , $I_D = 10\text{ A}$ , $R_G = 4.7\ \Omega$ , $V_{GS} = 10\text{ V}$ (see <a href="#">Figure 13</a> )	-	21	-	ns
$t_r$	Voltage rise time		-	19	-	ns
$t_{d(off)}$	Turn-off delay time		-	92	-	ns
$t_f$	Current fall time		-	42	-	ns

Table 7. Source drain diode

Symbol	Parameter	Test conditions	Min.	Typ.	Max.	Unit
$I_{SD}$	Source-drain current		-		19.5	A
$I_{SDM}^{(1)}$	Source-drain current (pulsed)		-		78	A
$V_{SD}^{(2)}$	Forward on voltage	$I_{SD} = 19.5\text{ A}$ , $V_{GS} = 0$	-		1.3	V
$t_{rr}$	Reverse recovery time	$I_{SD} = 19.5\text{ A}$ , $di/dt = 100\text{ A}/\mu\text{s}$ , $V_{DD} = 60\text{ V}$ (see <a href="#">Figure 15</a> )	-	190		ns
$Q_{rr}$	Reverse recovery charge		-	1.2		$\mu\text{C}$
$I_{RRM}$	Reverse recovery current		-	13		A
$t_{rr}$	Reverse recovery time	$I_{SD} = 19.5\text{ A}$ , $di/dt = 100\text{ A}/\mu\text{s}$ , $V_{DD} = 100\text{ V}$ , $T_j = 150\text{ }^\circ\text{C}$ (see <a href="#">Figure 15</a> )	-	270		ns
$Q_{rr}$	Reverse recovery charge		-	2.0		$\mu\text{C}$
$I_{RRM}$	Reverse recovery current		-	15		A

1. Pulse width limited by safe operating area
2. Pulsed: pulse duration = 300  $\mu\text{s}$ , duty cycle 1.5%

## 2.1 Electrical characteristics (curves)

Figure 2. Safe operating area

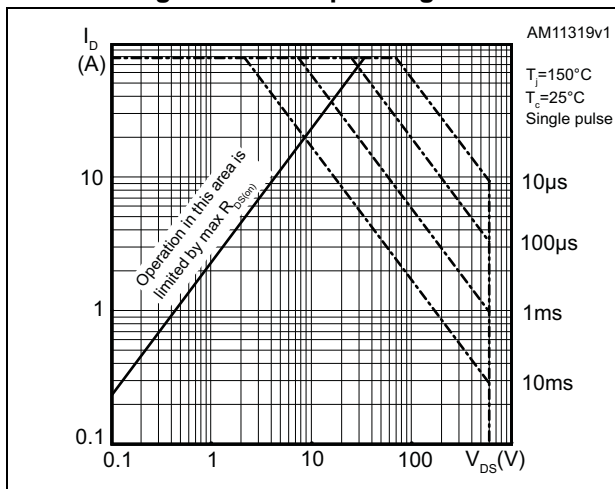

Figure 3. Thermal impedance

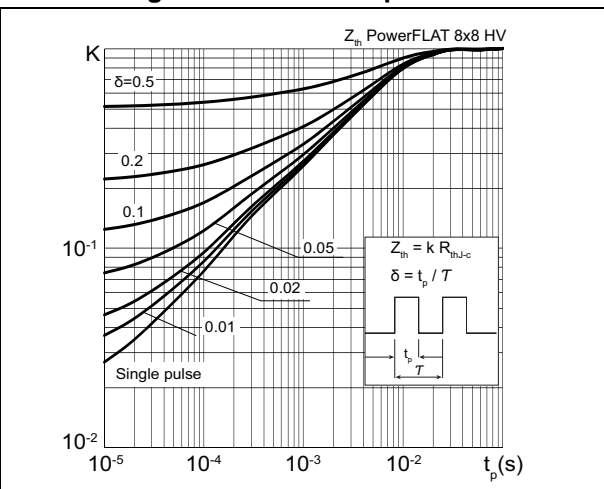

Figure 4. Output characteristics

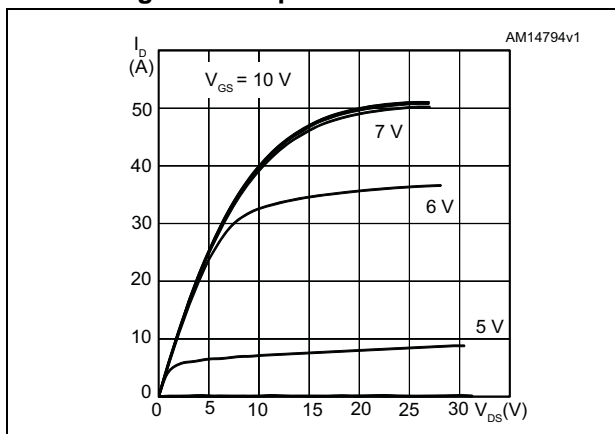

Figure 5. Transfer characteristics

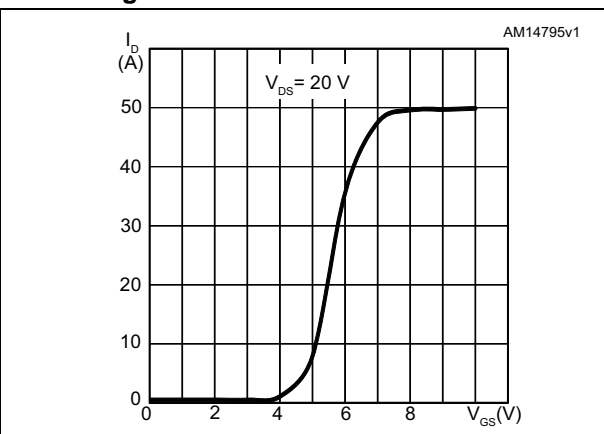

Figure 6. Normalized  $B_{(BR)DSS}$  vs temperature

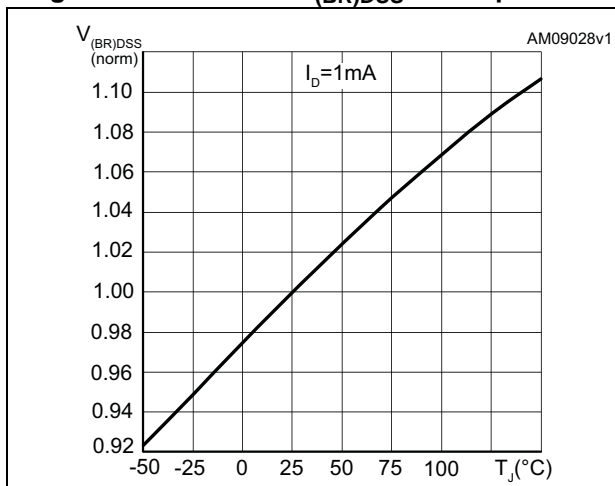

Figure 7. Static drain-source on-resistance

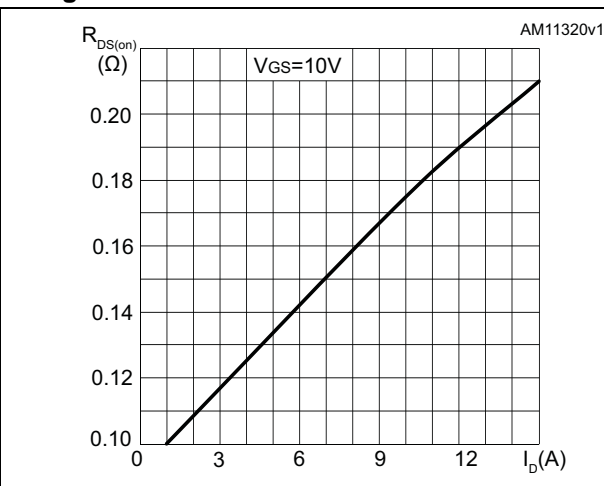

Figure 8. Gate charge vs gate-source voltage

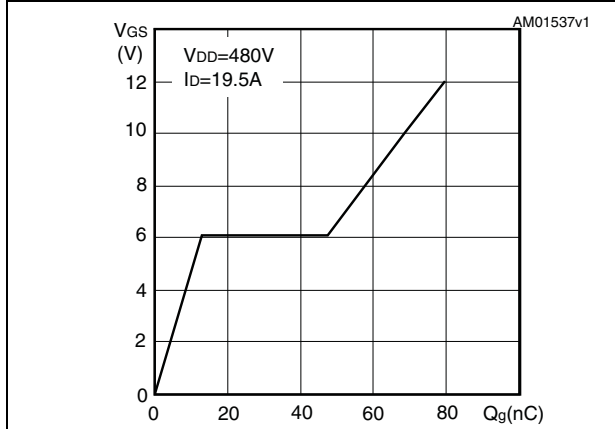

Figure 9. Capacitance variations

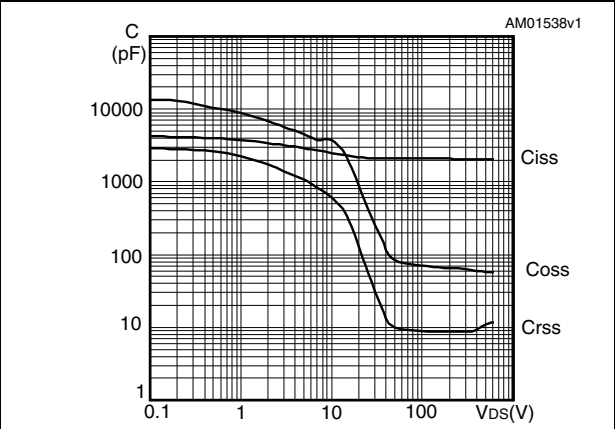

Figure 10. Normalized gate threshold voltage vs temperature

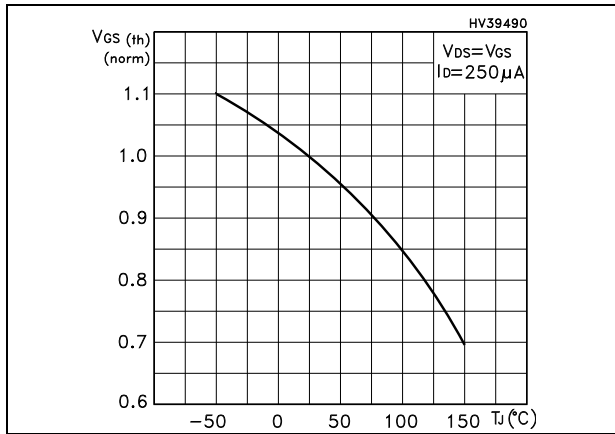

Figure 11. Normalized on-resistance vs temperature

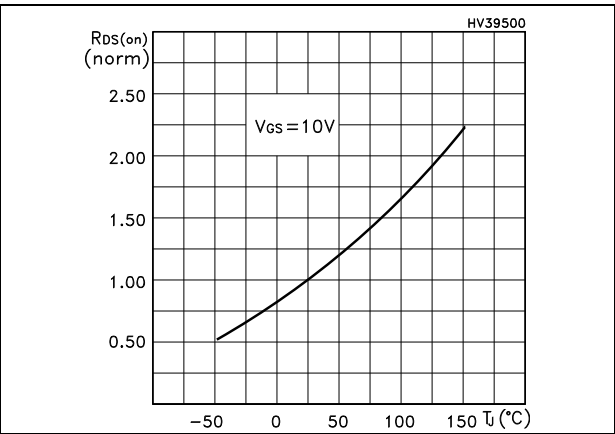
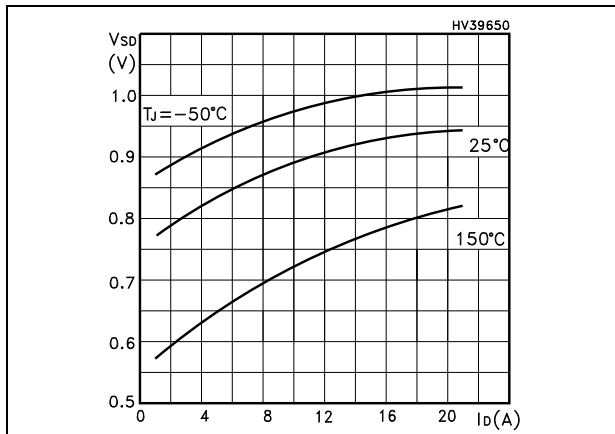

Figure 12. Source-drain diode forward characteristics



### 3 Test circuits

Figure 13. Switching times test circuit for resistive load

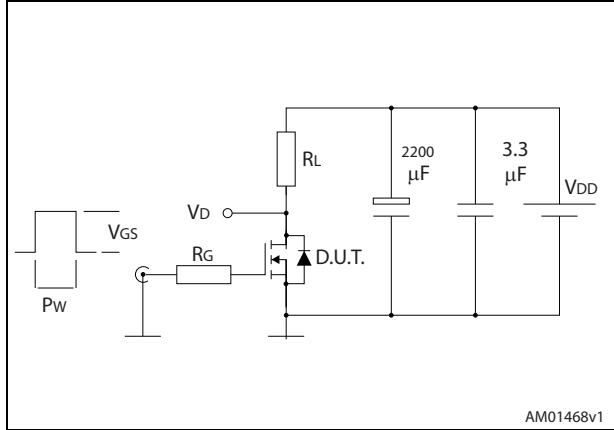

Figure 14. Gate charge test circuit

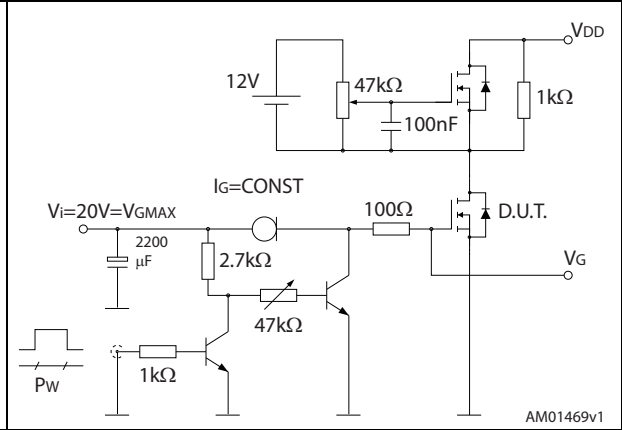

Figure 15. Test circuit for inductive load switching and diode recovery times

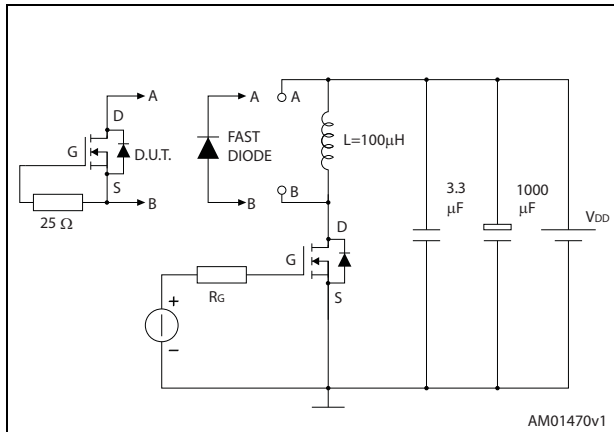

Figure 16. Unclamped inductive load test circuit

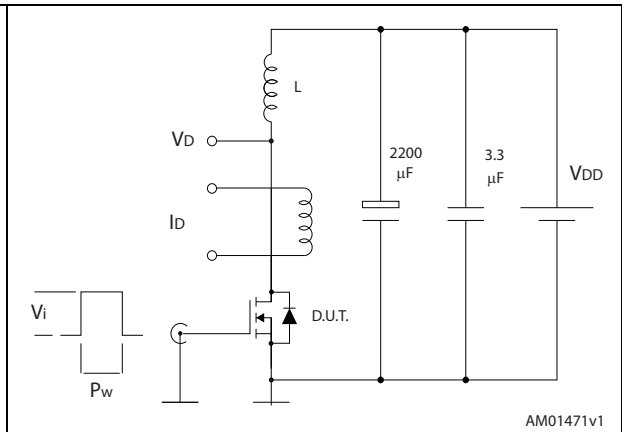

Figure 17. Unclamped inductive waveform

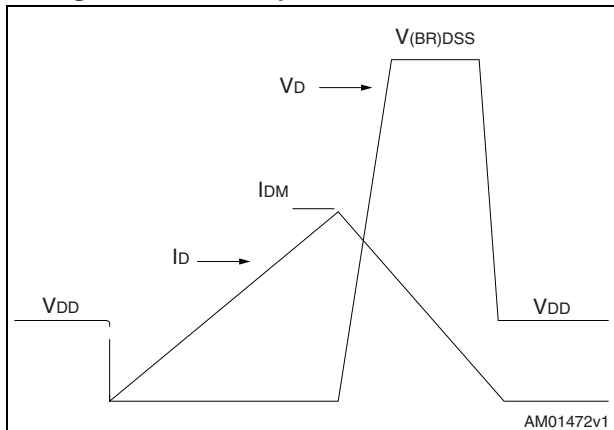
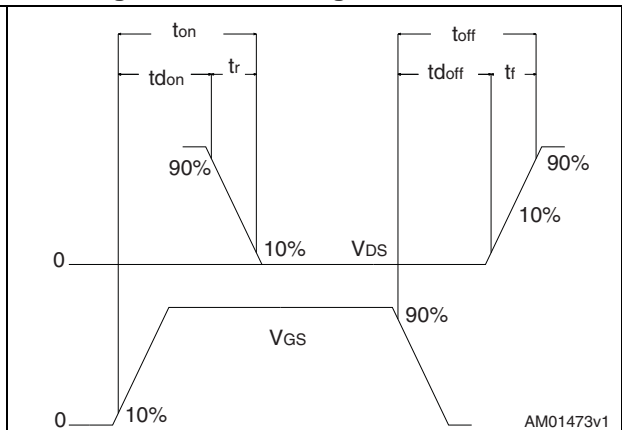

Figure 18. Switching time waveform



## 4 Package mechanical data

In order to meet environmental requirements, ST offers these devices in different grades of ECOPACK<sup>®</sup> packages, depending on their level of environmental compliance. ECOPACK<sup>®</sup> specifications, grade definitions and product status are available at: [www.st.com](http://www.st.com). ECOPACK<sup>®</sup> is an ST trademark.

Figure 19. PowerFLAT™ 8x8 HV drawing mechanical data

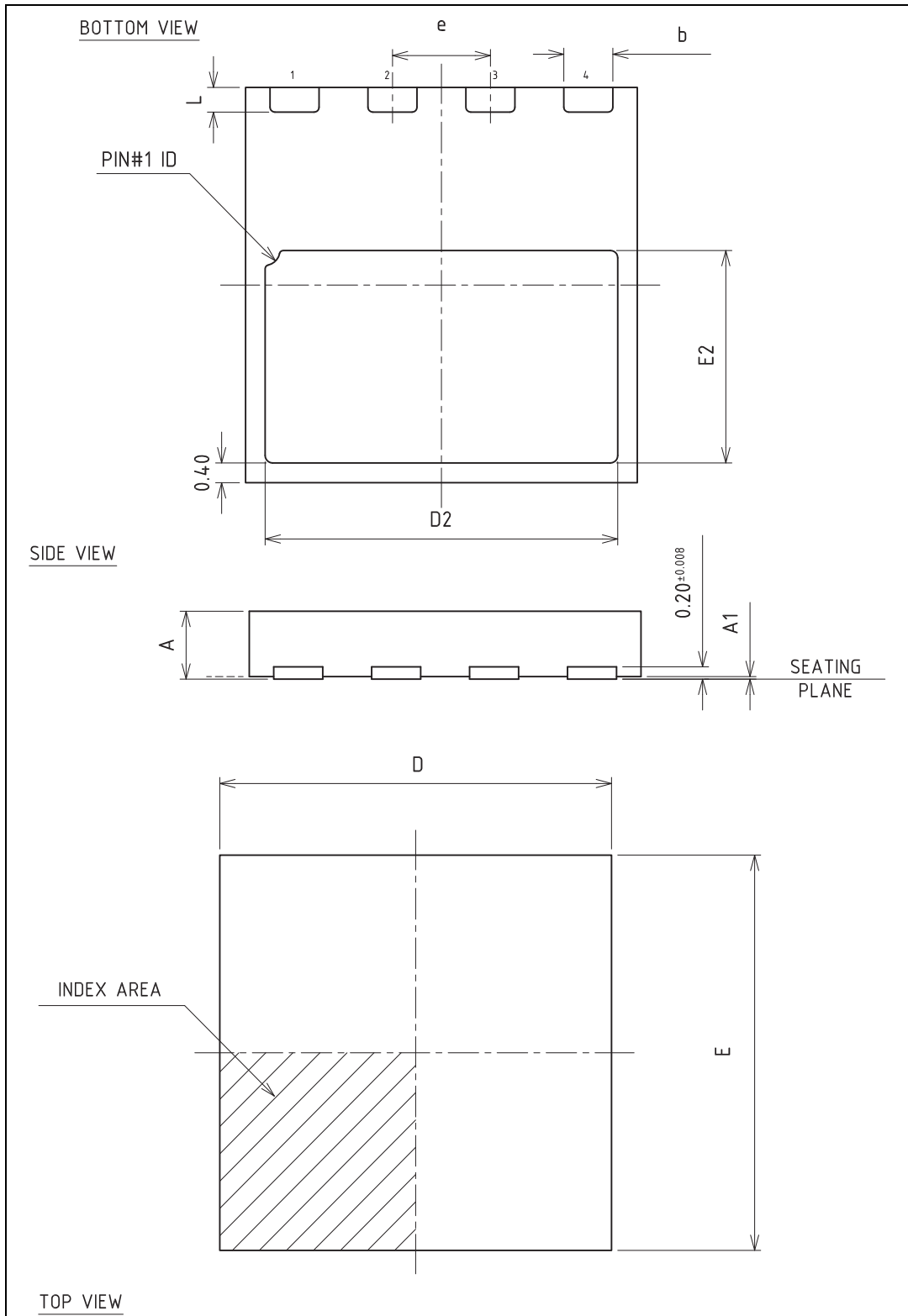
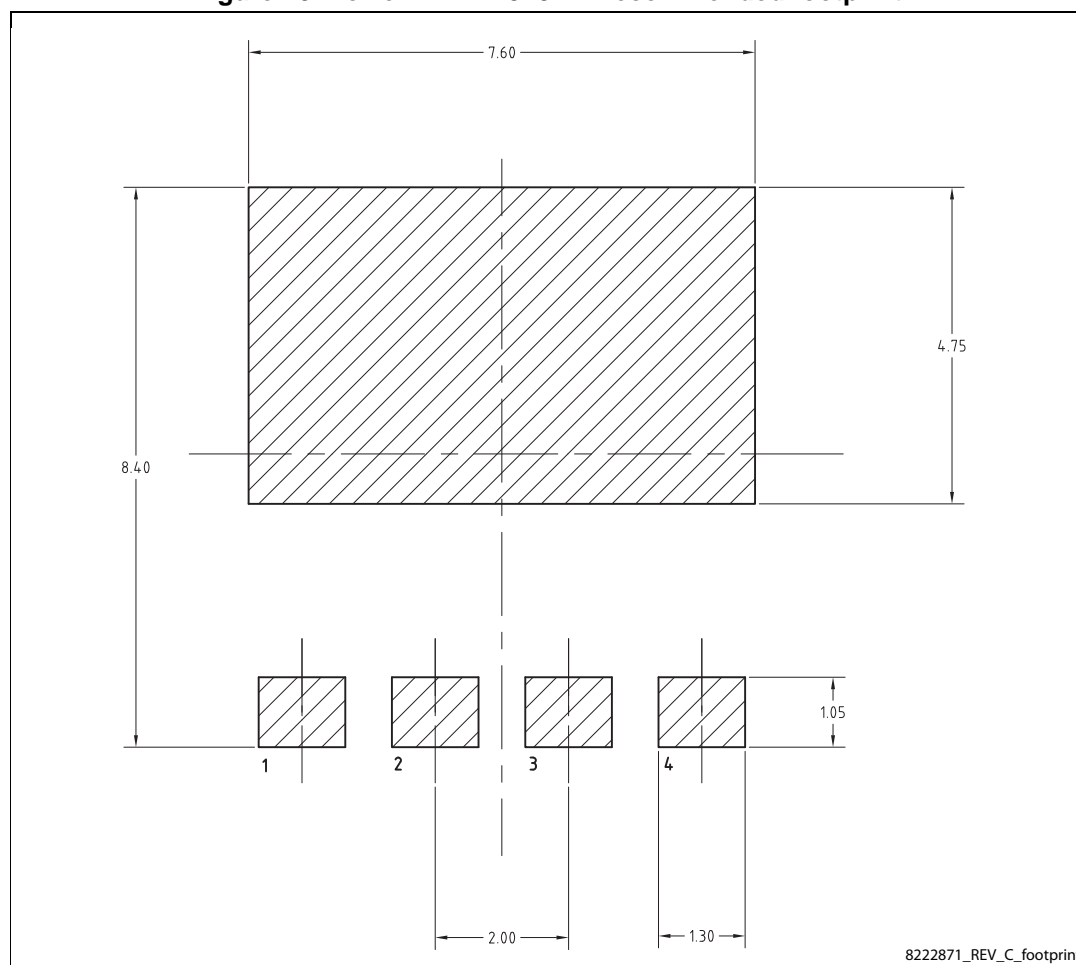

Table 8. PowerFLAT™ 8x8 HV mechanical data

Dim.	mm		
	Min.	Typ.	Max.
A	0.80	0.90	1.00
A1	0.00	0.02	0.05
b	0.95	1.00	1.05
D		8.00	
E		8.00	
D2	7.05	7.20	7.30
E2	4.15	4.30	4.40
e		2.00	
L	0.40	0.50	0.60

Figure 20. PowerFLAT™ 8x8 HV recommended footprint



# 5 Packaging mechanical data

Figure 21. PowerFLAT™ 8x8 HV tape

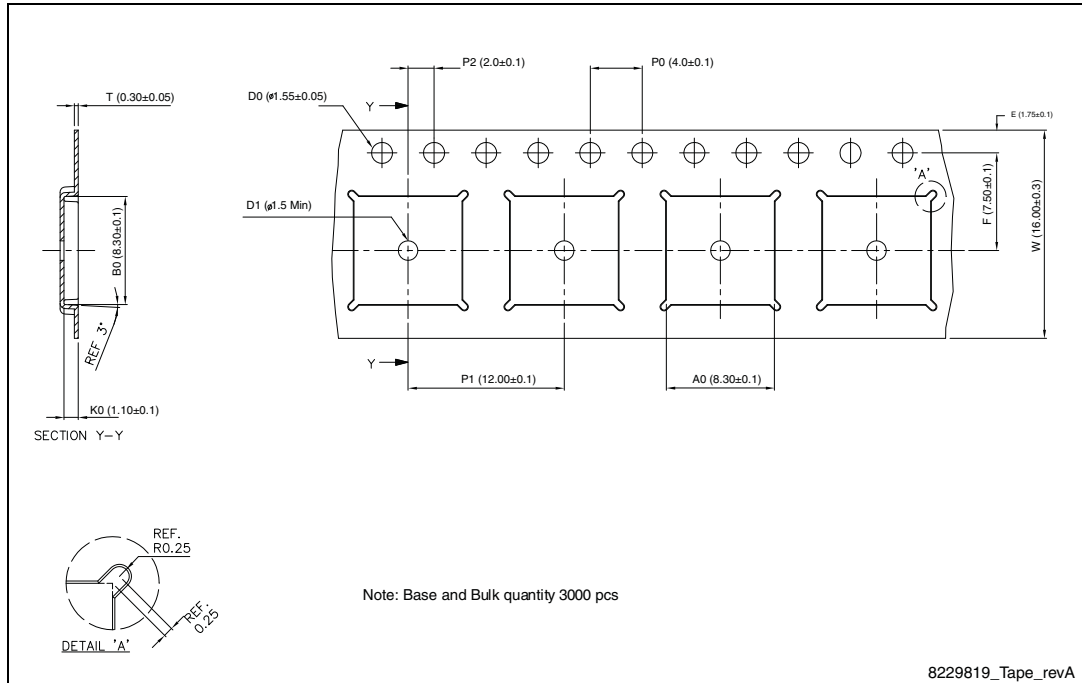

Figure 22. PowerFLAT™ 8x8 HV package orientation in carrier tape.

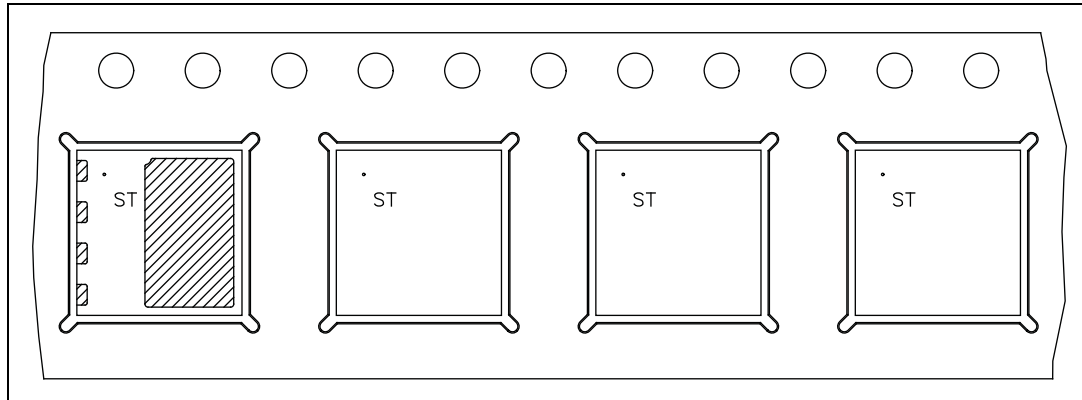
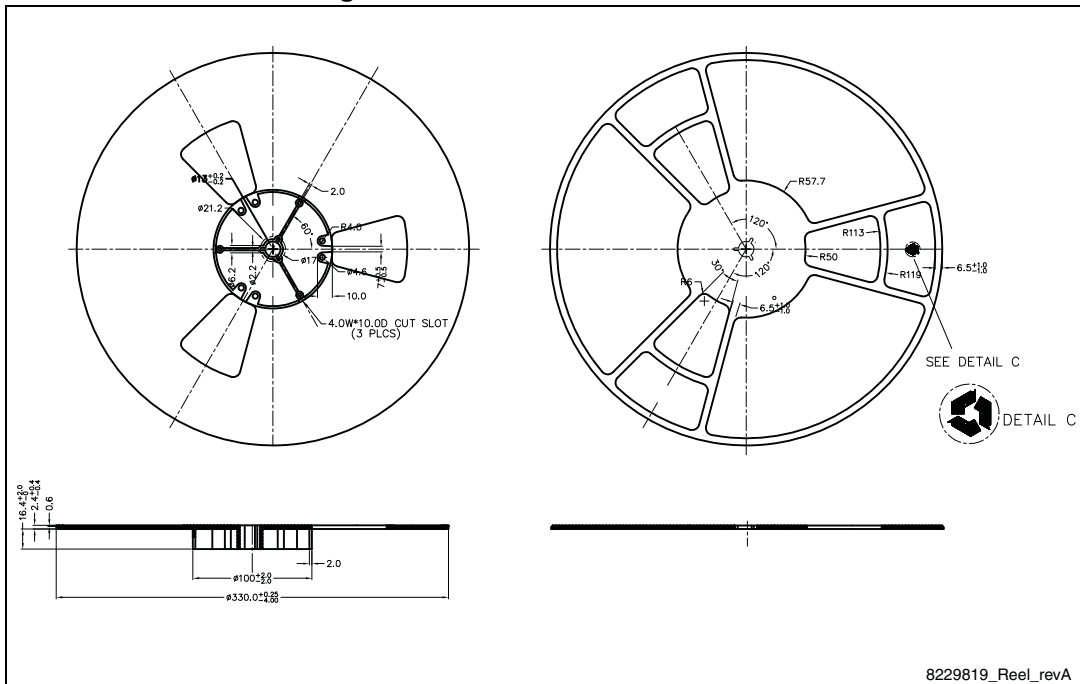

Figure 23. PowerFLAT™ 8x8 HV reel



## 6 Revision history

**Table 9. Document revision history**

Date	Revision	Changes
28-Apr-2010	1	First release.
01-Mar-2013	2	<ul style="list-style-type: none"><li>– <a href="#">Section 4: Package mechanical data</a> has been modified.</li><li>– <a href="#">Section 2.1: Electrical characteristics (curves)</a> has been inserted.</li><li>– Minor text changes.</li></ul>
17-Dec-2014	3	<p>Minor text and formatting changes throughout document.</p> <p>On Cover page, updated Features and Description.</p> <p>In <a href="#">Table 2: Absolute maximum ratings</a>, changed Values for both P<sub>TOT</sub> rows.</p> <p>In <a href="#">Table 7: Source drain diode</a>, changed Units for both Q<sub>rr</sub> rows.</p> <p>In <a href="#">Figure 3: Thermal impedance</a>, added inset with plot and formulas.</p> <p>In <a href="#">Section 3: Test circuits</a>, updated figures.</p> <p>In <a href="#">Section 4: Package mechanical data</a>, updated figures and tables.</p>

**IMPORTANT NOTICE – PLEASE READ CAREFULLY**

STMicroelectronics NV and its subsidiaries ("ST") reserve the right to make changes, corrections, enhancements, modifications, and improvements to ST products and/or to this document at any time without notice. Purchasers should obtain the latest relevant information on ST products before placing orders. ST products are sold pursuant to ST's terms and conditions of sale in place at the time of order acknowledgement.

Purchasers are solely responsible for the choice, selection, and use of ST products and ST assumes no liability for application assistance or the design of Purchasers' products.

No license, express or implied, to any intellectual property right is granted by ST herein.

Resale of ST products with provisions different from the information set forth herein shall void any warranty granted by ST for such product.

ST and the ST logo are trademarks of ST. All other product or service names are the property of their respective owners.

Information in this document supersedes and replaces information previously supplied in any prior versions of this document.

© 2014 STMicroelectronics – All rights reserved

# AMEYA360

## Components Supply Platform

### Authorized Distribution Brand :



### Website :

Welcome to visit [www.ameya360.com](http://www.ameya360.com)

### Contact Us :

#### ➤ Address :

401 Building No.5, JiuGe Business Center, Lane 2301, Yishan Rd  
Minhang District, Shanghai , China

#### ➤ Sales :

Direct +86 (21) 6401-6692

Email [amall@ameya360.com](mailto:amall@ameya360.com)

QQ 800077892

Skype [ameyasales1](#) [ameyasales2](#)

#### ➤ Customer Service :

Email [service@ameya360.com](mailto:service@ameya360.com)

#### ➤ Partnership :

Tel +86 (21) 64016692-8333

Email [mkt@ameya360.com](mailto:mkt@ameya360.com)