

## ADVANCED 8-PIN LOAD-SHARE CONTROLLER

### FEATURES

- High Accuracy, Better Than 1% CurrentShare Error at Full Load
- High-Side or Low-Side (GND Reference) Current-Sense Capability
- Ultra-Low Offset Current Sense Amplifier
- Single Wire Load Share Bus
- Full Scale Adjustability
- Intel® SSI LoadShare Specification Compliant
- Disconnect from Load Share Bus at Stand-By
- Load Share Bus Protection Against Shorts to GND or to the Supply Rail
- 8-Pin MSOP Package Minimizes Space
- Lead-Free Assembly

### SYSTEM CONFIGURATIONS

- Modules With Remote Sense Capability
- Modules With Adjust Input
- Modules With Both Remote Sense and Adjust Input
- In Conjunction With the Internal Feedback E/A of OEM Power Supply Units

### DESCRIPTION

The UCC39002 is an advanced, high performance and low cost loadshare controller that provides all necessary functions to parallel multiple independent power supplies or dc-to-dc modules. Targeted for high reliability applications in server, workstation, telecom and other distributed power systems, the controller is suitable for N+1 redundant systems or high current applications where off-the-shelf power supplies need to be paralleled.

The BiCMOS UCC39002 is based on the automatic master/slave architecture of the UC3902 and UC3907 load share controllers. It provides better than 1% current share error between modules at full load by using a very low offset post-package-trimmed current-sense amplifier and a high-gain negative feedback loop. And with the amplifier's common mode range of 0-V to the supply rail, the current sense resistor,  $R_{SHUNT}$ , can be placed in either the GND return path or in the positive output rail of the power supply.

### TYPICAL LOW-SIDE CURRENT SENSING APPLICATION

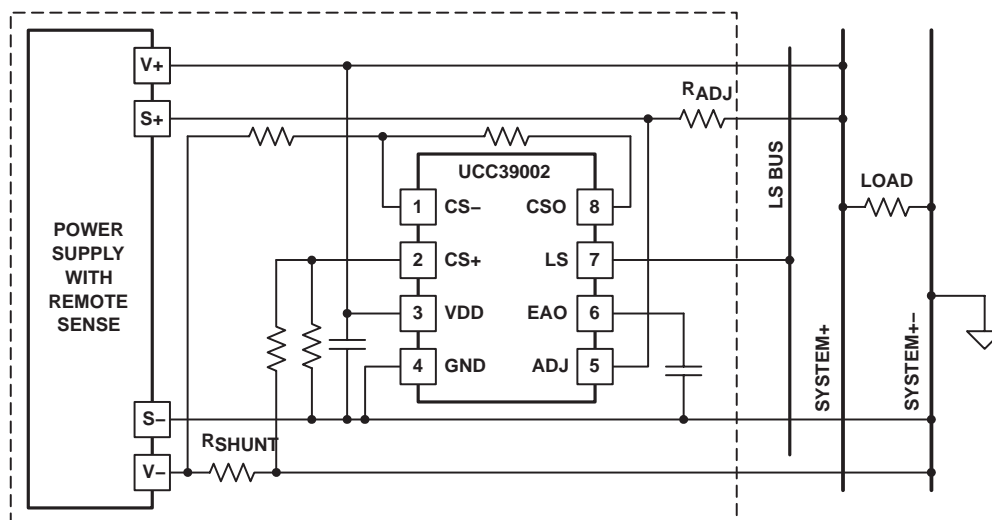

**UCC29002**  
**UCC29002/1**  
**UCC39002**

SLUS495H – SEPTEMBER 2001 – REVISED AUGUST 2007

**DESCRIPTION (continued)**

The functionality of the UCC29002/1 differs slightly compared to the UCC39002. The UCC39002 will force the maximum adjustment range at start up to quickly engage load sharing; the UCC29002/1 ADJ amplifier will operate in a linear mode during start up, resulting in a more gradual load sharing at turn on.

During transient conditions while adding or removing power supplies, the UCC39002 protects the system by keeping the load share bus disconnected from the remaining supplies. By disabling the adjust function in case a short of the load share bus occurs to either GND or the supply rail, it also provides protection for the system against erroneous output voltage adjustment.

The UCC39002 also meets Intel's SSI (Server System Infrastructure) loadshare specifications of a single-line load share bus and scalable load share voltage for any level of output currents.

The UCC39002 family is offered in 8-pin MSOP (DGK), SOIC (D), and PDIP (P) packages.

**absolute maximum ratings over operating free-air temperature (unless otherwise noted)<sup>†§</sup>**

Supply voltage, current limited ( $V_{DD}$ )	.....	-0.3 V to 15 V
Supply voltage, voltage source ( $V_{DD}$ )	.....	-0.3 V to 13.5 V
Input voltage, current sense amplifier ( $V_{CS+}$ , $V_{CS-}$ )	.....	-0.3 V to $V_{DD} + 0.3$ V
Current sense amplifier output voltage ( $V_{CSO}$ )	.....	-0.3 V to $V_{DD}$
Load share bus voltage ( $V_{LS}$ )	.....	-0.3 V to $V_{DD}$
Supply current ( $I_{DD} + I_{ZENER}$ )	.....	10 mA
Adjust pin input voltage ( $V_{ADJ}$ )	.....	$V_{EAO} + 1$ V < $V_{ADJ} \leq V_{DD}$
Adjust pin sink current ( $I_{ADJ}$ )	.....	6 mA
Operating junction temperature range, $T_J$	.....	-55°C to 150°C
Storage temperature range $T_{stg}$	.....	-65°C to 150°C
Lead Temperature, $T_{sol}$ (Soldering, 10 seconds)	.....	300°C

<sup>†</sup> Stresses beyond those listed under "absolute maximum ratings" may cause permanent damage to the device. These are stress ratings only, and functional operation of the device at these or any other conditions beyond those indicated under "recommended operating conditions" is not implied. Exposure to absolute-maximum-rated conditions for extended periods may affect device reliability.

<sup>§</sup> All voltages are with respect to GND. Currents are positive into, negative out of the specified terminal.

**SOIC (D) OR MSOP (DGK) PACKAGE  
(TOP VIEW)**

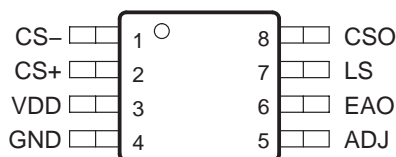

**PDIP (P) PACKAGE  
(TOP VIEW)**

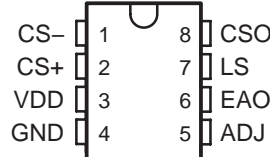

**AVAILABLE OPTIONS**

$T_A = T_J$	PACKAGED DEVICES		
	SOIC-8 (D) <sup>†</sup>	MSOP-8 (DGK) <sup>†</sup>	PDIP-8 (P)
-40°C to 105°C	UCC29002D	UCC29002DGK	UCC29002P
	UCC29002D/1	UCC29002DGK/1	NA
0°C to 70°C	UCC39002D	UCC39002DGK	UCC39002P

<sup>†</sup> The D and DGK packages are available taped and reeled. Add R suffix to device type (e.g. UCC39002DR) to order quantities of 2,500 devices per reel.

electrical characteristics  $V_{DD} = 12\text{ V}$ ,  $0^\circ\text{C} < T_A < 70^\circ\text{C}$  for the UCC39002,  $-40^\circ\text{C} < T_A < 105^\circ\text{C}$  for the UCC29002 and UCC29002/1,  $T_A = T_J$  (unless otherwise noted)

### general

PARAMETER	TEST CONDITIONS	MIN	TYP	MAX	UNITS
Supply current	LS with no load, ADJ = 5 V		2.5	3.5	mA
VDD clamp voltage	IDD = 6 mA	13.50	14.25	15.00	V

### undervoltage lockout

PARAMETER	TEST CONDITIONS	MIN	TYP	MAX	UNITS
Start-up voltage <sup>(1)</sup>		4.175	4.375	4.575	V
Hysteresis		0.200	0.375	0.550	

### current sense amplifier

PARAMETER	TEST CONDITIONS	MIN	TYP	MAX	UNITS	
$V_{IO}$	Input offset voltage	$T_A = 25^\circ\text{C}$ $V_{CSO} = 5\text{ V}$ $V_{IC} = 0.5\text{ V}$ or $11.5\text{ V}$ ,	-100	100	$\mu\text{V}$	
					Over-temperature variation	$\pm 10$
$A_V$	Gain	75	90		dB	
CMRR	Common mode rejection ratio	75	90			
$I_{BIAS}$	Input bias current (CS+, CS-)	-0.6		0.6	$\mu\text{A}$	
$V_{OH}$	High-level output voltage (CSO)	$0.1\text{ V} \leq ([CS+] - [CS-]) \leq 0.4\text{ V}$ , $I_{OUT\_CSO} = 0\text{ mA}$	10.7	11.0	11.8	V
$V_{OL}$	Low-level output voltage (CSO)	$-0.4\text{ V} \leq ([CS+] - [CS-]) \leq 0.1\text{ V}$ , $I_{OUT\_CSO} = 0\text{ mA}$	0.00	0.10	0.15	
$I_{OH}$	High-level output current (CSO)	$V_{CSO} = 10\text{ V}$	-1	-1.5		mA
$I_{OL}$	Low-level output current (CSO)	$V_{CSO} = 1\text{ V}$	1	1.5		
GBW	Gain bandwidth product <sup>(2)</sup>		2		MHz	

### load share driver (LS)

PARAMETER	TEST CONDITIONS	MIN	TYP	MAX	UNITS	
$V_{RANGE}$	Input voltage range	0		10	V	
$V_{OUT}$	Output voltage	$V_{CSO} = 1\text{ V}$	0.995	1		1.005
		$V_{CSO} = 10\text{ V}$	9.995	10		10.005
$V_{OL}$	Low-level output voltage	$V_{CSO} = 0\text{ V}$ , $I_{OUT\_LS} = 0\text{ mA}$	0.00	0.10		0.15
$V_{OH}$	High-level output voltage <sup>(2)</sup>		$V_{DD} - 1.7$			
$I_{OUT}$	Output current	$0.5\text{ V} \leq V_{LS} \leq 10\text{ V}$	-1	-1.5	mA	
$I_{SC}$	Short circuit current	$V_{LS} = 0\text{ V}$ , $V_{CSO} = 10\text{ V}$	-10	-20		
$V_{SHTDN}$	Driver shutdown threshold	$V_{CS-} - V_{CS+}$	0.3	0.5	0.7	V

### load share bus protection

PARAMETER	TEST CONDITIONS	MIN	TYP	MAX	UNITS	
$I_{ADJ}$	Adjust amplifier current	$V_{CSO} = 2\text{ V}$ , $V_{EAO} = 2\text{ V}$ , $V_{LS} = V_{DD}$ , $V_{ADJ} = 5\text{ V}$	0	5	10	$\mu\text{A}$
		$V_{CSO} = 2\text{ V}$ , $V_{EAO} = 2\text{ V}$ , $V_{LS} = 0\text{ V}$ , $V_{ADJ} = 5\text{ V}$	0	5	10	

(1) Enables the load share bus at start-up.

(2) Ensured by design. Not production tested.

**UCC29002**  
**UCC29002/1**  
**UCC39002**

SLUS495H – SEPTEMBER 2001 – REVISED AUGUST 2007

electrical characteristics  $V_{DD} = 12\text{ V}$ ,  $0^\circ\text{C} < T_A < 70^\circ\text{C}$  for the UCC39002,  $-40^\circ\text{C} < T_A < 105^\circ\text{C}$  for the UCC29002 and UCC29002/1,  $T_A = T_J$  (unless otherwise noted) (continued)

**error amplifier**

PARAMETER		TEST CONDITIONS	MIN	TYP	MAX	UNITS
$V_{OH}$	High-level output voltage	$I_{OUT\_EAO} = 0\text{ mA}$	3.50	3.65	3.80	V
$g_M$	Transconductance	$I_{EAO} = \pm 50\ \mu\text{A}$		14		mS
$I_{OH}$	High-level output current	$V_{LS} - V_{CSO} = 0.4\text{ V}$ , $V_{REAO} = 2.2\text{ k}\Omega$	0.70	0.85	1.00	mA

**ADJ buffer**

PARAMETER		TEST CONDITIONS	MIN	TYP	MAX	UNITS		
$V_{IO}$	Input offset voltage <sup>(2)</sup>	$V_{ADJ} = 1.5\text{ V}$ , $V_{EAO} = 0\text{ V}$ ,		-60		mV		
$I_{SINK}$	Sink current	$V_{ADJ} = 5.0\text{ V}$ , $V_{EAO} = 0\text{ V}$	0	5	10	$\mu\text{A}$		
$I_{SINK}$	Sink current	$T_A = 25^\circ\text{C}$		3.60	3.95	4.30	mA	
		$0^\circ\text{C} \leq T_A \leq 70^\circ\text{C}$	$V_{ADJ} = 5.0\text{ V}$ , $LS = \text{floating}$	$V_{EAO} = 2.0\text{ V}$	3.45	3.95		4.45
		$-40^\circ\text{C} \leq T_A \leq 105^\circ\text{C}$			3.35	3.95		4.55

- (1) Enables the load share bus at start-up.  
(2) Ensured by design. Not production tested.

**TERMINAL FUNCTIONS**

TERMINAL		I/O	DESCRIPTION
NAME	NO.		
ADJ	5	O	Adjust amplifier output. This is the buffered output of the error amplifier block to adjust output voltage of the power supply being controlled. This pin must always be connected to a voltage equal to or greater than $V_{EAO} + 1\text{ V}$ .
CS-	1	I	Current sense amplifier inverting input.
CS+	2	I	Current sense amplifier non-inverting input.
CSO	8	O	Current sense amplifier output.
EAO	6	O	Output for load share error amplifier. (Transconductance error amplifier.)
GND	4	-	Ground. Reference ground and power ground for all device functions. Return the device to the low current sense- path of the converter.
LS	7	I/O	Load share bus. Output of the load share bus driver amplifier.
VDD	3	I	Power supply providing bias to the device. Bypass with a good quality, low ESL 0.1- $\mu\text{F}$ to 1- $\mu\text{F}$ , maximum, capacitor as close to the VDD pin and GND as possible.

typical high-side current sensing application

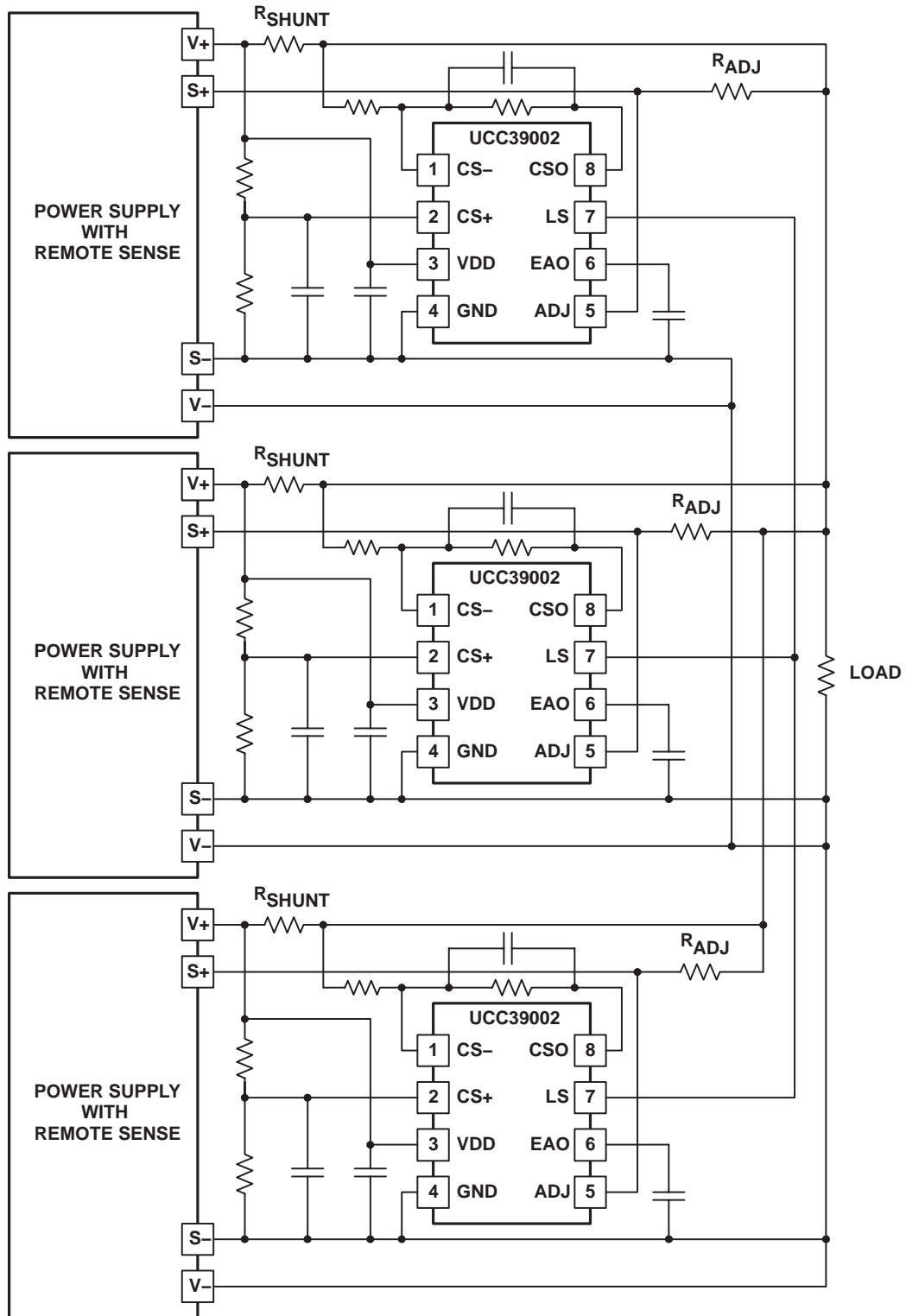

**UCC29002**  
**UCC29002/1**  
**UCC39002**

SLUS495H – SEPTEMBER 2001 – REVISED AUGUST 2007

**functional block diagram**

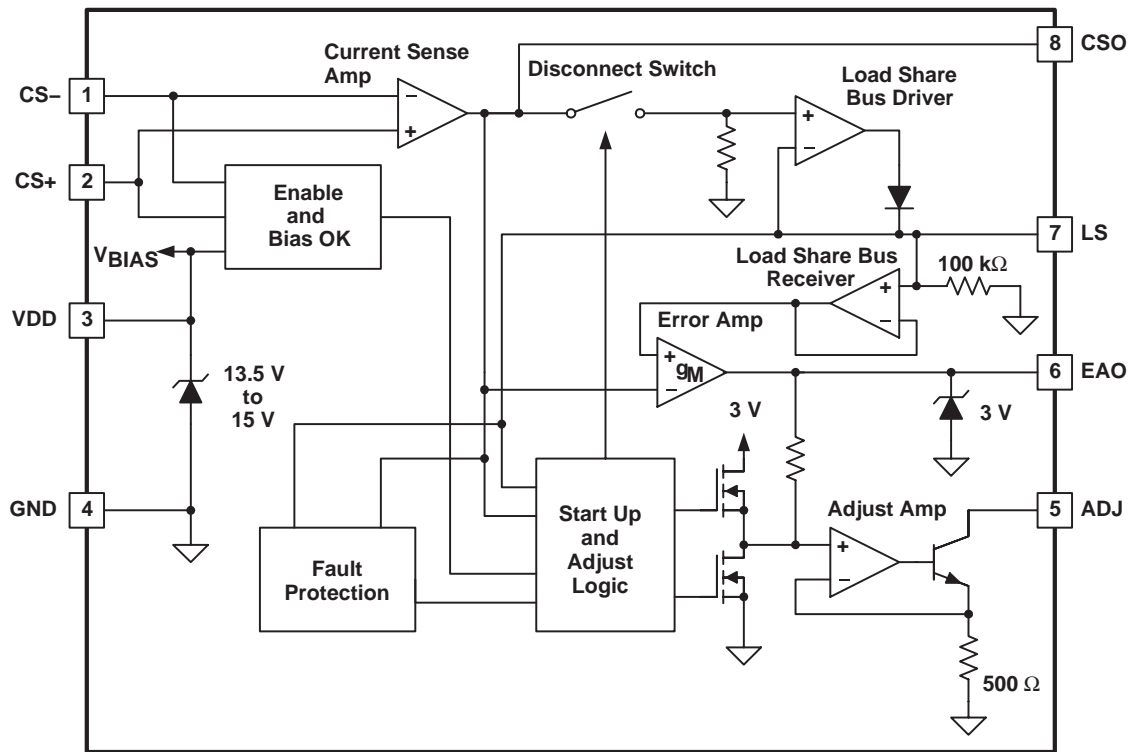

UDG-02086

## FUNCTIONAL DESCRIPTION

### differential current sense amplifier (CS+, CS–, CSO)

The UCC39002 features a high-gain and high-precision amplifier to measure the voltage across a low-value current sense resistor. Since the amplifier is fully uncommitted, the current sense gain is user programmable. The extremely low input offset voltage of the UCC39002 current sense amplifier makes it suitable to measure current information across a low value sense resistor. Furthermore, the input common mode range includes ground and the positive supply rail of the UCC39002 ( $V_{DD}$ ). Accordingly, the current sense resistor can be placed in the ground return path or in the positive output rail of the power supply  $V_O$  as long as  $V_O \leq V_{DD}$ . The current sense amplifier is not unity gain stable and must have a minimum gain of three.

### load share bus driver amplifier (CSO)

This is a unity-gain buffer amplifier to provide separation between the load share bus voltage and the output of the current sense amplifier. The circuit implements an ideal diode with virtually 0 V forward voltage drop by placing the diode inside the feedback loop of the amplifier. The diode function is used to automatically establish the role of the master module in the system. The UCC39002 which is assigned to be the master uses the load share bus driver amplifier to copy its output current information on to the load share bus.

All slave units, with lower output current levels by definition, have this “ideal diode” reversed biased ( $V_{CSO} < V_{LS}$ ). Consequently, the  $V_{CSO}$  and  $V_{LS}$  signals will be separated. That allows the error amplifier of the UCC39002 to compare its respective module’s output current to the master module’s output current and make the necessary corrections to achieve a balanced current distribution.

Since the bus is always driven by a single load share bus driver amplifier, the number of modules ( $n$ ) are limited by the output current capability of the amplifier according to:

$$n = \frac{100 \text{ k}\Omega \times I_{OUT,MIN}}{V_{LS,FULL\_SCALE}} \quad (1)$$

where 100 k $\Omega$  is the input impedance of the LS pin as shown in the block diagram,  $I_{OUT,MIN}$  is given in the data sheet and  $V_{LS,FULL\_SCALE}$  is the maximum voltage on the load share bus at full load.

Note that the number of parallel units can be increased by reducing the full scale bus voltage, i.e. by reducing the current sense gain.

### load share bus receiver amplifier (LS)

The load share bus receiver amplifier is a unity gain buffer monitoring the load share bus voltage. Its primary purpose is to ensure that the load share bus is not loaded by the internal impedances of the UCC39002. The LS pin is already internally compensated and has an internal 15-kHz filter. Adding external capacitance, including stray capacitance, should be avoided to maintain stability.

## FUNCTIONAL DESCRIPTION

### error amplifier (EAO)

As pictured in the block diagram, the UCC39002 employs a transconductance also called  $g_M$  type error amplifier. The  $g_M$  amplifier was chosen because it requires only one pin, the output to be accessible for compensation.

The purpose of the error amplifier is to compare the average, per module current level to the output current of the respective module controlled by the UCC39002. It is accommodated by connecting the buffered  $V_{LS}$  voltage to its non-inverting input and the  $V_{CSO}$  signal to its inverting input. If the average per module current, represented by the load share bus is higher than the module's own output current, an error signal will be developed across the compensation components connected between the EAO pin and ground. The error signal is then used by the adjust amplifier to make the necessary output voltage adjustments to ensure equal output currents among the parallel operated power supplies.

In case the UCC39002 assumes the role of the master load share controller in the system or it is used in conjunction with a stand alone power module, the measured current signal on  $V_{CSO}$  is approximately equal to the  $V_{LS}$  voltage. To avoid erroneous output voltage adjustment, the input of the error amplifier incorporates a typically 25 mV offset to ensure that the inverting input of the error amplifier is biased higher than the non-inverting input. Consequently, when the two signals are equal, there will be no adjustment made and the initial output voltage set point is maintained.

### adjust amplifier output (ADJ)

A current proportional to the error voltage  $V_{EAO}$  on pin 6 is sunk by the ADJ pin. This current flows through the adjust resistor  $R_{ADJ}$  and changes the output voltage of the module controlled by the UCC39002. The amplitude of the current is set by the 500- $\Omega$  internal resistor between ground and the emitter of the amplifier's open collector output transistor according to Figure 1. The adjust current value is given as:

$$I_{ADJ} = \frac{V_{EAO}}{500 \Omega} \quad (2)$$

At the master module  $V_{EAO}$  is 0 V, thus the adjust current must be zero as well. This ensures that the output voltage of the master module remains at its initial output voltage set point at all times.

Furthermore, at insufficient bias level, during a fault or when the UCC39002 is disabled, the non-inverting input of the adjust amplifier is pulled to ground to prevent erroneous adjustment of the module's output voltage by the load share controller.



## FUNCTIONAL DESCRIPTION

### enable function (CS+, CS-)

The two inputs of the current sense amplifier are also used for implementing an ENABLE function. During normal operation  $CS^- = CS^+$  and the internal offset added between the  $CS^-$  voltage and the inverting input of the enable comparator ensures that the UCC39002 is always enabled. By forcing the  $CS^-$  pin approximately 0.5-V above the  $CS^+$  pin, the UCC39002 can be forced into a disable mode. While disabled, the UCC39002 disconnects itself from the load share bus and its adjust current is zero.

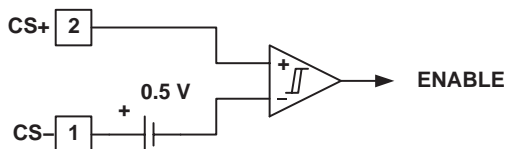

UDG-02087

**Figure 1. Enable Comparator**

### fault protection

Accidentally, the load share bus might be shorted to ground or to the positive bias voltage of the UCC39002. These events might result in erroneous output voltage adjustment. For that reason, the load share bus is continuously monitored by a window comparator as shown in Figure 2.

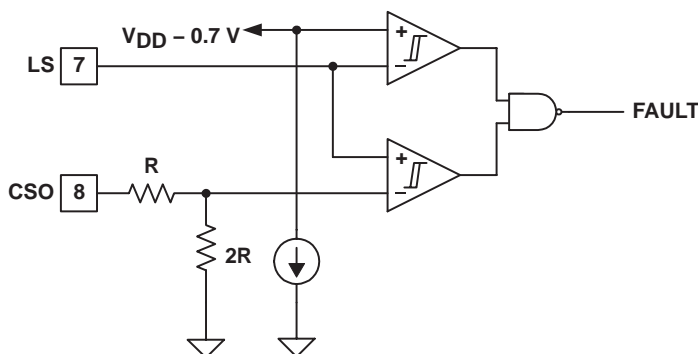

UDG-02088

**Figure 2. Fault Protection Comparators**

The FAULT signal is handled by the start up and adjust logic which pulls the non-inverting input of the adjust amplifier low when the FAULT signal is asserted.

## FUNCTIONAL DESCRIPTION

### start up and adjust logic

The start up and adjust logic responds to unusual operating conditions during start up, fault and disable. Under these circumstances the information obtainable by the error amplifier of the UCC39002 is not sufficient to make the right output voltage adjustment, therefore the adjust amplifier is forced to certain known states. Similarly, the driver amplifier of UCC39002 is disabled during these conditions.

In the UCC39002/UCC29002, during start up, the load share driver amplifier is disabled by the disconnect switch and the adjust amplifier is forced to sink the maximum current through the adjust resistor. This operating mode ensures that the module controlled by the UCC39002 will be able to quickly engage in sharing the load current since its output will be adjusted to a sufficiently high voltage immediately at turn on. Both the load share driver and the adjust amplifiers revert to normal operation as soon as the measured current exceeds 80% of the average per module current level represented by the LS bus voltage. The UCC29002/1 does not have this logic at start up. In this way, the UCC29002/1 will not adjust the output of the module to its maximum adjustment range at turn on and engages load sharing at more moderate rate.

In case of a fault shorting the load share bus to ground or to the bias of the UCC39002 the load share bus driver and the adjust amplifiers are disabled. The same action takes place when the UCC39002 is disabled using the CS+ and CS– pins or when the bias voltage is below the minimum operating voltage.

### bias and bias OK circuit (VDD)

The UCC39002 is built on a 15-V, high performance BiCMOS process. Accordingly the maximum voltage across the V<sub>DD</sub> and GND pins (pin 3 and 4 respectively) is limited to 15 V. The recommended maximum operating voltage is 13.5 V which corresponds to the tolerance of the on-board 14.2-V Zener clamp circuit. In case the bias voltage could exceed the 13.5-V limit, the UCC39002 should be powered through a current limiting resistor. The current into the V<sub>DD</sub> pin must be limited to 10 mA as listed in the absolute maximum ratings table.

The bypass capacitor for VDD is also the compensation for the input active clamp of the device and, as such, must be placed as close to the device pins (VDD and GND) as possible, using a good quality low ESL capacitor, including trace length. The device is optimized for a capacitor value of 0.1 μF to 1 μF.

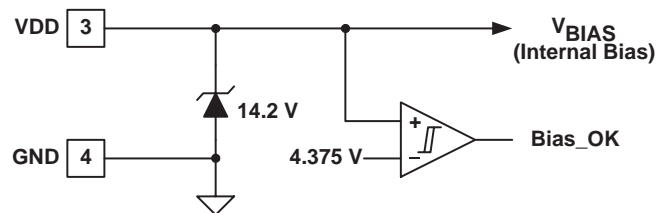

UDG-02089

Figure 3. V<sub>DD</sub> Clamp and Bias Monitor

## FUNCTIONAL DESCRIPTION

The UCC39002 does not have an undervoltage lockout circuit. The bias OK comparator works as an enable function with a 4.375-V threshold. While  $V_{DD} < 4.375\text{ V}$  the load share control functions are disabled. While this might be inconvenient for some low voltage applications it is necessary to ensure high accuracy. The load share accuracy is dependent on working with relatively large signal amplitudes on the load share bus. If the internal offsets, current sense error and ground potential difference between the UCC39002 controllers are comparable in amplitude to the load share bus voltage, they can cause significant current distribution error in the system. The maximum voltage on the load share bus is limited approximately 1.7-V below the bias voltage level ( $V_{DD}$ ) which would result in an unacceptably low load share bus amplitude therefore poor accuracy at low  $V_{DD}$  levels. To circumvent this potential design problem, the UCC39002 won't operate below the above mentioned 4.375-V bias voltage threshold. If the system does not have a suitable bias voltage available to power the UCC39002, it is recommended to use an inexpensive charge pump which can generate the bias voltage for all the UCC39002s in the load share system.

The maximum  $V_{DD}$  of the UCC39002 is 15 V. For higher-voltage applications, use the application solution as recommended in Figure 4. A Zener clamp on the VDD pin is provided internally so the device can be powered from higher voltage rails using a minimum number of external components.

The CSA inputs must be adjusted so as to not exceed their absolute maximum voltage ratings.

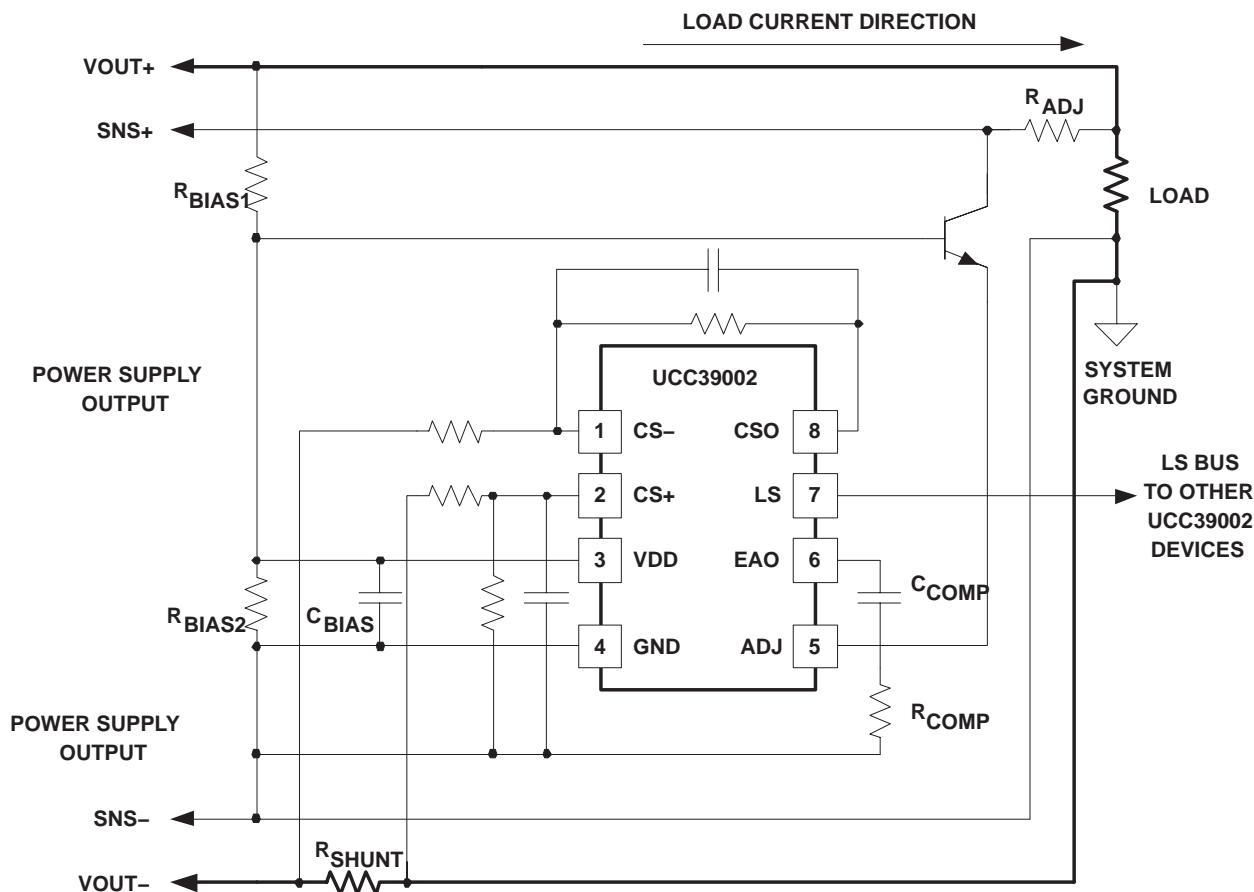

Figure 4. High Voltage Application

**DESIGN PROCEDURE**

The following is a practical step-by-step design procedure on how to use the UCC39002 to parallel power modules for load sharing.

**paralleling the power modules**

- $V_{OUT}$  = nominal output voltage of the modules to be paralleled
- $I_{OUT(max)}$  = maximum output current of each module to be paralleled
- $\Delta V_{ADJ}$  = maximum output voltage adjustment range of the power modules to be paralleled
- N = number of modules

**NOTE:** The power modules to be paralleled must be equipped with true remote sense or access to the feedback divider of the module's error amplifier.

A typical high side application for a single module is shown in Figure 5 and is repeated for each module to be paralleled.

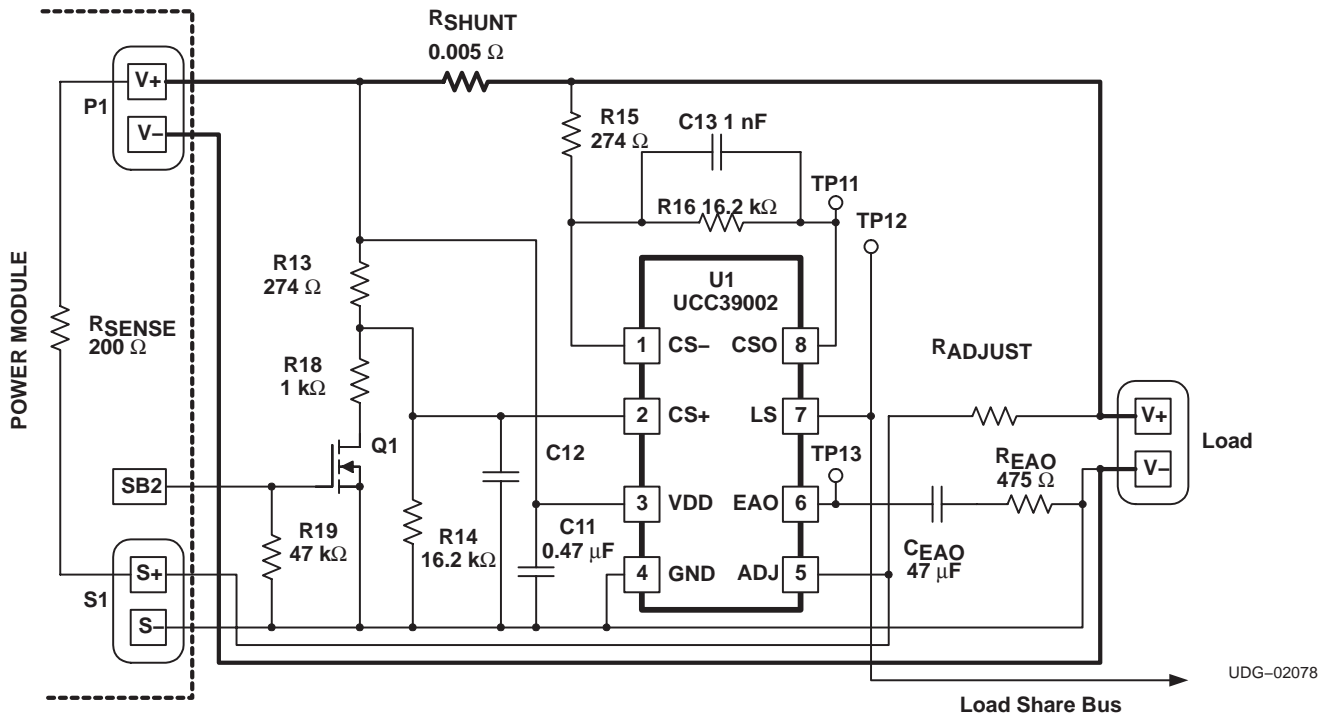

**Figure 5. Typical High-Side Application for Single Power Module**

In Figure 5, P1 represents the output voltage terminals of the module, S1 represents the remote sense terminals of the module, and a signal on the SB2 terminal will enable the disconnect feature of the device. The load share bus is the common bus between all of the paralleled load share controllers. VDD must be decoupled with a good quality ceramic capacitor returned directly to GND.

DESIGN PROCEDURE

measuring the modules' loop

Using the configuration in Figure 6, measure the unity gain crossover frequency of the power modules to be paralleled. A typical resultant bode plot is shown in Figure 7.

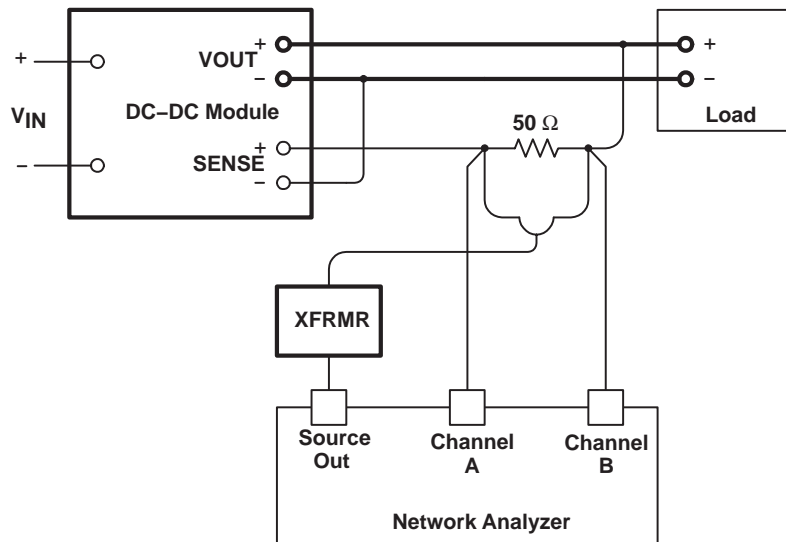

UDG-02079

Figure 6. Unity Gain Crossover Frequency Measurement Connection Diagram

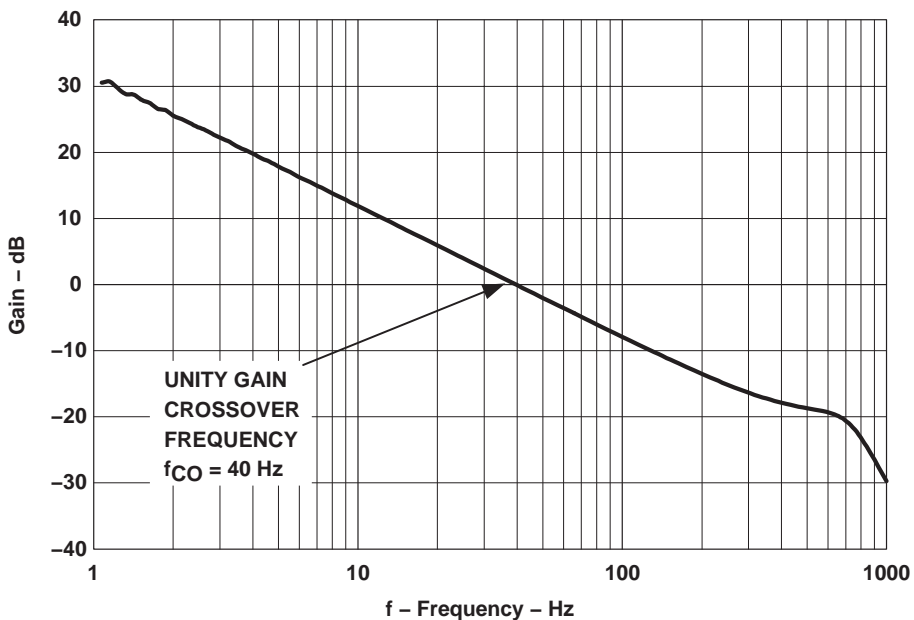

Figure 7. Power Module Bode Plot

## DESIGN PROCEDURE

### the shunt resistor

Selection of the shunt resistor is limited by its voltage drop at maximum module output current. This voltage drop should be much less than the voltage adjustment range of the module:

$$I_{OUT(max)} \times R_{SHUNT} \ll \Delta V_{ADJ(max)} \quad (3)$$

Other limitations for the sense resistor are the desired minimum power dissipation and available component ratings.

### the CSA gain

The gain of the current sense amplifier is configured by the compensation components between Pin 1, CS–, and Pin 8, CSO, of the load share device. The voltage at the CSO pin is limited by the saturation voltage of the internal current sense amplifier and must be at least two volts less than VDD:

$$V_{CSO(max)} < VDD - 2 V \quad (4)$$

The maximum current sense amplifier gain is equal to:

$$A_{CSA} = \frac{V_{CSO}}{(R_{SHUNT} \times I_{OUT(max)})} \quad (5)$$

Referring to Figure 5, the gain is equal to R16/R15 and a high-frequency pole, configured with C13, is used for noise filtering. This impedance is mirrored at the CS+ pin of the differential amplifier as shown.

The current sense amplifier output voltage,  $V_{CSO}$ , serves as the input to the unity gain LS bus driver. The module with the highest output voltage forward biases the internal diode at the output of the LS bus driver and determine the voltage on the load share bus,  $V_{LS}$ . The other modules act as slaves and represent a load on the  $I_{VDD}$  of the module due to the internal 100-k $\Omega$  resistor at the LS pin. This increase in supply current for the master module is equal to  $N(V_{LS}/100 \text{ k}\Omega)$ .

## DESIGN PROCEDURE

### determining R<sub>ADJUST</sub>

The Sense+ terminal of the module is connected to the ADJ pin of the load-share controller. By placing a resistor between this ADJ pin and the load, an artificial Sense+ voltage is created from the voltage drop across R<sub>ADJUST</sub> due to the current sunk by the internal NPN transistor. The voltage at the ADJ pin must be maintained at approximately 1 V above the voltage at the EAO pin. This is necessary in order to keep the transistor at the output of the internal adjust amplifier from saturating. To fulfill this requirement, R<sub>ADJUST</sub> is first calculated using the following equation:

$$R_{ADJUST} \geq \frac{(\Delta V_{ADJ(max)} - I_{OUT(max)} \times R_{SHUNT}) \times 500 \Omega}{\left[ V_{OUT} - \Delta V_{ADJ(max)} - 1 V - \left( \frac{\Delta V_{ADJ(max)}}{R_{SENSE}} \times 500 \Omega \right) \right]} \quad (6)$$

Where R<sub>SHUNT</sub> is the current sense resistor, and R<sub>SENSE</sub> is the internal resistance between V<sub>OUT+</sub> and SENSE+ within the module.

Also needed for consideration is the actual adjust pin current. The maximum sink current for the ADJ pin, I<sub>ADJmax</sub>, is 6 mA as determined by the internal 500-Ω emitter resistor and 3-V clamp. The value of adjust resistor, R<sub>ADJUST</sub>, is based upon the maximum adjustment range of the module, ΔV<sub>ADJmax</sub>. This adjust resistor is determined using the following formula:

$$R_{ADJUST} \geq \frac{[\Delta V_{ADJ(max)} - I_{OUT(max)} \times R_{SHUNT}]}{I_{ADJ(max)} - \frac{\Delta V_{ADJ(max)}}{R_{SENSE}}} \quad (7)$$

By selecting a resistor that meets both of these minimum requirements, the ADJ pin will be at least 1 V greater than the EAO voltage and the adjust pin sink current will not exceed its 6 mA maximum.

## DESIGN PROCEDURE

### error amplifier compensation

The total load-share loop unity-gain crossover frequency,  $f_{CO}$ , should be set at least one decade below the measured crossover frequency of the paralleled modules previously measured,  $f_{CO(\text{module})}$ . (See Figure 7) Compensation of the transconductance error amplifier is accomplished by placing the compensation resistor,  $R_{EAO}$ , and capacitor,  $C_{EAO}$ , between EAO and GND. The values of these components is determined using equations (8) and (13).

$$C_{EAO} = \left( \frac{g_M}{2\pi f_{CO}} \right) (A_{CSA}) (A_V) (A_{ADJ}) (|A_{PWR}(f_{CO})|) \quad (8)$$

Where:

- $g_M$  is the transconductance of the error amplifier, typically 14 mS,
- $f_{CO}$  is equal to the desired crossover frequency in Hz of the load share loop, typically  $f_{CO}(\text{module})/10$ ,
- $A_{CSA}$  is the CSA gain,
- $A_V$  is the voltage gain,
- $A_{ADJ}$  is the gain associated with the adjust amplifier,
- $|A_{PWR}(f_{CO})|$  is the measured gain of the power module at the desired load share crossover frequency,  $f_{CO}$ , converted to V/V from dB

$$A_{CSA} = \frac{R_{16}}{R_{15}} \quad (9)$$

$$A_V = \frac{R_{SHUNT}}{R_{LOAD}}, R_{LOAD} = \frac{V_{OUT}}{I_{OUT(\text{max})}} \quad (10)$$

$$A_{ADJ} = \frac{R_{ADJUST} \times R_{SENSE}}{(R_{ADJUST} + R_{SENSE}) \times 500 \Omega} \quad (11)$$

$$|A_{PWR}(f_{CO})| = 10 \left( \frac{G_{MODULE}(f_{CO})}{20} \right) \quad (12)$$

Where  $G_{MODULE}(f_{CO})$  is the measured value of the gain from Figure 7, at the desired crossover frequency.

Once the  $C_{EAO}$  capacitor is determined,  $R_{EAO}$  is selected to achieve the desired loop response:

$$R_{EAO} = \sqrt{\left( \frac{1}{g_M \times |A_{PWR}(f_{CO})| \times A_V \times A_{CSA} \times A_{ADJ}} \right)^2 - \left( \frac{1}{2\pi (f_{CO}) (C_{EAO})} \right)^2} \quad (13)$$



## DESIGN PROCEDURE

### references

For further details, refer to the following document:

- Reference Design, *48-V<sub>IN</sub>, 12-V<sub>OUT</sub> Loadshare System Using UCC39002 with Three DC/DC PH-100S4 Modules*, Texas Instruments Literature No. SLUA270

For a more complete description of general load sharing topics, refer to the following documents.

- Application Note, *The UC3902 Load Share Controller and Its Performance in Distributed Power Systems*, TI Literature No. SLUA128
- Application Note, *UC3907 Load Share IC Simplifies Parallel Power Supply Design*, TI Literature No. SLUA147

**PACKAGING INFORMATION**

Orderable Device	Status (1)	Package Type	Package Drawing	Pins	Package Qty	Eco Plan (2)	Lead/Ball Finish (6)	MSL Peak Temp (3)	Op Temp (°C)	Device Marking (4/5)	Samples
UCC29002D	ACTIVE	SOIC	D	8	75	Green (RoHS & no Sb/Br)	CU NIPDAU	Level-1-260C-UNLIM	-40 to 105	29002	<a href="#">Samples</a>
UCC29002D/1	ACTIVE	SOIC	D	8	75	Green (RoHS & no Sb/Br)	CU NIPDAU	Level-1-260C-UNLIM	-40 to 105	290021	<a href="#">Samples</a>
UCC29002D/1G4	ACTIVE	SOIC	D	8	75	Green (RoHS & no Sb/Br)	CU NIPDAU	Level-1-260C-UNLIM	-40 to 105	290021	<a href="#">Samples</a>
UCC29002DG4	ACTIVE	SOIC	D	8	75	Green (RoHS & no Sb/Br)	CU NIPDAU	Level-1-260C-UNLIM	-40 to 105	29002	<a href="#">Samples</a>
UCC29002DGK	ACTIVE	VSSOP	DGK	8	80	Green (RoHS & no Sb/Br)	CU NIPDAUAG	Level-2-260C-1 YEAR	-40 to 105	29002	<a href="#">Samples</a>
UCC29002DGKG4	ACTIVE	VSSOP	DGK	8	80	Green (RoHS & no Sb/Br)	CU NIPDAUAG	Level-2-260C-1 YEAR	-40 to 105	29002	<a href="#">Samples</a>
UCC29002DGKR	ACTIVE	VSSOP	DGK	8	2500	Green (RoHS & no Sb/Br)	CU NIPDAUAG	Level-2-260C-1 YEAR	-40 to 105	29002	<a href="#">Samples</a>
UCC29002DR	ACTIVE	SOIC	D	8	2500	Green (RoHS & no Sb/Br)	CU NIPDAU	Level-1-260C-UNLIM	-40 to 105	29002	<a href="#">Samples</a>
UCC29002DR/1	ACTIVE	SOIC	D	8	2500	Green (RoHS & no Sb/Br)	CU NIPDAU	Level-1-260C-UNLIM	-40 to 105	290021	<a href="#">Samples</a>
UCC29002P	ACTIVE	PDIP	P	8	50	Pb-Free (RoHS)	CU NIPDAU	N / A for Pkg Type	-40 to 105	UCC29002P	<a href="#">Samples</a>
UCC39002D	ACTIVE	SOIC	D	8	75	Green (RoHS & no Sb/Br)	CU NIPDAU	Level-1-260C-UNLIM	0 to 70	39002	<a href="#">Samples</a>
UCC39002DG4	ACTIVE	SOIC	D	8	75	Green (RoHS & no Sb/Br)	CU NIPDAU	Level-1-260C-UNLIM	0 to 70	39002	<a href="#">Samples</a>
UCC39002DGK	ACTIVE	VSSOP	DGK	8	80	Green (RoHS & no Sb/Br)	CU NIPDAUAG	Level-2-260C-1 YEAR	0 to 70	39002	<a href="#">Samples</a>
UCC39002DGKR	ACTIVE	VSSOP	DGK	8	2500	Green (RoHS & no Sb/Br)	CU NIPDAUAG	Level-2-260C-1 YEAR	0 to 70	39002	<a href="#">Samples</a>
UCC39002DR	ACTIVE	SOIC	D	8	2500	Green (RoHS & no Sb/Br)	CU NIPDAU	Level-1-260C-UNLIM	0 to 70	39002	<a href="#">Samples</a>
UCC39002DRG4	ACTIVE	SOIC	D	8	2500	Green (RoHS & no Sb/Br)	CU NIPDAU	Level-1-260C-UNLIM	0 to 70	39002	<a href="#">Samples</a>
UCC39002P	ACTIVE	PDIP	P	8	50	Pb-Free (RoHS)	CU NIPDAU	N / A for Pkg Type	0 to 70	UCC39002P	<a href="#">Samples</a>

(1) The marketing status values are defined as follows:

**ACTIVE:** Product device recommended for new designs.

**LIFEBUY:** TI has announced that the device will be discontinued, and a lifetime-buy period is in effect.

**NRND:** Not recommended for new designs. Device is in production to support existing customers, but TI does not recommend using this part in a new design.

**PREVIEW:** Device has been announced but is not in production. Samples may or may not be available.

**OBSOLETE:** TI has discontinued the production of the device.

(2) Eco Plan - The planned eco-friendly classification: Pb-Free (RoHS), Pb-Free (RoHS Exempt), or Green (RoHS & no Sb/Br) - please check <http://www.ti.com/productcontent> for the latest availability information and additional product content details.

**TBD:** The Pb-Free/Green conversion plan has not been defined.

**Pb-Free (RoHS):** TI's terms "Lead-Free" or "Pb-Free" mean semiconductor products that are compatible with the current RoHS requirements for all 6 substances, including the requirement that lead not exceed 0.1% by weight in homogeneous materials. Where designed to be soldered at high temperatures, TI Pb-Free products are suitable for use in specified lead-free processes.

**Pb-Free (RoHS Exempt):** This component has a RoHS exemption for either 1) lead-based flip-chip solder bumps used between the die and package, or 2) lead-based die adhesive used between the die and leadframe. The component is otherwise considered Pb-Free (RoHS compatible) as defined above.

**Green (RoHS & no Sb/Br):** TI defines "Green" to mean Pb-Free (RoHS compatible), and free of Bromine (Br) and Antimony (Sb) based flame retardants (Br or Sb do not exceed 0.1% by weight in homogeneous material)

(3) MSL, Peak Temp. - The Moisture Sensitivity Level rating according to the JEDEC industry standard classifications, and peak solder temperature.

(4) There may be additional marking, which relates to the logo, the lot trace code information, or the environmental category on the device.

(5) Multiple Device Markings will be inside parentheses. Only one Device Marking contained in parentheses and separated by a "~" will appear on a device. If a line is indented then it is a continuation of the previous line and the two combined represent the entire Device Marking for that device.

(6) Lead/Ball Finish - Orderable Devices may have multiple material finish options. Finish options are separated by a vertical ruled line. Lead/Ball Finish values may wrap to two lines if the finish value exceeds the maximum column width.

**Important Information and Disclaimer:** The information provided on this page represents TI's knowledge and belief as of the date that it is provided. TI bases its knowledge and belief on information provided by third parties, and makes no representation or warranty as to the accuracy of such information. Efforts are underway to better integrate information from third parties. TI has taken and continues to take reasonable steps to provide representative and accurate information but may not have conducted destructive testing or chemical analysis on incoming materials and chemicals. TI and TI suppliers consider certain information to be proprietary, and thus CAS numbers and other limited information may not be available for release.

In no event shall TI's liability arising out of such information exceed the total purchase price of the TI part(s) at issue in this document sold by TI to Customer on an annual basis.

**TAPE AND REEL INFORMATION**

**QUADRANT ASSIGNMENTS FOR PIN 1 ORIENTATION IN TAPE**

\*All dimensions are nominal

Device	Package Type	Package Drawing	Pins	SPQ	Reel Diameter (mm)	Reel Width W1 (mm)	A0 (mm)	B0 (mm)	K0 (mm)	P1 (mm)	W (mm)	Pin1 Quadrant
UCC29002DGKR	VSSOP	DGK	8	2500	330.0	12.4	5.3	3.4	1.4	8.0	12.0	Q1
UCC29002DR	SOIC	D	8	2500	330.0	12.4	6.4	5.2	2.1	8.0	12.0	Q1
UCC29002DR/1	SOIC	D	8	2500	330.0	12.4	6.4	5.2	2.1	8.0	12.0	Q1
UCC39002DGKR	VSSOP	DGK	8	2500	330.0	12.4	5.3	3.4	1.4	8.0	12.0	Q1
UCC39002DR	SOIC	D	8	2500	330.0	12.4	6.4	5.2	2.1	8.0	12.0	Q1

## TAPE AND REEL BOX DIMENSIONS



\*All dimensions are nominal

Device	Package Type	Package Drawing	Pins	SPQ	Length (mm)	Width (mm)	Height (mm)
UCC29002DGKR	VSSOP	DGK	8	2500	366.0	364.0	50.0
UCC29002DR	SOIC	D	8	2500	367.0	367.0	35.0
UCC29002DR/1	SOIC	D	8	2500	367.0	367.0	35.0
UCC39002DGKR	VSSOP	DGK	8	2500	366.0	364.0	50.0
UCC39002DR	SOIC	D	8	2500	340.5	338.1	20.6

P (R-PDIP-T8)

PLASTIC DUAL-IN-LINE PACKAGE



- NOTES:
- A. All linear dimensions are in inches (millimeters).
  - B. This drawing is subject to change without notice.
  - C. Falls within JEDEC MS-001 variation BA.

DGK (S-PDSO-G8)

PLASTIC SMALL-OUTLINE PACKAGE

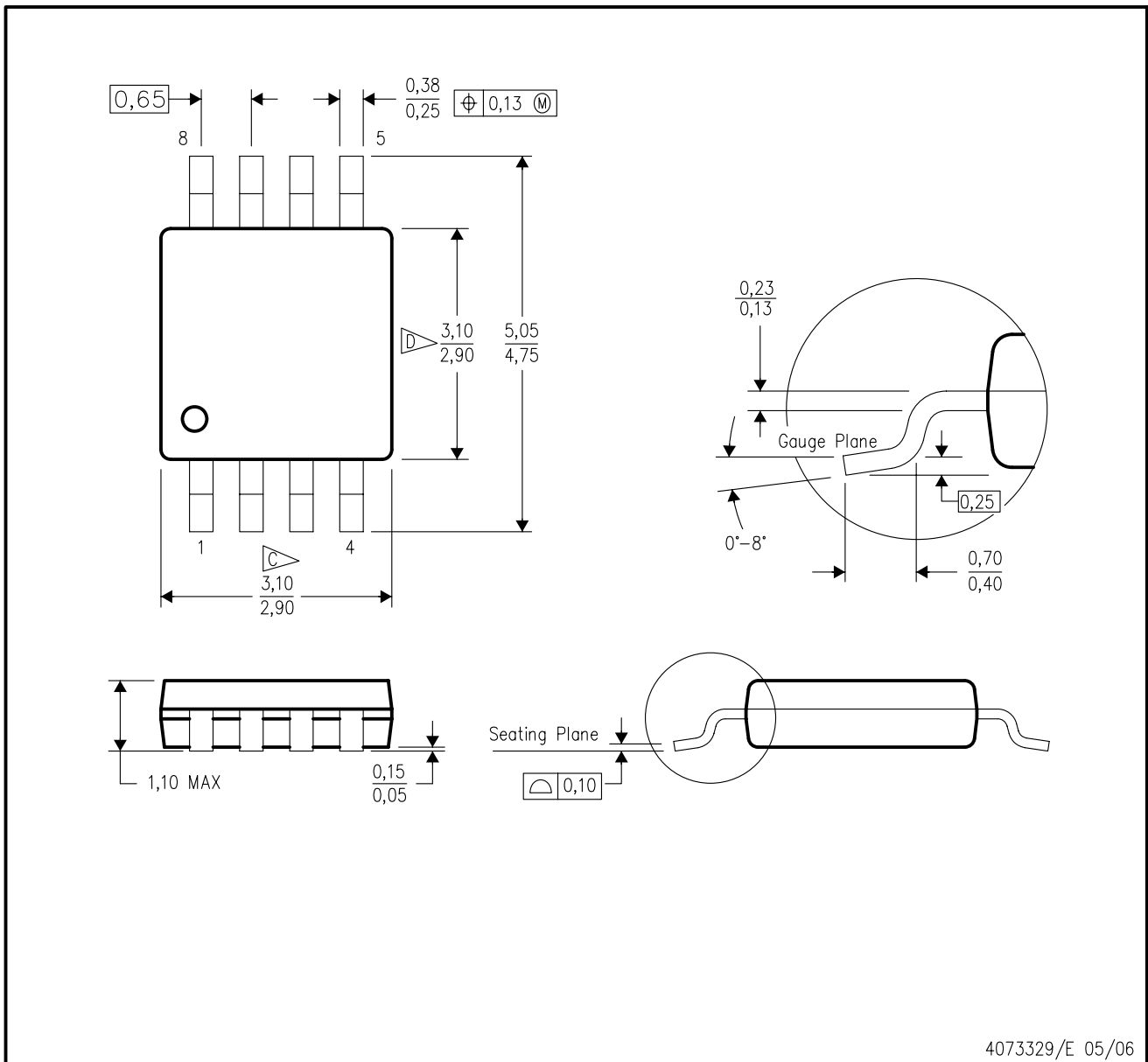

- NOTES:
- A. All linear dimensions are in millimeters.
  - B. This drawing is subject to change without notice.
  - C. Body length does not include mold flash, protrusions, or gate burrs. Mold flash, protrusions, or gate burrs shall not exceed 0.15 per end.
  - D. Body width does not include interlead flash. Interlead flash shall not exceed 0.50 per side.
  - E. Falls within JEDEC MO-187 variation AA, except interlead flash.



- NOTES:
- A. All linear dimensions are in millimeters.
  - B. This drawing is subject to change without notice.
  - C. Publication IPC-7351 is recommended for alternate designs.
  - D. Laser cutting apertures with trapezoidal walls and also rounding corners will offer better paste release. Customers should contact their board assembly site for stencil design recommendations. Refer to IPC-7525 for other stencil recommendations.
  - E. Customers should contact their board fabrication site for solder mask tolerances between and around signal pads.



D (R-PDSO-G8)

PLASTIC SMALL OUTLINE

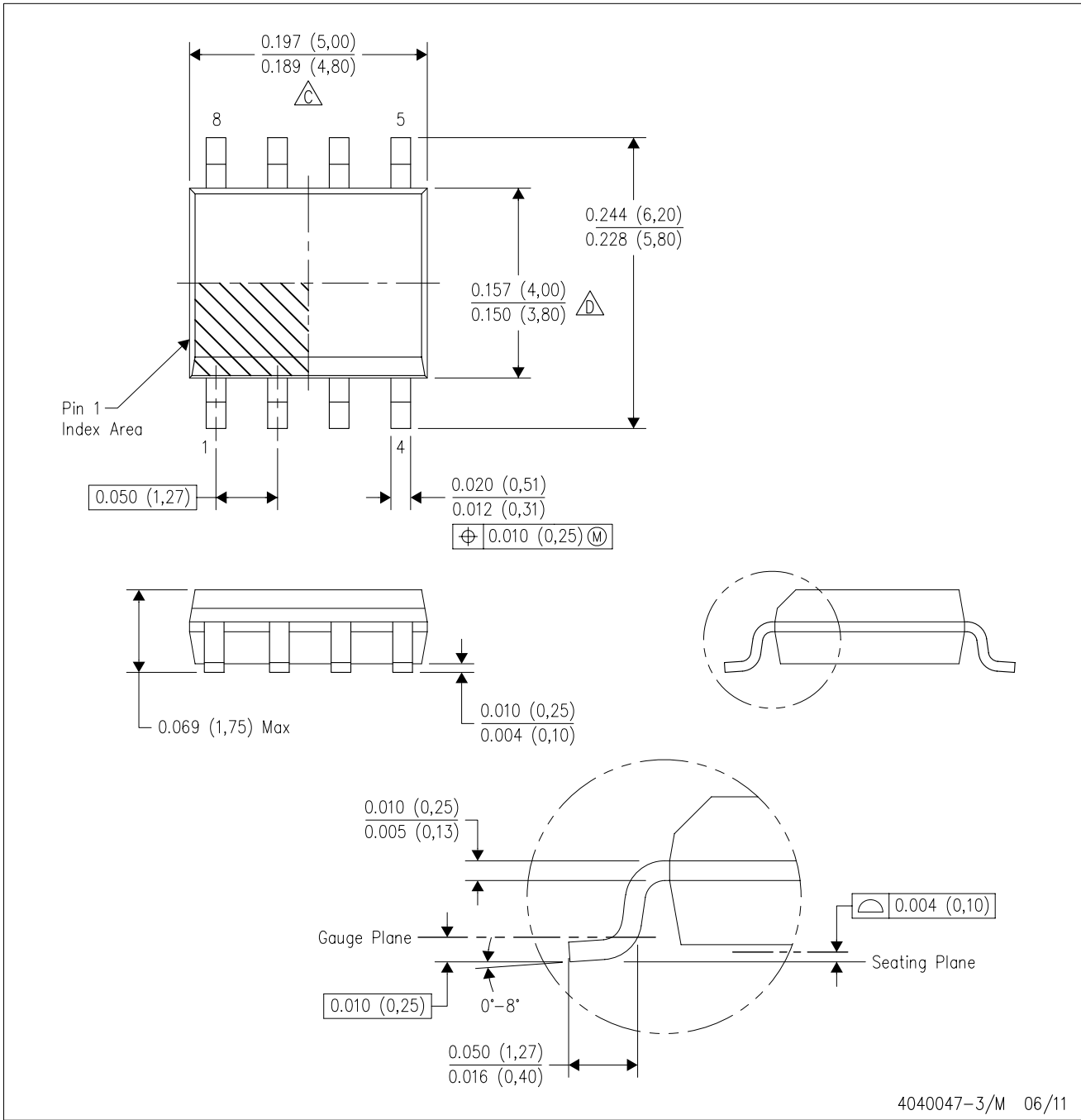

4040047-3/M 06/11

- NOTES:
- A. All linear dimensions are in inches (millimeters).
  - B. This drawing is subject to change without notice.
  - C. Body length does not include mold flash, protrusions, or gate burrs. Mold flash, protrusions, or gate burrs shall not exceed 0.006 (0,15) each side.
  - D. Body width does not include interlead flash. Interlead flash shall not exceed 0.017 (0,43) each side.
  - E. Reference JEDEC MS-012 variation AA.

D (R-PDSO-G8)

PLASTIC SMALL OUTLINE



- NOTES:
- A. All linear dimensions are in millimeters.
  - B. This drawing is subject to change without notice.
  - C. Publication IPC-7351 is recommended for alternate designs.
  - D. Laser cutting apertures with trapezoidal walls and also rounding corners will offer better paste release. Customers should contact their board assembly site for stencil design recommendations. Refer to IPC-7525 for other stencil recommendations.
  - E. Customers should contact their board fabrication site for solder mask tolerances between and around signal pads.

## IMPORTANT NOTICE

Texas Instruments Incorporated and its subsidiaries (TI) reserve the right to make corrections, enhancements, improvements and other changes to its semiconductor products and services per JESD46, latest issue, and to discontinue any product or service per JESD48, latest issue. Buyers should obtain the latest relevant information before placing orders and should verify that such information is current and complete. All semiconductor products (also referred to herein as "components") are sold subject to TI's terms and conditions of sale supplied at the time of order acknowledgment.

TI warrants performance of its components to the specifications applicable at the time of sale, in accordance with the warranty in TI's terms and conditions of sale of semiconductor products. Testing and other quality control techniques are used to the extent TI deems necessary to support this warranty. Except where mandated by applicable law, testing of all parameters of each component is not necessarily performed.

TI assumes no liability for applications assistance or the design of Buyers' products. Buyers are responsible for their products and applications using TI components. To minimize the risks associated with Buyers' products and applications, Buyers should provide adequate design and operating safeguards.

TI does not warrant or represent that any license, either express or implied, is granted under any patent right, copyright, mask work right, or other intellectual property right relating to any combination, machine, or process in which TI components or services are used. Information published by TI regarding third-party products or services does not constitute a license to use such products or services or a warranty or endorsement thereof. Use of such information may require a license from a third party under the patents or other intellectual property of the third party, or a license from TI under the patents or other intellectual property of TI.

Reproduction of significant portions of TI information in TI data books or data sheets is permissible only if reproduction is without alteration and is accompanied by all associated warranties, conditions, limitations, and notices. TI is not responsible or liable for such altered documentation. Information of third parties may be subject to additional restrictions.

Resale of TI components or services with statements different from or beyond the parameters stated by TI for that component or service voids all express and any implied warranties for the associated TI component or service and is an unfair and deceptive business practice. TI is not responsible or liable for any such statements.

Buyer acknowledges and agrees that it is solely responsible for compliance with all legal, regulatory and safety-related requirements concerning its products, and any use of TI components in its applications, notwithstanding any applications-related information or support that may be provided by TI. Buyer represents and agrees that it has all the necessary expertise to create and implement safeguards which anticipate dangerous consequences of failures, monitor failures and their consequences, lessen the likelihood of failures that might cause harm and take appropriate remedial actions. Buyer will fully indemnify TI and its representatives against any damages arising out of the use of any TI components in safety-critical applications.

In some cases, TI components may be promoted specifically to facilitate safety-related applications. With such components, TI's goal is to help enable customers to design and create their own end-product solutions that meet applicable functional safety standards and requirements. Nonetheless, such components are subject to these terms.

No TI components are authorized for use in FDA Class III (or similar life-critical medical equipment) unless authorized officers of the parties have executed a special agreement specifically governing such use.

Only those TI components which TI has specifically designated as military grade or "enhanced plastic" are designed and intended for use in military/aerospace applications or environments. Buyer acknowledges and agrees that any military or aerospace use of TI components which have **not** been so designated is solely at the Buyer's risk, and that Buyer is solely responsible for compliance with all legal and regulatory requirements in connection with such use.

TI has specifically designated certain components as meeting ISO/TS16949 requirements, mainly for automotive use. In any case of use of non-designated products, TI will not be responsible for any failure to meet ISO/TS16949.

### Products

Audio	<a href="http://www.ti.com/audio">www.ti.com/audio</a>
Amplifiers	<a href="http://amplifier.ti.com">amplifier.ti.com</a>
Data Converters	<a href="http://dataconverter.ti.com">dataconverter.ti.com</a>
DLP® Products	<a href="http://www.dlp.com">www.dlp.com</a>
DSP	<a href="http://dsp.ti.com">dsp.ti.com</a>
Clocks and Timers	<a href="http://www.ti.com/clocks">www.ti.com/clocks</a>
Interface	<a href="http://interface.ti.com">interface.ti.com</a>
Logic	<a href="http://logic.ti.com">logic.ti.com</a>
Power Mgmt	<a href="http://power.ti.com">power.ti.com</a>
Microcontrollers	<a href="http://microcontroller.ti.com">microcontroller.ti.com</a>
RFID	<a href="http://www.ti-rfid.com">www.ti-rfid.com</a>
OMAP Applications Processors	<a href="http://www.ti.com/omap">www.ti.com/omap</a>
Wireless Connectivity	<a href="http://www.ti.com/wirelessconnectivity">www.ti.com/wirelessconnectivity</a>

### Applications

Automotive and Transportation	<a href="http://www.ti.com/automotive">www.ti.com/automotive</a>
Communications and Telecom	<a href="http://www.ti.com/communications">www.ti.com/communications</a>
Computers and Peripherals	<a href="http://www.ti.com/computers">www.ti.com/computers</a>
Consumer Electronics	<a href="http://www.ti.com/consumer-apps">www.ti.com/consumer-apps</a>
Energy and Lighting	<a href="http://www.ti.com/energy">www.ti.com/energy</a>
Industrial	<a href="http://www.ti.com/industrial">www.ti.com/industrial</a>
Medical	<a href="http://www.ti.com/medical">www.ti.com/medical</a>
Security	<a href="http://www.ti.com/security">www.ti.com/security</a>
Space, Avionics and Defense	<a href="http://www.ti.com/space-avionics-defense">www.ti.com/space-avionics-defense</a>
Video and Imaging	<a href="http://www.ti.com/video">www.ti.com/video</a>

### TI E2E Community

[e2e.ti.com](http://e2e.ti.com)

# AMEYA360

## Components Supply Platform

Authorized Distribution Brand :



Website :

Welcome to visit [www.ameya360.com](http://www.ameya360.com)

Contact Us :

➤ Address :

401 Building No.5, JiuGe Business Center, Lane 2301, Yishan Rd  
Minhang District, Shanghai , China

➤ Sales :

Direct +86 (21) 6401-6692

Email [amall@ameya360.com](mailto:amall@ameya360.com)

QQ 800077892

Skype [ameyasales1](#) [ameyasales2](#)

➤ Customer Service :

Email [service@ameya360.com](mailto:service@ameya360.com)

➤ Partnership :

Tel +86 (21) 64016692-8333

Email [mkt@ameya360.com](mailto:mkt@ameya360.com)