

FEATURES

- Overshoot and Undershoot Voltage Protection
- Specified Break-Before-Make Switching
- Low ON-State Resistance (10 Ω)
- Control Inputs Are 5-V Tolerant
- Low Charge Injection
- Excellent ON-Resistance Matching
- Low Total Harmonic Distortion (THD)
- 1.8-V to 5.5-V Single-Supply Operation
- Latch-Up Performance Exceeds 100 mA Per JESD 78, Class II
- ESD Performance Tested Per JESD 22
 - 2000-V Human-Body Model (A114-B, Class II)
 - 1000-V Charged-Device Model (C101)
 - 300-V Machine Model (A115-A)

APPLICATIONS

- Sample-and-Hold Circuit
- Battery-Powered Equipments
- Audio and Video Signal Routing
- Communication Circuits

DESCRIPTION/ORDERING INFORMATION

The TS5A623157 is a dual single-pole, double-throw (SPDT) analog switch designed to operate from 1.65 V to 5.5 V. This device can handle both digital and analog signals. Signals up to V+ (peak) can be transmitted in either direction.

The TS5A623157 senses overshoot and undershoot events at the I/Os and responds by preventing voltage differentials from developing and turning the switch on.

ORDERING INFORMATION

T _A	PACKAGE ⁽¹⁾⁽²⁾		ORDERABLE PART NUMBER	TOP-SIDE MARKING
–40°C to 85°C	VSSOP (MSOP-10) – DGS	Tape and reel	TS5A623157DGSR	35R
	QFN – RSE	Tape and reel	TS5A623157RSER	PREVIEW

(1) Package drawings, thermal data, and symbolization are available at www.ti.com/packaging.

(2) For the most current package and ordering information, see the Package Option Addendum at the end of this document, or see the TI website at www.ti.com.

FUNCTION TABLE

IN	NC TO COM, COM TO NC	NO TO COM, COM TO NO
L	ON	OFF
H	OFF	ON

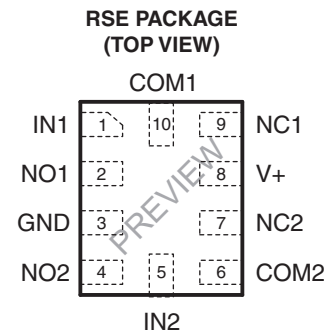
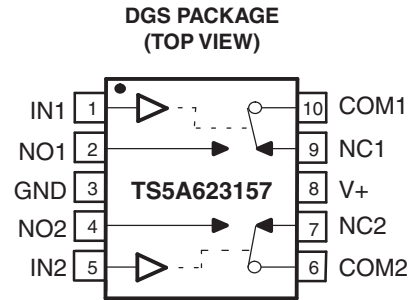

PRODUCT PREVIEW



Please be aware that an important notice concerning availability, standard warranty, and use in critical applications of Texas Instruments semiconductor products and disclaimers thereto appears at the end of this data sheet.

TS5A623157
DUAL 10-Ω SPDT ANALOG SWITCH
WITH UNDERSHOOT/OVERSHOOT VOLTAGE PROTECTION

SCDS253–SEPTEMBER 2007

SUMMARY OF CHARACTERISTICS
 $V_+ = 5\text{ V}$, $T_A = 25^\circ\text{C}$

Configuration	2:1 multiplexer/demultiplexer (1 × SPDT)
Number of channels	2
ON-state resistance (r_{on})	10 Ω
ON-state resistance match (Δr_{on})	0.15 Ω
ON-state resistance flatness ($r_{on(flat)}$)	2 Ω
Turn-on/turn-off time (t_{ON}/t_{OFF})	5 ns / 3.4 ns
Break-before-make time (t_{BBM})	0.5 ns
Charge injection (Q_C)	5 pC
Bandwidth (BW)	371 MHz
OFF isolation (O_{ISO})	-61 dB at 10 MHz
Crosstalk (X_{TALK})	-61 dB at 10 MHz
Total harmonic distortion (THD)	0.06%
Leakage current ($I_{NO(OFF)}/I_{NC(OFF)}$)	±1 μA
Power-supply current (I_+)	1.2 μA
Undershoot protection	-2 V
Overshoot protection	$V_+ + 2\text{ V}$
Package options	10-pin VSSOP (DGS), 10-pin QFN (RSE)

Absolute Minimum and Maximum Ratings⁽¹⁾⁽²⁾

over operating free-air temperature range (unless otherwise noted)

		MIN	MAX	UNIT
V_+	Supply voltage range ⁽³⁾	-0.5	6.5	V
V_{NC} V_{NO} V_{COM}	Analog voltage range ⁽³⁾⁽⁴⁾⁽⁵⁾	-0.5	$V_+ + 0.5$	V
$I_{I/OK}$	Analog port diode current	$V_+ < V_{NC}, V_{NO}, V_{COM} < 0$		±50 mA
I_{NC} I_{NO} I_{COM}	On-state switch current	$V_{NC}, V_{NO}, V_{COM} = 0 \text{ to } V_+$		±50 mA
V_{IN}	Digital input voltage range ⁽³⁾⁽⁴⁾	-0.5	6.5	V
I_{IK}	Digital input clamp current	$V_I < 0$		-50 mA
I_+ I_{GND}	Continuous current through V_+ or GND			±100 mA
T_{stg}	Storage temperature range	-65	150	°C

- (1) Stresses beyond those listed under "absolute maximum ratings" may cause permanent damage to the device. These are stress ratings only, and functional operation of the device at these or any other conditions beyond those indicated under "recommended operating conditions" is not implied. Exposure to absolute-maximum-rated conditions for extended periods may affect device reliability.
- (2) The algebraic convention, whereby the most negative value is a minimum and the most positive value is a maximum.
- (3) All voltages are with respect to ground, unless otherwise specified.
- (4) The input and output voltage ratings may be exceeded if the input and output clamp-current ratings are observed.
- (5) This value is limited to 5.5 V maximum.

Package Thermal Impedance

			UNIT
θ_{JA}	Package thermal impedance ⁽¹⁾	DGS package	165
		RSE package	243

- (1) The package thermal impedance is calculated in accordance with JESD 51-7.

PRODUCT PREVIEW

Electrical Characteristics for 5-V Supply
 $V_+ = 4.5\text{ V to }5.5\text{ V}$, $T_A = -40^\circ\text{C to }85^\circ\text{C}$ (unless otherwise noted)

PARAMETER	SYMBOL	TEST CONDITIONS	T_A	V_+	MIN	TYP	MAX	UNIT	
Analog Switch									
Analog signal range	V_{COM}, V_{NO}, V_{NC}				0		V_+	V	
Voltage undershoot	V_{IKU}	$0 \geq (I_{NC}, I_{NO}, \text{ or } I_{COM}) \geq -50\text{ mA}$		5.5 V			-2	V	
Peak ON-state resistance	r_{peak}	$0 \leq (V_{NO} \text{ or } V_{NC}) \leq V_+$, $I_{COM} = -30\text{ mA}$, Switch ON, See Figure 14	25°C	4.5 V		4.6	11	Ω	
			Full				13		
ON-state resistance	r_{on}	$V_{NO} \text{ or } V_{NC} = 0$, $I_{COM} = 30\text{ mA}$ Switch ON, See Figure 14	25°C	4.5 V		4	6.5	Ω	
			Full				8		
			25°C				4		8
			Full				10		
			25°C				5.5		10
			Full				12		
ON-state resistance match between channels	Δr_{on}	$V_{NO} \text{ or } V_{NC} = 3.15\text{ V}$, $I_{COM} = -30\text{ mA}$, Switch ON, See Figure 14	25°C	4.5 V		0.1	0.14	Ω	
			Full				0.15		
ON-state resistance flatness	$r_{on(Flat)}$	$0 \leq (V_{NO} \text{ or } V_{NC}) \leq V_+$, $I_{COM} = -30\text{ mA}$, Switch ON, See Figure 14	25°C	4.5 V		1.5	2	Ω	
			Full				4		
NC, NO OFF leakage current	$I_{NC(OFF)}, I_{NO(OFF)}$	$V_{NC} \text{ or } V_{NO} = 0 \text{ to } V_+$, $V_{COM} = V_+ \text{ to } 0$, Switch OFF, See Figure 15	25°C	5.5 V		1	20	nA	
			Full				150		
NC, NO ON leakage current	$I_{NC(ON)}, I_{NO(ON)}$	$V_{NC} \text{ or } V_{NO} = 0 \text{ to } V_+$, $V_{COM} = \text{Open}$, Switch ON, See Figure 16	25°C	5.5 V		1	20	nA	
			Full				150		
COM ON leakage current	$I_{COM(ON)}$	$V_{NC} \text{ or } V_{NO} = \text{Open}$, $V_{COM} = 0 \text{ to } V_+$, Switch ON, See Figure 16	25°C	5.5 V		1	20	nA	
			Full				150		
Digital Control Input (IN)									
Input logic high	V_{IH}		Full		$V_+ \times 0.7$		5.5	V	
Input logic low	V_{IL}		Full		0		$V_+ \times 0.3$	V	
Input leakage current	I_{IH}, I_{IL}	$V_I = 5.5\text{ V or }0$	25°C	5.5 V		0.1	10	nA	
			Full				30		

TS5A623157
DUAL 10-Ω SPDT ANALOG SWITCH
WITH UNDERSHOOT/OVERSHOOT VOLTAGE PROTECTION

SCDS253–SEPTEMBER 2007

Electrical Characteristics for 5-V Supply (continued)

$V_+ = 4.5\text{ V to }5.5\text{ V}$, $T_A = -40^\circ\text{C to }85^\circ\text{C}$ (unless otherwise noted)

PARAMETER	SYMBOL	TEST CONDITIONS	T_A	V_+	MIN	TYP	MAX	UNIT	
Dynamic									
Turn-on time	t_{ON}	$V_{COM} = V_+$ or GND, $R_L = 500\ \Omega$,	$C_L = 50\text{ pF}$, See Figure 17	25°C	5 V	1	3.5	5	ns
				Full	4.5 V to 5.5 V	1		6	
Turn-off time	t_{OFF}	$V_{COM} = V_+$ or GND, $R_L = 500\ \Omega$,	$C_L = 50\text{ pF}$, See Figure 17	25°C	5 V	1	2.8	3.4	ns
				Full	4.5 V to 5.5 V	1		3.8	
Output voltage during undershoot	V_{OUTU}	See Figure 24			2.5	$V_{OH} - 0.3$		V	
Output voltage during overshoot	V_{OUTO}	See Figure 24				$V_{OL} + 0.3$	2	V	
Break-before-make time	t_{BBM}	$V_{NC} = V_{NO} = V_+/2$, $R_L = 50\ \Omega$,	$C_L = 50\text{ pF}$, See Figure 18	25°C	5 V	0.5	5	12	ns
				Full	4.5 V to 5.5 V	0.5		14	
Charge injection	Q_C	$V_{GEN} = 0$, $R_{GEN} = 0$,	$C_L = 0.1\text{ nF}$, See Figure 22	25°C	5 V		110	pC	
NC, NO OFF capacitance	$C_{NC(OFF)}$, $C_{NO(OFF)}$	V_{NC} or $V_{NO} = V_+$ or GND, Switch OFF,	See Figure 16	25°C	5 V		5	pF	
NC, NO ON capacitance	$C_{NC(ON)}$, $C_{NO(ON)}$	V_{NC} or $V_{NO} = V_+$ or GND, Switch ON,	See Figure 16	25°C	5 V		14.5	pF	
COM ON capacitance	$C_{COM(ON)}$	$V_{COM} = V_+$ or GND, Switch ON,	See Figure 16	25°C	5 V		14.5	pF	
Digital input capacitance	C_I	$V_I = V_+$ or GND,	See Figure 16	25°C	5 V		3.5	pF	
Bandwidth	BW	$R_L = 50\ \Omega$, Switch ON,	See Figure 19	25°C	5 V		371	MHz	
OFF isolation	O_{ISO}	$R_L = 50\ \Omega$, $f = 10\text{ MHz}$,	Switch OFF, See Figure 20	25°C	5 V		-61	dB	
Crosstalk	X_{TALK}	$R_L = 50\ \Omega$, $f = 10\text{ MHz}$,	Switch ON, See Figure 21	25°C	5 V		-61	dB	
Total harmonic distortion	THD	$R_L = 600\ \Omega$, $C_L = 50\text{ pF}$,	$f = 20\text{ Hz to }20\text{ kHz}$, See Figure 23	25°C	5 V		0.06	%	
Supply									
Positive supply current	I_+	$V_I = V_+$ or GND,	Switch ON or OFF	25°C	5.5 V	0.01	0.15	μA	
				Full			1.2		

PRODUCT PREVIEW

Electrical Characteristics for 3.3-V Supply

$V_+ = 3\text{ V to }3.6\text{ V}$, $T_A = -40^\circ\text{C to }85^\circ\text{C}$ (unless otherwise noted)

PARAMETER	SYMBOL	TEST CONDITIONS	T_A	V_+	MIN	TYP	MAX	UNIT
Analog Switch								
Analog signal range	V_{COM}, V_{NO}, V_{NC}				0		V_+	V
Voltage undershoot	V_{IKU}	$0 \geq (I_{NC}, I_{NO}, \text{ or } I_{COM}) \geq -50\text{ mA}$		3.6 V				V
Peak ON-state resistance	r_{peak}	$0 \leq (V_{NO} \text{ or } V_{NC}) \leq V_+$, $I_{COM} = -24\text{ mA}$, Switch ON, See Figure 14	25°C	3 V		8.9	14	Ω
			Full				18	
ON-state resistance	r_{on}	$V_{NO} \text{ or } V_{NC} = 0$, $I_{COM} = 24\text{ mA}$	25°C	3 V		5.4	8	Ω
			Full				10	
		$V_{NO} \text{ or } V_{NC} = 3\text{ V}$, $I_{COM} = -24\text{ mA}$	25°C			7.4	12	
			Full				15	
ON-state resistance match between channels	Δr_{on}	$V_{NO} \text{ or } V_{NC} = 2.1\text{ V}$, $I_{COM} = -24\text{ mA}$, Switch ON, See Figure 14	25°C	3 V		0.1	0.2	Ω
			Full				0.2	
ON-state resistance flatness	$r_{on(flat)}$	$0 \leq (V_{NO} \text{ or } V_{NC}) \leq V_+$, $I_{COM} = -24\text{ mA}$, Switch ON, See Figure 14	25°C	3 V		2.8	4	Ω
			Full				7	
NC, NO OFF leakage current	$I_{NC(OFF)}, I_{NO(OFF)}$	$V_{NC} \text{ or } V_{NO} = 0 \text{ to } V_+$, $V_{COM} = V_+ \text{ to } 0$, Switch OFF, See Figure 15	25°C	3.6 V		0.5	10	nA
			Full				100	
NC, NO ON leakage current	$I_{NC(ON)}, I_{NO(ON)}$	$V_{NC} \text{ or } V_{NO} = 0 \text{ to } V_+$, $V_{COM} = \text{Open}$, Switch ON, See Figure 16	25°C	3.6 V		0.5	10	nA
			Full				100	
COM ON leakage current	$I_{COM(ON)}$	$V_{NC} \text{ or } V_{NO} = \text{Open}$, $V_{COM} = 0 \text{ to } V_+$, Switch ON, See Figure 16	25°C	3.6 V		0.5	10	nA
			Full				100	
Digital Control Input (IN)								
Input logic high	V_{IH}		Full		$V_+ \times 0.7$		5.5	V
Input logic low	V_{IL}		Full		0		$V_+ \times 0.3$	V
Input leakage current	I_{IH}, I_{IL}	$V_I = 5.5\text{ V or }0$	25°C	3.6 V		0.1	10	nA
			Full				20	

TS5A623157
DUAL 10-Ω SPDT ANALOG SWITCH
WITH UNDERSHOOT/OVERSHOOT VOLTAGE PROTECTION

SCDS253–SEPTEMBER 2007

Electrical Characteristics for 3.3-V Supply (continued)

$V_+ = 3\text{ V to }3.6\text{ V}$, $T_A = -40^\circ\text{C to }85^\circ\text{C}$ (unless otherwise noted)

PARAMETER	SYMBOL	TEST CONDITIONS	T_A	V_+	MIN	TYP	MAX	UNIT	
Dynamic									
Turn-on time	t_{ON}	$V_{COM} = V_+$ or GND, $R_L = 500\ \Omega$,	$C_L = 50\text{ pF}$, See Figure 17	25°C	3.3 V	1	4.7	9.0	ns
				Full	3 V to 3.6 V	1		10.0	
Turn-off time	t_{OFF}	$V_{COM} = V_+$ or GND, $R_L = 500\ \Omega$,	$C_L = 50\text{ pF}$, See Figure 17	25°C	3.3 V	1	3.2	6.3	ns
				Full	3 V to 3.6 V	1		7.0	
Output voltage during undershoot	V_{OUTU}	See Figure 24			2.5	$V_{OH} - 0.3$		V	
Output voltage during overshoot	V_{OUTO}	See Figure 24				$V_{OL} + 0.3$	2	V	
Break-before-make time	t_{BBM}	$V_{NC} = V_{NO} = V_+/2$, $R_L = 50\ \Omega$,	$C_L = 50\text{ pF}$, See Figure 18	25°C	3.3 V	0.5	7	17	ns
				Full	3 V to 3.6 V	0.5		19.5	
Charge injection	Q_C	$V_{GEN} = 0$, $R_{GEN} = 0$,	$C_L = 0.1\text{ nF}$, See Figure 22	25°C	3.3 V		75	pC	
NC, NO OFF capacitance	$C_{NC(OFF)}$, $C_{NO(OFF)}$	V_{NC} or $V_{NO} = V_+$ or GND, Switch OFF,	See Figure 16	25°C	3.3 V		5	pF	
NC, NO ON capacitance	$C_{NC(ON)}$, $C_{NO(ON)}$	V_{NC} or $V_{NO} = V_+$ or GND, Switch ON,	See Figure 16	25°C	3.3 V		14.5	pF	
COM ON capacitance	$C_{COM(ON)}$	$V_{COM} = V_+$ or GND, Switch ON,	See Figure 16	25°C	3.3 V		14.5	pF	
Digital input capacitance	C_I	$V_I = V_+$ or GND,	See Figure 16	25°C	3.3 V		3.5	pF	
Bandwidth	BW	$R_L = 50\ \Omega$, Switch ON,	See Figure 19	25°C	3.3 V		370	MHz	
OFF isolation	O_{ISO}	$R_L = 50\ \Omega$, $f = 10\text{ MHz}$,	Switch OFF, See Figure 20	25°C	3.3 V		-60	dB	
Crosstalk	X_{TALK}	$R_L = 50\ \Omega$, $f = 10\text{ MHz}$,	Switch ON, See Figure 21	25°C	3.3 V		-60	dB	
Total harmonic distortion	THD	$R_L = 600\ \Omega$, $C_L = 50\text{ pF}$,	$f = 20\text{ Hz to }20\text{ kHz}$, See Figure 23	25°C	3.3 V		0.1	%	
Supply									
Positive supply current	I_+	$V_I = V_+$ or GND,	Switch ON or OFF	25°C	3.6 V		0.05	0.5	μA
				Full				0.75	

PRODUCT PREVIEW

Electrical Characteristics for 2.5-V Supply
 $V_+ = 2.3 \text{ V to } 2.7 \text{ V}$, $T_A = -40^\circ\text{C to } 85^\circ\text{C}$ (unless otherwise noted)

PARAMETER	SYMBOL	TEST CONDITIONS	T_A	V_+	MIN	TYP	MAX	UNIT	
Analog Switch									
Analog signal range	V_{COM}, V_{NO}, V_{NC}				0		V_+	V	
Voltage undershoot	V_{IKU}	$0 \text{ mA} \geq (I_{NC}, I_{NO}, \text{ or } I_{COM}) \geq -50 \text{ mA}$		2.7 V				V	
Peak ON-state resistance	r_{peak}	$0 \leq (V_{NO} \text{ or } V_{NC}) \leq V_+$, $I_{COM} = -8 \text{ mA}$, Switch ON, See Figure 14	25°C	2.3 V		13.9	30	Ω	
			Full						35
ON-state resistance	r_{on}	$V_{NO} \text{ or } V_{NC} = 0$, $I_{COM} = 8 \text{ mA}$ Switch ON, See Figure 14	25°C	2.3 V		6.6	8.5	Ω	
			Full						12
			25°C						8.9
			Full						25
ON-state resistance match between channels	Δr_{on}	$V_{NO} \text{ or } V_{NC} = 1.6 \text{ V}$, $I_{COM} = -8 \text{ mA}$, Switch ON, See Figure 14	25°C	2.3 V		0.05	0.3	Ω	
			Full						0.5
ON-state resistance flatness	$r_{on(Flat)}$	$0 \leq (V_{NO} \text{ or } V_{NC}) \leq V_+$, $I_{COM} = -8 \text{ mA}$, Switch ON, See Figure 14	25°C	2.3 V		5	15	Ω	
			Full						20
NC, NO OFF leakage current	$I_{NC(OFF)}, I_{NO(OFF)}$	$V_{NC} \text{ or } V_{NO} = 0 \text{ to } V_+$, $V_{COM} = V_+ \text{ to } 0$, Switch OFF, See Figure 15	25°C	2.7 V		0.1	10	nA	
			Full						100
NC, NO ON leakage current	$I_{NC(ON)}, I_{NO(ON)}$	$V_{NC} \text{ or } V_{NO} = 0 \text{ to } V_+$, $V_{COM} = \text{Open}$, Switch ON, See Figure 16	25°C	2.7 V		0.1	10	nA	
			Full						10
COM ON leakage current	$I_{COM(ON)}$	$V_{NC} \text{ or } V_{NO} = \text{Open}$, $V_{COM} = 0 \text{ to } V_+$, Switch ON, See Figure 16	25°C	2.7 V		0.1	10	nA	
			Full						100
Digital Control Input (IN)									
Input logic high	V_{IH}		Full		$V_+ \times 0.75$		5.5	V	
Input logic low	V_{IL}		Full		0		$V_+ \times 0.25$	V	
Input leakage current	I_{IH}, I_{IL}	$V_I = 5.5 \text{ V or } 0$	25°C	2.7 V		5	10	nA	
			Full						20

TS5A623157
DUAL 10-Ω SPDT ANALOG SWITCH
WITH UNDERSHOOT/OVERSHOOT VOLTAGE PROTECTION

SCDS253–SEPTEMBER 2007

Electrical Characteristics for 2.5-V Supply (continued)

$V_+ = 2.3 \text{ V to } 2.7 \text{ V}$, $T_A = -40^\circ\text{C to } 85^\circ\text{C}$ (unless otherwise noted)

PARAMETER	SYMBOL	TEST CONDITIONS	T_A	V_+	MIN	TYP	MAX	UNIT
Dynamic								
Turn-on time	t_{ON}	$V_{COM} = V_+$ or GND, $R_L = 500 \Omega$, $C_L = 50 \text{ pF}$, See Figure 17	25°C	2.5 V	2	6.2	9.6	ns
			Full	2.3 V to 2.7 V	2		12	
Turn-off time	t_{OFF}	$V_{COM} = V_+$ or GND, $R_L = 500 \Omega$, $C_L = 50 \text{ pF}$, See Figure 17	25°C	2.5 V	1.5	4.5	7.0	ns
			Full	2.3 V to 2.7 V	1.5		7.5	
Output voltage during undershoot	V_{OUTU}	See Figure 24			$V_{OH} - 0.3$			V
Output voltage during overshoot	V_{OUTO}	See Figure 24			$V_{OL} + 0.3$			2 V
Break-before-make time	t_{BBM}	$V_{NC} = V_{NO} = V_+/2$, $R_L = 50 \Omega$, $C_L = 50 \text{ pF}$, See Figure 18	25°C	2.5 V	0.5	10	25	ns
			Full	2.3 V to 2.7 V	0.5		28.5	
Charge injection	Q_C	$V_{GEN} = 0$, $R_{GEN} = 0$, $C_L = 0.1 \text{ nF}$, See Figure 22	25°C	2.5 V	58			pC
NC, NO OFF capacitance	$C_{NC(OFF)}$, $C_{NO(OFF)}$	V_{NC} or $V_{NO} = V_+$ or GND, Switch OFF, See Figure 16	25°C	2.5 V	5			pF
NC, NO ON capacitance	$C_{NC(ON)}$, $C_{NO(ON)}$	V_{NC} or $V_{NO} = V_+$ or GND, Switch ON, See Figure 16	25°C	2.5 V	14.5			pF
COM ON capacitance	$C_{COM(ON)}$	$V_{COM} = V_+$ or GND, Switch ON, See Figure 16	25°C	2.5 V	14.5			pF
Digital input capacitance	C_I	$V_I = V_+$ or GND, See Figure 16	25°C	2.5 V	3.5			pF
Bandwidth	BW	$R_L = 50 \Omega$, Switch ON, See Figure 19	25°C	2.5 V	367			MHz
OFF isolation	O_{ISO}	$R_L = 50 \Omega$, $f = 10 \text{ MHz}$, Switch OFF, See Figure 20	25°C	2.5 V	-60			dB
Crosstalk	X_{TALK}	$R_L = 50 \Omega$, $f = 10 \text{ MHz}$, Switch ON, See Figure 21	25°C	2.5 V	-60			dB
Total harmonic distortion	THD	$R_L = 600 \Omega$, $C_L = 50 \text{ pF}$, $f = 20 \text{ Hz to } 20 \text{ kHz}$, See Figure 23	25°C	2.5 V	0.15			%
Supply								
Positive supply current	I_+	$V_I = V_+$ or GND, Switch ON or OFF	25°C	2.7 V	50			nA
			Full		100 550			

PRODUCT PREVIEW

Electrical Characteristics for 1.8-V Supply

$V_+ = 1.65\text{ V to }1.95\text{ V}$, $T_A = -40^\circ\text{C to }85^\circ\text{C}$ (unless otherwise noted)

PARAMETER	SYMBOL	TEST CONDITIONS	T_A	V_+	MIN	TYP	MAX	UNIT	
Analog Switch									
Analog signal range	V_{COM}, V_{NO}, V_{NC}				0		V_+	V	
Voltage undershoot	V_{IKU}	$0 \geq (I_{NC}, I_{NO}, \text{ or } I_{COM}) \geq -50\text{ mA}$		1.95 V				V	
Peak ON-state resistance	r_{peak}	$0 \leq (V_{NO} \text{ or } V_{NC}) \leq V_+$, $I_{COM} = -4\text{ mA}$, Switch ON, See Figure 14	25°C	1.65 V		41.1	60	Ω	
			Full				120		
ON-state resistance	r_{on}	$V_{NO} \text{ or } V_{NC} = 0$, $I_{COM} = 4\text{ mA}$, Switch ON, See Figure 14	25°C	1.65 V		9.2	15	Ω	
			Full				15		
			25°C				1.8		40
			Full				45		
ON-state resistance match between channels	Δr_{on}	$V_{NO} \text{ or } V_{NC} = 1.15\text{ V}$, $I_{COM} = -4\text{ mA}$, Switch ON, See Figure 14	25°C	1.65 V		0.1	0.6	Ω	
			Full				0.8		
ON-state resistance flatness	$r_{on(Flat)}$	$0 \leq (V_{NO} \text{ or } V_{NC}) \leq V_+$, $I_{COM} = -4\text{ mA}$, Switch ON, See Figure 14	25°C	1.65 V		26.5	80	Ω	
			Full				100		
NC, NO OFF leakage current	$I_{NC(OFF)}, I_{NO(OFF)}$	$V_{NC} \text{ or } V_{NO} = 0 \text{ to } V_+$, $V_{COM} = V_+ \text{ to } 0$, Switch OFF, See Figure 15	25°C	1.95 V		0.05	10	nA	
			Full				100		
NC, NO ON leakage current	$I_{NC(ON)}, I_{NO(ON)}$	$V_{NC} \text{ or } V_{NO} = 0 \text{ to } V_+$, $V_{COM} = \text{Open}$, Switch ON, See Figure 16	25°C	1.95 V		0.1	10	μA	
			Full				100		
COM ON leakage current	$I_{COM(ON)}$	$V_{NC} \text{ or } V_{NO} = \text{Open}$, $V_{COM} = 0 \text{ to } V_+$, Switch ON, See Figure 16	25°C	1.95 V		0.1	10	nA	
			Full				100		
Digital Control Input (IN)									
Input logic high	V_{IH}		Full		$V_+ \times 0.75$		5.5	V	
Input logic low	V_{IL}		Full		0		$V_+ \times 0.25$	V	
Input leakage current	I_{IH}, I_{IL}	$V_I = 5.5\text{ V or }0$	25°C	1.95 V		0.05	1	nA	
			Full				20		

TS5A623157
DUAL 10-Ω SPDT ANALOG SWITCH
WITH UNDERSHOOT/OVERSHOOT VOLTAGE PROTECTION

SCDS253–SEPTEMBER 2007

Electrical Characteristics for 1.8-V Supply (continued)

$V_+ = 1.65\text{ V to }1.95\text{ V}$, $T_A = -40^\circ\text{C to }85^\circ\text{C}$ (unless otherwise noted)

PARAMETER	SYMBOL	TEST CONDITIONS	T_A	V_+	MIN	TYP	MAX	UNIT
Dynamic								
Turn-on time	t_{ON}	$V_{COM} = V_+$ or GND, $R_L = 500\ \Omega$, $C_L = 50\text{ pF}$, See Figure 17	25°C	1.8 V	9.6	23	ns	
			Full	1.65 V to 1.95 V		24		
Turn-off time	t_{OFF}	$V_{COM} = V_+$ or GND, $R_L = 500\ \Omega$, $C_L = 50\text{ pF}$, See Figure 17	25°C	1.8 V	6.3	10	ns	
			Full	1.65 V to 1.95 V		12		
Output voltage during undershoot	V_{OUTU}	See Figure 24			$V_{OH} - 0.3$		V	
Output voltage during overshoot	V_{OUTO}	See Figure 24			$V_{OL} + 0.3$		V	
Break-before-make time	t_{BBM}	$V_{NC} = V_{NO} = V_+/2$, $R_L = 50\ \Omega$, $C_L = 50\text{ pF}$, See Figure 18	25°C	1.8 V	0.5	18	50	ns
			Full	1.65 V to 1.95 V	0.5	55		
Charge injection	Q_C	$V_{GEN} = 0$, $R_{GEN} = 0$, $C_L = 0.1\text{ nF}$, See Figure 22	25°C	1.8 V	40		pC	
NC, NO OFF capacitance	$C_{NC(OFF)}$, $C_{NO(OFF)}$	V_{NC} or $V_{NO} = V_+$ or GND, Switch OFF, See Figure 16	25°C	1.8 V	5.0		pF	
NC, NO ON capacitance	$C_{NC(ON)}$, $C_{NO(ON)}$	V_{NC} or $V_{NO} = V_+$ or GND, Switch ON, See Figure 16	25°C	1.8 V	14.5		pF	
COM ON capacitance	$C_{COM(ON)}$	$V_{COM} = V_+$ or GND, Switch ON, See Figure 16	25°C	1.8 V	14.5		pF	
Digital input capacitance	C_I	$V_I = V_+$ or GND, See Figure 16	25°C	1.8 V	3.5		pF	
Bandwidth	BW	$R_L = 50\ \Omega$, Switch ON, See Figure 19	25°C	1.8 V	369		MHz	
OFF isolation	O_{ISO}	$R_L = 50\ \Omega$, $f = 10\text{ MHz}$, Switch OFF, See Figure 20	25°C	1.8 V	-60		dB	
Crosstalk	X_{TALK}	$R_L = 50\ \Omega$, $f = 10\text{ MHz}$, Switch ON, See Figure 21	25°C	1.8 V	-60		dB	
Total harmonic distortion	THD	$R_L = 600\ \Omega$, $C_L = 50\text{ pF}$, $f = 20\text{ Hz to }20\text{ kHz}$, See Figure 23	25°C	1.8 V	0.4		%	
Supply								
Positive supply current	I_+	$V_I = V_+$ or GND, Switch ON or OFF	25°C	1.95 V	0.1	50	nA	
			Full		400			

PRODUCT PREVIEW

PIN DESCRIPTION

PIN NO.	NAME	DESCRIPTION
1	IN1	Digital control to connect COM to NO or NC
2	NO1	Normally open
3	GND	Digital ground
4	NO2	Normally open
5	IN2	Digital control to connect COM to NO or NC
6	COM2	Common
7	NC2	Normally closed
8	V+	Power supply
9	NC1	Normally closed
10	COM1	Common

PARAMETER DESCRIPTION

SYMBOL	DESCRIPTION
V_{COM}	Voltage at COM
V_{NC}	Voltage at NC
V_{NO}	Voltage at NO
r_{on}	Resistance between COM and NC or COM and NO ports when the channel is ON
Δr_{on}	Difference of r_{on} between channels
$r_{on(flat)}$	Difference between the maximum and minimum value of r_{on} in a channel over the specified range of conditions
$I_{NC(OFF)}$	Leakage current measured at the NC port, with the corresponding channel (NC to COM) in the OFF state under worst-case input and output conditions
$I_{NO(OFF)}$	Leakage current measured at the NO port, with the corresponding channel (NO to COM) in the OFF state under worst-case input and output conditions
$I_{NC(ON)}$	Leakage current measured at the NC port, with the corresponding channel (NC to COM) in the ON state and the output (COM) being open
$I_{NO(ON)}$	Leakage current measured at the NO port, with the corresponding channel (NO to COM) in the ON state and the output (COM) being open
$I_{COM(ON)}$	Leakage current measured at the COM port, with the corresponding channel (NO to COM or NC to COM) in the ON state and the output (NC or NO) being open
V_{IH}	Minimum input voltage for logic high for the control input (IN)
V_{IL}	Minimum input voltage for logic low for the control input (IN)
V_{IN}	Voltage at control input (IN)
I_{IH}, I_{IL}	Leakage current measured at control input (IN)
t_{ON}	Turn-on time for the switch. This parameter is measured under the specified range of conditions and by the propagation delay between the digital control (IN) signal and analog outputs (COM/NC/NO) signal when the switch is turning ON.
t_{OFF}	Turn-off time for the switch. This parameter is measured under the specified range of conditions and by the propagation delay between the digital control (IN) signal and analog outputs (COM/NC/NO) signal when the switch is turning OFF.
t_{BBM}	Break-before-make time. This parameter is measured under the specified range of conditions and by the propagation delay between the output of two adjacent analog channels (NC and NO) when the control signal changes state.
Q_C	Charge injection is a measurement of unwanted signal coupling from the control (IN) input to the analog (NC, NO, or COM) output. This is measured in coulombs (=) and measured by the total charge induced due to switching of the control input. Charge injection, $Q_C = C_L \times \Delta V_O$, C_L is the load capacitance and ΔV_O is the change in analog output voltage.
$C_{NC(OFF)}$	Capacitance at the NC port when the corresponding channel (NC to COM) is OFF
$C_{NO(OFF)}$	Capacitance at the NO port when the corresponding channel (NC to COM) is OFF
$C_{NC(ON)}$	Capacitance at the NC port when the corresponding channel (NC to COM) is ON
$C_{NO(ON)}$	Capacitance at the NO port when the corresponding channel (NC to COM) is ON
$C_{COM(ON)}$	Capacitance at the COM port when the corresponding channel (COM to NC or COM to NO) is ON
C_1	Capacitance of control input (IN)
O_{ISO}	OFF isolation of the switch is a measurement of OFF-state switch impedance. This is measured in dB in a specific frequency, with the corresponding channel (NC to COM or NO to COM) in the OFF state.

TS5A623157
DUAL 10-Ω SPDT ANALOG SWITCH
WITH UNDERSHOOT/OVERSHOOT VOLTAGE PROTECTION

SCDS253–SEPTEMBER 2007

PARAMETER DESCRIPTION (continued)

SYMBOL	DESCRIPTION
X_{TALK}	Crosstalk is a measurement of unwanted signal coupling from an ON channel to an OFF channel (NC to NO or NO to NC). This is measured at a specific frequency and in dB.
BW	Bandwidth of the switch. This is the frequency where the gain of an ON channel is –3 dB below the dc gain.
THD	Total harmonic distortion is defined as the ratio of the root mean square (RMS) value of the second, third, and higher harmonics to the magnitude of fundamental harmonic.
I+	Static power-supply current with the control (IN) pin at V+ or GND
V_{OUTU}	Output voltage during an undershoot event. This is measured by turning off a specific channel and applying an undershoot voltage at the input of the switch.
V_{OUTO}	Output voltage during an overshoot event. This is measured by turning off a specific channel and applying an overshoot voltage at the input of the switch.

TYPICAL CHARACTERISTICS

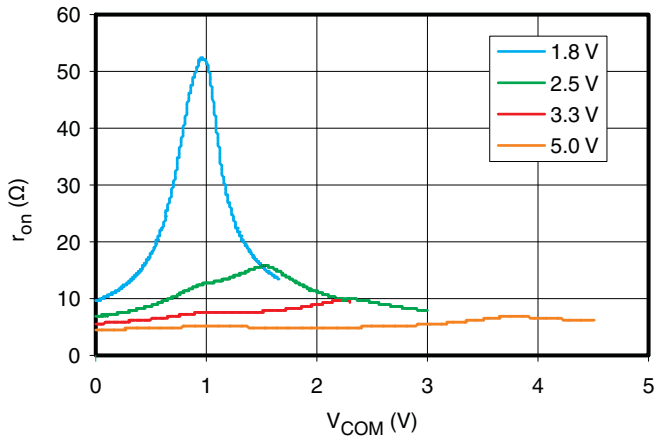

Figure 1. r_{ON} vs V_{COM}

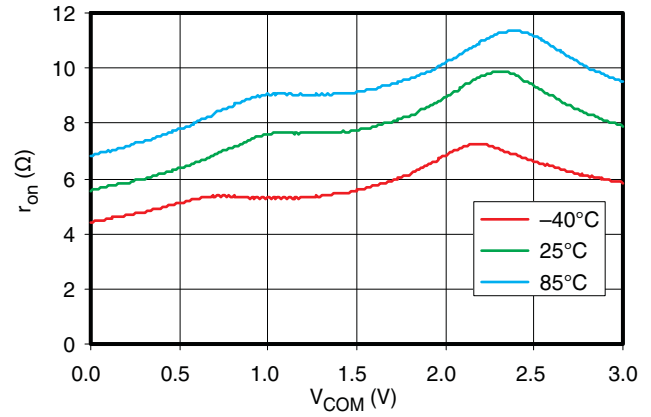

Figure 2. r_{ON} vs V_{COM} ($V_+ = 3.3$ V)

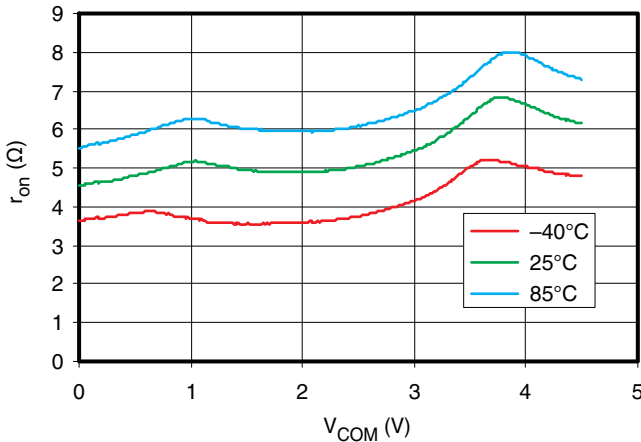

Figure 3. r_{ON} vs V_{COM} ($V_+ = 5$ V)

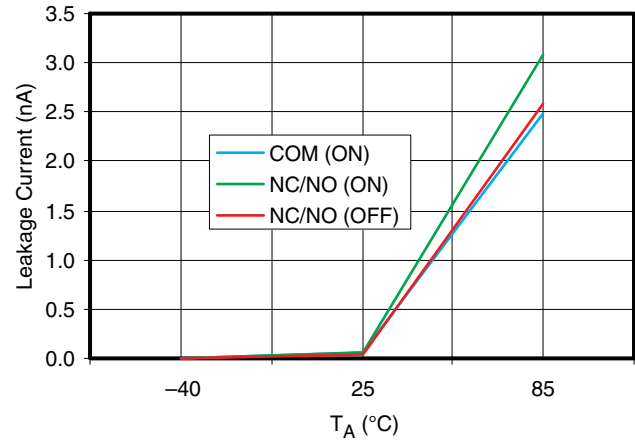

Figure 4. Leakage Current vs Temperature

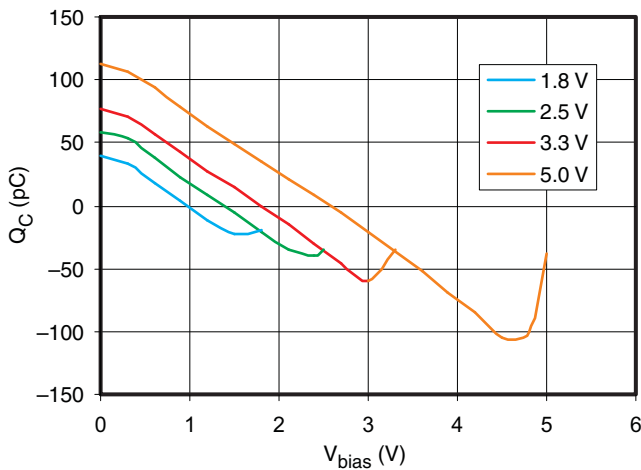

Figure 5. Charge Injection vs V_{COM}

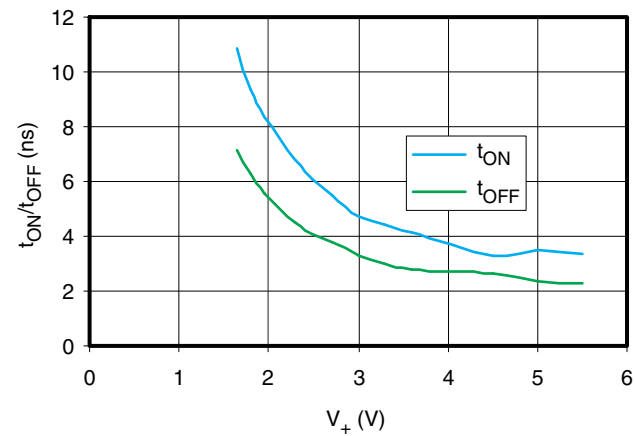

Figure 6. t_{ON} and t_{OFF} vs Supply Voltage

PRODUCT PREVIEW

TYPICAL CHARACTERISTICS (continued)

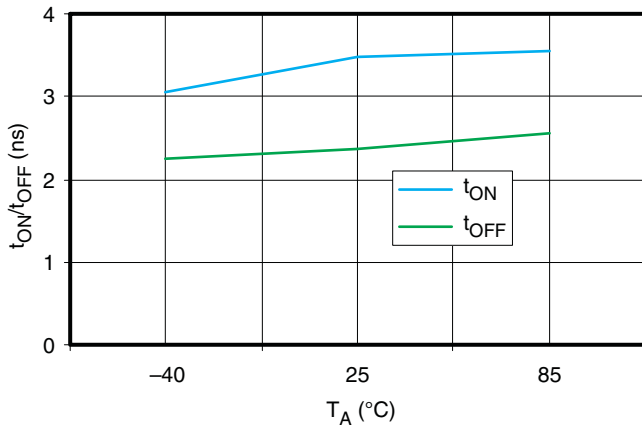

Figure 7. t_{ON} and t_{OFF} vs Temperature

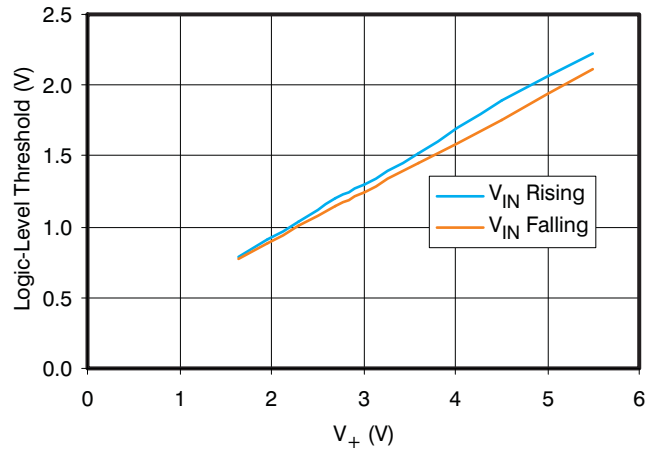

Figure 8. Logic-Level Threshold

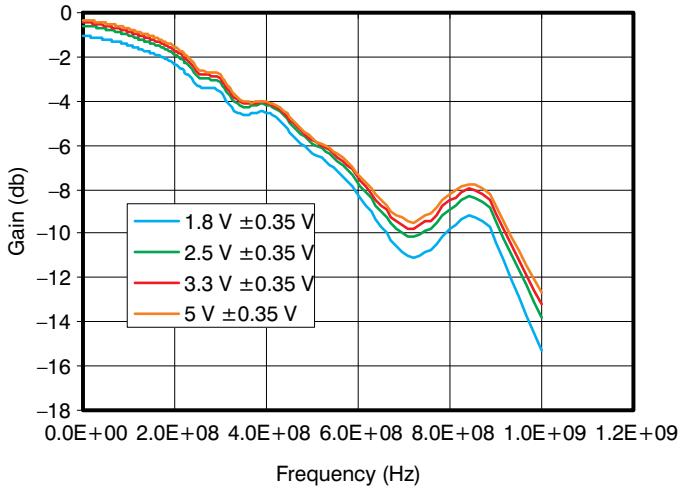

Figure 9. Bandwidth (BW)

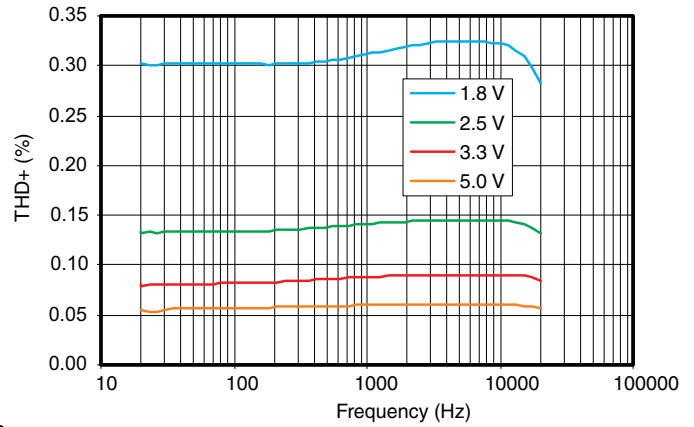

Figure 10. Total Harmonic Distortion (THD) vs Frequency

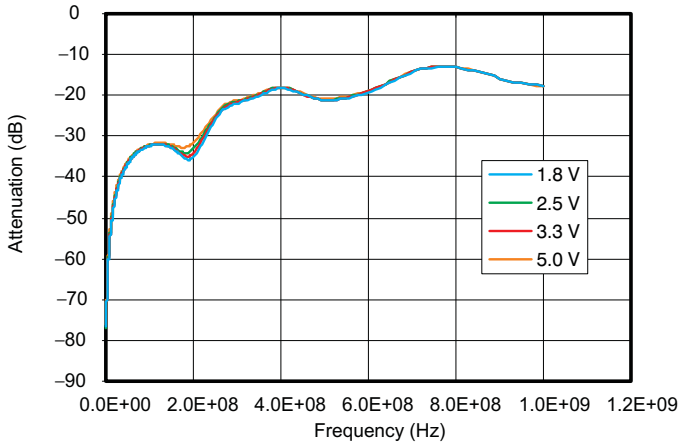

Figure 11. Off Isolation

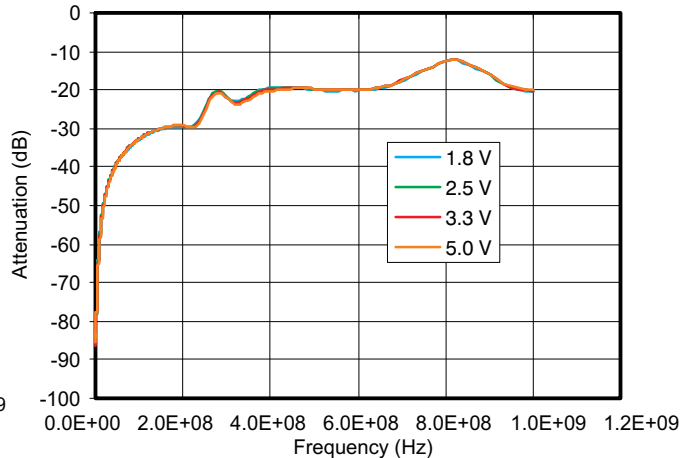

Figure 12. Crosstalk

PRODUCT PREVIEW

TYPICAL CHARACTERISTICS (continued)

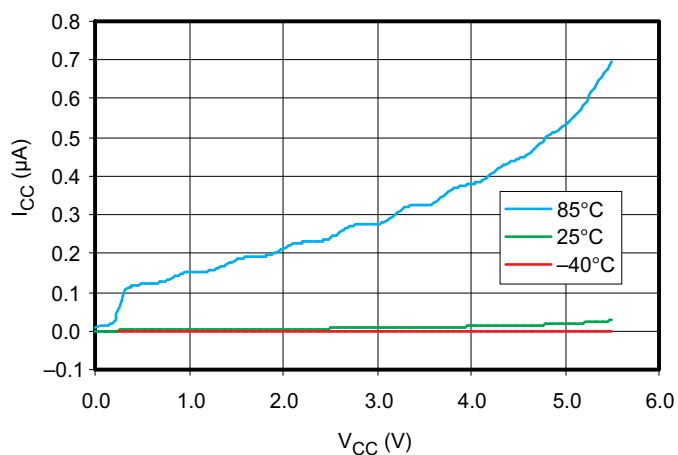

Figure 13. Supply Current vs Supply Voltage

PARAMETER MEASUREMENT INFORMATION

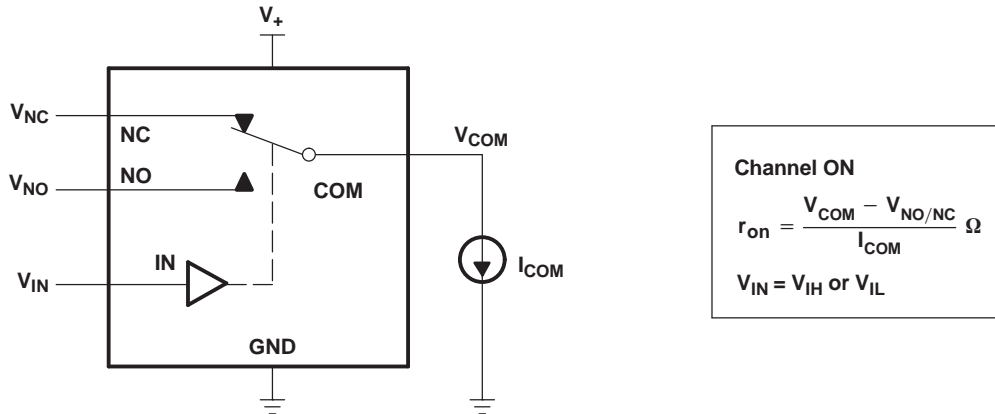

Figure 14. ON-State Resistance (r_{on})

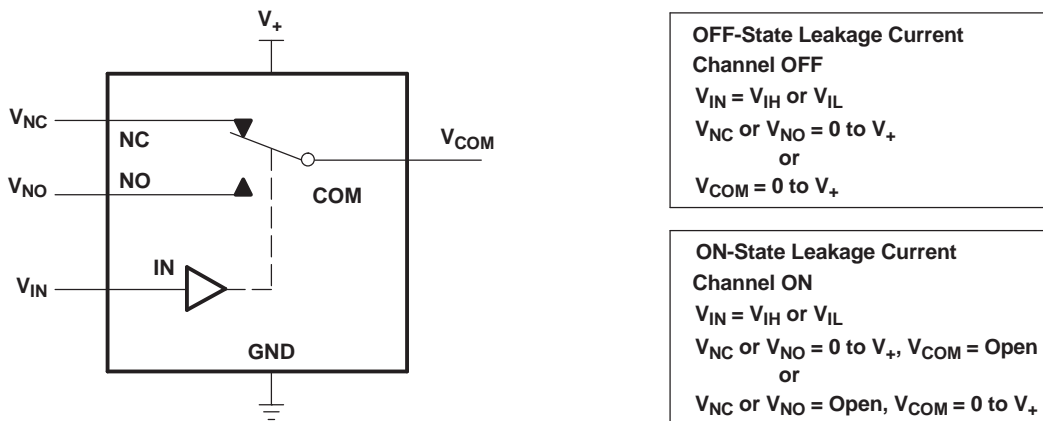

Figure 15. ON- and OFF-State Leakage Current ($I_{COM(ON)}$, $I_{NC(OFF)}$, $I_{NO(OFF)}$, $I_{NC(ON)}$, $I_{NO(ON)}$)

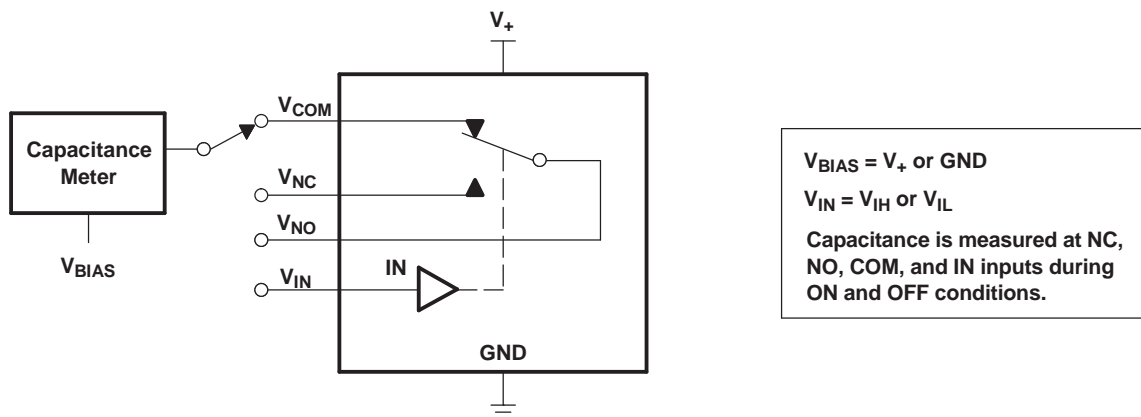
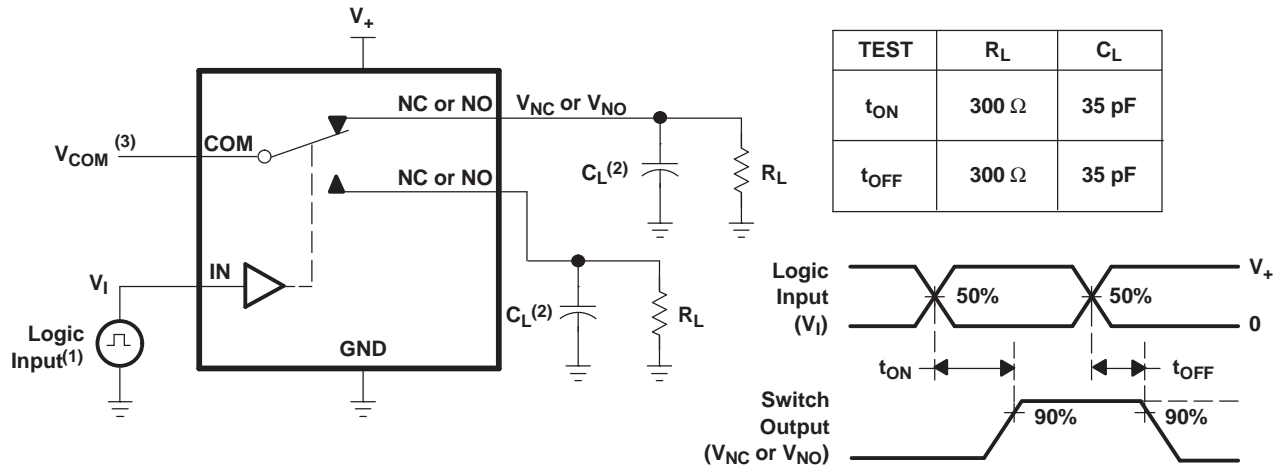

Figure 16. Capacitance (C_{IN} , $C_{COM(ON)}$, $C_{NC(OFF)}$, $C_{NO(OFF)}$, $C_{NC(ON)}$, $C_{NO(ON)}$)

PRODUCT PREVIEW

PARAMETER MEASUREMENT INFORMATION (continued)



- (1) All input pulses are supplied by generators having the following characteristics: PRR ≤ 10 MHz, Z_O = 50 Ω, t_r < 5 ns, t_f < 5 ns.
- (2) C_L includes probe and jig capacitance.
- (3) See Electrical Characteristic for V_{COM}.

Figure 17. Turn-On (t_{ON}) and Turn-Off (t_{OFF}) Time

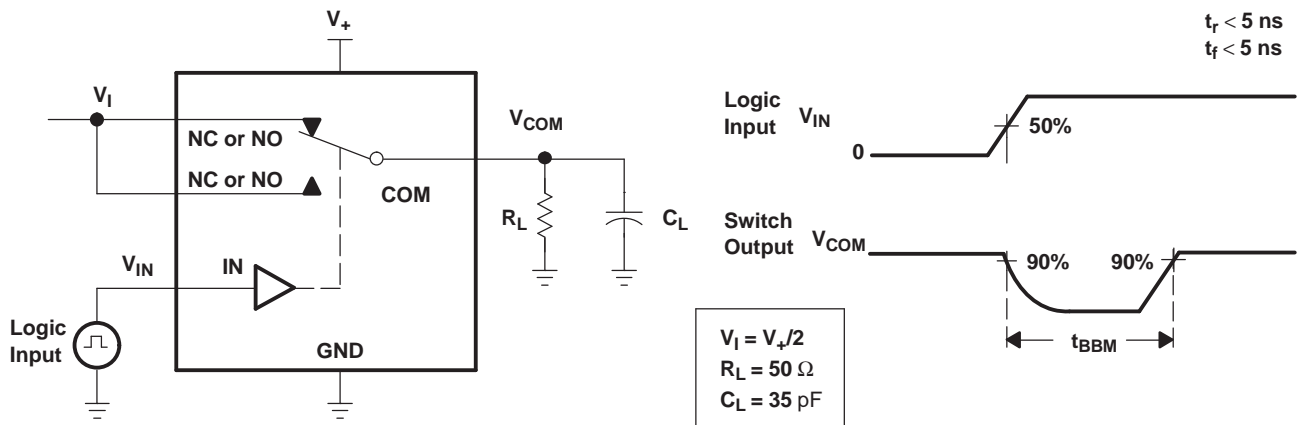

Figure 18. Break-Before-Make (t_{BBM}) Time

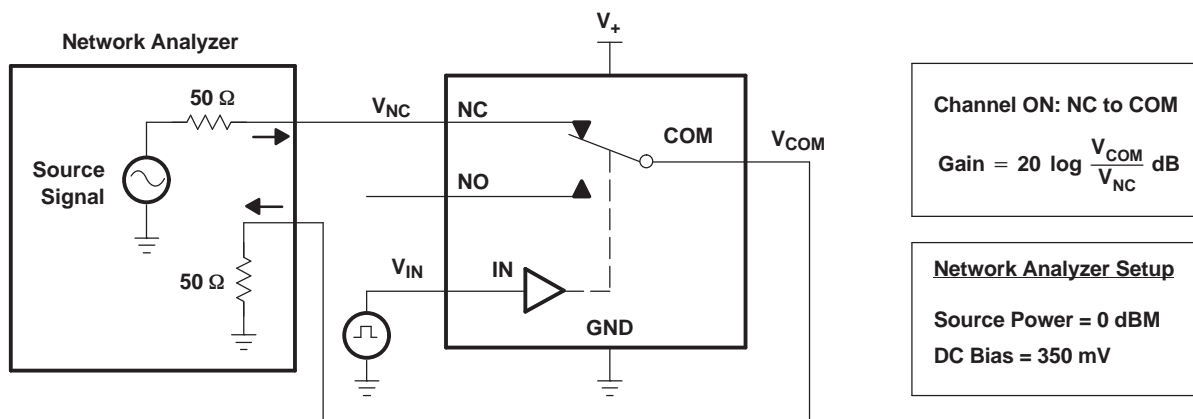

Figure 19. Frequency Response (BW)

PARAMETER MEASUREMENT INFORMATION (continued)

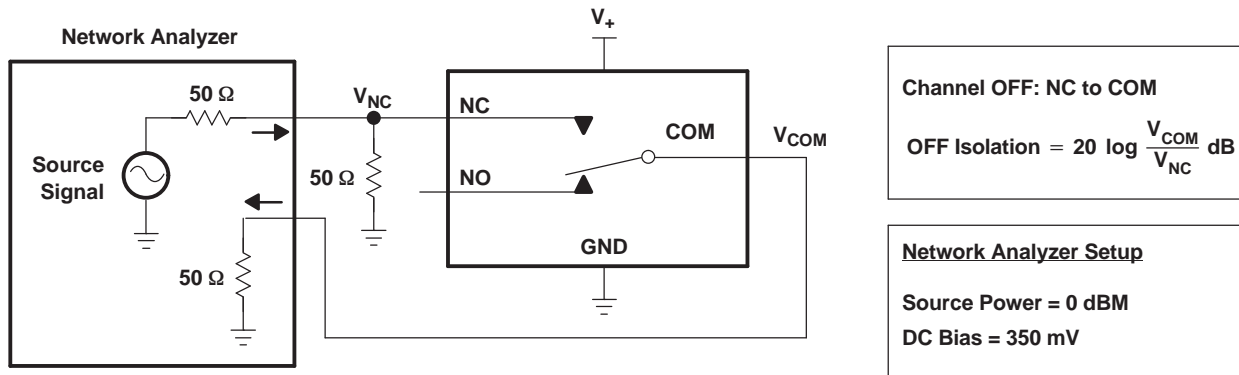

Figure 20. OFF Isolation (O_{ISO})

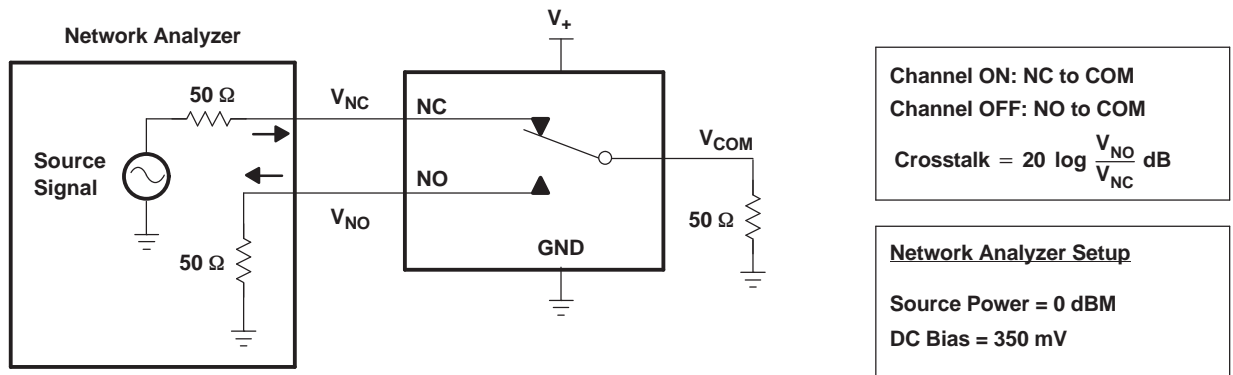

Figure 21. Crosstalk (X_{TALK})

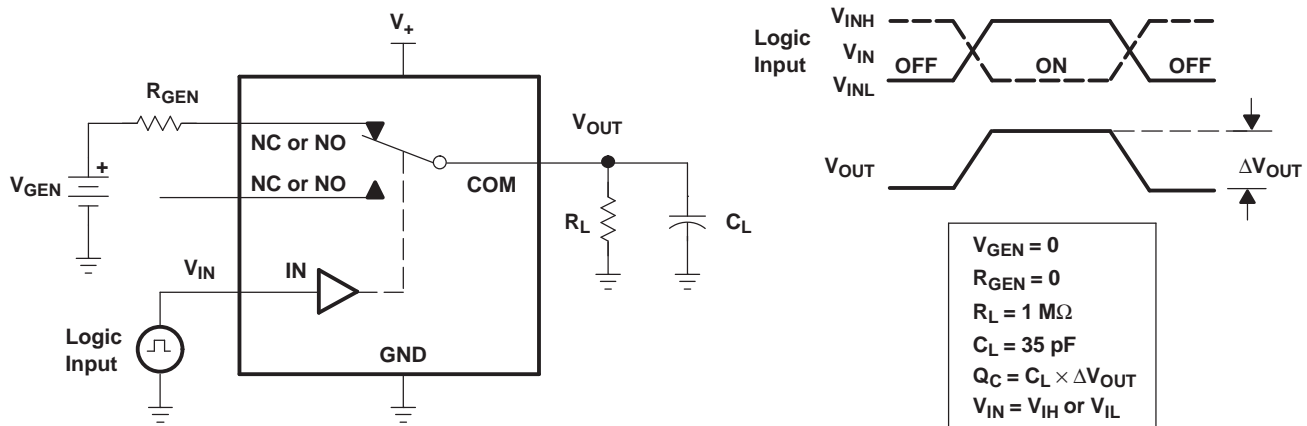

Figure 22. Charge Injection (Q_C)

PARAMETER MEASUREMENT INFORMATION (continued)

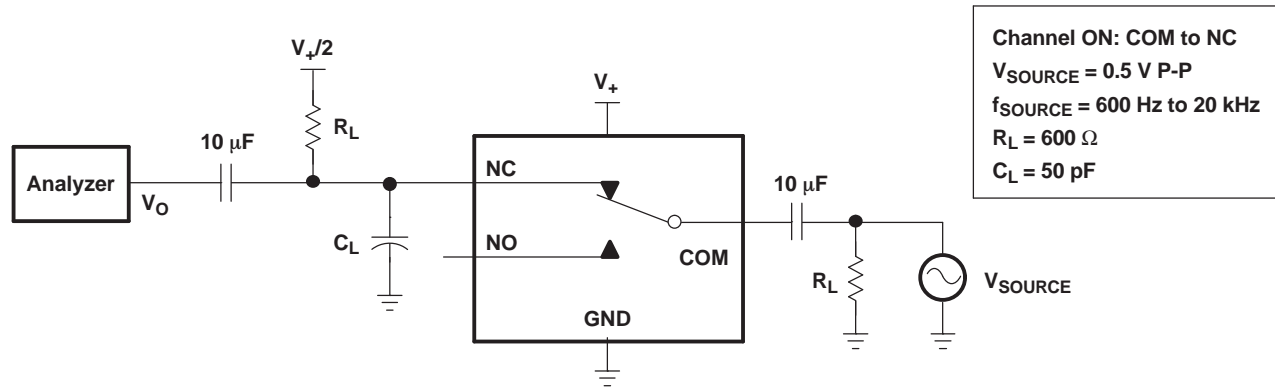
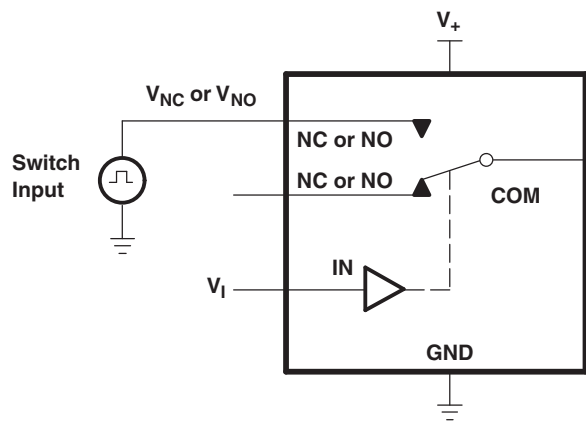

Figure 23. Total Harmonic Distortion (THD)



TEST	R_L	C_L	V_{TR}	V_I
V_{OUTU}	100 kΩ	10 pF	7 V	V_+ or GND Switch OFF
V_{OUTO}	100 kΩ	10 pF	GND	V_+ or GND Switch OFF

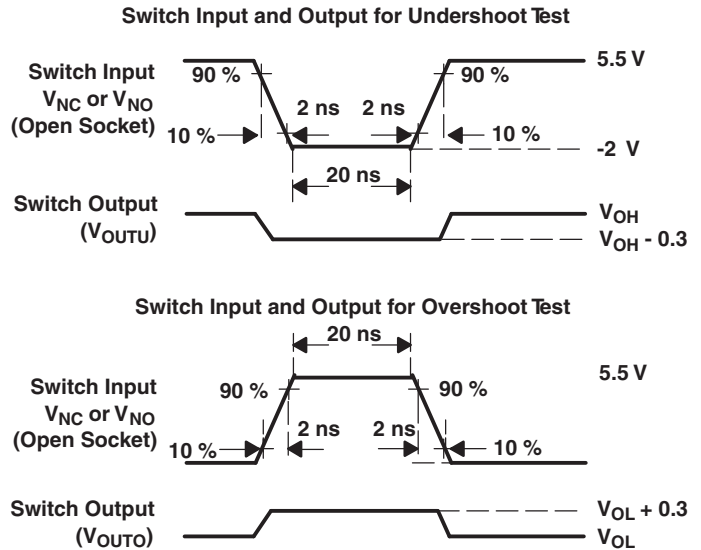

Figure 24. Undershoot and Overshoot Test

PRODUCT PREVIEW

PACKAGING INFORMATION

Orderable Device	Status (1)	Package Type	Package Drawing	Pins	Package Qty	Eco Plan (2)	Lead/Ball Finish	MSL Peak Temp (3)	Op Temp (°C)	Device Marking (4/5)	Samples
TS5A623157DGSR	ACTIVE	VSSOP	DGS	10	2500	Green (RoHS & no Sb/Br)	CU NIPDAU	Level-1-260C-UNLIM	-40 to 85	35R	Samples
TS5A623157DGSRG4	ACTIVE	VSSOP	DGS	10	2500	Green (RoHS & no Sb/Br)	CU NIPDAU	Level-1-260C-UNLIM	-40 to 85	35R	Samples

(1) The marketing status values are defined as follows:

ACTIVE: Product device recommended for new designs.

LIFEBUY: TI has announced that the device will be discontinued, and a lifetime-buy period is in effect.

NRND: Not recommended for new designs. Device is in production to support existing customers, but TI does not recommend using this part in a new design.

PREVIEW: Device has been announced but is not in production. Samples may or may not be available.

OBSELETE: TI has discontinued the production of the device.

(2) Eco Plan - The planned eco-friendly classification: Pb-Free (RoHS), Pb-Free (RoHS Exempt), or Green (RoHS & no Sb/Br) - please check <http://www.ti.com/productcontent> for the latest availability information and additional product content details.

TBD: The Pb-Free/Green conversion plan has not been defined.

Pb-Free (RoHS): TI's terms "Lead-Free" or "Pb-Free" mean semiconductor products that are compatible with the current RoHS requirements for all 6 substances, including the requirement that lead not exceed 0.1% by weight in homogeneous materials. Where designed to be soldered at high temperatures, TI Pb-Free products are suitable for use in specified lead-free processes.

Pb-Free (RoHS Exempt): This component has a RoHS exemption for either 1) lead-based flip-chip solder bumps used between the die and package, or 2) lead-based die adhesive used between the die and leadframe. The component is otherwise considered Pb-Free (RoHS compatible) as defined above.

Green (RoHS & no Sb/Br): TI defines "Green" to mean Pb-Free (RoHS compatible), and free of Bromine (Br) and Antimony (Sb) based flame retardants (Br or Sb do not exceed 0.1% by weight in homogeneous material)

(3) MSL, Peak Temp. -- The Moisture Sensitivity Level rating according to the JEDEC industry standard classifications, and peak solder temperature.

(4) There may be additional marking, which relates to the logo, the lot trace code information, or the environmental category on the device.

(5) Multiple Device Markings will be inside parentheses. Only one Device Marking contained in parentheses and separated by a "~" will appear on a device. If a line is indented then it is a continuation of the previous line and the two combined represent the entire Device Marking for that device.

Important Information and Disclaimer:The information provided on this page represents TI's knowledge and belief as of the date that it is provided. TI bases its knowledge and belief on information provided by third parties, and makes no representation or warranty as to the accuracy of such information. Efforts are underway to better integrate information from third parties. TI has taken and continues to take reasonable steps to provide representative and accurate information but may not have conducted destructive testing or chemical analysis on incoming materials and chemicals. TI and TI suppliers consider certain information to be proprietary, and thus CAS numbers and other limited information may not be available for release.

In no event shall TI's liability arising out of such information exceed the total purchase price of the TI part(s) at issue in this document sold by TI to Customer on an annual basis.

TAPE AND REEL INFORMATION



QUADRANT ASSIGNMENTS FOR PIN 1 ORIENTATION IN TAPE



*All dimensions are nominal

Device	Package Type	Package Drawing	Pins	SPQ	Reel Diameter (mm)	Reel Width W1 (mm)	A0 (mm)	B0 (mm)	K0 (mm)	P1 (mm)	W (mm)	Pin1 Quadrant
TS5A623157DGSR	VSSOP	DGS	10	2500	330.0	12.4	5.3	3.4	1.4	8.0	12.0	Q1

TAPE AND REEL BOX DIMENSIONS



*All dimensions are nominal

Device	Package Type	Package Drawing	Pins	SPQ	Length (mm)	Width (mm)	Height (mm)
TS5A623157DGSR	VSSOP	DGS	10	2500	358.0	335.0	35.0

DGS (S-PDSO-G10)

PLASTIC SMALL-OUTLINE PACKAGE

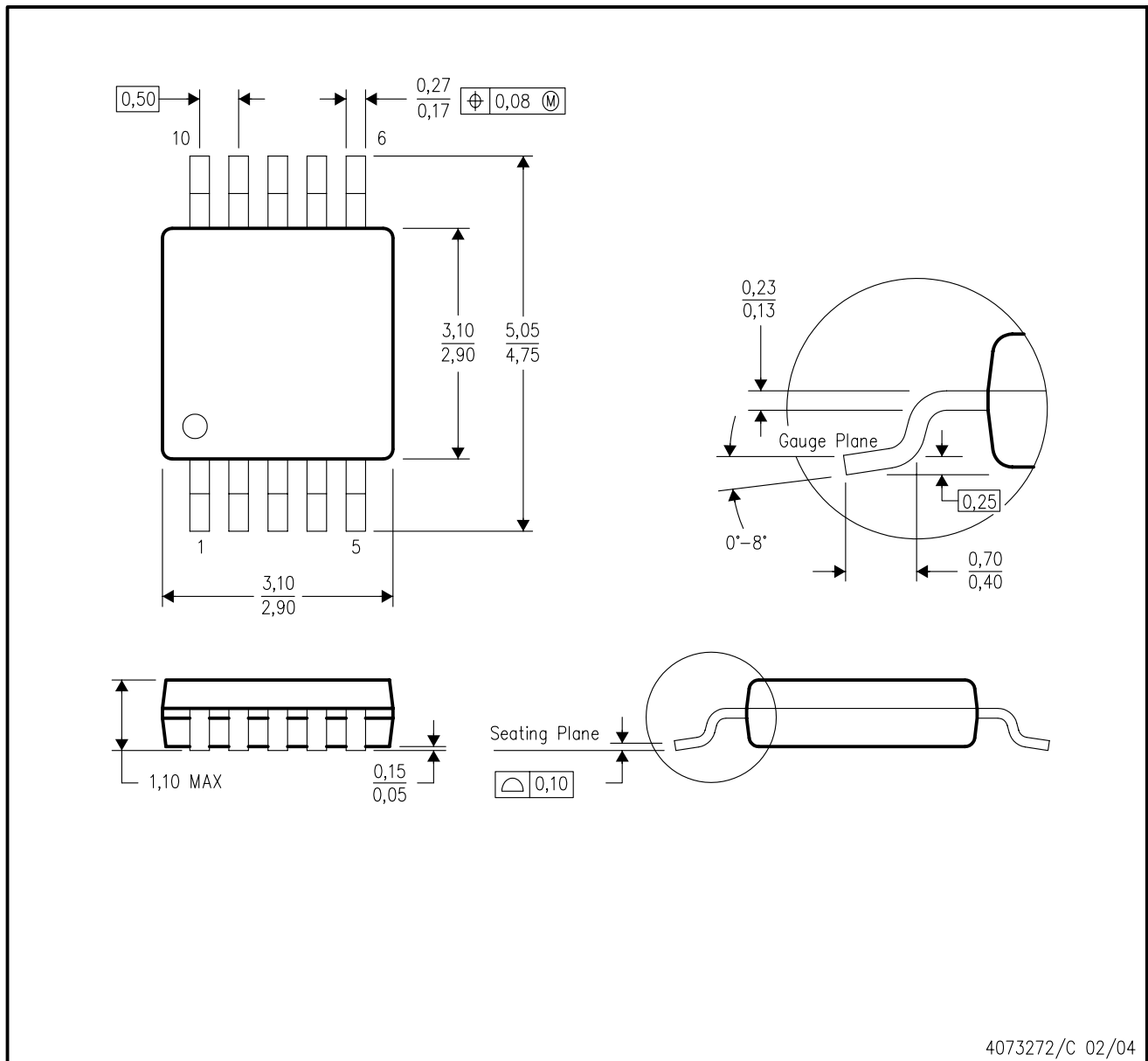

- NOTES:
- A. All linear dimensions are in millimeters.
 - B. This drawing is subject to change without notice.
 - C. Body dimensions do not include mold flash or protrusion.
 - D. Falls within JEDEC MO-187 variation BA.

IMPORTANT NOTICE

Texas Instruments Incorporated and its subsidiaries (TI) reserve the right to make corrections, enhancements, improvements and other changes to its semiconductor products and services per JESD46, latest issue, and to discontinue any product or service per JESD48, latest issue. Buyers should obtain the latest relevant information before placing orders and should verify that such information is current and complete. All semiconductor products (also referred to herein as "components") are sold subject to TI's terms and conditions of sale supplied at the time of order acknowledgment.

TI warrants performance of its components to the specifications applicable at the time of sale, in accordance with the warranty in TI's terms and conditions of sale of semiconductor products. Testing and other quality control techniques are used to the extent TI deems necessary to support this warranty. Except where mandated by applicable law, testing of all parameters of each component is not necessarily performed.

TI assumes no liability for applications assistance or the design of Buyers' products. Buyers are responsible for their products and applications using TI components. To minimize the risks associated with Buyers' products and applications, Buyers should provide adequate design and operating safeguards.

TI does not warrant or represent that any license, either express or implied, is granted under any patent right, copyright, mask work right, or other intellectual property right relating to any combination, machine, or process in which TI components or services are used. Information published by TI regarding third-party products or services does not constitute a license to use such products or services or a warranty or endorsement thereof. Use of such information may require a license from a third party under the patents or other intellectual property of the third party, or a license from TI under the patents or other intellectual property of TI.

Reproduction of significant portions of TI information in TI data books or data sheets is permissible only if reproduction is without alteration and is accompanied by all associated warranties, conditions, limitations, and notices. TI is not responsible or liable for such altered documentation. Information of third parties may be subject to additional restrictions.

Resale of TI components or services with statements different from or beyond the parameters stated by TI for that component or service voids all express and any implied warranties for the associated TI component or service and is an unfair and deceptive business practice. TI is not responsible or liable for any such statements.

Buyer acknowledges and agrees that it is solely responsible for compliance with all legal, regulatory and safety-related requirements concerning its products, and any use of TI components in its applications, notwithstanding any applications-related information or support that may be provided by TI. Buyer represents and agrees that it has all the necessary expertise to create and implement safeguards which anticipate dangerous consequences of failures, monitor failures and their consequences, lessen the likelihood of failures that might cause harm and take appropriate remedial actions. Buyer will fully indemnify TI and its representatives against any damages arising out of the use of any TI components in safety-critical applications.

In some cases, TI components may be promoted specifically to facilitate safety-related applications. With such components, TI's goal is to help enable customers to design and create their own end-product solutions that meet applicable functional safety standards and requirements. Nonetheless, such components are subject to these terms.

No TI components are authorized for use in FDA Class III (or similar life-critical medical equipment) unless authorized officers of the parties have executed a special agreement specifically governing such use.

Only those TI components which TI has specifically designated as military grade or "enhanced plastic" are designed and intended for use in military/aerospace applications or environments. Buyer acknowledges and agrees that any military or aerospace use of TI components which have **not** been so designated is solely at the Buyer's risk, and that Buyer is solely responsible for compliance with all legal and regulatory requirements in connection with such use.

TI has specifically designated certain components as meeting ISO/TS16949 requirements, mainly for automotive use. In any case of use of non-designated products, TI will not be responsible for any failure to meet ISO/TS16949.

Products

Audio	www.ti.com/audio
Amplifiers	amplifier.ti.com
Data Converters	dataconverter.ti.com
DLP® Products	www.dlp.com
DSP	dsp.ti.com
Clocks and Timers	www.ti.com/clocks
Interface	interface.ti.com
Logic	logic.ti.com
Power Mgmt	power.ti.com
Microcontrollers	microcontroller.ti.com
RFID	www.ti-rfid.com
OMAP Applications Processors	www.ti.com/omap
Wireless Connectivity	www.ti.com/wirelessconnectivity

Applications

Automotive and Transportation	www.ti.com/automotive
Communications and Telecom	www.ti.com/communications
Computers and Peripherals	www.ti.com/computers
Consumer Electronics	www.ti.com/consumer-apps
Energy and Lighting	www.ti.com/energy
Industrial	www.ti.com/industrial
Medical	www.ti.com/medical
Security	www.ti.com/security
Space, Avionics and Defense	www.ti.com/space-avionics-defense
Video and Imaging	www.ti.com/video

TI E2E Community

e2e.ti.com

AMEYA360

Components Supply Platform

Authorized Distribution Brand :



Website :

Welcome to visit www.ameya360.com

Contact Us :

➤ Address :

401 Building No.5, JiuGe Business Center, Lane 2301, Yishan Rd
Minhang District, Shanghai , China

➤ Sales :

Direct +86 (21) 6401-6692

Email amall@ameya360.com

QQ 800077892

Skype [ameyasales1](#) [ameyasales2](#)

➤ Customer Service :

Email service@ameya360.com

➤ Partnership :

Tel +86 (21) 64016692-8333

Email mkt@ameya360.com