

Very low drop 1A regulator

Feature summary

- Low dropout voltage (450mV typ. at 1A)
- Very low quiescent current
- Thermal shutdown
- Short circuit protection
- Reverse polarity protection

Description

The L4941 is a three terminal 5V positive regulators available in TO-220 and DPAK packages, making it useful in a wide range of industrial and consumer applications. Thanks to its very low input/output voltage drop, these devices are particularly suitable for battery powered equipments, reducing consumption and

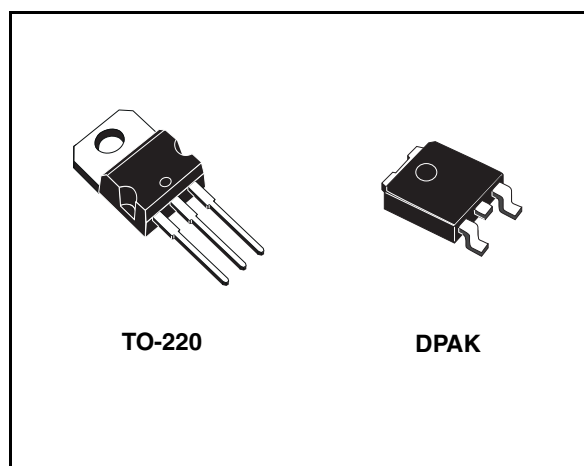

prolonging battery life. It employs internal current limiting, antisaturation circuit, thermal shut-down and safe area protection.

Order code

Part number	Package
L4941BV	TO-220
L4941BDT-TR	DPAK

Contents

1	Block diagram	3
2	Pin configuration	4
3	Maximum ratings	5
4	Test circuits	6
5	Electrical characteristics	7
6	Typical application	8
7	Schematic application	11
8	Package mechanical data	12
9	Revision history	16

1 Block diagram

Figure 1. Block diagram

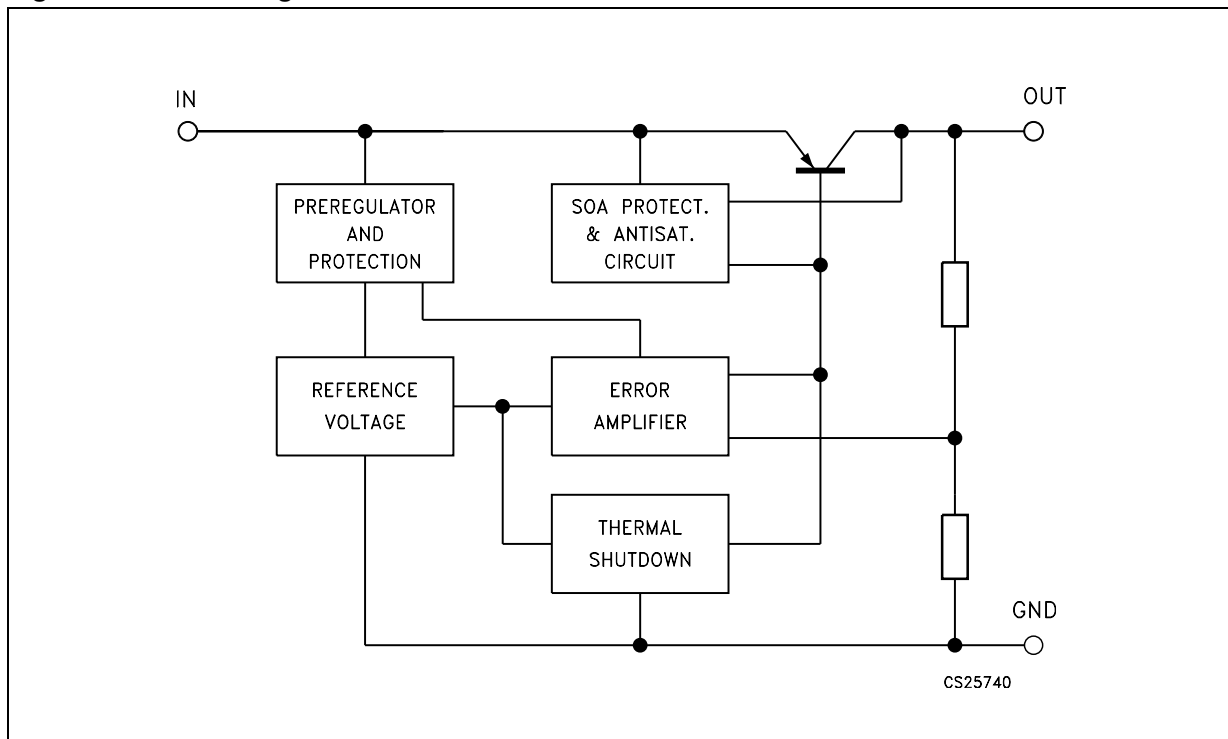

2 Pin configuration

Figure 2. Pin connections (top view)

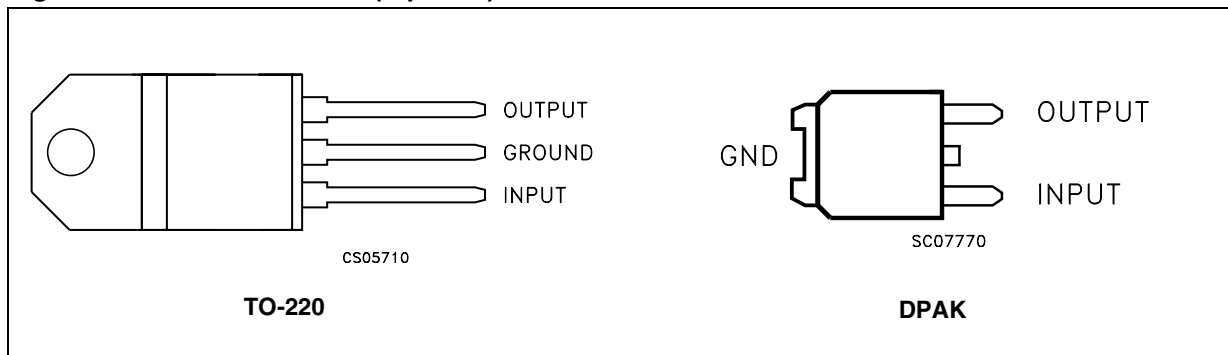

3 Maximum ratings

Table 1. Absolute maximum ratings

Symbol	Parameter	Value	Unit
V_I	Forward input voltage	30	V
V_{IR}	Reverse input voltage ($R_O=100\Omega$)	-15	V
I_O	Output current	Internally Limited	mA
P_D	Power dissipation	Internally Limited	mW
T_{stg}	Storage temperature range	-40 to +150	°C
T_{op}	Operating junction temperature range	-40 to +150	°C

Note: Absolute Maximum Ratings are those values beyond which damage to the device may occur. Functional operation under these condition is not implied

Table 2. Thermal Data

Symbol	Parameter	TO-220	DPAK	Unit
R_{thJC}	Thermal resistance junction-case	3	8	°C/W
R_{thJA}	Thermal resistance junction-ambient	50	100	°C/W

4 Test circuits

Figure 3. DC Parameters

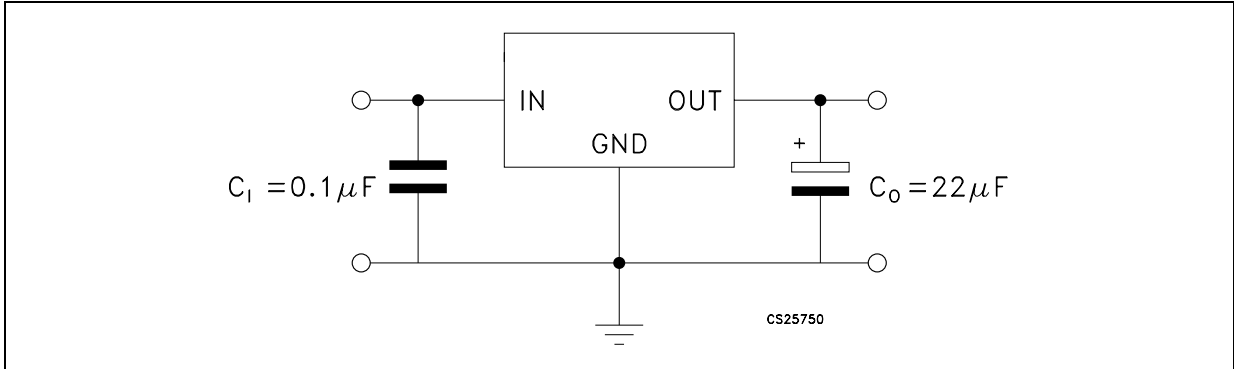

Figure 4. Load rejection

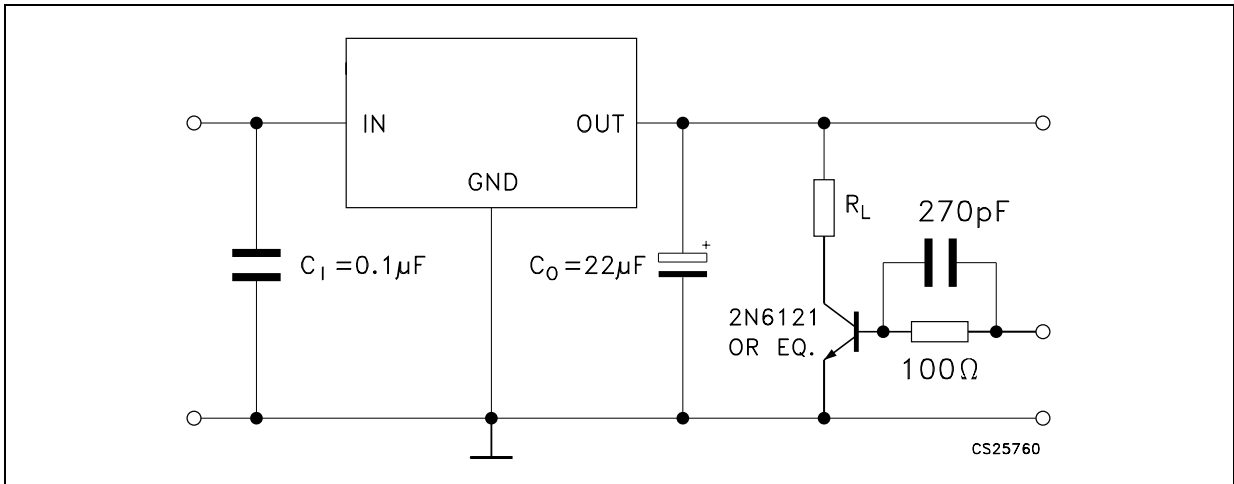
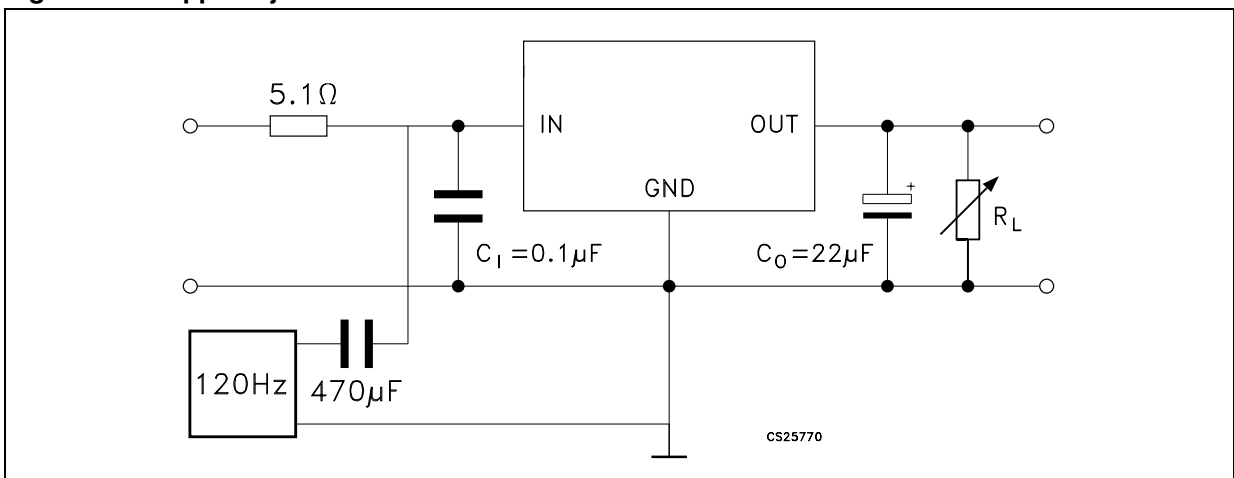

Figure 5. Ripple rejection



5 Electrical characteristics

Table 3. Electrical characteristics (refer to test circuit, $V_I=7V$, $C_1 = 0.1\mu F$, $C_O = 22\mu F$, $T_J = 25^\circ C$, unless otherwise specified.)

Symbol	Parameter	Test conditions	Min.	Typ.	Max.	Unit
V_O	Output voltage	$I_O = 5mA$ to 1A, $V_I = 6$ to 14V	4.8	5	5.2	V
V_I	Input voltage	$I_O = 5$ mA			16	V
ΔV_O	Line regulation	$V_I = 6$ to 16V, $I_O = 5$ mA		5	20	mV
ΔV_O	Load regulation	$I_O = 5mA$ to 1A		8	20	mV
		$I_O = 0.5A$ to 1A		5	15	mV
I_q	Quiescent current	$I_O = 5$ mA, $V_I = 6V$		4	8	mA
		$I_O = 1A$, $V_I = 6V$		20	40	mA
ΔI_q	Quiescent current change	$I_O = 5$ mA, $V_I = 6$ to 14V			3	mA
		$I_O = 1A$, $V_I = 6$ to 14V			-10	mA
V_d	Dropout voltage	$I_O = 0.5A$		250	450	mV
		$I_O = 1A$		450	700	mV
$\Delta V_O/\Delta T$	Output voltage drift			0.6		mV/°C
SVR	Supply voltage rejection	$f = 120Hz$, $I_O = 1A$	58	68		dB
I_{sc}	Short circuit current	$V_I = 14V$		1.6	2.0	A
		$V_I = 6V$		1.8	2.2	
Z_O	Output impedance	$f = 1KHz$, $I_O = 0.5A$		30		mΩ
e_N	Output noise voltage	$B = 100Hz$ to 100KHz		30		$\mu V/V_O$

6 Typical application

Figure 6. Dropout voltage vs output current

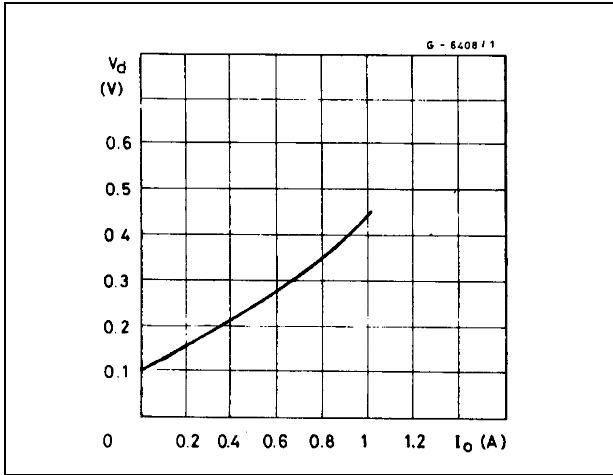

Figure 7. Dropout voltage vs temperature

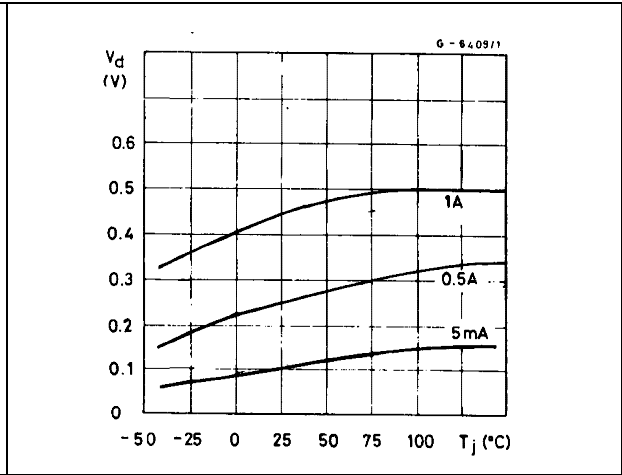

Figure 8. Output voltage vs temperature

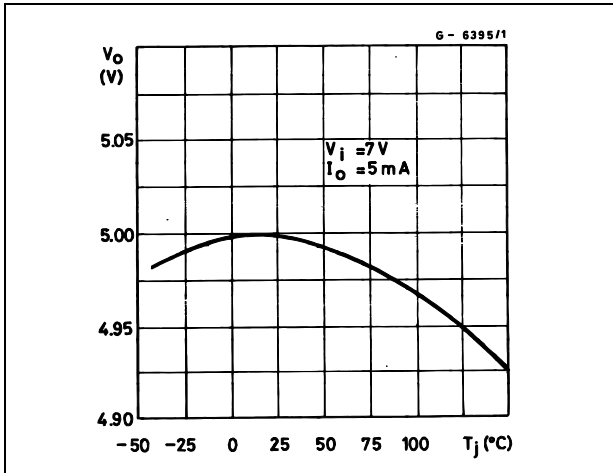

Figure 9. Quiescent current vs temperature

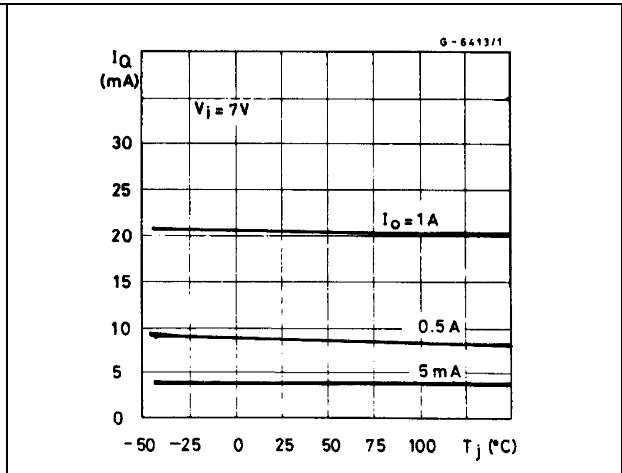

Figure 10. Quiescent current vs input voltage

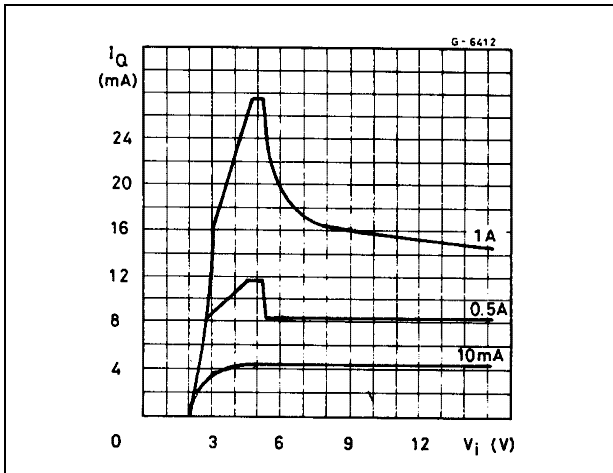

Figure 11. Quiescent current vs output current

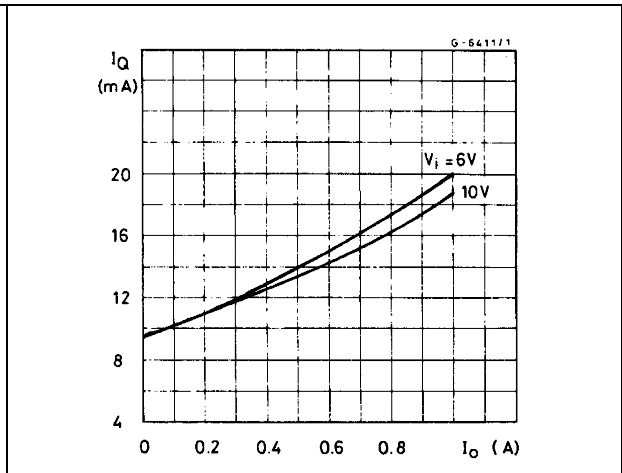

Figure 12. Short circuit current vs temperature Figure 13. Peak output current vs input/output differential voltage

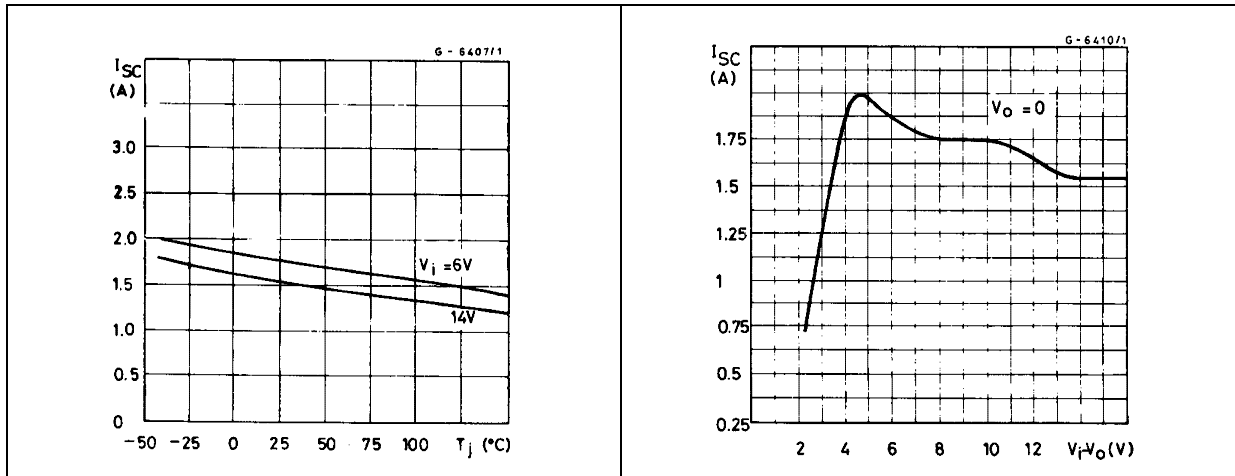

Figure 14. Low voltage behavior

Figure 15. Supply voltage rejection vs frequency

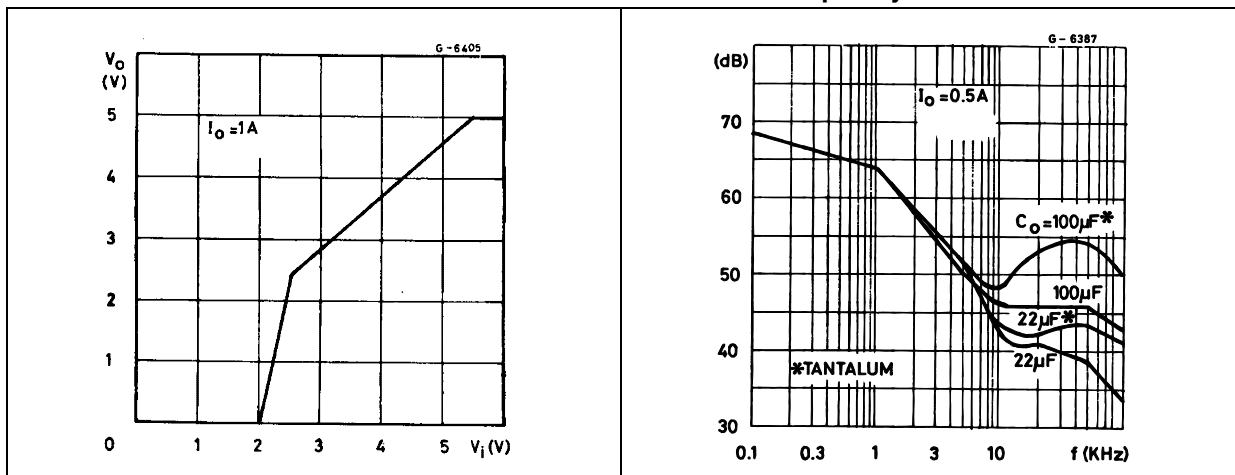

Figure 16. Supply voltage rejection vs output current

Figure 17. Load dump characteristics

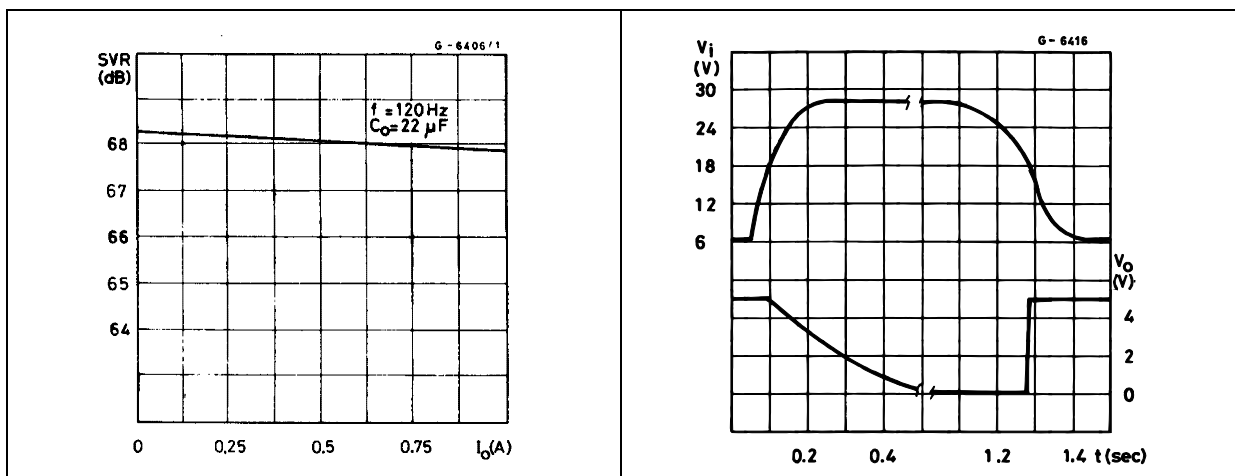

Figure 18. Line transient response

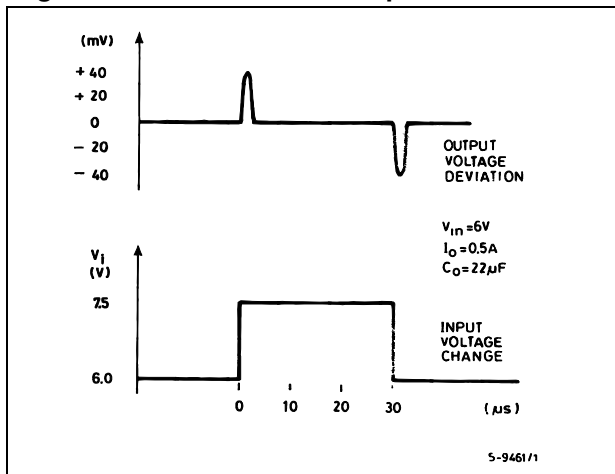

Figure 19. Total power dissipation

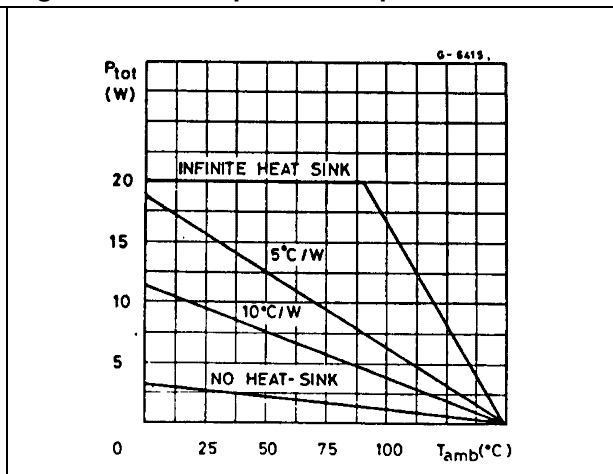
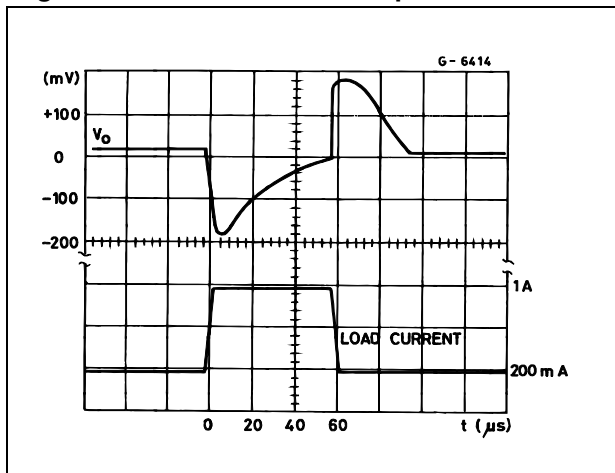

Figure 20. Load transient response



7 Schematic application

Figure 21. Distributed supply with On-card L4940 and L4941 low drop regulator

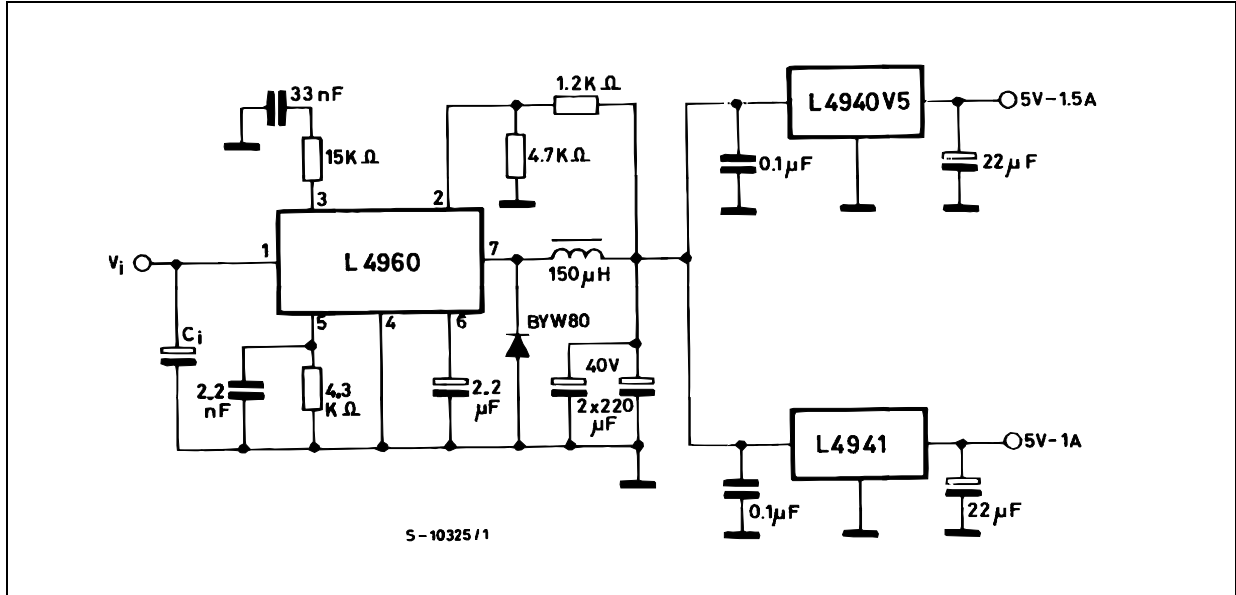
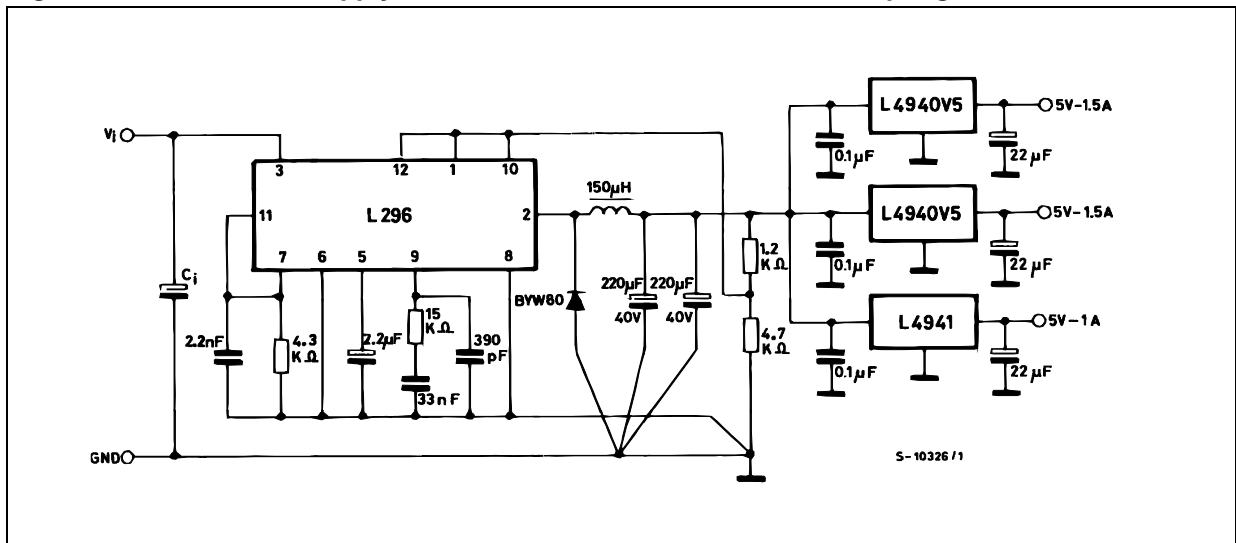

Figure 22. Distributed Supply with On-card L4940 and L4941 low drop regulator



ADVANTAGES OF THESE APPLICATION ARE:

On card regulation with short-circuit and thermal protection on each output.

Vary high total system efficiency due to the switching preregulation and very low-drop postregulation.

8 Package mechanical data

In order to meet environmental requirements, ST offers these devices in ECOPACK® packages. These packages have a Lead-free second level interconnect. The category of second Level Interconnect is marked on the package and on the inner box label, in compliance with JEDEC Standard JESD97. The maximum ratings related to soldering conditions are also marked on the inner box label. ECOPACK is an ST trademark. ECOPACK specifications are available at: www.st.com.

TO-220 MECHANICAL DATA

DIM.	mm.			inch		
	MIN.	TYP	MAX.	MIN.	TYP.	MAX.
A	4.40		4.60	0.173		0.181
C	1.23		1.32	0.048		0.051
D	2.40		2.72	0.094		0.107
D1		1.27			0.050	
E	0.49		0.70	0.019		0.027
F	0.61		0.88	0.024		0.034
F1	1.14		1.70	0.044		0.067
F2	1.14		1.70	0.044		0.067
G	4.95		5.15	0.194		0.203
G1	2.4		2.7	0.094		0.106
H2	10.0		10.40	0.393		0.409
L2		16.4			0.645	
L4	13.0		14.0	0.511		0.551
L5	2.65		2.95	0.104		0.116
L6	15.25		15.75	0.600		0.620
L7	6.2		6.6	0.244		0.260
L9	3.5		3.93	0.137		0.154
DIA.	3.75		3.85	0.147		0.151

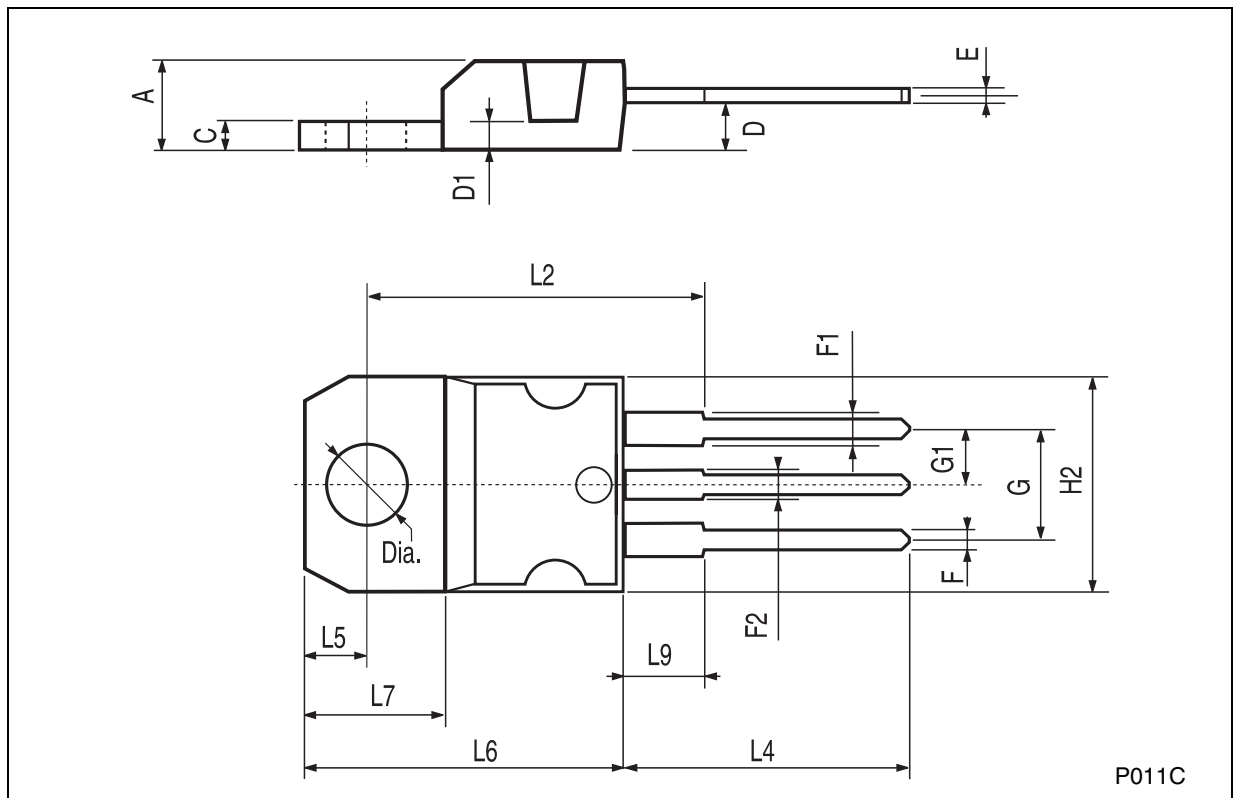

DPAK MECHANICAL DATA

DIM.	mm.			inch		
	MIN.	TYP	MAX.	MIN.	TYP.	MAX.
A	2.2		2.4	0.086		0.094
A1	0.9		1.1	0.035		0.043
A2	0.03		0.23	0.001		0.009
B	0.64		0.9	0.025		0.035
b4	5.2		5.4	0.204		0.212
C	0.45		0.6	0.017		0.023
C2	0.48		0.6	0.019		0.023
D	6		6.2	0.236		0.244
D1		5.1			0.200	
E	6.4		6.6	0.252		0.260
E1		4.7			0.185	
e		2.28			0.090	
e1	4.4		4.6	0.173		0.181
H	9.35		10.1	0.368		0.397
L	1			0.039		
(L1)		2.8			0.110	
L2		0.8			0.031	
L4	0.6		1	0.023		0.039
R		0.2			0.008	
V2	0°		8°	0°		8°

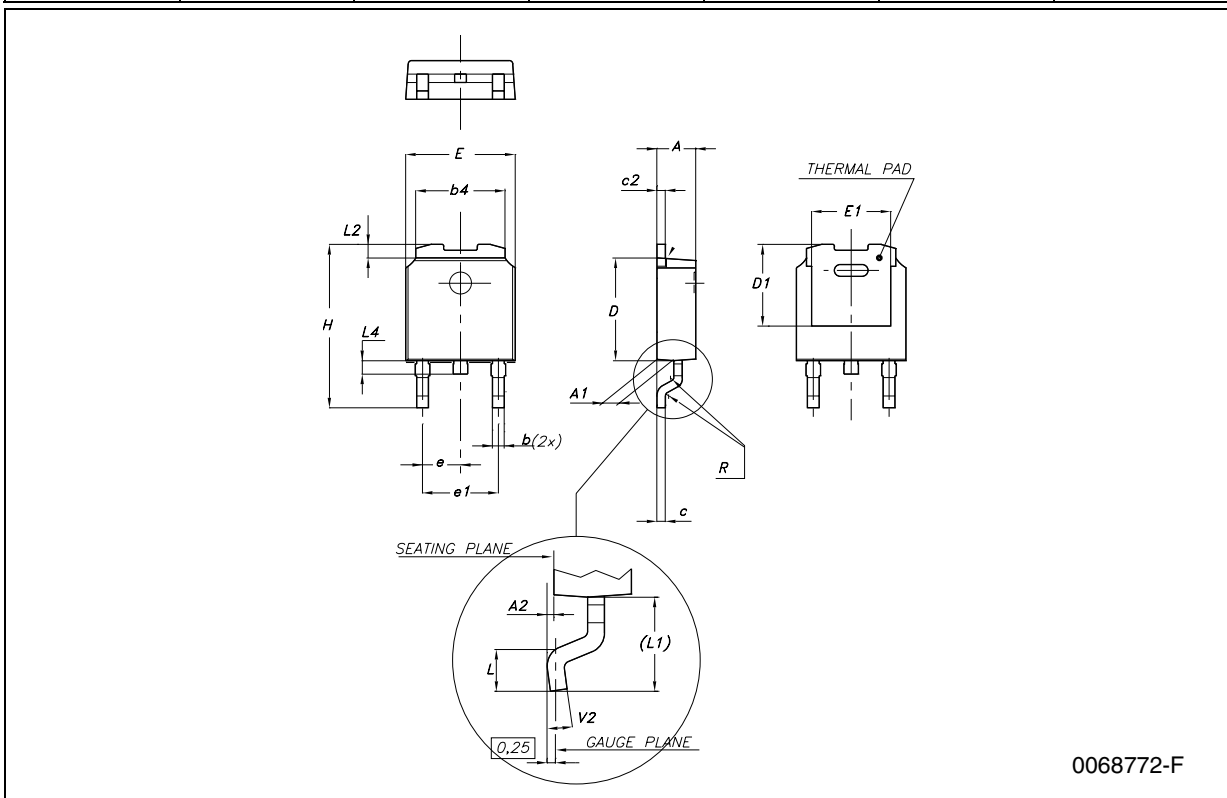

Tape & Reel DPAK-PPAK MECHANICAL DATA

DIM.	mm.			inch		
	MIN.	TYP	MAX.	MIN.	TYP.	MAX.
A			330			12.992
C	12.8	13.0	13.2	0.504	0.512	0.519
D	20.2			0.795		
N	60			2.362		
T			22.4			0.882
Ao	6.80	6.90	7.00	0.268	0.272	0.276
Bo	10.40	10.50	10.60	0.409	0.413	0.417
Ko	2.55	2.65	2.75	0.100	0.104	0.105
Po	3.9	4.0	4.1	0.153	0.157	0.161
P	7.9	8.0	8.1	0.311	0.315	0.319

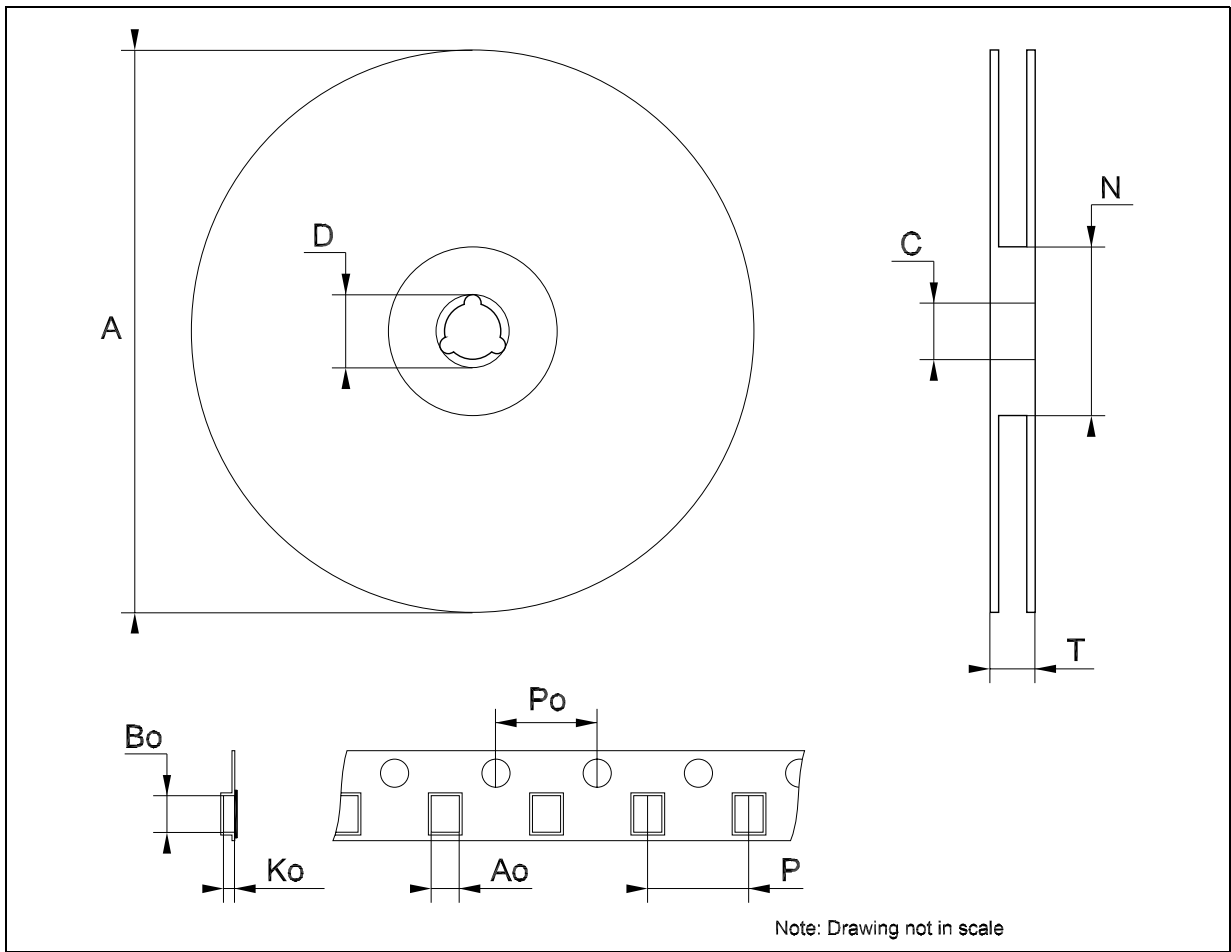

9 Revision history

Table 4. Revision history

Date	Revision	Changes
21-Jun-2004	4	Document updating.
15-Sep-2006	5	Order Codes has been updated and new template.

Please Read Carefully:

Information in this document is provided solely in connection with ST products. STMicroelectronics NV and its subsidiaries ("ST") reserve the right to make changes, corrections, modifications or improvements, to this document, and the products and services described herein at any time, without notice.

All ST products are sold pursuant to ST's terms and conditions of sale.

Purchasers are solely responsible for the choice, selection and use of the ST products and services described herein, and ST assumes no liability whatsoever relating to the choice, selection or use of the ST products and services described herein.

No license, express or implied, by estoppel or otherwise, to any intellectual property rights is granted under this document. If any part of this document refers to any third party products or services it shall not be deemed a license grant by ST for the use of such third party products or services, or any intellectual property contained therein or considered as a warranty covering the use in any manner whatsoever of such third party products or services or any intellectual property contained therein.

UNLESS OTHERWISE SET FORTH IN ST'S TERMS AND CONDITIONS OF SALE ST DISCLAIMS ANY EXPRESS OR IMPLIED WARRANTY WITH RESPECT TO THE USE AND/OR SALE OF ST PRODUCTS INCLUDING WITHOUT LIMITATION IMPLIED WARRANTIES OF MERCHANTABILITY, FITNESS FOR A PARTICULAR PURPOSE (AND THEIR EQUIVALENTS UNDER THE LAWS OF ANY JURISDICTION), OR INFRINGEMENT OF ANY PATENT, COPYRIGHT OR OTHER INTELLECTUAL PROPERTY RIGHT.

UNLESS EXPRESSLY APPROVED IN WRITING BY AN AUTHORIZED ST REPRESENTATIVE, ST PRODUCTS ARE NOT RECOMMENDED, AUTHORIZED OR WARRANTED FOR USE IN MILITARY, AIR CRAFT, SPACE, LIFE SAVING, OR LIFE SUSTAINING APPLICATIONS, NOR IN PRODUCTS OR SYSTEMS WHERE FAILURE OR MALFUNCTION MAY RESULT IN PERSONAL INJURY, DEATH, OR SEVERE PROPERTY OR ENVIRONMENTAL DAMAGE. ST PRODUCTS WHICH ARE NOT SPECIFIED AS "AUTOMOTIVE GRADE" MAY ONLY BE USED IN AUTOMOTIVE APPLICATIONS AT USER'S OWN RISK.

Resale of ST products with provisions different from the statements and/or technical features set forth in this document shall immediately void any warranty granted by ST for the ST product or service described herein and shall not create or extend in any manner whatsoever, any liability of ST.

ST and the ST logo are trademarks or registered trademarks of ST in various countries.

Information in this document supersedes and replaces all information previously supplied.

The ST logo is a registered trademark of STMicroelectronics. All other names are the property of their respective owners.

© 2006 STMicroelectronics - All rights reserved

STMicroelectronics group of companies

Australia - Belgium - Brazil - Canada - China - Czech Republic - Finland - France - Germany - Hong Kong - India - Israel - Italy - Japan - Malaysia - Malta - Morocco - Singapore - Spain - Sweden - Switzerland - United Kingdom - United States of America

www.st.com

AMEYA360

Components Supply Platform

Authorized Distribution Brand :



Website :

Welcome to visit www.ameya360.com

Contact Us :

➤ Address :

401 Building No.5, JiuGe Business Center, Lane 2301, Yishan Rd
Minhang District, Shanghai , China

➤ Sales :

Direct +86 (21) 6401-6692

Email amall@ameya360.com

QQ 800077892

Skype [ameyasales1](#) [ameyasales2](#)

➤ Customer Service :

Email service@ameya360.com

➤ Partnership :

Tel +86 (21) 64016692-8333

Email mkt@ameya360.com