

| REVISIONS |     |                        |          |     |      |
|-----------|-----|------------------------|----------|-----|------|
| REV       | ECO | DESCRIPTION            | DATE     | BY  | APPR |
| A3        | -   | RELEASE NEW DWG FORMAT | 06/07/13 | DRP | -    |

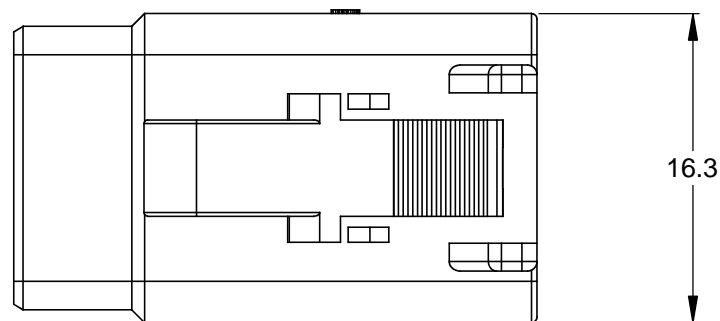

16.3

REQUIRES CONTACT RETENTION WEDGE AWM-3S

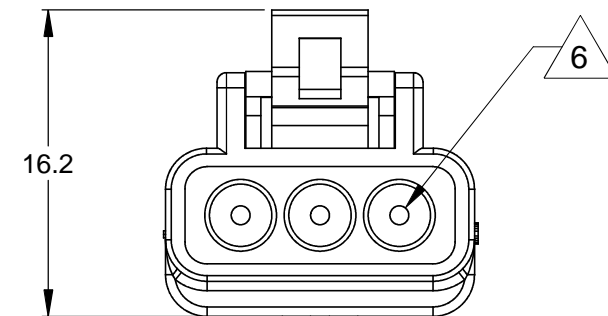
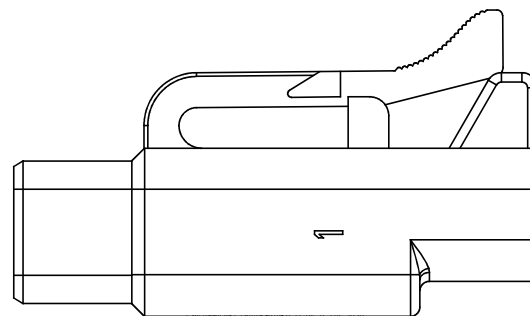
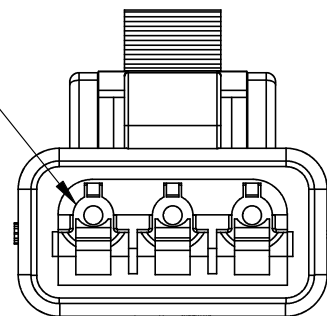

16.2

6

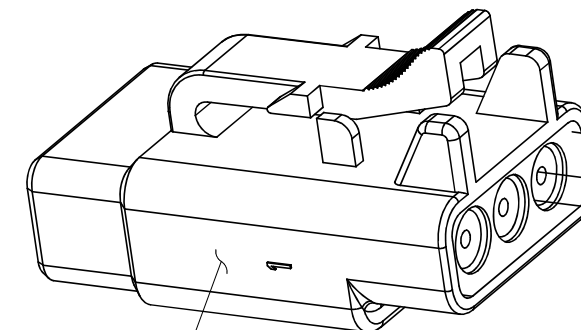

STANDARD MOLDED COLOR IS GREY. ADDITIONAL COLORS SHOWN IN PART NUMBER CHART ARE AVAILABLE VIA SPECIAL ORDER.

NOTES: UNLESS OTHERWISE SPECIFIED

- MATERIAL:  
HOUSING: THERMOPLASTIC  
SEAL: SILICONE RUBBER
- MODIFICATIONS: N/A
- SPECIFICATIONS:
  - CURRENT RATING: 7.5 AMPS
  - OPERATING TEMPERATURE: -55°C TO +125°C
  - DIELECTRIC WITHSTANDING VOLTAGE: LESS THAN 2 MILLIAMPS CURRENT LEAKAGE @ 1500 VOLTS AC.
  - INSULATION RESISTANCE: 1000 MEGOHMS MIN @ 25°C.
  - MOISTURE RESISTANCE: IP67 ( MATED CONDITION )
  - MATING CYCLE DURABILITY: 100 CYCLES
  - RoHS COMPLIANT
- MATING PART: ATM04-3P\* RECEPTACLE.  
(\* = MODIFICATIONS AND/OR COLORS )

5. ALL DIMENSIONS ARE FOR REFERENCE USE ONLY.

6 CONTACT SIZE AND REAR SEAL WIRE RANGE:

| CONTACT SIZE | MIN. INSUL O.D.   | MAX. INSUL O.D.   | TYPICAL WIRE RANGE |
|--------------|-------------------|-------------------|--------------------|
| 20           | 1.35 mm (.053 in) | 3.05 mm (.120 in) | 16 - 22 AWG        |

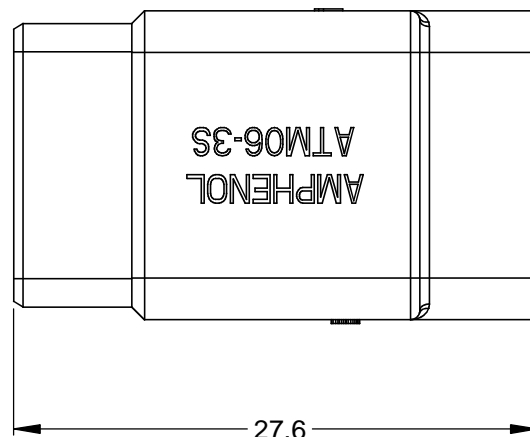

27.6

| PART NUMBER CHART |              |
|-------------------|--------------|
| COLOR             | PART NUMBER  |
| GREY              | ATM06-3S     |
| BLACK             | ATM06-3S-BLK |
| BLUE              | ATM06-3S-BLU |
| BROWN             | ATM06-3S-BRN |
| GREEN             | ATM06-3S-GRN |
| RED               | ATM06-3S-RED |
| WHITE             | ATM06-3S-WHT |
| YELLOW            | ATM06-3S-YEL |

| SEE PART NUMBER CHART   |             | DESCRIPTION    |              | ITEM   |
|---|-------------|----------------|--------------|--|
| QUANTITY  | PART NUMBER | MATERIALS LIST |              |  |
| UNLESS OTHERWISE SPECIFIED<br>1) All dimensions are in metric(mm).<br>2) Tolerances are as follows:<br>1 PL DEC ±0.30<br>2 PL DEC ±0.15<br>3 PL DEC ±0.08<br>Fractions ±1/64<br>Angles ±1°<br>3) Note reference = |             | SIGNATURES     | DATE         | <b>SINE Systems Corporation</b><br>A Subsidiary of Amphenol Corporation<br>44724 Morley Drive<br>Clinton Township, MI 48036<br><br><b>PLUG, 3 SOCKET, ATM SERIES</b>   |
| MATERIAL SPECIFICATIONS:  |             | DRAWN: D.PARKS | 06/07/13     |  |
| PROCESS SPECIFICATIONS:   |             | CHECKED:       | ENGINEER:    |  |
| NEXT ASSY:  |             | APPROVAL:      | CUSTOMER:    | THIS DRAWING IS SUPPLIED FOR INFORMATION ONLY. DESIGN FEATURES, SPECIFICATIONS AND PERFORMANCE DATA SHOWN HEREON ARE THE PROPERTY OF THE AMPHENOL CORPORATION. NO RIGHTS OF REPRODUCTION ARE IMPLIED. ALL DIMENSIONS ARE SUBJECT TO NORMAL MANUFACTURING VARIATIONS. |
| SCALE: NONE   | SIZE: B     | FSCM NO.:      | DWG NO.:     | REVISION: A3   |
|   |             |                | SHEET 1 OF 1 |  |

TITLE: PLUG, 3 SOCKET, ATM SERIES

DWG NO.: C- ATM06-3S-XXX

REV: A3

SH: 1

OF: 1

# AMEYA360

Components Supply Platform

Authorized Distribution Brand :



Website :

Welcome to visit [www.ameya360.com](http://www.ameya360.com)

Contact Us :

➤ Address :

401 Building No.5, JiuGe Business Center, Lane 2301, Yishan Rd  
Minhang District, Shanghai , China

➤ Sales :

Direct +86 (21) 6401-6692

Email [amall@ameya360.com](mailto:amall@ameya360.com)

QQ 800077892

Skype [ameyasales1](#) [ameyasales2](#)

➤ Customer Service :

Email [service@ameya360.com](mailto:service@ameya360.com)

➤ Partnership :

Tel +86 (21) 64016692-8333

Email [mkt@ameya360.com](mailto:mkt@ameya360.com)