

## 3 to 6 Series Cell Lithium-Ion Battery Monitor and Secondary Protection IC for EV and HEV Applications

Check for Samples: [bq76PL536](#)

### FEATURES

- 3 to 6 Series Cell Support, All Chemistries
- Hot-Pluggable
- High-Speed SPI for Data Communications
- Stackable Vertical Interface
- No Isolation Components Required Between ICs
- Industrial Temperature Range,  $-40^{\circ}\text{C}$  to  $85^{\circ}\text{C}$
- High-Accuracy Analog-to-Digital Converter (ADC):
  - $\pm 3$  mV Typical accuracy
  - 14-Bit Resolution, 6- $\mu\text{s}$  Conversion Time
  - Nine ADC Inputs: 6 Cell Voltages, 1 Six-Cell Brick Voltage, 2 Temperatures, 1 General-Purpose Input
  - Dedicated Pins for Synchronizing Measurements
- Configuration Data Stored in ECC-OTP Registers
- Built-In Comparators (Secondary Protector) for:
  - Over- and Undervoltage Protection
  - Overtemperature Protection
  - Programmable Thresholds and Delay Times
  - Dedicated Fault Output Signals for OV, UV, OT
- Cell Balancing Control Outputs With Safety Timeout
  - Balance Current Set by External Components
- Supply Voltage Range from 6 V to 30 V Continuous and 36 V Peak
- Low Power:
  - Typical 12- $\mu\text{A}$  Sleep, 45- $\mu\text{A}$  Idle
- Integrated Precision 5-V, 3-mA LDO

### APPLICATIONS

- Uninterruptible Power Systems (UPS)
- E-Bike and E-Scooter
- Large-Format Battery Systems
- Electric and Hybrid Electric Vehicles

### DESCRIPTION

The bq76PL536 is a stackable three to six series cell lithium-ion battery pack protector and analog front end (AFE) that incorporates a precision analog-to-digital converter (ADC); independent cell voltage and temperature protection; cell balancing, and a precision 5-V regulator to power user circuitry.

The bq76PL536 integrates a voltage translation and precision analog-to-digital converter system to measure battery cell voltages with high accuracy and speed.

The bq76PL536 provides full protection (secondary protection) for overvoltage, undervoltage, and overtemperature conditions. When safety thresholds are exceeded, the bq76PL536 sets the FAULT output. No external components are needed to configure or enable the protection features.

Cell voltage and temperature protection functions are independent of the ADC system. Programmable protection thresholds and detection delay times are stored in Error Check/Correct (ECC) OTP EPROM, which increases the flexibility and reliability of the battery management system.

The bq76PL536 is intended to be used with a host controller to maximize the functionality of the battery management system. However, the protection functions do not require a host controller.

The bq76PL536 can be stacked vertically to monitor up to 192 cells without additional isolation components between ICs. A high-speed serial peripheral interface (SPI) bus operates between each bq76PL536 to provide reliable communications through a high-voltage battery cell stack.



Please be aware that an important notice concerning availability, standard warranty, and use in critical applications of Texas Instruments semiconductor products and disclaimers thereto appears at the end of this data sheet.

PowerPAD is a trademark of Texas Instruments.

# bq76PL536

SLUSA08A –DECEMBER 2009–REVISED JULY 2010

www.ti.com



These devices have limited built-in ESD protection. The leads should be shorted together or the device placed in conductive foam during storage or handling to prevent electrostatic damage to the MOS gates.

## DESCRIPTION (CONTINUED)

The host microcontroller controls cell balancing of individual cells by setting the registers (via SPI) which control the appropriate CBx outputs. These outputs can be turned off via the same control, or automatically by the internal programmable safety timer. The balancing bypass current is set via an external series resistor and FET.

## TYPICAL IMPLEMENTATION

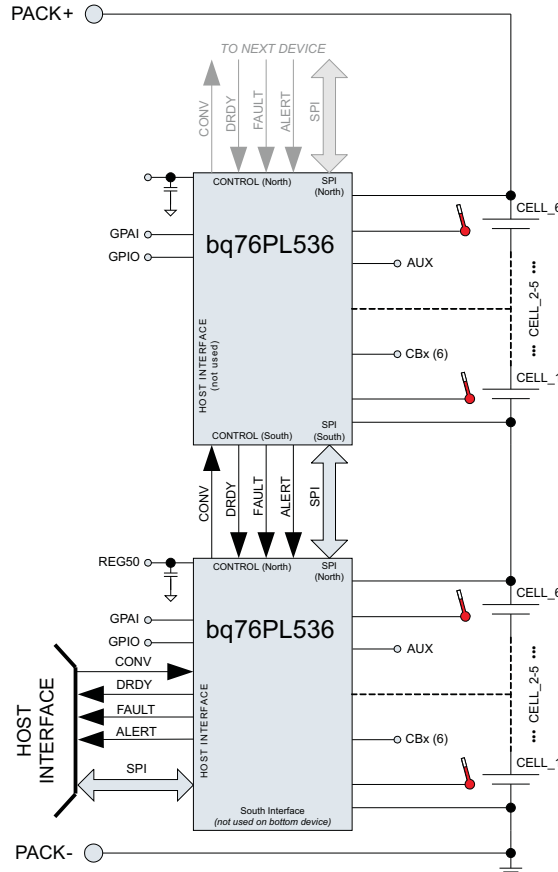

**Figure 1. Simplified System Connection**

## PIN DETAILS

### PIN FUNCTIONS

NO.	PIN NAME	TYPE <sup>(1)</sup>	DESCRIPTION
2	CB6	O	Cell-balance control output
3	VC5	AI	Sense voltage input terminal for the positive terminal of the fifth cell
4	CB5	O	Cell-balance control output
5	VC4	AI	Sense voltage input terminal for the positive terminal of the fourth cell
6	CB4	O	Cell-balance control output

(1) Key: I = digital input, AI = analog input, O = digital output, OD = open-drain output, T = 3-state output, P = power.

NO.	PIN		TYPE <sup>(1)</sup>	DESCRIPTION
	NAME			
7	VC3	AI		Sense voltage input terminal for the positive terminal of the third cell
8	CB3	O		Cell-balance control output
9	VC2	AI		Sense voltage input terminal for the positive terminal of the second cell
10	CB2	O		Cell-balance control output
11	VC1	AI		Sense voltage input terminal for positive terminal of the first cell
12	CB1	O		Cell-balance control output
13	VC0	AI		Sense-voltage input terminal for negative terminal of first cell (VSS)
14	VSS1	P		V <sub>SS</sub>
15	AGND	AI		Internal analog V <sub>REF</sub> (-)
16	VREF	P		Internal analog voltage reference (+), requires 10-μF, low-ESR ceramic capacitor to AGND for stability
17	LDOA	P		Internal analog 5-V LDO bypass connection, requires 2.2-μF ceramic capacitor for stability
18	LDOD1	P		Internal digital 5-V LDO bypass connection 1, requires 2.2-μF ceramic capacitor for stability. This pin is tied internally to LDOD2. This pin should be tied to LDOD2 externally.
19	TS1-	AI		Differential temperature sensor input
20	TS1+	AI		Differential temperature sensor input
21	CONV_S	I		Input from the adjacent lower bq76PL536 to initiate a conversion
22	DRDY_S	OD		Current-mode output indicating conversion data is ready to the next lower bq76PL536
23	ALERT_S	OD		Current-mode output indicating a system status change to the next lower bq76PL536
24	FAULT_S	OD		Current-mode output
25	VSS2	P		VSS
26	SCLK_S	I		Current-mode input SPI clock from the next-lower bq76PL536
27	SDO_S	OD		Current-mode output for SPI data to the next-lower bq76PL536
28	SDI_S	I		Current-mode input for SPI data from the next-lower bq76PL536
29	CS_S	I		Current-mode input SPI chip-select (slave-select) from the next-lower bq76PL536
30	NC	-		No connection
31	AUX	O		Switched 1-mA limited output from REG50
32	REG50	P		5-V user LDO output, requires 2.2-μF ceramic capacitor for stability
33	VSS3	P		VSS
34	VSS4	P		VSS
35	VSS5	P		VSS
36	CONV_H	I		Host-to-device interface – initiates a synchronous conversion. Pin has 250-nA internal sink to VSS.
37	DRDY_H	O		Host-to-device interface – conversion complete, data-ready indication
38	ALERT_H	O		Host-to-device interface – ALERT condition detected in this or higher (North) device
39	FAULT_H	O		Host-to-device interface – FAULT condition detected in this or higher (North) device
40	SCLK_H	I		Host-to-device interface – SPI clock from host
41	SDO_H	O		Host-to-device interface – data from device to host (host MISO signal), 3-state pin, 250-nA internal pullup
42	SDI_H	I		Host-to-device interface – data from host to device (host MOSI signal)
43	CS_H	I		Host-to-device interface – active-low chip select from host. Internal 100-kΩ pullup resistor
44	HSEL	I		Host interface enable, 0 = enable, 1 = disable
45	GPIO	IOD		Digital open-drain I/O. A 10 kΩ–2-MΩ pullup is recommended.
46	LDOD2	P		Internal digital 5-V LDO bypass connection 2, requires 2.2-μF ceramic capacitor for stability. This pin is tied internally to LDOD1. This pin should be tied to LDOD1 externally.
47	GPAI-	AI		General-purpose (differential) analog input, connect to VSS if unused.
48	GPAI+	AI		General-purpose (differential) analog input, connect to VSS if unused.
49	VSS6	P		V <sub>SS</sub>
50	TEST	I		Factory Test pin. Connect to VSS in user circuitry. This pin includes ~100K internal pull-down
51	NC	-		No connect
52	CS_N	OD		Current-mode output used to select the next-higher bq76PL536 for SPI communication

# bq76PL536

SLUSA08A –DECEMBER 2009–REVISED JULY 2010

[www.ti.com](http://www.ti.com)

NO.	PIN		DESCRIPTION
	NAME	TYPE <sup>(1)</sup>	
53	SDI_N	OD	Current-mode output for SPI data to the next-higher bq76PL536
54	SDO_N	I	Current-mode input for SPI data from the next-lower bq76PL536
55	SCLK_N	OD	Current-mode output SPI clock to the next-higher bq76PL536
56	FAULT_N	I	Current-mode input indicating a system status change from the next-higher bq76PL536
57	ALERT_N	I	Current-mode input indicating a system status change from the next-higher bq76PL536
58	DRDY_N	I	Current-mode input indicating conversion data is ready from next-higher bq76PL536
59	CONV_N	OD	Current-mode output to the next-higher bq76PL536 to initiate a conversion
60	TS2-	AI	Differential temperature sensor input
61	TS2+	AI	Differential temperature sensor input
62	NC	–	No connect
63	BAT1	P	Power-supply voltage, connect to most positive cell +, tie to BAT2 on PCB
64	BAT2	P	Power-supply voltage, connect to most positive cell +, tie to BAT1 on PCB
65	TAB	–	Tab on bottom of PowerPAD™ package, this must be soldered to similar-size copper area on PCB, connected to VSS, to meet stated specifications herein. Provides heat-sinking to part.

## PINOUT DIAGRAM

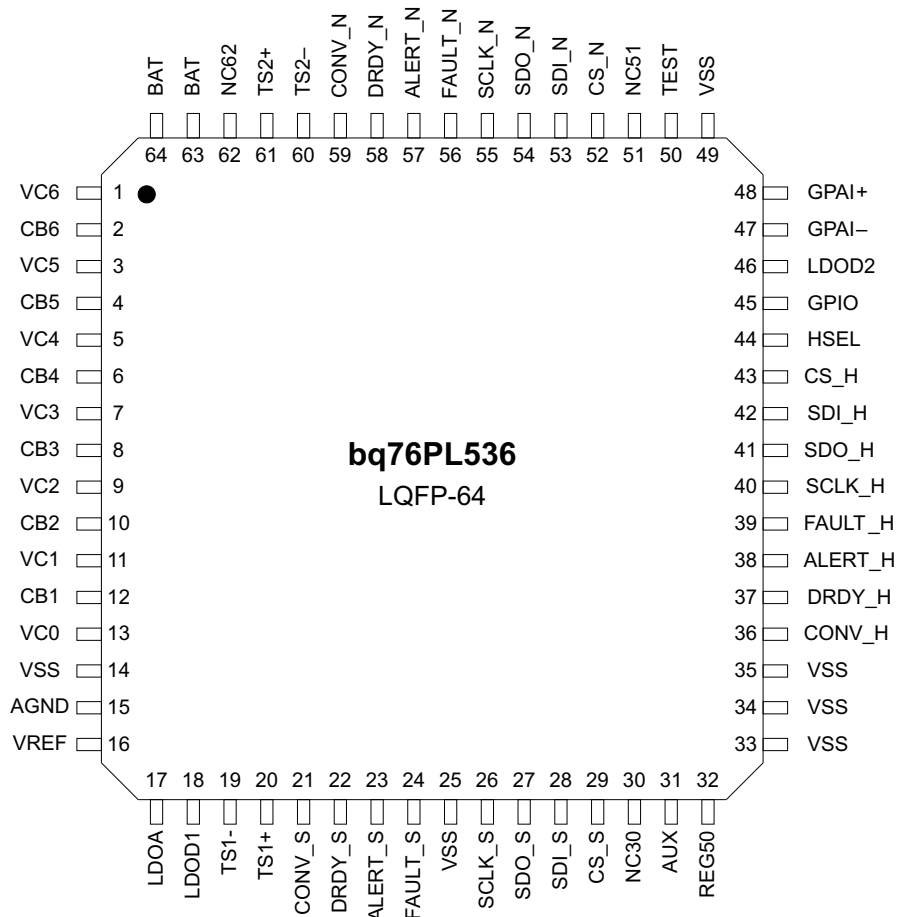

ORDERING INFORMATION

T <sub>A</sub>	PACKAGE	PART NO.
-40°C To 85°C	64 TQFP PowerPAD package	bq76PL536PAP <sup>(1)</sup>

(1) The bq76PL536 can be ordered in tape and reel as bq76PL536PAPR (quantity 1000) or bq76PL536PAPT (quantity 250).

FUNCTIONAL BLOCK DIAGRAM

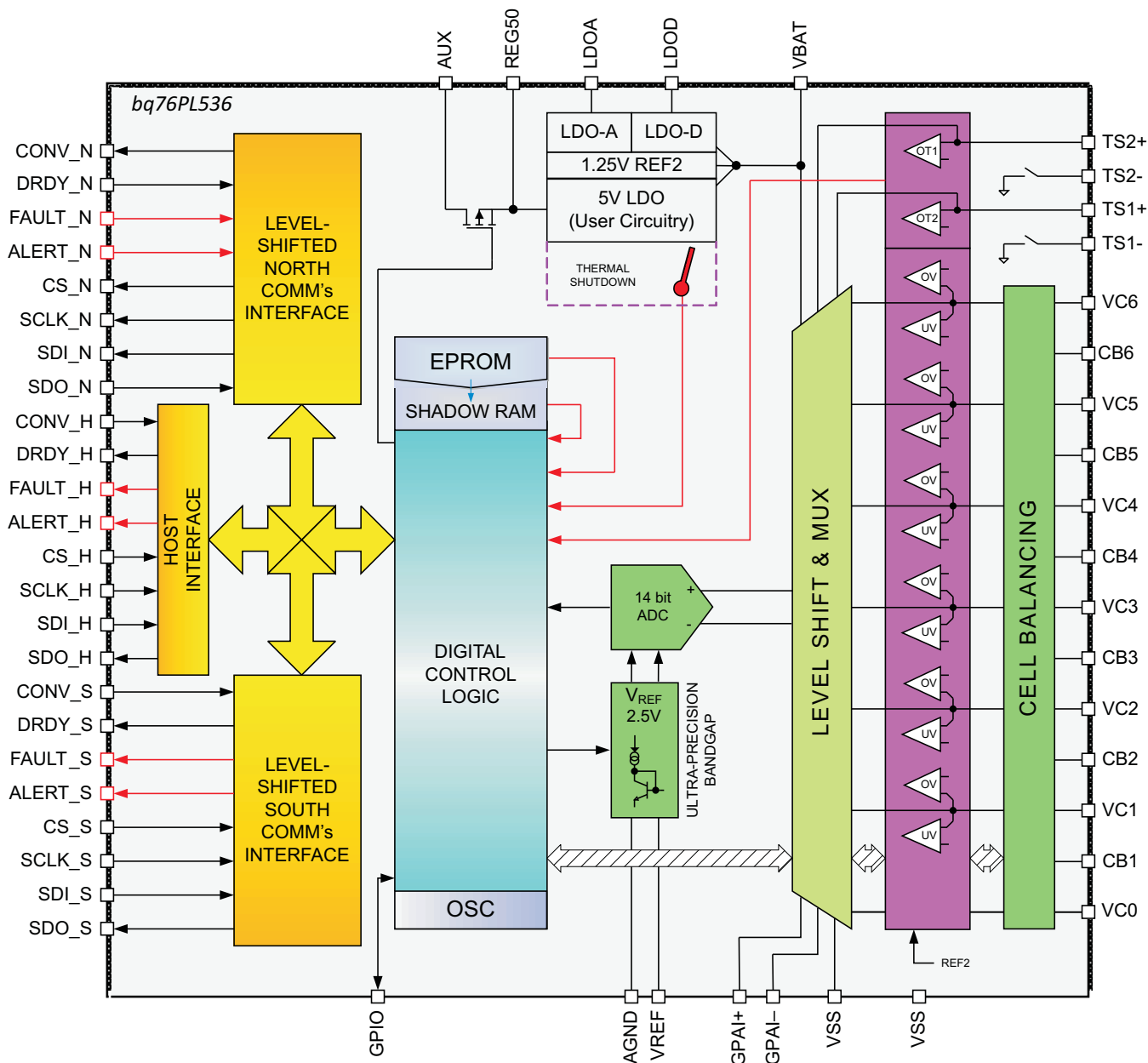

Figure 2. bq76PL536 Block Diagram

## ABSOLUTE MAXIMUM RATINGS

 over operating free-air temperature range (unless otherwise noted) <sup>(1)</sup>

		VALUE	UNIT
Supply voltage range, $V_{MAX}$	BAT1 <sup>(2)</sup>	-0.3 to 36	V
BAT voltage to any other pin	BAT to any pin	-0.3 to 36	V
Input voltage range, $V_{IN}$	VC1–VC6	-0.3 to 36	V
	VC0	-0.3 to 2	
	VCn to VCn-1, n=1 to 6	0 to 36	
	TS1+, TS1-, TS2+, TS2-	-0.3 V to 6	
	GPAI	-0.3 to 6	
	GPIO	-0.3 to $V_{REG50} + 0.3$	
	DRDY_N, SDO_N, FAULT_N, ALERT_N	-0.3 to 36	
	CONV_S, SDI_S, SCLK_S, CS_S	-2 to 1	
Output voltage range, $V_O$	CONV_N, SDI_N, SCLK_N, CS_N	-0.3 to 36	V
	DRDY_S, SDO_S, FAULT_S, ALERT_S	-0.3 to 5	
	GPIO	-0.3 to $V_{REG50} + 0.3$	
	CB1...CB6 (CBREF = 0x00)	-0.3 to 36	
	REG50, AUX	-0.3 to 6	
Junction temperature		150	°C
Storage temperature range, $T_{STG}$		-65 to 150	°C

- (1) Stresses beyond those listed under *Absolute Maximum Ratings* may cause permanent damage to the device. These are stress ratings only; functional operation of the device at these or any other conditions beyond those indicated under *Recommended Operating Conditions* is not implied. Exposure to absolute-maximum-rated conditions for extended periods may affect device reliability.
- (2) All voltages are with respect to VS of this device except VCn–VC(n+1), where n = 1 to 6 cell voltage.

## RECOMMENDED OPERATING CONDITIONS

 Typical values stated where  $T_A = 25^\circ\text{C}$  and BAT = 20 V, Min/Max values stated where  $T_A = -40^\circ\text{C}$  to  $85^\circ\text{C}$  and BAT = 7.2 V to 30 V (unless otherwise noted)

			MIN	NOM	MAX	UNIT
$V_{BAT}$	Supply voltage	BAT	7.2		27	V
$V_I$	Input voltage range	VCn–VC(n – 1) <sup>(1)</sup>	1		4.5	V
		GPAI	0		$V_{REG50}$	
		GPIO	0		$V_{REG50}$	
		CBn <sup>(1)</sup>	$VC(n - 1)$		$VCn$	
		TS1+, TS1-, TS2+, TS2-	0		$V_{REG50}/2$	
		DRDY_N, SDO_N, FAULT_N, ALERT_N		BAT + 1		
		CONV_S, SDI_S, SCLK_S, CS_S		-1		
$V_O$	Output voltage range	CONV_N, SDI_N, SCLK_N, CS_N		BAT – 1		V
		DRDY_S, SDO_S, FAULT_S, ALERT_S		1		
$C_{REG50}$	External capacitor	REG50 pin	2.2			µF
$C_{VREF}$	External capacitor	$V_{REF}$ pin	9.2	10	15	µF
$C_{LDO}$	External capacitor	LDOx pin	2.2		3.3	µF
$T_{OPR}$	Operating temperature <sup>(2)</sup>		-40		85	°C

- (1) n = 1 to 6  
 (2) Device specifications stated within this range.

## ELECTRICAL CHARACTERISTICS

### SUPPLY CURRENT

Typical values stated where  $T_A = 25^\circ\text{C}$  and  $BAT = 20\text{ V}$ , Min/Max values stated where  $T_A = -40^\circ\text{C}$  to  $85^\circ\text{C}$  and  $BAT = 7.2\text{ V}$  to  $27\text{ V}$  (unless otherwise noted)

PARAMETER		TEST CONDITION	MIN	TYP	MAX	UNIT
$I_{CC\text{SLEEP}}$	Supply current	No load at REG50, SCLK_N, SDI_N, SDO_N, FAULT_N, CONV_N, DRDY_S, ALERT_N, TSx, AUX, or CBx; CB_CTRL = 0; CBT_CONTROL = 0; CONV_H = 0 (not converting), IO_CTRL[SLEEP] = 1		12	20	$\mu\text{A}$
$I_{CC\text{PROTECT}}$	Supply current	No load at REG50, SCLK_N, SDI_N, SDO_N, FAULT_N, CONV_N, DRDY_S, ALERT_N, TSx, AUX, or CBx; CB_CTRL = 0; CBT_CONTROL = 0; CONV_H = 0 (not converting), IO_CTRL[SLEEP] = 0		45	60	$\mu\text{A}$
$I_{CC\text{BALANCE}}$	Supply current	No load at REG50, SCLK_N, SDI_N, SDO_N, FAULT_N, CONV_N, DRDY_S, ALERT_N, TSx, or AUX; No DC load at CBx; CB_CTRL $\neq$ 0; CBT_CONTROL $\neq$ 0; CONV_H = 0 (not converting), IO_CTRL[SLEEP] = 0		46	60	$\mu\text{A}$
$I_{CC\text{CONVERT}}$	Supply current	No load at REG50, SCLK_N, SDI_N, SDO_N, FAULT_N, CONV_N, DRDY_S, ALERT_N, TSx or CBx; CONV_S = 1 (conversion active), IO_CTRL[SLEEP] = 0		10.5	15	$\text{mA}$
$I_{CC\text{TSD}}$	Supply current	Thermal shutdown activated; ALERT_STATUS[TSD] = 1; Device die temperature $\geq 100^\circ\text{C}$		1.6	2.2	$\text{mA}$

### REG50, INTEGRATED 5-V LDO

Typical values stated where  $T_A = 25^\circ\text{C}$  and  $BAT = 20\text{ V}$ , Min/Max values stated where  $T_A = -40^\circ\text{C}$  to  $85^\circ\text{C}$  and  $BAT = 7.2\text{ V}$  to  $27\text{ V}$  (unless otherwise noted)

PARAMETER		TEST CONDITION	MIN	TYP	MAX	UNIT
$V_{\text{REG50}}$	Output voltage	$I_{\text{REG50OUT}} \leq 0.5\text{ mA}$ , $C = 2.2\ \mu\text{F}$ to $22\ \mu\text{F}$	4.9	5	5.1	V
$\Delta V_{\text{REG50LINE}}$	Line regulation	$6\text{ V} \leq \text{BAT} \leq 27\text{ V}$ , $I_{\text{REG50OUT}} = 2\text{ mA}$		10	25	mV
$\Delta V_{\text{REG50LOAD}}$	Load regulation	$0.2\text{ mA} \leq I_{\text{REG50OUT}} \leq 2\text{ mA}$			15	mV
		$0.2\text{ mA} \leq I_{\text{REG50OUT}} \leq 5\text{ mA}$			25	
$I_{\text{REG50MAX}}$	Current limit		12	25	35	$\text{mA}$
$I_{\text{AUXMAX}}$	Current limit				5	$\text{mA}$
$R_{\text{AUX}}$	AUX output	$I = 1\text{ mA}$ , max. capacitance = $V_{\text{REG50}}$ Capacitor: $C_{\text{VAUX}} \leq C_{\text{VREG50}} / 10$			50	$\Omega$

### LEVEL SHIFT INTERFACE

Typical values stated where  $T_A = 25^\circ\text{C}$  and  $BAT = 20\text{ V}$ , Min/Max values stated where  $T_A = -40^\circ\text{C}$  to  $85^\circ\text{C}$  and  $BAT = 7.2\text{ V}$  to  $27\text{ V}$  (unless otherwise noted)

PARAMETER		TEST CONDITION	MIN	TYP	MAX	UNIT
$I_{\text{NTX1}}$	North 1 transmitter current	SCLK_N, CS_N, SDI_N, CONV_N	-755	-840	-1020	$\mu\text{A}$
$I_{\text{NTX0}}$	North 0 transmitter current	SCLK_N, CS_N, SDI_N, CONV_N			-1	$\mu\text{A}$
$I_{\text{SRX}}$	South 1 receiver current	SCLK_S, CS_S, SDI_S, CONV_S	525	620	665	$\mu\text{A}$
$I_{\text{STX1}}$	South 1 transmitter current	SDO_S, ALERT_N, FAULT_S, DRDY_S	925	1040	1200	$\mu\text{A}$
$I_{\text{STX0}}$	South 0 transmitter current	SDO_S, ALERT_S, FAULT_S, DRDY_S			1	$\mu\text{A}$
$I_{\text{NRX}}$	North 1 receiver current	SDO_N, ALERT_N, FAULT_N, DRDY_N	-350	-420	-580	$\mu\text{A}$
$C_{\text{IN}}$	Input capacitance <sup>(1)</sup>			15		$\text{pF}$

(1) Specified by design, not tested in production.

# bq76PL536

SLUSA08A –DECEMBER 2009–REVISED JULY 2010

www.ti.com

## HOST INTERFACE

Typical values stated where  $T_A = 25^\circ\text{C}$  and  $BAT = 20\text{ V}$ , Min/Max values stated where  $T_A = -40^\circ\text{C}$  to  $85^\circ\text{C}$  and  $BAT = 7.2\text{ V}$  to  $27\text{ V}$  (unless otherwise noted)

PARAMETER		TEST CONDITION	MIN	TYP	MAX	UNIT
$V_{OH}$	Logic-level output voltage, high; SDO_H, FAULT_H, ALERT_H, DRDY	$C_L = 20\text{ pF}$ , $I_{OH} < 5\text{ mA}$ <sup>(1)</sup>	4.5		$V_{LDOD}$	V
$V_{OL}$	Logic-level output voltage, low; SDO_H, FAULT_H, ALERT_H, DRDY	$C_L = 20\text{ pF}$ , $I_{OL} < 5\text{ mA}$	VSS		0.5	V
$V_{IH}$	Logic-level input voltage, high; SCLK_H, SDI_H, CS_H, CONV		2		5.2	V
$V_{IL}$	Logic-level input voltage, low; SCLK_H, SDI_H, CS_H, CONV		VSS		0.8	V
$C_{IN}$	Input capacitance <sup>(2)</sup> SCLK_H, SDI_H, CS_H, CONV			5		pF
$I_{LKG}$	Input leakage current <sup>(2)</sup> SCLK_H, SDI_H, CS_H, CONV				1	$\mu\text{A}$

(1) Total simultaneous current drawn from all pins is limited by LDOD current to  $\leq 10\text{ mA}$ .

(2) Specified by design, not tested in production.

## GENERAL PURPOSE INPUT/OUTPUT (GPIO)

Typical values stated where  $T_A = 25^\circ\text{C}$  and  $BAT = 20\text{ V}$ , Min/Max values stated where  $T_A = -40^\circ\text{C}$  to  $85^\circ\text{C}$  and  $BAT = 7.2\text{ V}$  to  $27\text{ V}$  (unless otherwise noted)

PARAMETER		TEST CONDITION	MIN	TYP	MAX	UNIT
$V_{IH}$	Logic-level input voltage, high	$V_{in} \leq V_{REG50}$	2			V
$V_{IL}$	Logic-level input voltage, low				0.8	V
$V_{OH}$	Output high-voltage pullup voltage	Supplied by external $\sim 100\text{K}$ resistor			$V_{REG50}$	V
$V_{OL}$	Logic-level output voltage, low	$I_{OL} = 1\text{ mA}$	0.3			V
$C_{IN}$	Input capacitance(1)			5		pF
$I_{LKG}$	Input leakage current				1	$\mu\text{A}$

## CELL BALANCING CONTROL OUTPUT (CBx)

Typical values stated where  $T_A = 25^\circ\text{C}$  and  $BAT = 20\text{ V}$ , Min/Max values stated where  $T_A = -40^\circ\text{C}$  to  $85^\circ\text{C}$  and  $BAT = 7.2\text{ V}$  to  $27\text{ V}$  (unless otherwise noted)

PARAMETER		TEST CONDITIONS	MIN	TYP	MAX	UNIT
$CB_z$	Output impedance	$1\text{ V} < V_{CELL} < 5\text{ V}$	80	100	120	$\text{k}\Omega$
$V_{RANGE}$	Output V		$V_{Cn-1}$		$V_{Cn}$	V

## ANALOG-TO-DIGITAL CONVERTER

### ADC Common Specifications

Typical values stated where  $T_A = 25^\circ\text{C}$  and  $BAT = 20\text{ V}$ , Min/Max values stated where  $T_A = -40^\circ\text{C}$  to  $85^\circ\text{C}$  and  $BAT = 7.2\text{ V}$  to  $27\text{ V}$  (unless otherwise noted)

PARAMETER		TEST CONDITION	MIN	TYP	MAX	UNIT
$t_{CONV\_START}$	CONV high to conversion start <sup>(1)</sup> , <sup>(2)</sup> , <sup>(3)</sup>	ADC_CONTROL[ADC_ON] = 1	5.4	6	6.6	$\mu\text{s}$
		ADC_CONTROL[ADC_ON] = 0		500		$\mu\text{s}$
$t_{CONV}$	Conversion time per selected channel <sup>(4)</sup> , <sup>(3)</sup>	ADC_CONTROL[ADC_ON] = 1 FUNCTION_CONFIG[ADCTx]=00	5.4	6	6.6	$\mu\text{s}$
$I_{LKG}$	Input leakage current	Not converting		<10	100	nA

(1) If ADC\_CONTROL[ADC\_ON] = 0, add 500  $\mu\text{s}$  to conversion time to allow ADC subsystem to stabilize. This is self-timed by the part.

(2) Additional 50 ms (POR) required before first conversion after a) initial cell connection; or b)  $V_{BAT}$  falls below  $V_{POR}$

(3) ADC specifications valid when device is programmed for 6- $\mu\text{s}$  conversion time per channel, FUNC\_CONFIG[ADCT1:0] = 01b.

(4) Plus TCONV\_START, i.e., if device is programmed for six channel conversions, total time is approximately  $6 \times 6 + 6 = 42\text{ }\mu\text{s}$ .



## VCn (Cell) Inputs

Typical values stated where  $T_A = 25^\circ\text{C}$  and  $BAT = 20\text{V}$ , Min/Max values stated where  $T_A = -40^\circ\text{C}$  to  $85^\circ\text{C}$  and  $BAT = 7.2\text{V}$  to  $27\text{V}$  (unless otherwise noted),  $FUNCTION\_CONFIG[] = 01xxxx00b$  for all test conditions (6- $\mu\text{s}$  conversion time selected).

PARAMETER		TEST CONDITIONS	MIN	TYP	MAX	UNIT
$V_{IN}$	Input voltage range <sup>(1)</sup>	$VCn - VCn-1$ , where $n = 1$ to $6$	0		6	V
$V_{RES}$	Voltage resolution <sup>(2)</sup>	14 bits		~378		$\mu\text{V}$
$V_{ACC}$	Voltage accuracy, measured value, $V_{IN} = VCn$ to $VCn-1$	$0.5\text{V} < V_{IN} < 2.5\text{V}$	-0.25%	$\pm 0.1\%$	0.25%	
		$2.5\text{V} \leq V_{IN} \leq 5\text{V}$	-0.2%	$\pm 0.1\%$	0.2%	
$R_{IN}$	Effective input resistance	Converting		2		$\text{M}\Omega$
$C_{IN}$	Input capacitance <sup>(3)</sup>	Converting		40		pF
$E_N$	Noise <sup>(4)</sup>	$V_{IN} = 3\text{V}$			<250	$\mu\text{V}_{RMS}$

- (1) 0 V may not lie within the range of measured values due to offset voltage limit and device calibration.
- (2) See text for specific conversion formula.
- (3) ADC is factory trimmed at the conversion speed of ~6  $\mu\text{s}$ /channel ( $FUNC\_CONFIG[ADCT1:0] = 01b$ ). Use of a different conversion-speed setting may affect measurement accuracy.
- (4) Specified by design, not measured in production

## $V_{BAT}$ ( $V_{BRICK}$ ) Measurement

Typical values stated where  $T_A = 25^\circ\text{C}$  and  $BAT = 20\text{V}$ , Min/Max values stated where  $T_A = -40^\circ\text{C}$  to  $85^\circ\text{C}$  and  $BAT = 7.2\text{V}$  to  $27\text{V}$  (unless otherwise noted),  $FUNCTION\_CONFIG[] = 01xxxx00b$  for all test conditions

PARAMETER		TEST CONDITION	MIN	TYP	MAX	UNIT
$V_{IN}$	Input voltage range <sup>(1)</sup> , $BATn$ to $VSS$	$FUNCTION\_CONFIG[] = 0101xx00b$	0		30	V
$V_{RES}$	Voltage resolution <sup>(2)</sup>	14 bits		~1.831		mV
$V_{ACC}$	Voltage accuracy, <sup>(3)</sup> $V_{IN} = BAT - VSS$	$6\text{V} < V_{IN} < 18\text{V}$	-0.6%	$\pm 0.3\%$	0.6%	
		$18\text{V} \leq V_{IN} \leq 27\text{V}$	-0.4%	$\pm 0.2\%$	0.4%	
$C_{IN}$	Input capacitance <sup>(4)</sup>	Converting		40		pF
$R_{IN}$	Effective input resistance	Converting		50		$\text{k}\Omega$
$E_N$	Noise <sup>(4)</sup>				<1.5	$\text{mV}_{RMS}$

- (1) 0 V may not lie within the range of measured values due to offset voltage limit and device calibration.
- (2) See text for specific conversion formula.
- (3) ADC is factory trimmed at the conversion speed of ~6  $\mu\text{s}$ /channel ( $FUNC\_CONFIG[ADCT1:0] = 01b$ ). Use of a different conversion-speed setting may affect measurement accuracy.
- (4) Specified by design, not measured in production

## GPAI Measurement

Typical values stated where  $T_A = 25^\circ\text{C}$  and  $BAT = 20\text{V}$ , Min/Max values stated where  $T_A = -40^\circ\text{C}$  to  $85^\circ\text{C}$  and  $BAT = 7.2\text{V}$  to  $27\text{V}$  (unless otherwise noted),  $FUNCTION\_CONFIG[] = 0101xx00b$  for all test conditions

PARAMETER		TEST CONDITION	MIN	TYP	MAX	UNIT
$V_{IN}$	Input voltage range, <sup>(1)</sup> $GPAI+$ to $GPAI-$		0		2.5	V
$V_{RES}$	Voltage resolution <sup>(2)</sup>	14 bits		~153		$\mu\text{V}$
$V_{ACC}$	Voltage accuracy, <sup>(3)</sup> $V_{IN} = GPAI+ - GPAI-$	$0.25\text{V} \leq V_{IN} \leq 2.5\text{V}$	-0.2%	$\pm 0.1\%$	0.2%	
$C_{IN}$	Input capacitance <sup>(4)</sup>	Converting		40		pF
$R_{IN}$	Effective input resistance	Converting		50		$\text{k}\Omega$
$E_N$	Noise <sup>(4)</sup>				<150	$\mu\text{V}_{RMS}$

- (1) 0 V may not lie within the range of measured values due to offset voltage limit and device calibration.
- (2) See text for specific conversion formula.
- (3) ADC is factory trimmed at the conversion speed of ~6  $\mu\text{s}$ /channel ( $FUNC\_CONFIG[ADCT1:0] = 01b$ ). Use of a different conversion-speed setting may affect measurement accuracy.
- (4) Specified by design, not measured in production

## TSn Measurement

Typical values stated where  $T_A = 25^\circ\text{C}$  and  $BAT = 20\text{V}$ , Min/Max values stated where  $T_A = -40^\circ\text{C}$  to  $85^\circ\text{C}$  and  $BAT = 7.2\text{V}$  to  $27\text{V}$  (unless otherwise noted),  $FUNCTION\_CONFIG[] = 01xxxx00b$  for all Test Conditions

PARAMETER		TEST CONDITION	MIN	TYP	MAX	UNIT
$V_{IN}$	Input voltage range, <sup>(1)</sup> $TSn+$ $TSn-$		0		2.5	V
$V_{RES}$	Voltage resolution, <sup>(2)</sup>	14 bits, $REG50 = 5\text{V}$ , (Resolution $\approx V_{REG50}/2^{15}$ )		~153		$\mu\text{V}$
$V_{ACC}$	Ratio accuracy, % of input <sup>(2)</sup>	$0.25\text{V} \leq V_{IN} \leq 2.5\text{V}$	-0.25%	$\pm 0.1\%$	0.25%	
$C_{IN}$	Input capacitance <sup>(3)</sup>	Converting		40		pF
$R_{IN}$	Effective input resistance <sup>(3)</sup>	Converting		50		k $\Omega$
$E_N$	Noise <sup>(3)</sup>				<150	$\mu\text{V}_{RMS}$

(1) 0 V may not lie within the range of measured values due to offset voltage limit and device calibration.

(2) See text for specific conversion formula.

(3) Specified by design, not measured in production

## THERMAL SHUTDOWN

PARAMETER		TEST CONDITIONS	MIN	TYP	MAX	UNIT
$T_{SD}$	Shutdown threshold <sup>(1)</sup>	$BAT = 20\text{V}$	125	142	156	$^\circ\text{C}$
$T_{HYS}$	Recovery hysteresis <sup>(1)</sup>			8	25	$^\circ\text{C}$

(1) Specified by design, not measured in production.

## UNDERVOLTAGE LOCKOUT (UVLO) and POWER-ON RESET (POR)

Typical values stated where  $T_A = 25^\circ\text{C}$  and  $BAT = 20\text{V}$ , Min/Max values stated where  $T_A = -40^\circ\text{C}$  to  $85^\circ\text{C}$  and  $BAT = 7.2\text{V}$  to  $27\text{V}$  (unless otherwise noted)

PARAMETER		TEST CONDITION	MIN	NOM	MAX	UNIT
$V_{UVLO}$	Negative-going threshold		5		5.6	V
$V_{UVLO\_HSY}$	Hysteresis		250	375	500	mV
$UVLO_{DELAY}$	Delay to locked-out condition	$V \leq V_{UVLO\ MIN}$		15		$\mu\text{s}$
$V_{POR}$	Negative-going threshold		4		5	V
$V_{POR\_HSY}$	Hysteresis		250	500	750	mV
$POR_{DELAY}$	Delay to disabled condition	$V \leq V_{POR\ MIN}$		15		$\mu\text{s}$
$t_{RST}$	Reset delay time	$V \geq V_{POR} + V_{POR\_HSY}$	40	56	70	ms

## BATTERY PROTECTION THRESHOLDS

Typical values stated where  $T_A = 25^\circ\text{C}$  and  $BAT = 20\text{ V}$ , Min/Max values stated where  $T_A = -40^\circ\text{C}$  to  $85^\circ\text{C}$  and  $BAT = 7.2\text{ V}$  to  $27\text{ V}$  (unless otherwise noted)

PARAMETER		TEST CONDITION	MIN	NOM	MAX	UNIT
$V_{OVR}$	OV detection threshold range <sup>(1)</sup>		2		5	V
$\Delta V_{OVS}$	OV detection threshold program step			50		mV
$V_{OVH}$	OV detection hysteresis			50		mV
$V_{OVA1}$	OV detection threshold accuracy	$3.3 \leq V_{OV\_SET} \leq 4.5$	-50	0	50	mV
$V_{OVA2}$	OV detection threshold accuracy	$V_{OV\_SET} < 3.3$ or $V_{OV\_SET} > 4.5$	-70	0	70	mV
$V_{UVR}$	UV detection threshold range <sup>(1)</sup>		700		3300	mV
$\Delta V_{UVS}$	UV detection threshold program step			100		mV
$V_{UVH}$	UV detection hysteresis			100		mV
$V_{UVA}$	UV detection threshold accuracy		-100	0	100	mV
$V_{OTR}$	OT detection threshold range <sup>(2)</sup>	$V_{REG50} = 5\text{ V}$	1		2	V
$\Delta V_{OTS}$	OT detection threshold program step <sup>(2)</sup>			See <sup>(3)</sup>		V
$V_{OTA}$	OT detection threshold accuracy <sup>(2)</sup>	$T = 40^\circ\text{C}$ to $90^\circ\text{C}$		0.04	0.05	V
$\Delta V_{OTH}$	OT reset hysteresis	$T = 40^\circ\text{C}$ to $90^\circ\text{C}$	8%	12%	15%	

(1) COV and CUV thresholds must be set such that  $COV - CUV \geq 300\text{ mV}$

(2) Using recommended components. Consult Table 2 in text for voltage levels used.

(3) See Table 2 for trip points.

## BATTERY PROTECTION DELAY TIMES

Typical values stated where  $T_A = 25^\circ\text{C}$  and  $BAT = 20\text{ V}$ , Min/Max values stated where  $T_A = -40^\circ\text{C}$  to  $85^\circ\text{C}$  and  $BAT = 7.2\text{ V}$  to  $27\text{ V}$  (unless otherwise noted)

PARAMETER		TEST CONDITION	MIN	NOM	MAX	UNIT
$t_{OV}$	OV detection delay-time range		0		3200	ms
$\Delta t_{OV}$	OV detection delay-time step	COVT [ $\mu\text{s}/\text{ms}$ ] = 0		100		$\mu\text{s}$
		COVT [ $\mu\text{s}/\text{ms}$ ] = 1		100		ms
$t_{UV}$	UV detection delay-time range		0		3200	ms
$\Delta t_{UV}$	UV detection delay-time step	CUVT[7] ( $\mu\text{s}/\text{ms}$ ) = 0		100		$\mu\text{s}$
		CUVT[7] ( $\mu\text{s}/\text{ms}$ ) = 1		100		ms
$t_{OT}$	OT detection delay-time range		0		2550	ms
$\Delta t_{OT}$	OT detection delay-time step			10		ms
$t_{acr}$	OV, UV, and OT detection delay-time accuracy <sup>(1)</sup>	CUVT, (COVT) $\geq 500\mu\text{s}$	-12%	0%	10%	
$t_{(DETECT)}$	Protection comparator detection time	$V_{OT}$ or $V_{OV}$ or $V_{UV}$ threshold exceeded by 10 mV			100	$\mu\text{s}$

(1) Under double or multiple fault conditions (of a single type), the second or greater fault may have its delay time shortened by up to the step time for the fault. I.e. the second and subsequent COV faults occurring within the delay time period for the first fault may have their delay time shortened by up to 100  $\mu\text{s}$ .

## OTP EPROM PROGRAMMING CHARACTERISTICS

Typical values stated where  $T_A = 25^\circ\text{C}$  and  $BAT = 20\text{ V}$ , Min/Max values stated where  $T_A = -40^\circ\text{C}$  to  $85^\circ\text{C}$  and  $BAT = 7.2\text{ V}$  to  $27\text{ V}$  (unless otherwise noted)

PARAMETER		TEST CONDITION	MIN	NOM	MAX	UNIT
$V_{PROG}$	Programming voltage		6.3	7	7.7	V
$t_{PROG}$	Programming time	$V_{BAT} \geq 20\text{ V}$	1500 <sup>(1)</sup>		2200	$\mu\text{s}$
$I_{PROG}$	Programming current			10	20	mA

(1) The write pulse is self-timed internally.  $V_{PROG}$  should be applied for this time at a minimum.

## AC TIMING CHARACTERISTICS

### SPI DATA INTERFACE

Typical values stated where  $T_A = 25^\circ\text{C}$  and  $BAT = 20\text{ V}$ , Min/Max values stated where  $T_A = -40^\circ\text{C}$  to  $85^\circ\text{C}$  and  $BAT = 7.2\text{ V}$  to  $27\text{ V}$  (unless otherwise noted)

PARAMETER		TEST CONDITION	MIN	TYP	MAX	UNIT
$f_{\text{SCLK}}$	SCLK frequency <sup>(1)</sup>		10	250	1000	kHz
$\text{SCLK}_{\text{DC}}$	SCLK_H duty cycle, $t_{\text{(HIGH)}} / t_{\text{(SCLK)}}$ or $t_{\text{(LOW)}} / t_{\text{(SCLK)}}$		40%		60%	
$t_{\text{CS,LEAD}}$	CS_H lead time, CS_N low to clock			50		ns
$t_{\text{CS,LAG}}$	CS_H lag time. Last clock to CS_N high		10			ns
$t_{\text{CS,DLY}}$	CS_H high to CS_H low (inter-packet delay requirement)		3			$\mu\text{s}$
$t_{\text{ACC}}$	CS_H access time <sup>(2)</sup> : CS_H low to SDO_H data out			125	250	ns
$t_{\text{DIS}}$	CS_H disable time <sup>(2)</sup> : CS_H high to SDO_H high impedance			2.5	2.7	$\mu\text{s}$
$t_{\text{SU,SDI}}$	SDI_H input-data setup time		15			ns
$t_{\text{HD,SDI}}$	SDI_H input-data hold time		10			ns
$t_{\text{VALID,SDO}}$	SDO_H output-data valid time SCLK_H edge to SDO_H valid	$C_L \leq 20\text{ pF}$		75	110	ns

- (1) Maximum SCLK frequency is limited by the number of bq76PL536 devices in the vertical stack. The maximum listed here may not be realizable in systems due to delays and limits imposed by other components including wiring, connectors, PCB material and routing, etc. See text for details.
- (2) Time listed is for single device.

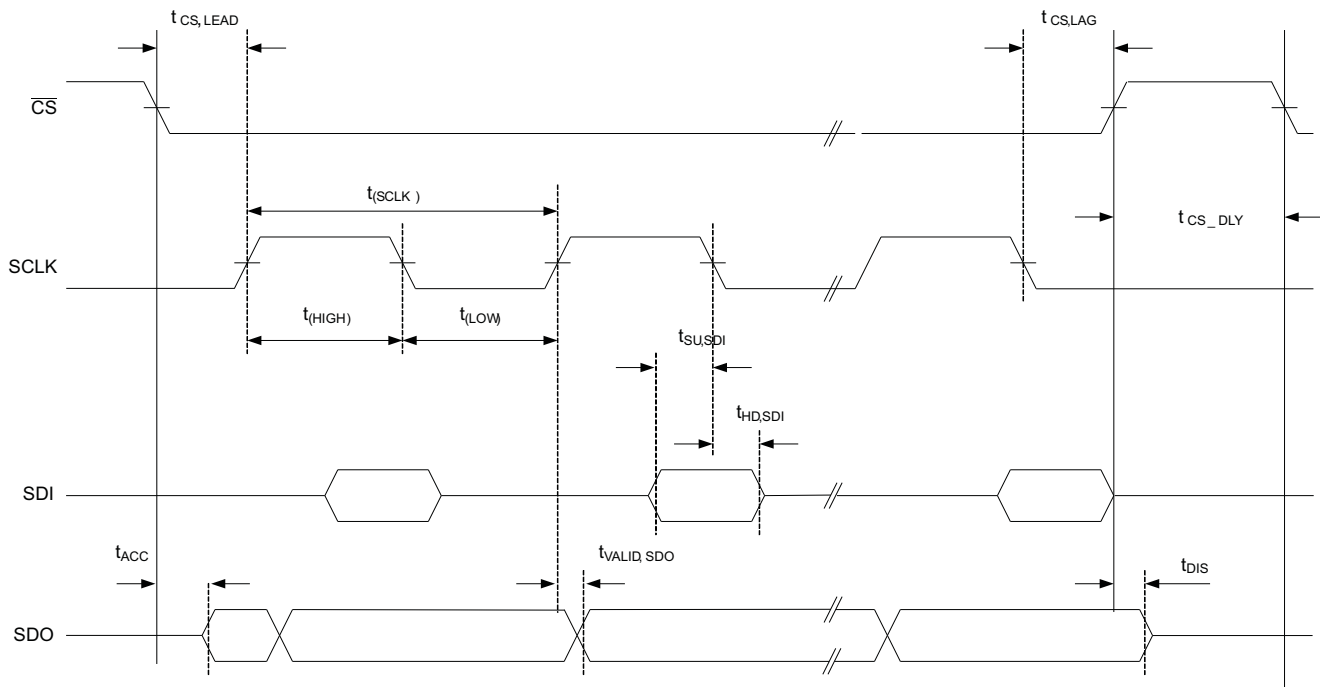

**Figure 3. SPI Host Interface Timing**

### Vertical Communications Bus

Typical values stated where  $T_A = 25^\circ\text{C}$  and  $BAT = 20\text{ V}$ , Min/Max values stated where  $T_A = -40^\circ\text{C}$  to  $85^\circ\text{C}$  and  $BAT = 7.2\text{ V}$  to  $27\text{ V}$

PARAMETER	TEST CONDITIONS	MIN	TYP	MAX	UNIT
$t_{\text{H,DELAY}}$	SCLK_H to SCLK_N, CS_H to CS_N, SDI_H to SDI_N, SDO_N to SDO_H delay times			5	ns

## Vertical Communications Bus (continued)

Typical values stated where  $T_A = 25^\circ\text{C}$  and  $BAT = 20\text{ V}$ , Min/Max values stated where  $T_A = -40^\circ\text{C}$  to  $85^\circ\text{C}$  and  $BAT = 7.2\text{ V}$  to  $27\text{ V}$

	PARAMETER	TEST CONDITIONS	MIN	TYP	MAX	UNIT
$t_{LS\_DELAY}$	SCLK_S to SCLK_N, CS_S to CS_N, SDI_S to SDI_N, SDO_N to SDO_S delay time				30	ns

## ANALOG-TO-DIGITAL CONVERSION (ADC)

### General Features

The integrated 14-bit (unsigned) high-speed successive approximation register (SAR) analog-to-digital converter uses an integrated band-gap reference voltage (VREF) for the cell and brick measurements. The ADC has a front-end multiplexer for nine inputs – six cells, two temperature sensors, and one general-purpose analog input (GPAl). The GPAl input can further be multiplexed to measure the *brick* voltage between the BATx pin and VC0 or the voltage between the GPAl+ and GPAl– pins.

The ADC and reference are factory trimmed to compensate for gain, offset, and temperature-induced errors for all inputs. The measurement result is not allowed to roll over due to offset error at the top and bottom of the range, i.e., a reading near zero does not underflow to 0x03ff due to offset error, and vice-versa.

The converter returns 14 valid unsigned magnitude bits in the following format:

<00xxxxxx xxxxxxxx>

Each word is returned in big-endian format in a register pair consisting of two adjacent 8-bit registers. The MSB of the word is located in the lower-address register of the pair, i.e., data for cell 1 is returned in registers 0x03 and 0x04 as 00xxxxxx xxxxxxxxb.

*Designer Note: The signal used to drive the ADC inputs sees about 45 pF of input capacitance when the mux switches the input to the ADC. The signal source should be capable of driving this capacitance without introducing error. The sampling time of the ADC is approximately 1  $\mu\text{s}$  when the default 3- $\mu\text{s}$  conversion time is selected. Therefore, the signal source must be capable of charging the 45-pF capacitance in approximately 200 nS to allow 5 t for settling; otherwise, the obtained reading will be in error.*

*Designer Note: The accuracy of the part may be affected by soldering, and may depend on the soldering process used. This has been typically measured at less than  $\pm 2\text{ mV}$  (IC typically reads higher than actual) at 3.6 V/cell input. The offset is fixed, and permanent after soldering. The effect is introduced in the ADC after the multiplexer, and therefore affects all inputs in the same way. The effect is per input, and not cumulative for all inputs. This error is in addition to the accuracy specification in the data sheet.*

### 3 to 6 Series Cell Configuration

When fewer than 6 cells are used, the most-positive cell voltage of the series string should be connected to the BAT1/BAT2 pins, through the RC input network shown in the *Reference Schematic* section. Unused VCx inputs should be connected to the next VCx input down until an input connected to a cell is reached – i.e., in a four cell stack, VC6 connects to VC5, which connects to VC4.

The internal multiplexer control can be set to scan only inputs which are connected to cells, thereby speeding up conversions slightly. The multiplexer is controlled by the ADC\_CONTROL[CN2:0] bits.

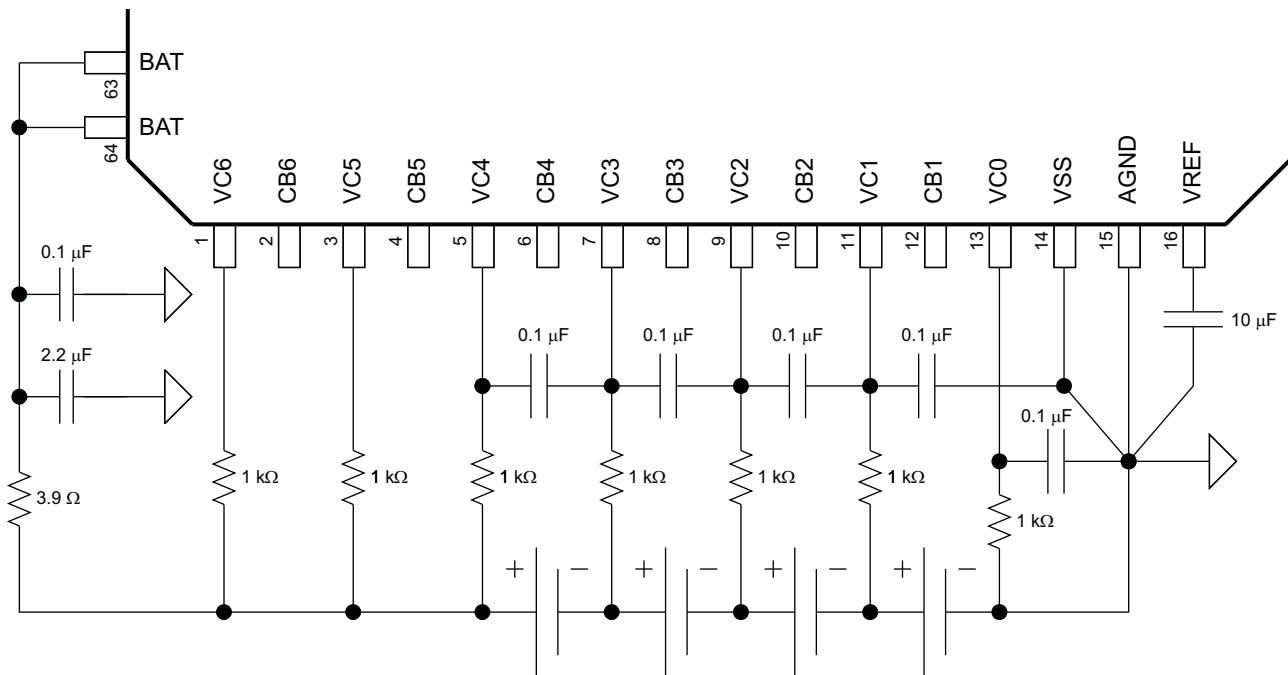

**Figure 4. Connecting < 6 Cells (4 Shown)**

### Cell Voltage Measurements

Converting the returned cell measurement value to a dc voltage (in mV) is done using the following formula (all values are in decimal).

$$\text{mV} = (\text{REG}_{\text{MSB}} \times 256 + \text{REG}_{\text{LSB}}) \times 6250 / 16383$$

Example:

Cell\_1 == 3.35 V (3350 mV);  
 After conversion, REG\_03 == 0x22; REG\_04 == 0x4d  
 $0x22 \times 0x100 + 0x4d = 0x224d$  (8781)  
 $8781 \times 6250 / 16,383 = 3349.89 \text{ mV} \approx 3.35 \text{ V}$

### GPAI or $V_{\text{BAT}}$ Measurements

The bq76PL536 features a differential input to the ADC from two external pins, GPAI+ and GPAI-. The ADC GPAI result register can be configured (via the FUNCTION\_CONFIG[GPAI\_SRC]) to provide a measurement of the voltage on these two pins, or of the *brick* voltage present between the BATx pins and VC0.

In the bq76PL536 device, the  $V_{\text{BAT}}$  measurement is taken from the BATx pin to the VC0 pin, and is a separate input to the ADC mux. Because this is a separate input to the ADC, certain common system faults, such as a broken cell wire, can be easily detected using the bq76PL536 and simple firmware techniques.

The GPAI measurement can be configured to use one of two references via FUNCTION\_CONFIG[GPAI\_REF]. Either the internal bandgap ( $V_{\text{REF}}$ ) or REG50 can be selected. When REG50 is selected, the ADC returns a ratio of the voltage at the inputs and REG50, removing the need for compensation of the REG50 voltage when used as a source to excite the sensor. When the device is configured to measure  $V_{\text{BAT}}$  (FUNCTION\_CONFIG[GPAI\_SRC] = 1), the device selects VREF automatically and ignores the FUNCTION\_CONFIG[GPAI\_REF] setting.

### Converting GPAI Result to Voltage

To convert the returned GPAI measurement value to a voltage using the internal band-gap reference (FUNCTION\_CONFIG[GPAI\_REF] = 1), the following formula is used.

$$\text{mV} = (\text{REG}_{\text{MSB}} \times 256 + \text{REG}_{\text{LSB}}) \times 2500 / 16,383$$

$$\text{FUNCTION\_CONFIG[]} = 0100 \text{ xxxxb}$$

Example:

The voltage connected to the GPAI inputs == 1.25 V;  
 After conversion, REG\_01 == 0x20; REG\_02 == 0x00  
 $0x20 \times 0x100 + 0x00 = 0x2000$  (8192)  
 $8192 \times 2500 / 16,383 = 1250$  mV

### Converting VBAT Result to Voltage

To convert the returned  $V_{\text{BAT}}$  measurement value to a voltage, the following formula is used.

$$V = (\text{REG}_{\text{MSB}} \times 256 + \text{REG}_{\text{LSB}}) \times 33.333 / 2^{14} \quad (33.333 \approx 6.25 / 0.1875)$$

$$\text{FUNCTION\_CONFIG[]} = 0101 \text{ xxxxb}$$

Example:

The sum of the series cells connected to VC6–VC0 == 20.295 V;  
 After conversion, REG\_01 == 0x26; REG\_02 == 0xf7  
 $0x26 \times 0x100 + 0xf7 = 0x26f7$  (9975)  
 $9975 \times 33.333 / 16,383 = 20.295$  V

### Temperature Measurement

The bq76PL536 can measure the voltage TS1+, TS1– and TS2+, TS2– differential inputs using the ADC. These inputs are typically driven by an external thermistor/resistor divider network. The TSn inputs use the REG50 output divided down and internally connected as the ADC reference during conversions. This produces a ratiometric result and eliminates the need for compensation or correction of the REG50 voltage drift when used to drive the temperature sensors. The REG50 reference allows an approximate 2.5-V full-scale input at the TSn inputs. The final reading is limited between 0 and 16,383, corresponding to an external ratio of 0 to 0.5.

Two control bits are required for the ADC to convert the TSn input voltages successfully. ADC\_CONTROL[TSn] is set to cause the ADC to convert the TSn channel on the next requested conversion cycle. IO\_CONTROL[TSn] is set to cause the FET switch connecting the TSn– input to VSS to close, completing the circuit of the voltage divider. The IO\_CONTROL[] bits should only be set as needed to conserve power; at high temperatures, thermistor excitation current may be relatively high.

### External Temperature Sensor Support (TS1+, TS1– and TS2+, TS2–)

The device is intended for use with a nominal 10 k $\Omega$  at 25°C NTC external thermistor (AT103 equivalent) such as the Panasonic ERT-J1VG103FA, a 1% device. A suitable external resistor-capacitor network should be connected to position the response of the thermistor within the range of interest. This is typically  $R_T = 1.47$  k $\Omega$  and  $R_B = 1.82$  k $\Omega$  (1%) as shown in [Figure 5](#). A parallel bypass capacitor in the range 1nF to 47nF placed across the thermistor should be added to reduce noise coupled into the measurement system. The response time delay created by this network should be considered when enabling the respective TS input prior to conversion and setting the OT delay timer. See [Figure 5](#) for details.

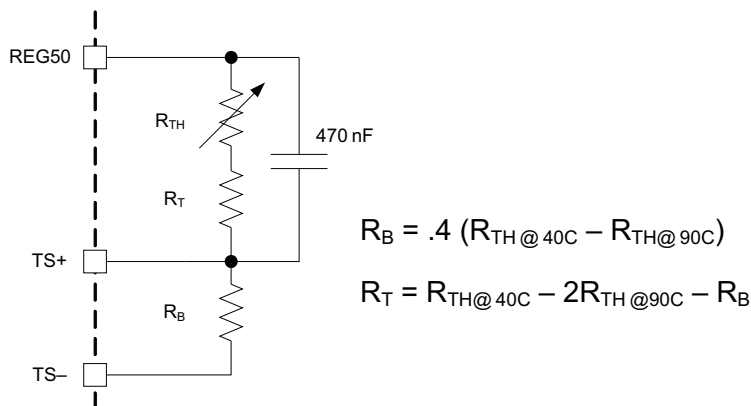
**Figure 5. Thermistor Connection**

### Converting TS<sub>n</sub> Result to Voltage (Ratio)

To convert the returned TS<sub>n</sub> measurement value to a ratio,  $R_{TS} = V_{TS} : \text{REG50}$ , the following formula is used.

ADC behavior:  $\text{COUNT} = V_{TS} / \text{REG50} \times 33,104$

$R_{TS} = (\text{REG}_{\text{MSB}} \times 256 + \text{REG}_{\text{LSB}}) / 16,548$

$\text{FUNCTION\_CONFIG}[] = 0100 \text{ xxxxb}$

Example:

The voltage connected to the TS<sub>n</sub> inputs (TS<sub>n+</sub> – TS<sub>n-</sub>) == 0.6609 V;  $V_{\text{REG50}} \approx 5 \text{ V}$  nominal

After conversion,  $\text{REG}_{\text{MSB}} == 0x11$ ;  $\text{REG}_{\text{LSB}} == 0x18$

$\text{ACTUAL\_COUNT} = 0x11 \times 0x100 + 0x18 = 0x1118$  (4376)

$4376 / 33,104 = 0.1322$  (ratio of TS<sub>n</sub> inputs to REG50)

$0.1322 \times \text{REG50} = 0.6609 \text{ V}$

### ADC Band-Gap Voltage Reference

The ADC and protection subsystems use separate and independent internal voltage references. The ADC bandgap ( $V_{\text{REF}}$ ) is nominally 2.5 V. The reference is temperature-compensated and stable.

The internal reference is brought out to the VREF pin for bypassing. A high quality 10- $\mu\text{F}$  capacitor should be connected between the VREF and AGND pins, in close physical proximity to the device pins, using short track lengths to minimize the effects of track inductance on signal quality. AGND should be connected to VSS. Device VSS connections should be brought to a single point close to the IC to minimize layout-induced errors. The device tab should also be connected to this point, and is a convenient common VSS location. The internal VREF should not be used externally to the device by user circuits.

### Conversion Control

#### Convert Start

Two methods are available to start a conversion cycle. The CONV\_H pin may be asserted, or firmware may set the CONVERT\_CTRL[CONV] bit.

#### Hardware Start

A single interface pin (CONV\_H) is used for conversion-start control by the host. A conversion cycle is started by a hardware signal when the CONV\_H is transitioned low-to-high by the host. The host should hold this state until the conversion cycle is complete to avoid erroneous edges causing a conversion start when the present conversion is not complete. The signal is simultaneously sent to the higher device in the stack by the assertion of the CONV\_N signal. The bq76PL536 automatically sequences through the series of measurements enabled via the ADC\_CONTROL[] register after a convert-start signal is received from either the register bit or the hardware pin.



If the CONV\_H pin is used in the design, it must be maintained in a default low state (~0 V) to allow use of the ADC\_CONVERT[CONV] bit to trigger ADC conversions. If the CONV pin is kept high, the ADC\_CONVERT[CONV] bit does not function, and device current consumption is increased by the signaling current, ~900  $\mu$ A. If the CONV\_H pin is not used by the user's design, the pin may be left floating; the internal current sink to VSS maintains proper bias.

### Firmware Start

The CONVERT\_CTRL[CONV] bit is also used to initiate a conversion by writing a 1 to the bit. It is automatically reset at the end of a conversion cycle. The bit may only be written to 1; the IC always resets it to 0. The BROADCAST form of packet is recommended to start all device conversions simultaneously.

*Designer Note: The external CONV\_H (CONV\_S) pin must be held in the de-asserted (=0) state to allow the CONV register bit to initiate conversions. An internal pulldown is provided on the pin to maintain this state.*

### Data Ready

The bq76PL536 signals that data is ready when the last conversion data has been stored to the associated data result register by asserting the DRDY\_S pin (DRDY\_H if HOST=0) if the DRDY\_N pin is also asserted. DRDY\_S (DRDY\_H) signals are cleared on the next rising edge of CONV\_H.

The DEVICE\_STATUS[DRDY] bit indicates the state of the DRDY\_N pin.

*Designer Note: The DRDY\_S pins remain asserted during SLEEP, leading to extra current consumption. As a workaround, user designs should read the last result of a conversion before placing the device in SLEEP.*

### ADC Channel Selection

The ADC\_CONTROL register can be configured as follows:

MEASUREMENT	ADC_CONTROL
VCELL1	CELL_SEL = 0x00
VCELL1, VCELL2	CELL_SEL = 0x01
VCELL1, VCELL2, VCELL3	CELL_SEL = 0x02
VCELL1, VCELL2, VCELL3, VCELL4	CELL_SEL = 0x03
VCELL1, VCELL2, VCELL3, VCELL4, VCELL5	CELL_SEL = 0x04
VCELL1, VCELL2, VCELL3, VCELL4, VCELL5, VCELL6	CELL_SEL = 0x05
External thermistor input 1	TS1 = 1
External thermistor input 2	TS2 = 1
General-purpose analog input	GPAI = 1

### Conversion Time Control

The ADC can be configured to adjust the conversion time to meet system requirements. The default conversion time is approximately 3  $\mu$ s (with ADC pre-configured to be ON by setting the ADC\_CONTROL[ADC\_ON] bit). This can be adjusted to approximately 3, 6, 12, or 24  $\mu$ s/channel by changing the value in the FUNCTION\_CONFIG[] register. The 6- $\mu$ s setting (FUNCTION\_CONFIG[ADCT1:0] = 01b) is recommended for best results over temperature.

### Automatic vs Manual Control

The ADC\_CONTROL[ADC\_ON] bit controls powering up the ADC section and the main bandgap reference. If the bit is set to 1, the internal circuits are powered on, and current consumption by the part increases. Conversions begin immediately on command. The host CPU should wait >500  $\mu$ s before initiating the first conversion after setting this bit.

If the ADC\_ON bit is false, an additional 500  $\mu$ s is required to stabilize the reference before conversions begin. In the AUTOMATIC mode, power consumption is greatly reduced. This is the recommended operating mode for the part.

## ADC Application Notes

### Anti-Aliasing Filter

An anti-aliasing filter, consisting of a 1-kΩ 1% series resistor and 100-nF capacitor, is required for each V<sub>Cn</sub> input. Good-quality components should be used. A 1% resistor is recommended, because the resistor creates a small error by forming a voltage divider with the input impedance of the part. The part is factory-trimmed to compensate for the error introduced by the filter.

### Using the 6-μs Conversion Setting

1. The conversion time is adjusted from 3 μs/channel to 6 μs/channel. This extends the total time to convert all cell voltages from ≈21 μs (6 × 3 μs + 3 μs) to ≈ 42 μs (6 × 6 μs + 6 μs). To convert all cell voltages, plus the *brick* voltage, plus the two temperature inputs requires ≈ 60 μs (9 × 6 μs + 6 μs).
2. The ADC\_CTRL[ADC\_ON] bit is set to 1 for conversions. The ADC\_CTRL[] register is located at address 0x30.

The conversion time is controlled by the FUNCTION\_CONFIG[] register at address 0x40. Two bits, ADCT0, ADCT1 set the time per [Table 1](#).

FUNCTION_CONFIG REGISTER (0x40)							
7	6	5	4	3	2	1	0
ADCT[1]	ADCT[0]	GPAI_REF	GPAI_SRC	CN[1]	CN[0]	-	-

The FUNCTION\_CONFIG sets the default configuration for special features of the device.

[7..6] (ADCT[0,1]): These bits set the conversion timing of the ADC measurement.

**Table 1.**

ADCT[1]	ADCT[0]	~Conversion Time (μs)
0	0	3
0	1	6
1	0	12
1	1	24

A design issue in the device requires that any time the ADCT[1:0] bits are not equal to 0, the ADC\_ON bit must be set to 1 before initiating a conversion cycle. TI recommends setting the bit to 1 during battery operations when conversions are to be made (it may be left on). The bit can be turned off when conversions are not active, i.e., during the *key-off* time. When the bit is turned on, the hardware enforces a 500-μs ±5% wait before conversions are permitted. User firmware should wait the minimum ≈500 μs before requesting a conversion start after ADC\_ON = 1.

#### NOTE

If a conversion cycle is inadvertently started while (ADCT[1:0] ≠ 0 <AND> ADC\_ON = 0), the device appears to lock up and stop working. To correct this behavior, send a device RESET command (write 0xa5 to register 0x3c) followed by any customer-specific register initialization. The RESET command also resets the device address to 0x00, making it necessary to reassign addresses to all devices in the stack.

The bit may be turned on and left on, or dynamically manipulated at each conversion depending on user firmware requirements.

TI recommends programming the OTP register to set the conversion rate permanently. This procedure is described in the data sheet for the device. A typical value for FUNCTION\_CONFIG[] register 0x40 is 0x50. See the [FUNCTION\\_CONFIG REGISTER \(0x40\)](#) section for further details of the other bit functions.

#### Procedure:

##### **OTP EPROM is Pre-programmed to 6 μs (0x40 = 0101 xx00b):**

1. Prior to any conversion:

Write `ADC_CONFIG[ADC_ON] = 1` (`0x30 = 01xx xxxxb`)

Note: To convert all inputs typically, use `0x30 = 0111 1101b`

#### **9.8.2.1.2 Alternate Method - Use Shadow RAM Feature (EPROM 0x40 Programmed Value is Don't Care):**

The shadow RAM feature allows temporarily overwriting EPROM contents. At RESET, group-3 RAM registers are loaded from OTP EPROM. The device always uses the contents of the RAM register internally to control the device. The RAM register may be subsequently overwritten with a new value to modify the device defaults programmed in EPROM. The new value is valid until the next device RESET. This example assumes that all inputs are converted.

1. Setup for 6- $\mu$ s/ch conversion time:

Write `SHDW_CTRL[] = 0x35` (register `0x3a = 0x35`) to enable the write to `FUNCTION_CONFIG[]`.

Immediately followed by:

Write `FUNCTION_CONFIG[] = 0x50` (register `0x40 = 0x50`)

2. Prior to any conversion:

Write `ADC_CTRL[] = 0x7d` (register `0x30 = 0x7d`)

Wait >1 ms before converting after setting `ADC_ON = 1` in the previous step.

3. Converting:

Conversions are now initiated normally, using the `CONV_H` pin or the `CONVERT[CONV]` register bit.

Note: Power may be significantly reduced by setting the bit `ADC_ON = 0`.

## **Secondary Protection**

The bq76PL536 integrates dedicated overvoltage and undervoltage fault detection for each cell and two overtemperature fault detection inputs for each device. The protection circuits use a separate band-gap reference from the ADC system and operate independently. The protector also uses separate I/O pins from the main communications bus, and therefore is capable of signaling faults in hardware without intervention from the Host CPU.

### **Protector Functionality**

When a fault state is detected, the respective fault flag in the `FAULT_STATUS[]` or `ALERT_STATUS[]` registers is set. All flags in the `FAULT` and `ALERT` registers are then ORed into the `DEVICE_STATUS[]` `FAULT` and `ALERT` bits. The `FAULT` and `ALERT` bits in `DEVICE_STATUS[]` in turn cause the hardware `FAULT_S` or `ALERT_S` pin to be set. The bits in `DEVICE_STATUS[]` and the hardware pins are latched until reset by the host via SPI command, ensuring that the host CPU does not miss an event.

A separate timer is provided for each fault source (cell overvoltage, cell undervoltage, overtemperature) to prevent false alarms. Each timer is programmable from 100  $\mu$ s to more than 3 s. The timers may also be disabled, which causes fault conditions to be sensed immediately and not latched.

The clearing of the `FAULT` or `ALERT` flag (and pin) occurs when the respective flag is written to a 1, which also restarts the respective fault timer. This also clears the `FAULT_S (_H)` or `ALERT_S (_H)` pin. If the actual fault remains present, the `FAULT (ALERT)` pin is again asserted at the expiration of the timer. This cycle repeats until the cause of the fault is removed.

On exit from the `SLEEP` state, the `COV`, `CUV`, and `OT` fault comparators are disabled for approximately 200  $\mu$ s to allow internal circuitry to stabilize and prevent false error condition detection.

### **Using the Protector Functions With 3-5 Cells**

The `OV/UV` condition can be ignored for unused channels by setting the `FUNCTION_CONFIG[CNx]` bits to the maximum number of cells connected to the device. If fewer than 6 cells are configured, the corresponding `OV/UV` faults are ignored. For example, if the `FUNCTION_CONFIG[]` bits are set to `xxxx 1000`, then the `OV/UV` comparators are disabled for cells 5 and 6. Correct setting of this register prevents spurious false alarms.

## Cell Overvoltage Fault Detection (COV)

When the voltage across a cell exceeds the programmed COV threshold for a period of time greater than set in the COV timer (COVT), the COV\_FAULT[] flag for that cell is set. The bits in COV\_FAULT[] are then ORed into the FAULT[COV] flag, which is then ORed into the DEVICE\_STATUS[FAULT] flag, which causes the FAULT\_S (\_H) pin also to be asserted. The COV flag is latched unless COVT is programmed to 0, in which case the flag follows the fault condition. Care should be taken when using this setting to avoid *chatter* of the fault status. To reset the FAULT flag, first remove the source of the fault (i.e., the overvoltage condition) and then write a 1 to FAULT[COV], followed by a 0 to FAULT[COV].

The voltage trip point is set in the CONFIG\_COV register. Set points are spaced every 50 mV. Hysteresis is provided to avoid chatter of the fault sensing. The filter delay time is set in the CONFIG\_COVT[] register to prevent false alarms. A start-up deglitch circuit is applied to the timers to prevent false triggering. The deglitch time is 0–50  $\mu$ s, and introduces a small error in the timing for short times. For both CUVT, and CUVT, this can cause an error greater than the 10% maximum specified for delays <500  $\mu$ s.

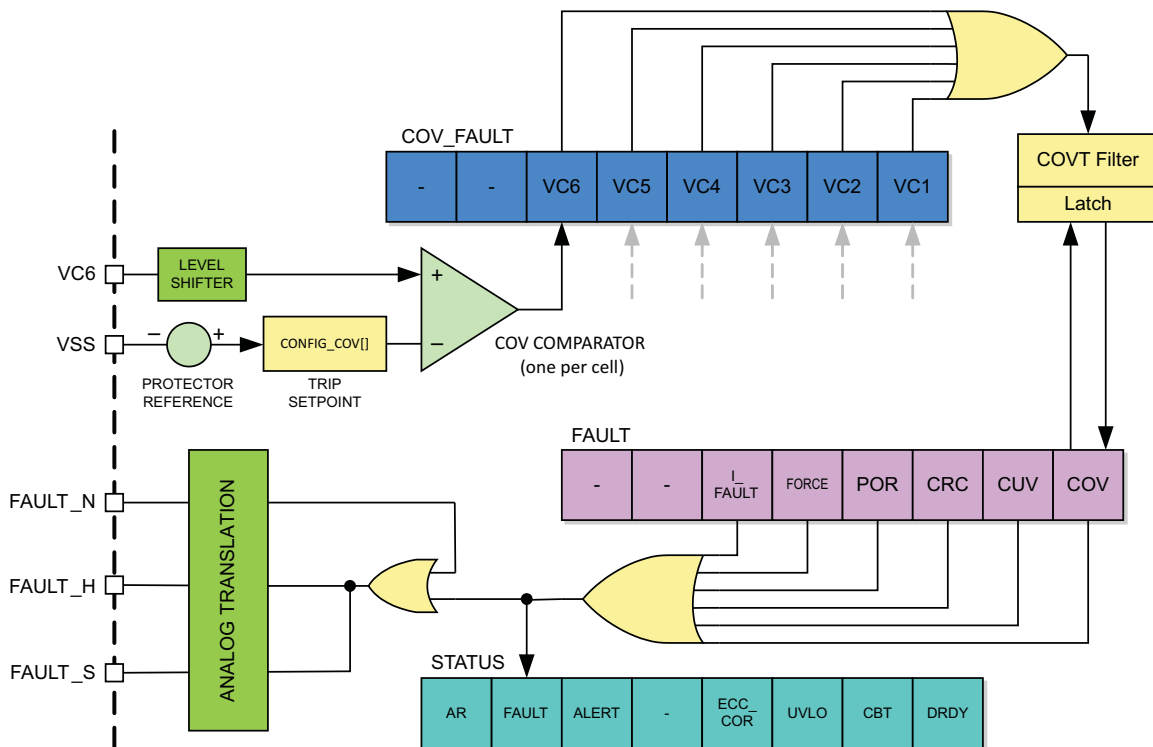

**Figure 6. COV FAULT Simplified Logic Tree**

## Cell Undervoltage Fault Detection (CUV)

Cell undervoltage detection operates in a similar manner to the COV protection. When the voltage across a cell falls below the programmed CUV threshold (CONFIG\_CUV[]) for a period of time greater than CUVT (CONFIG\_CUVT[]), the CUV\_FAULT[] flag for that cell is set. The bits in CUV\_FAULT[] are then ORed into the FAULT[CUV] flag, which is then ORed into the DEVICE\_STATUS[FAULT] flag, which causes the FAULT\_S (\_H) pin also to be asserted. The CUV flag is latched unless CUVT is programmed to 0, in which case the flag follows the fault condition. Care should be taken when using this setting to avoid *chatter* of the fault status. To reset the FAULT flag, first remove the source of the fault (i.e., the overvoltage condition) and then write a 1 to FAULT[CUV], followed by a 0 to FAULT[CUV].

## Overtemperature Detection

When the temperature input TS1 or TS2 exceeds the programmed OT1 or OT2 threshold (CONFIG\_OT[]) for a period of time greater than OTT (CONFIG\_OTT[]) the ALERT\_STATUS[OT1, OT2] flag is set. The ALERT[] flags are then ORed into the DEVICE\_STATUS[ALERT] flag, and the ALERT\_S (\_H) pin is also asserted. The OT flag is latched unless OTT is programmed to 0, in which case the flag follows the fault condition. Care should be taken when using this setting to avoid *chatter* of the fault status. To reset the FAULT flag, first remove the source of the alert (i.e., the overtemperature condition) and then write a 1 to ALERT[OTn], followed by a 0 to FAULT[OTn].

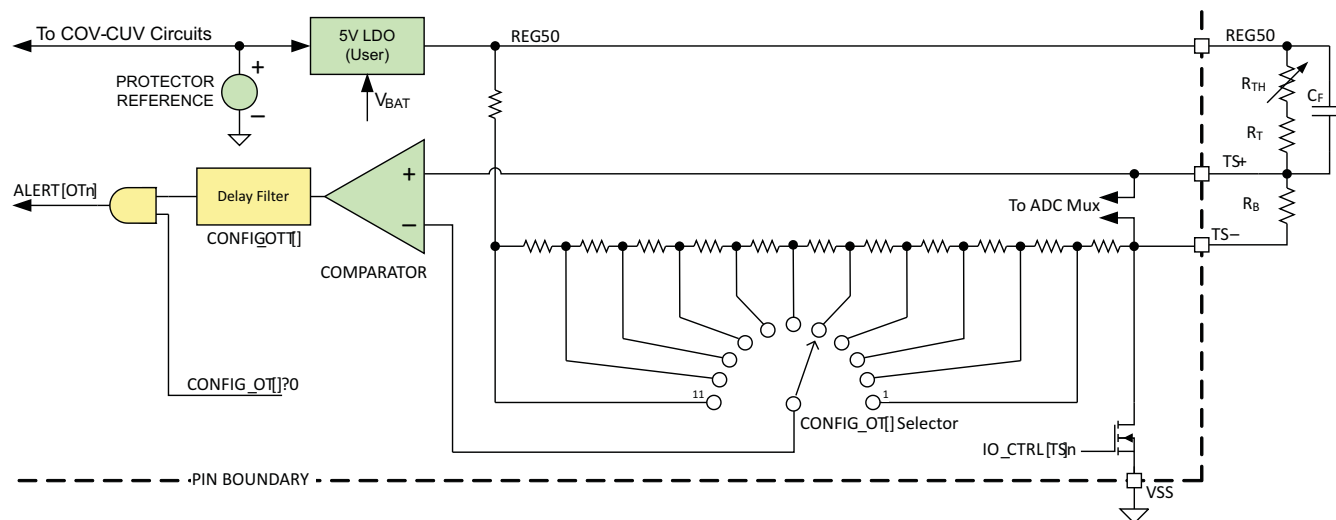

Figure 7. Simplified Overtemperature Detection Schematic

As shown in the drawing above, the OT thresholds are detectable in 11 steps representing approximately 5°C divisions when a thermistor and gain/offset setting registers are chosen using the formula in the [External Temperature Sensor Support \(TS1+, TS1– and TS2+, TS2–\)](#) section. A *DISABLED* setting is also available. This results in an adjustment range from approximately 40°C to 90°C, but the range center can be moved by modifying the R<sub>T</sub> value. The steps are spaced in a non-linear fashion to correspond to typical thermistor response curves. Typical accuracy of a few degrees C or better can be achieved (with no additional calibration requirements) by careful selection of the thermistor and resistors.

Each input sensor can be adjusted independently via separate registers CONFIG\_OT1[] and CONFIG\_OT2[]. The two temperature setpoints share a common filter delay set in the CONFIG\_OTT[] register. A setting of 0 in the CONFIG\_OTT[] register causes the fault sensing to be both instantaneous and not latched. All other settings provide a latched ALERT state.

## Ratiometric Sensing

The OT protector circuits use ratiometric inputs to sense fault conditions. The REG50 output is applied internally to the divider which forms the reference voltages used by the comparator circuit. It is also used externally as the excitation source for the temperature sensor. This allows the REG50 output to vary over time or temperature (within data-sheet limits) and have virtually no effect on the correct operation of the circuit. Any change seen by the sensor is also seen by the divider, and therefore, changes proportionally. Although it is valid to represent the trip setpoints as voltages if you assume that REG50 is at exactly 5 V, in practice, this is not the case. In the chart included in the next section, the correct ratios  $[R_B / (R_B + R_T + R_{TH})]$  are shown, along with the equivalent voltage points when REG50 is assumed to be 5 V.

Table 2. Overtemperature Trip Setpoints

OT THRESHOLDS					
CONFIG_OT	T <sub>NOM</sub> °C	V <sub>TS</sub> RATIO SET	V <sub>TS</sub> RATIO CLEAR	V <sub>SET</sub> <sup>(1)</sup>	V <sub>CLEAR</sub> <sup>(1)</sup>
0	Disabled	Disabled	Disabled	Disabled	Disabled

(1) Assumes REG50 = 5.000 V

**Table 2. Overtemperature Trip Setpoints (continued)**

OT THRESHOLDS					
CONFIG_OT	T <sub>NOM</sub> °C	V <sub>TS</sub> RATIO SET	V <sub>TS</sub> RATIO CLEAR	V <sub>SET</sub> <sup>(1)</sup>	V <sub>CLEAR</sub> <sup>(1)</sup>
1	40	0.2000	0.1766	1.000	0.883
2	45	0.2244	0.2000	1.122	1.000
3	50	0.2488	0.2270	1.244	1.135
4	55	0.2712	0.2498	1.356	1.249
5	60	0.2956	0.2750	1.478	1.375
6	65	0.3156	0.2956	1.578	1.478
7	70	0.3356	0.3162	1.678	1.581
8	75	0.3556	0.3368	1.778	1.684
9	80	0.3712	0.3528	1.856	1.764
10	85	0.3866	0.3688	1.933	1.844
11	90	0.4000	0.3824	2.000	1.912

### Thermistor Power

To minimize power consumption, the thermistors are not powered ON by default. Two bits are provided in IO\_CONTROL[] to control powering the thermistors, TS1 and TS2. The TS<sub>n</sub>– input is only connected to VSS when the corresponding bit is set. The user firmware must set these bits to 1 to enable both temperature measurement and the secondary protector functions. When the thermistor functions are not in use, the bits may be programmed to 0 to remove current through the thermistor circuits.

### Thermistor Input Conditioning

A filter capacitor is recommended to minimize noise in to the ADC and protector. The designer should insure that the filter capacitor has sufficient time to charge before reading the thermistors. The CONFIG\_OTT[] value should also be set to >5t, the time delay introduced by the RC network comprising C<sub>F</sub>, R<sub>TH</sub>, R<sub>T</sub>, and R<sub>B</sub>, to avoid false triggering of the PROTECTOR function and ALERT signal when the TS1 and/or TS2 bits are set to 1 and the inputs enabled.

On exit from the SLEEP state, the OT fault comparators are disabled for approximately 200 μs to allow internal circuitry to stabilize and prevent false error-condition detection.

### Fault and Alert Behavior

When the FAULT\_N pin is asserted by the next higher bq76PL536 in the stack, then the FAULT\_S is also asserted, thereby passing the signal down the array of stacked devices if they are present. FAULT\_N should always be connected to the FAULT\_S of the next higher device in the stack. If no higher device exists, it should be tied to VBAT of this bq76PL536, either directly or via a pullup resistor ~10 kΩ to 1 MΩ. The FAULT\_x pins are active-high – current flows when asserted. The ALERT\_x pins behave in a similar manner. If the FAULT\_N pin of the base device (HSEL = 0) becomes asserted, it asserts its FAULT\_H signal to the host microcontroller. This signal chain may be used to create an interrupt to the CPU, or drive other compatible logic or I/O directly.

**Table 3. Fault Detection Summary**

FAULT	DETECTION	SIGNALLING			
		PIN		DEVICE_STATUS BIT SET	X_STATUS BIT SET
		HSEL = 1	HSEL = 0		
EPROM double bit error	ECC logic fault detected	FAULT_S	FAULT_H	FAULT	FAULT_STATUS[I_FAULT]
FORCE	User set FORCE bit	FAULT_S	FAULT_H	FAULT	FAULT_STATUS[FORCE]
POR	Power-on reset occurred	FAULT_S	FAULT_H	FAULT	FAULT_STATUS[POR]
CRC	CRC fail on received packet	N/A	N/A	FAULT	FAULT_STATUS[CRC]
CUV	V <sub>Cx</sub> < V <sub>UV</sub> for t <sub>UV</sub>	FAULT_S	FAULT_H	FAULT	FAULT_STATUS[CUV]
COV	V <sub>Cx</sub> > V <sub>OV</sub> for t <sub>OV</sub>	FAULT_S	FAULT_H	FAULT	FAULT_STATUS[COV]
AR	Address ≠ (0x01 → 0x3e)	ALERT_S	ALERT_H	ALERT	ALERT_STATUS[AR]



**Table 3. Fault Detection Summary (continued)**

FAULT	DETECTION	SIGNALING			
		PIN		DEVICE_STATUS BIT SET	X_STATUS BIT SET
		HSEL = 1	HSEL = 0		
Protected-register parity error	Parity not even in protected register	ALERT_S	ALERT_H	ALERT	ALERT_STATUS[PARITY]
EPROM single-bit error	ECC logic fault detected and corrected	ALERT_S	ALERT_H	ALERT	ALERT_STATUS[ECC_COR]
FORCE	User set FORCE bit	ALERT_S	ALERT_H	ALERT	ALERT_STATUS[FORCE]
Thermal shutdown	Die temperature $\geq$ TSD <sub>THRESHOLD</sub>	ALERT_S	ALERT_H	ALERT	ALERT_STATUS[TSD]
SLEEP	IC exited SLEEP mode	ALERT_S	ALERT_H	ALERT	ALERT_STATUS[SLEEP]
OT2	$V_{TS2} > V_{OT}$ for $t_{OT}$	ALERT_S	ALERT_H	ALERT	ALERT_STATUS[OT2]
OT1	$V_{TS1} > V_{OT}$ for $t_{OT}$	ALERT_S	ALERT_H	ALERT	ALERT_STATUS[OT1]

### Fault Recovery Procedure

When any error flag in DEVICE\_STATUS[], FAULT\_STATUS[], or ALERT\_STATUS[] is set and latched, the state can only be cleared by host communication via SPI. Writing to the respective FAULT\_STATUS or ALERT\_STATUS register bit with a 1 clears the latch for that bit. The exceptions are the two FORCE bits, which are cleared by writing a 0 to the bit.

The FAULT\_STATUS[] and ALERT\_STATUS[] register bits are read-only, with the exception of the FORCE bit, which may be directly written to either a 1 or 0.

### Secondary Protector Built-In Self-Test Features

The secondary protector functions have built-in test for verifying the connections through the signal chain of ICs in the stack back to the host CPU. This verifies the wiring, connections, and signal path through the ICs by forcing a current through the signal path.

To implement this feature, host firmware should set the FAULT[FORCE] or ALERT[FORCE] bit in the top-most device in the stack. The device asserts the associated pin on the South interface, and it propagates down the stack, back to the base device. The base device in turn asserts the FAULT\_H (ALERT\_H) pin to the host, allowing the host to check for the received signal and thereby verify correct operation.

## CELL BALANCING

The bq76PL536 has six dedicated outputs (CB1...CB6) that can be used to control external N-FETs as part of a cell balancing system. The implementation of appropriate algorithms is controlled by the system host. The CB\_CTRL[CBAL1–6] bits control the state of each of the outputs. The outputs are copied from the bit state of the CB\_CTRL register, i.e., a 1 in this register activates the external balance FET by placing a high on the associated pin.

The CBx pins switch between approximately the positive and negative voltages of the cell across which the external FET is connected. This allows the use of small, low-cost N-FETs in series with a power resistor to provide cell balancing.

### Cell Balance Control Safety Timer

The CBx outputs are cleared when the internal safety timer expires. The internal safety timer (CB\_TIME) value is programmed in units of seconds or minutes (range set by CB\_CTRL bit 7) with an accuracy of  $\pm 10\%$ .

The timer begins when any CB\_CTRL bit changes from 0 to 1. The timer is reset if all CB\_CTRL bits are modified by the host from 1 to 0, or by expiration of the timing period. The timing begins counting the programmed period from start *each time* the CB\_CTRL[] register is programmed from a zero to a non-zero value in the lower six bits. In example, if the CB\_TIME[] is set for 30 s, then one or more bits are set in the CB\_CTRL[] register to balance the corresponding cells; then after 10 s the user firmware sets CB\_CTRL[] to 0x00, takes a measurement, then reprograms CB\_CTRL[] with the same or new bit pattern, the timer begins counting 30 s again before expiring and disabling balancing. This restart occurs each time the CB\_CTRL bits are set to a

## bq76PL536

SLUSA08A – DECEMBER 2009 – REVISED JULY 2010

www.ti.com

non-zero value. If this is done at a greater rate than the balancing period for which timer CB\_TIME[] is set, balancing is effectively never disabled – until the timer is either allowed to expire without changing the CB\_CTRL[] register to a non-zero value, or the CB\_CTRL[] register is set to zero by the user firmware. If the CB\_CTRL[] register is not manipulated from zero to non-zero while the timer is running, the timer expires as expected. Alterations of the value from a non-zero to a different non-zero value *do not* restart the timer (i.e., from 0x02 to 0x03, etc).

While the timer is running, the host may set or reset any bit in the CB\_CTRL[] register at any time, and the CBx output follows the bit.

The host may re-program the timer at any time. The timer must always be programmed to allow the CBx outputs to be asserted. While the timer is non-zero, the CB\_CTRL[] settings are reflected at the outputs.

During periods when the timer is actively running (not expired), then DEVICE\_STATUS[CBT] is set.

## OTHER FEATURES AND FUNCTIONS

### Internal Voltage Regulators

The bq76PL536 derives power from the BAT pin using several internal low dropout (LDO) voltage regulators. There are separate LDOs for internal analog circuits (4.5 V at LDOA), digital circuits (5 V at LDOD1 and LDOD2), and external, user circuits (5 V at REG50). The BAT pin should be connected to the most-positive cell input from cell 3, 4, 5, or 6, depending on the number of cells connected. A small series resistor and filter capacitors close to the IC are recommended. The internal LDOs and internal VREF should not be used to power external circuitry.

#### Internal 4.5-V Analog Supply

The internal analog supply should be bypassed at the LDOA pin with a good-quality, low-ESR, 2.2- $\mu$ F ceramic capacitor.

#### Internal 5-V Analog Supply

The internal digital supply should be bypassed at the LDOD1(2) pin with a good-quality, low-ESR, 2.2- $\mu$ F ceramic capacitor. The two pins are connected internally and provided to enhance single-pin failure-mode fault tolerance. They should also be connected together externally.

*Designer Note: Because the LDODx inputs are pulled briefly to ~7 V during programming, the LDODx pins should not be used as sources for pullups to 5-V digital pins, such as HSEL and SPI(bus)\_H connected pins. Use LDOA or VREG50 instead, unless all programming is completed prior to mounting on the application PCB, in which case LDODx is a good choice.*

#### Low-Dropout Regulator (REG50)

The bq76PL536 has a low-dropout (LDO) regulator provided to power the thermistors and other external circuitry. The input for this regulator is  $V_{BAT}$ . The output of REG50 is typically 5 V. A minimum 2.2- $\mu$ F capacitor is required for stable operation. The output is internally current-limited. The output is reduced to near zero if excess current is drawn, causing die temperatures to rise to unacceptable levels.

The 2.2- $\mu$ F output capacitor is required whether REG50 is used in the design or not.

REG50 is disabled in SLEEP mode, and may be turned off under thermal-shutdown conditions, and therefore should not be used as a pullup source for terminating device pins where required.

#### Auxiliary Power Output (AUX)

The bq76PL536 provides an approximately 1-mA auxiliary power output that is controlled via IO\_CONTROL[AUX]. This output is taken directly from REG50. The current drawn from this pin must be included in the REG50 current-limit budget by the designer.

#### Undervoltage Lockout and Power-On Reset

The device incorporates two comparators to detect low  $V_{BAT}$  conditions. The first detects low voltage where some device digital operations are still available. The second, (POR) detects a voltage below which device operation is **not** ensured.



## UVLO

When the UVLO threshold voltage is sensed for a period  $\geq$  UVLO<sub>DELAY</sub>, the device is no longer able to make accurate analog measurements and conversions. The ADC, cell-balancing and fault-detection circuitry are disabled. The digital circuitry, including host CPU and vertical communications between ICs, is fully functional. Register contents are preserved with the exception that CB\_CTRL is set to 0, and the UVLO bit is set in DEVICE\_STATUS[*UVLO*].

## Power-On Reset (POR)

When the POR voltage threshold or lower is sensed for a period  $\geq$  UVLO<sub>DELAY</sub>, the device is no longer able to function reliably. The device is disabled, including all fault-detection circuitry, host SPI communications, vertical communications, etc.

After the voltage rises above the hysteresis limit longer than the delay time, the device exits the reset state, with all registers set to default conditions. The FAULT\_STATUS[POR] bit is set and latched until reset by the host. The device no longer has a valid address (DEVICE\_ADDRESS[AR] = 0, ADDRESS\_CONTROL[*AR*] = 0). The device should be reprogrammed with a valid address, and any registers re-written if non-default values are desired.

## Reset Command

The bq76PL536 can also be reset by writing the reset code (0xa5) to the RESET register. All devices respond to a broadcast RESET command regardless of their current assigned address. The result is identical to a POR with the exception that the normal POR period is reduced to several hundred microseconds.

## Thermal Shutdown (TSD)

The bq76PL536 contains an integrated thermal shutdown circuit whose sensor is located near the REG50 LDO and has a threshold of TSD. When triggered, the REG50 regulator reduces its output voltage to zero, and the ADC is turned off to conserve power. The thermal shutdown circuit has a built-in hysteresis that delays recovery until the die has cooled slightly. When the thermal shutdown is active, the DEVICE\_STATUS[TSD] bit is set. The IO\_CONTROL[SLEEP] and ALERT[SLEEP] bits also become set to reduce power consumption.

### WARNING

**The secondary protector settings are DISABLED in the TSD state.**

### CAUTION

Temperature measurement and monitoring do not function due to loss of power if the thermistors are powered from the REG50 or AUX pins and TSD occurs. Protection-dependent schemes implemented by the designer which depend on the REG50 voltage also may not function as a result of loss of the REG50 output.

## GPIO

The bq76PL536 includes a general-purpose input/output pin controlled by the IO\_CONTROL[GPIO\_OUT] bit. The state of this bit is reflected on the pin. To use the pin as an input, program GPIO\_OUT to a 1, and then read the IO\_CONTROL[GPIO\_IN] bit. A pullup (10 k $\Omega$ –1 M $\Omega$ , typ.) is required on this pin if used as an input. *If the pullup is not included in the design, system firmware must program a 0 in IO\_CONTROL[GPIO\_OUT] to prevent excess current draw from the floating input. Use of a pullup is recommended in all designs to prevent an unintentional increase in current draw.*

## SLEEP Functionality

The bq76PL536 provides the host a mechanism to put the part into a low-power sleep state by setting the IO\_CONTROL[SLEEP] bit. When this bit is set/reset, the following actions occur:

### Sleep State Entry (bit set)

If a conversion is in progress, the device waits for it to complete, then sets DRDY true (high).

The device sets the ALERT\_STATUS[SLEEP] bit, which in turn causes the ALERT pin to be asserted.

The device gates off all other sources of FAULT or ALERT *except* ALERT[SLEEP]. The existing state of the FAULT and ALERT registers is preserved. The host should service and reset the ALERT generated by the SLEEP bit being set to minimize SLEEP state current draw by writing a 1 to ALERT[SLEEP] followed by a 0 to ALERT[SLEEP]. The ALERT North-South signal chain can draw up to ~1 mA of current when active, so this ALERT source should be cleared prior to the host entering the SLEEP state of its own. This signaling is provided to notify the host that the unmonitored/unprotected state is being entered.

The REG50 LDO is shut down and the output is allowed to float. The ADC, its reference, and clocks are disabled. The COV, CUV, and OT circuits are disabled, and their band-gap reference shut off. **Note that this effectively removes protection and monitoring from the cells; the designer should take the necessary design steps and verifications to ensure the cells cannot be put into an unsafe condition by other parts of the system or usage characteristics.**

IO\_CONTROL[TS1(2)] bits are not modified. The host must also set these bits to zero to minimize current draw of the thermistors themselves.

SPI communications are preserved; all registers may be read or written.

### Sleep State Exit (Bit Reset)

VREG50 operation is restored.

COV, CUV, OT circuits are re-enabled.

The ADC circuitry returns to its former state. Note that there is a warm-up delay associated with the ADC enable, the same delay as specified for enabling from a cold start.

The FAULT and ALERT registers are restored to their pre-SLEEP state. If a FAULT or ALERT condition was present prior to SLEEP, the FAULT or ALERT pin is immediately asserted.

IO\_CONTROL[TS1(2)] should be set by the host if the OT function or temperature measurement functions are desired.

## COMMUNICATIONS

### SPI Communications – Device to Host

Device-to-host (D2H) mode is provided on the SPI interface pins for connection to a local host microcontroller, logic, etc. D2H communications operate in voltage mode as a standard SPI interface for ease of connection to the outside world from the bq76PL536 device. Standard TTL-compatible logic levels are presented. All relevant SPI timing and performance parameters are met by this interface.

The host interface operates in SPI mode 1, where CPOL = 0 and CPHA = 1. The SPI clock is normally low; data changes on rising edges, and is sampled on the falling edge. All transfers are MSB-first.

The pins of the base IC (only) in a stack should have the SCLK\_H and SDI\_H pins terminated with pullups to minimize current draw of the part if the host ever enters a state where the pins are not driven. In non-base devices, the \_H pins are forced to be all outputs driven low when the HSEL pin is high. In non-base devices, all \_H pins should remain unconnected.

The CS\_H has a pullup resistor of approximately 100 k $\Omega$ . SDO\_H is a 3-state output and is terminated with a weak pullup.

*Designer Note: When VBAT is at or below the UVLO trip point voltage, the internal LDO which supplies the xxx\_H host SPI communications pins (VLODx) begins to fall out of regulation. The output high voltage on the xxx\_H pins falls off with the LDO voltage in an approximately linear manner until at the POR voltage trip point it is reduced to approximately 3.5 V. This action is not tested in production.*

## Application Notes on the Host SPI Interface Pin States

The CS\_H pin is active-low. The host asserts the pin to a logic zero to initiate communications. The CS pin should remain low until the end of the current packet. When the CS\_H pin is asserted, the SPI receiver and interface of the device are reset and resynchronized. This action ensures that a slave device that has lost synchronization during a previous transmission or as the result of noise on the bus does not remain permanently hung. CS\_H must be driven false (high) between packets; see *AC Timing Characteristics* for timing details.

## Device-to-Device Vertical Bus (VBUS) Interface

Device-to-device (D2D) communications makes use of a unique, current-mode interface which provides common-mode voltage isolation between successive bq76PL536s. This *vertical bus* (VBUS) is found on the \_N and corresponding \_S pins. It provides high-speed I/O for both the SPI bus and the direct I/O pins CONV and DRDY. The current-mode interface minimizes the effects of wiring capacitance on the interface speed.

The \_S (South-facing) pins connect to the next-lower device (operating at a lower potential) in the stack of bq76PL536s. The \_N (North facing) pins connect to the next-higher device. The pins cannot be swapped; \_S always points South, and \_N always point North. The \_S and \_N pins are interconnected to the pin with the same name, but opposite suffix. All pins operate within the voltages present at the BAT and VSS pins. **Use caution; these pins may be several hundred volts above system ground, depending on their position in the stack.**

*Designer Note: North (\_N) pins of the top, most-positive device in the stack should be connected to the BAT1(2) pins of the device for correct operation of the string. South (\_S) pins of the lowest, most-negative device in the stack should be connected to VSS of the device. The connections may direct, or via a pullup resistor (\_N) or pulldown resistor (\_S) in the range of 100 Ω–1 MΩ.*

The maximum SCLK frequency is limited by the number of devices in the vertical stack and other factors. Each device imposes an approximately 30-nS delay on the round trip communications speed, i.e., from SCLK rising (an input to all devices) to the SDO pin transitioning requires ~30 ns per device. The designer must add to this the delay caused by the PCB trace (in turn determined by the material and layout), any connectors in series with the connection, and any other wiring or cabling between devices in the system. To maximize speed, these other system components should be carefully selected to minimize delays and other detrimental effects on signal quality. Wiring and connectors should receive special attention to their transmission line characteristics.

Other factors which should be considered are clock duty cycle, clock jitter, temperature effects on clock and system components, user-selected drive level for the level-shift interface, and desired design margin.

The VBUS SPI interface is placed in a low-power mode when CS\_H is not asserted on the base device.

The CS\_N/S pins are asserted by a logic high on the vertical interface bus (logically inverted from CS\_H). This creates a default VBUS CS condition of logic low, reducing current consumption to a minimum.

To reduce power consumption of the SPI interface to a minimum, the SCLK\_H and SDI\_H should be maintained at a logic low (de-asserted). The VBUS versions of these signals are not inverted from the host interface. The device also de-asserts by default the SDO\_N/S pins to minimize power consumption.

## Packet Formats

### Data Read Packet

When the bq76PL536 is selected (CS\_S [CS\_H for first device] is active and the bq76PL536 has been addressed) and read request has been initiated, then the data is transmitted on the SDO\_S pin to the SDO\_N pin of the next device down the stack. This continues to the first device in the stack, where the data in from the SDO\_N pin is transmitted to the host via the SDO\_H pin. The device supplying the read data generates a CRC as the last byte sent.

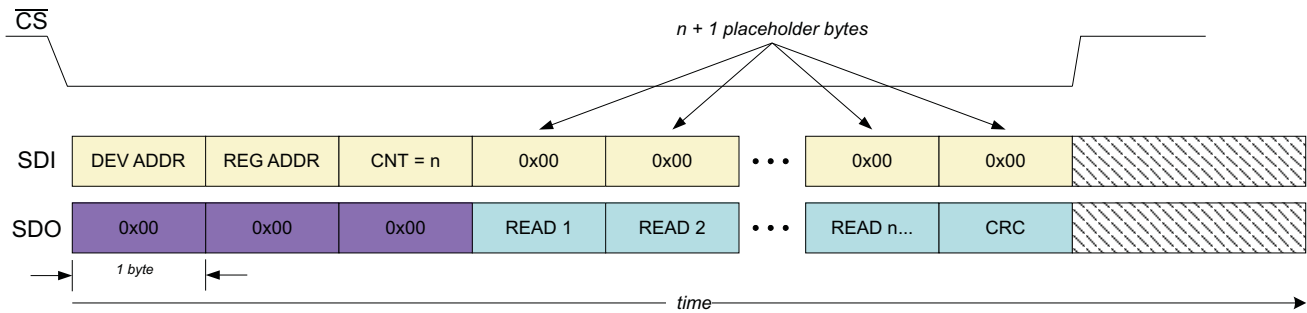

**Figure 8. READ Packet Format**

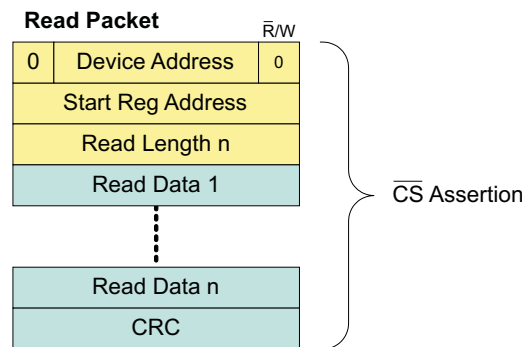
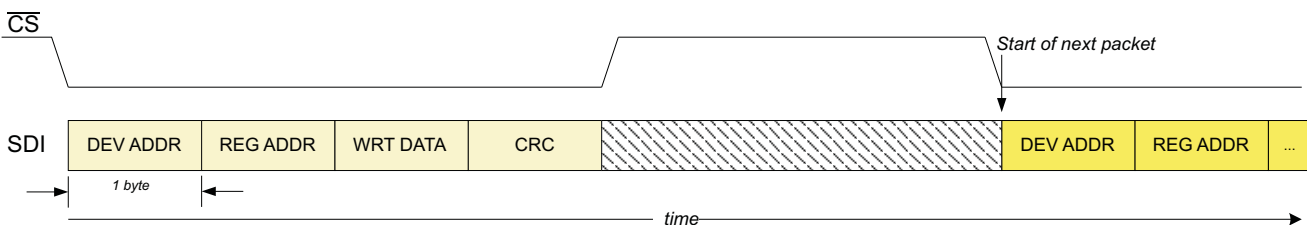

**Figure 9. READ Packet Detail**

**Data Write Packet**

When the bq76PL536 is selected (CS\_S is active and the bq76PL536 has been addressed) and a write request has been initiated, the bq76PL536 receives data through the SDI\_S pin, which is connected to the SDO\_N of the lower device. For the first device in the stack, the data is input to the SDI\_H pin from the host, and transmitted up the stack on the SDI\_S pin to the SDI\_N pin of the next higher device. If enabled, the device checks the CRC, which it expects as the last byte sent. If the CRC is valid, no action is taken. If the CRC is invalid or missing, the device asserts the ALERT\_S signal to the next lower device, which ripples down the stack to the ALERT\_H pin on the lowest device. The host should then take action to clear the condition.

Unused or undefined register bits should be written as zeros.



**Figure 10. WRITE Packet Format**

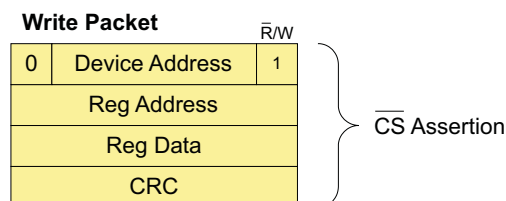

**Figure 11. WRITE Packet Detail**

## Broadcast Writes

The bq76PL536 supports broadcasting single register writes to all devices. A write to device address 0x3f is recognized by all devices on the bus with a valid address, and permits efficient simultaneous configuration of all registers in the stack of devices. This also permits synchronizing all ADC conversions by a firmware command sent to the CONVERT\_CTRL[] register as an alternative to using the CONV and DRDY pins.

## Communications Packet Structure

The bq76PL536 has two primary communication modes via the SPI interface. These two modes enable single-byte read / write and multiple data reads. All writes are single-byte; the logical address is shifted one bit left, and the LSB = 1 for writing.

All transactions are in the form of packets comprising:

BYTE	DESCRIPTION
#1	6-bit bq76PL536 slave address + R/W bit 0b0xxx xxxW
#2	Starting data-register offset
#3	Number of data bytes to be read (n) (omitted for writes)
#4 to 3+n	Data bytes
#4+n	CRC (omit if IO_CONFIG[CRC_DIS] = 1)

## CRC Algorithm

The cyclic redundancy check (CRC) is a CRC-8 error-checking byte, calculated on all the message bytes (including addresses). It is identical in structure to the SMBus 2.0 packet error check (PEC), and is also known as the ATM-8 CRC. The CRC is appended to the message for all SPI packets by the device that supplied the data as the last byte in the packet (when IO\_CONTROL[CRC] == 1).

Each bus transaction requires a CRC calculation by both the transmitter and receiver within each packet. The CRC is calculated in a way that conforms to the polynomial,  $C(x) = x^8 + x^2 + x^1 + 1$  and must be calculated in the order of the bits as received, MSB first. The CRC calculation includes all bytes in the transmission, including address, command, and data. When reading data from the device, the CRC is based on the ADDRESS + FIRST\_REGISTER + LENGTH + returned\_device\_data[n]. The stuff-bytes used to clock out the data from the IC are not used as part of the calculation, although if the value 0x00 is used, the 0s have no effect on the CRC.

CRC verification is performed by the receiver when the CS\_x line goes false, indicating the end of a packet. If the CRC verification fails, the message is ignored (discarded), the CRC failure flag is set in the FAULT\_STATUS[CRC] register, and the FAULT line becomes asserted and latched until the error is read and cleared by the host.

The CRC bit returned in the FAULT\_STATUS[] register reflects the last packet received, not the CRC condition of the packet reading the FAULT\_STATUS contents. CRC errors should be handled at a high priority by the host controller, before writing to additional registers.

## Data Packet Usage Examples

The bq76PL536 can be enabled via the host to read just the specific voltage data which would require a total of 2 written bytes (chip address and R/W [#1] + first (starting) register offset [#2]) + LENGTH [#3] and 13 <null> stuff bytes (12 [n] data bytes + CRC).

The data packet can be periodically expanded to accommodate temperature and GPAI readings as well as device status as needed by changing the REGISTER\_FIRST offset and LENGTH values.

## Device Addressing

Each individual device in the series stack requires an address to allow it to be communicated with. Each bq76PL536 has a CS\_S and CS\_N that are used in assigning addresses. Once addresses have been assigned, the normal operation of the CS\_N/S lines is asserted (logic high) during communications, and the appropriate bq76PL536 in the stack responds according to the address transmitted as part of the packet.

When the bq76PL536 is reset, the DEVICE\_STATUS[AR] (address request) flag is cleared, the address register

## bq76PL536

SLUSA08A –DECEMBER 2009–REVISED JULY 2010

[www.ti.com](http://www.ti.com)

is set to 0x00, and ALERT\_S is set and passed down the stack. In this state, where address = 0x00, the CS\_N signal is forced to a de-asserted state (CS is not passed north when an address = 0). In this manner, after a reset the host is assured that a response at address 0x00 is from the first physical device in the stack. After address assignment of the current device, the host is assured that the next response at address 0x00 is from the next physical device in the stack.

Once a valid address is assigned to the device, the CS\_N signal responds normally, and follows the CS\_H or CS\_S signal, propagating to the next device in the stack. Valid addresses are in the range 0x01 through 0x3e. 0x00 is reserved for device discovery after reset. 0x3f is reserved as a broadcast address for all devices.

*Designer Note: Broadcast messages are only received by devices with a valid address, and the next higher device. Any device with an address of 0x00 blocks messages to devices above it. A broadcast message may not be received by all devices in a stack in situations where some devices do not have a valid address.*

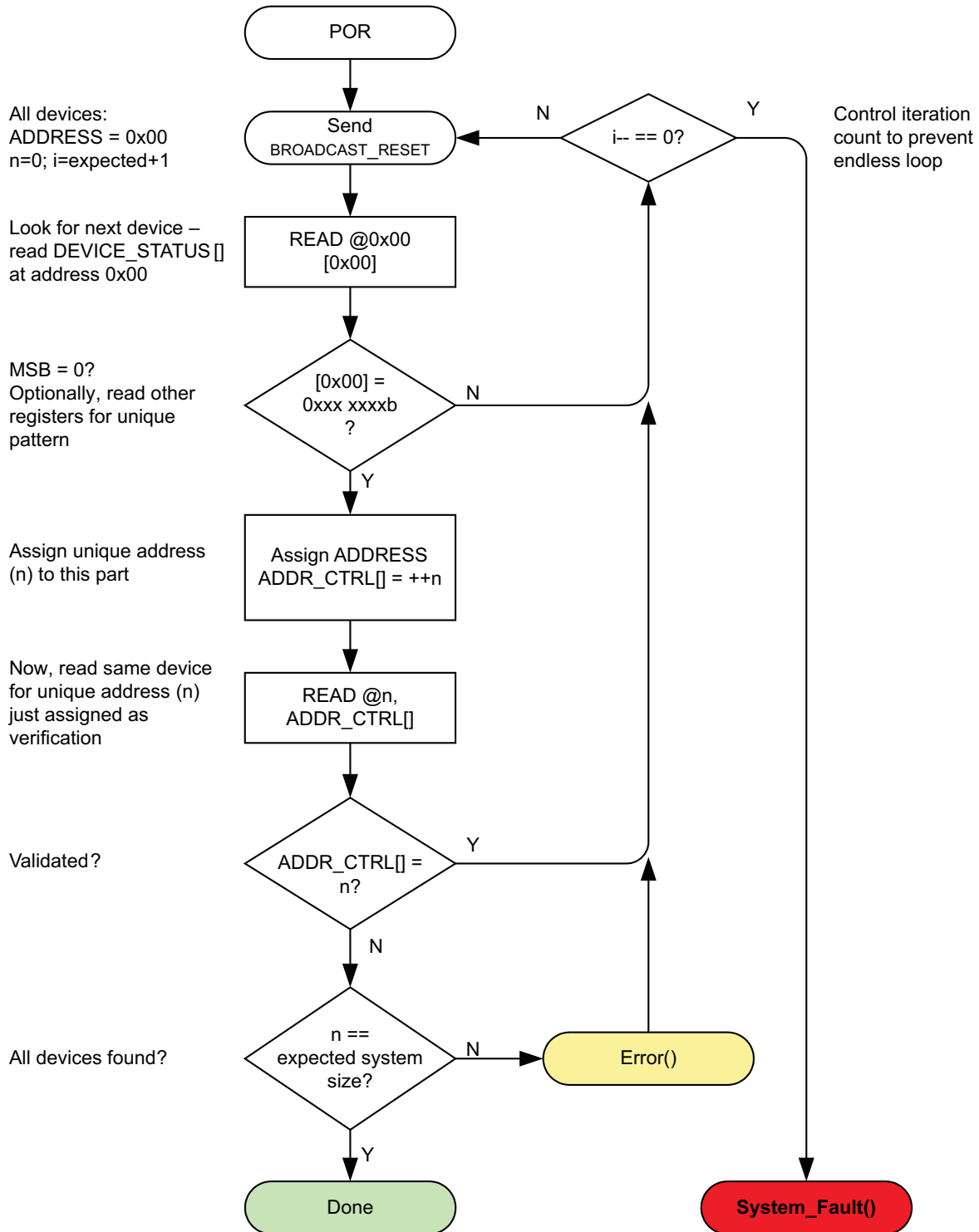

Figure 12. Simple Address Discovery and Assignment Algorithm

Once the address is written the ADDRESS\_CONTROL[AR] bit will be set which is copied to the DEVICE\_STATUS[AR] and also de-asserts ALERT\_S if ALERT\_N is also de-asserted. This allows the CS\_N pin to follow (asserted) the CS\_S pin assertions. The process of addressing can now be repeated as device 'n' has a new address and device n+1 has the default address of 0x00, and can be changed to its *correct* address in the stack.



If a device loses its address through a POR or it is replaced then this device will be the highest logical device in the stack able to be addressed (0x00) as its CS\_N will be disabled and the addressing process is required to be undertaken for this, and higher devices.

## REGISTER ARCHITECTURE

### I/O Register Details

The bq76PL536 has 48 addressable I/O registers. These registers provide status, control, and configuration information for the battery protection system. Reserved registers return 0x00. Unused registers should not be written to; the results are undefined. Unused or undefined bits should be written as zeros, and will always read back as zeros. Several types of registers are provided, detailed as follows.

### Register Types

#### Read-Only (Group 1)

These registers contain the results of conversions, or device status information set by internal logic. The contents are re-initialized by a device reset as a result of either POR or the RESET command. Contents of the register are changed by either a conversion command, or when there is an internal state change (i.e., a fault condition is sensed).

#### Read / Write (Group 2)

This register group modifies the operations or behavior of the device, or indicates detailed status in the ALERT\_STATUS[] and FAULT\_STATUS[] registers. The contents are re-initialized by a device reset as a result of either POR or the RESET command. Contents of the register are changed either by a conversion command, or when there is an internal state change (i.e., a fault condition is sensed).

Contents may also be changed by a write from the host CPU to the register. Writes may only modify a single register at a time. If CRCs are enabled, the write packet is buffered until the CRC is checked for correctness. Packets with bad CRCs are discarded without writing the value to the register, after setting the FAULT\_STATUS[CRC] flag.

Unused or undefined bits in any register should be written as zeros, and will always read back as zeros.

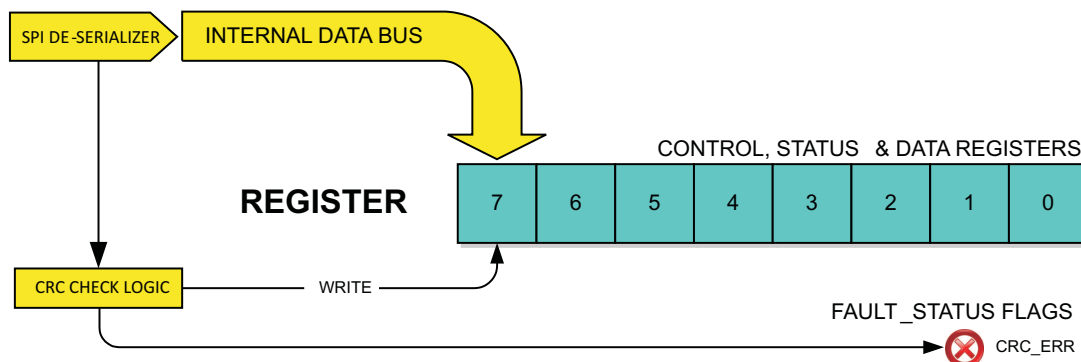

**Figure 13. Register Group-2 Architecture**

#### Read / Write, Initialized From EPROM (Group 3)

These registers control the device configuration and functionality. The contents of the registers are initialized from EPROM-stored constants as a result of POR, RESET command, or the RELOAD\_SHADOW command. This feature ensures that the secondary protector portion of the device (COV, CUV, OT) is fully functional after a reset, without host CPU involvement.



These registers may only be modified by using a special, sequential-write sequence to guard against accidental changes. The value loaded from EPROM at reset (or by command) may be temporarily overridden by using the special write sequence. The temporary value is overwritten to the programmed EPROM initialization value by the next reset or command to reload. To write to these protected registers, first write 0x35 to SHDW\_CONTROL[], immediately followed by the write to the desired register. Any intervening write cancels the special sequence.

To re-initialize the entire set of group-3 registers to the EPROM defaults, write the value 0x27 to SHDW\_CONTROL[].

These registers are further protected against corruption by a ninth parity bit that is automatically updated when the register is written using even parity. If the contents of the register ever become corrupted, the bad parity causes the ALERT\_STATUS[PARITY] bit to become set, alerting the host CPU of the problem.

The EPROM-stored constants are programmed by writing the values to the register(s), then applying the programming voltage to the LDODx pins, then issuing the EPROM\_WRITE command to register E\_EN[]. All group-3 registers are programmed simultaneously, and this operation can only be performed once to the one-time-programmable (OTP) memory cells. The process is not reversible.

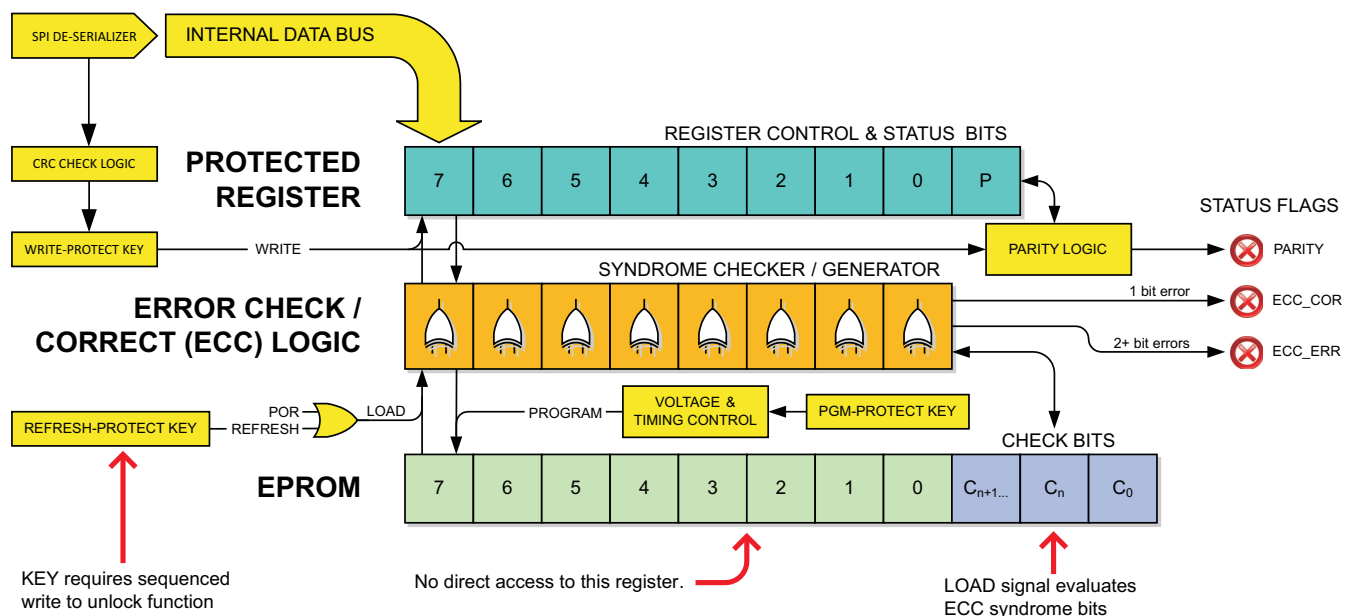

Figure 14. Protected Register Group-3 Architecture, Simplified View

### Error Checking and Correcting (ECC) EPROM

The EPROM used to initialize this group is also protected by error-check-and-correct (ECC) logic. The ECC bits provide a highly reliable storage solution in the presence of external disturbances. This feature cannot be disabled by user action. Implementation is fully self-contained and automatic and requires no special computations or provisioning by the user.

When the group-3 contents are permanently written to EPROM, an additional array of hidden ECC-OTP cells is also automatically programmed. The ECC logic implements a Hamming code that automatically corrects all single-bit errors in the EPROM array, and senses additional multi-bit errors. If any corrections are made, the DEVICE\_STATUS[ECC\_COR] flag bit is set. If any multi-bit errors are sensed, the ALERT\_STATUS[ECC\_ERR] flag is set. The corrective action or detection is performed anytime the contents of EPROM are loaded into the registers – POR, RESET, or by SHADOW\_LOAD command. *Note: The ECC\_COR and ECC\_ERR bits may glitch during OTP-EPROM writes; this is normal. If this occurs, reset the tripped bit; it should remain cleared.*

When a double-bit (uncorrectable) error is found, DEVICE\_STATUS[ALERT] is set, the ALERT\_S (ALERT\_H for bottom stack device) line is activated, and the ALERT\_STATUS[] register returns the ECC\_ERR and/or I\_FAULT bit = 1(true). *The device may return erroneous measurement data, and/or fail to detect COV, CUV, or OT faults in this state.*

EPROM bits are shipped from the factory set to 0, and must be programmed to the 1 state as required.

**Table 4. Data and Control Register Descriptions**

NAME	ADDR	GROUP	ACCESS <sup>(1)</sup>	RESET	DESCRIPTION
DEVICE_STATUS	0x00	1	R	0	Status register
GPAI	0x01, 0x02	1	R	0	GPAI measurement data
VCELL1	0x03, 0x04	1	R	0	Cell 1 voltage data
VCELL2	0x05, 0x06	1	R	0	Cell 2 voltage data
VCELL3	0x07, 0x08	1	R	0	Cell 3 voltage data
VCELL4	0x09, 0x0a	1	R	0	Cell 4 voltage data
VCELL5	0x0b, 0x0c	1	R	0	Cell 5 voltage data
VCELL6	0x0d, 0x0e	1	R	0	Cell 6 voltage data
TEMPERATURE1	0x0f, 0x10	1	R	0	TS1+ to TS1– differential voltage data
TEMPERATURE2	0x11, 0x12	1	R	0	TS2+ to TS2– differential voltage data
RSVD	0x13–0x1f	–	–	–	Reserved for future use
ALERT_STATUS	0x20	2	R/W	0x80	Indicates source of ALERT signal
FAULT_STATUS	0x21	2	R/W	0x08	Indicates source of FAULT signal
COV_FAULT	0x22	1	R	0	Indicates cell in OV fault state
CUV_FAULT	0x23	1	R	0	Indicates cell in UV fault state
PRESULT_A	0x24	1	R	0	Parity result of group-3 protected registers (A)
PRESULT_B	0x25	1	R	0	Parity result of group-3 protected registers (B)
RSVD	0x26–0x2f	–	–	–	Reserved for future use
ADC_CONTROL	0x30	2	R/W	0	ADC measurement control
IO_CONTROL	0x31	2	R/W	0	I/O pin control
CB_CTRL	0x32	2	R/W	0	Controls the state of the cell-balancing outputs CBx
CB_TIME	0x33	2	R/W	0	Configures the CB control FETs maximum on time
ADC_CONVERT	0x34	2	R/W	0	ADC conversion start
RSVD	0x35–0x39	–	–	–	Reserved for future use
SHDW_CTRL	0x3a	2	R/W	0	Controls WRITE access to group-3 registers
ADDRESS_CONTROL	0x3b	2	R/W	0	Address register
RESET	0x3c	2	W	0	RESET control register
TEST_SELECT	0x3d	2	R/W	0	Test mode selection register
RSVD	0x3e	–	–	–	Reserved for future use
E_EN	0x3f	2	R/W	0	EPROM programming mode enable
FUNCTION_CONFIG	0x40	3	R/W	EPROM	Default configuration of device
IO_CONFIG	0x41	3	R/W	EPROM	I/O pin configuration
CONFIG_COV	0x42	3	R/W	EPROM	Overvoltage set point
CONFIG_COVT	0x43	3	R/W	EPROM	Overvoltage time-delay filter
CONFIG_CUV	0x44	3	R/W	EPROM	Undervoltage setpoint
CONFIG_CUVT	0x45	3	R/W	EPROM	Undervoltage time-delay filter
CONFIG_OT	0x46	3	R/W	EPROM	Overtemperature set point
CONFIG_OTT	0x47	3	R/W	EPROM	Overtemperature time-delay filter
USER1	0x48	3	R	EPROM	User data register 1, not used by device
USER2	0x49	3	R	EPROM	User data register 2, not used by device
USER3	0x4a	3	R	EPROM	User data register 3, not used by device
USER4	0x4b	3	R	EPROM	User data register 4, not used by device
RSVD	0x4c–0xff	–	–	–	Reserved

(1) Key: R = Read; W = Write

## REGISTER DETAILS

### DEVICE\_STATUS REGISTER (0x00)

7	6	5	4	3	2	1	0
AR	FAULT	ALERT	–	ECC_COR	UVLO	CBT	DRDY

The STATUS register provides information about the current state of the bq76PL536.

- [7] (ADDR\_RQST) This bit is written to indicate that the ADDR[0]...[5] bits have been written to the correct address. This bit is a copy of in the ADDRESS\_CONTROL[AR] bit.
- 0 = Address has not been assigned
  - 1 = Address has been assigned
- [6] (FAULT): This bit indicates that this bq76PL536 has detected a condition causing the FAULT signal to become asserted.
- 0 = No FAULT exists
  - 1 = A FAULT exists. Read FAULT\_STATUS[] to determine the cause.
- [5] (ALERT): This bit indicates that this bq76PL536 has detected a condition causing the ALERT pin to become asserted.
- 0 = No FAULT exists
  - 1 = An ALERT exists. Read ALERT\_STATUS[] to determine the cause.
- [4] (not implemented)
- [3] (ECC\_COR): This bit indicates a one-bit error has been detected and corrected in the EPROM.
- 0 = No errors are detected in the EPROM
  - 1 = A one-bit (single bit) error has been detected and corrected by on-chip logic.
- [2] (UVLO): This bit indicates the device VBAT has fallen below the undervoltage lockout trip point. Some device operations are not valid in this condition.
- 0 = Normal operation
  - 1 = UVLO trip point reached, device operation is **not** ensured.
- [1] (CBT): This bit indicates the cell balance timer is running.
- 0 = The cell balance timer is has not started or has expired.
  - 1 = The cell balance timer is running.
- [0] (DRDY): This bit indicates the data is ready to read (no conversions active).
- 0 = There are conversion(s) running.
  - 1 = There are no conversion(s) running.

**GPAl (0x01, 0x02)**

15	14	13	12	11	10	9	8
GPAl[15]	GPAl [14]	GPAl [13]	GPAl [12]	GPAl [11]	GPAl [10]	GPAl [9]	GPAl [8]
7	6	5	4	3	2	1	0
GPAl [7]	GPAl [6]	GPAl [5]	GPAl [4]	GPAl [3]	GPAl [2]	GPAl [1]	GPAl [0]

The GPAl register reports the ADC measurement of GPAl+/GPAl– in units of LSBs.

Bits 15–8 are returned at address 0x01, bits 7–0 at address 0x02.

**VCELLn REGISTER (0x03...0x0e)**

15	14	13	12	11	10	9	8
VCELLn[15]	VCELLn[14]	VCELLn[13]	VCELLn[12]	VCELLn[11]	VCELLn[10]	VCELLn[9]	VCELLn[8]
7	6	5	4	3	2	1	0
VCELLn[7]	VCELLn[6]	VCELLn[5]	VCELLn[4]	VCELLn[3]	VCELLn[2]	VCELLn[1]	VCELLn[0]

The VCELLn registers report the converted data for cell n, where n = 1 to 6.

Bits 15–8 are returned at odd addresses (e.g. 0x03), bits 7–0 at even addresses (e.g. 0x04).

**TEMPERATURE1 REGISTER (0x0f, 0x10)**

15	14	13	12	11	10	9	8
TEMP1[15]	TEMP1[14]	TEMP1[13]	TEMP1[12]	TEMP1[11]	TEMP1[10]	TEMP1[9]	TEMP1[8]
7	6	5	4	3	2	1	0
TEMP1[7]	TEMP1[6]	TEMP1[5]	TEMP1[4]	TEMP1[3]	TEMP1[2]	TEMP1[1]	TEMP1[0]

The TEMPERATURE1 register reports the converted data for TS1+ to TS1–.

Bits 15–8 are returned at odd addresses (e.g., 0x0f), bits 7–0 at even addresses (e.g., 0x10).

**TEMPERATURE2 REGISTER (0x11, 0x12)**

15	14	13	12	11	10	9	8
TEMP2[15]	TEMP2[14]	TEMP2[13]	TEMP2[12]	TEMP2[11]	TEMP2[10]	TEMP2[9]	TEMP2[8]
7	6	5	4	3	2	1	0
TEMP2[7]	TEMP2[6]	TEMP2[5]	TEMP2[4]	TEMP2[3]	TEMP2[2]	TEMP2[1]	TEMP2[0]

The TEMPERATURE2 register reports the converted data for TS2+ to TS2–.

Bits 15–8 are returned at odd addresses (e.g., 0x11), bits 7–0 at even addresses (e.g., 0x12).

**ALERT\_STATUS REGISTER (0x20)**

7	6	5	4	3	2	1	0
AR	PARITY	ECC_ERR	FORCE	TSD	SLEEP	OT2	OT1

The ALERT\_STATUS register provides information about the source of the ALERT signal. The host must clear each alert flag by writing a 1 to the bit that is set. The exception is bit 4, which may be written 1 or 0 as needed to implement self-test of the IC stack and wiring.

[7] AR

This bit indicates that the ADDR[0]...[5] bits have been written to a valid address. This bit is an inverted copy of the ADDRESS\_CONTROL[AR] bit. It is not cleared until an address has been programmed in ADDRESS\_CONTROL and a 1 followed by a 0 (two writes) is written to the bit.

0 = Address has been assigned.

1 = Address has not been assigned (default at RESET).

- [6] (PARITY): This bit is used to validate the contents of the protected group-3 registers.  
0 = Group-3 protected register(s) contents are valid.  
1 = Group-3 protected register(s) contents are invalid. Group-3 registers should be refreshed from OTP or directly written from the host.
- [5] (ECC\_ERR): This bit is used to validate the OTP register blocks.  
0 = No double-bit errors (a corrected one-bit error may/may not exist)  
1 = An uncorrectable error has been detected in the OTP-EEPROM register bank. OTP-EEPROM register(s) are not valid.
- [4] (FORCE): This bit asserts the ALERT signal. It can be used to verify correct operation and connectivity of the ALERT as a part of system self-test.  
0 = Deassert ALERT (default)  
1 = Assert the ALERT signal.
- [3] (TSD): This bit indicates thermal shutdown is active.  
0 = Thermal shutdown is inactive (default).  
1 = Die temperature has exceeded  $T_{SD}$ .
- [2] (SLEEP): This bit indicates SLEEP mode was activated. This bit is only set when SLEEP is first activated; no continuous ALERT or SLEEP status is indicated after the host resets the bit, even if the IO\_CTRL[SLEEP] bit remains true. (See IO\_CTRL[] register for details.)  
0 = Normal operation  
1 = SLEEP mode was activated.
- [1] (OT2): This bit indicates an overtemperature fault has been detected via TS2.  
0 = Temperature is lower than or equal to the  $V_{OT2}$  (or input disabled by IO\_CONTROL[TS2] = 0).  
1 = Temperature is higher than  $V_{OT2}$ .
- [0] (OT1): This bit indicates an overtemperature fault has been detected via TS1.  
0 = Temperature is lower than or equal to the  $V_{OT1}$  (or input disabled by IO\_CONTROL[TS1] = 0).  
1 = Temperature is higher than  $V_{OT1}$ .

**FAULT\_STATUS REGISTER (0x21)**

7	6	5	4	3	2	1	0
–	–	I_FAULT	FORCE	POR	CRC	CUV	COV

The FAULT\_STATUS register provides information about the source of the FAULT signal. The host must clear each fault flag by writing a 1 to the bit that is set. The exception is bit 4, which may be written 1 or 0 as needed to implement self-test of the IC stack and wiring.

[7] (not implemented)

[6] (not implemented)

- [5] (I\_FAULT): The device has failed an internal register consistency check. Measurement data and protection function status may not be accurate and should not be used.  
0 = No internal register consistency check fault exists.

1 = The internal consistency check has failed self-test. The host should attempt to reset the device, see the *RESET* section. If the fault persists, the failure should be considered uncorrectable.

[4] (FORCE): This bit asserts the FAULT signal. It can be used to verify correct operation and connectivity of the FAULT line as a part of system self-test.

0 = Deassert FAULT (default)

1 = Assert the FAULT signal.

[3] (POR): This bit indicates a power-on reset has occurred.

0 = No POR has occurred since this bit was last cleared by the host.

1 = A POR has occurred. This notifies the host that default values have been loaded to group-1, -2 registers, and OTP contents have been copied to group-3 registers.

[2] (CRC): This bit indicates a garbled packet reception by the device.

0 = No errors

1 = A CRC error was detected in the last packet received.

[1] (CUV): This bit indicates that this bq76PL536 has detected a cell undervoltage (CUV) condition. Examine CUV\_FAULT[] to determine which cell caused the ALERT.

0 = All cells are above the CUV threshold (default).

1 = One or more cells is below the CUV threshold.

[0] (COV): This bit indicates that this bq76PL536 has detected a cell overvoltage (COV) condition. Examine COV\_FAULT[] to determine which cell caused the FAULT.

0 = All cells are below the COV threshold (default).

1 = One or more cells is above the COV threshold.

### COV\_FAULT REGISTER (0x22)

7	6	5	4	3	2	1	0
–	–	OV[6]	OV[5]	OV[4]	OV[3]	OV[2]	OV[1]

[0..5] (OV[1]..[6]): These bits indicate which cell caused the DEVICE\_STATUS[COV] flag to be set.

0 = Cell[n] does not have an overvoltage fault (default).

1 = Cell[n] does have an overvoltage fault.

### COV\_FAULT REGISTER (0x23)

7	6	5	4	3	2	1	0
–	–	UV[6]	UV[5]	UV[4]	UV[3]	UV[2]	UV[1]

b0..5 (UV[1]..[6]): These bits indicate which cell caused the DEVICE\_STATUS[CUV] flag to be set.

0 = Cell[n] does not have an overvoltage fault (default).

1 = Cell[n] does have an overvoltage fault.

### PARITY\_H REGISTER (0x24) (PRESULT\_A (R/O))

7	6	5	4	3	2	1	0
OTT	OTV	CUVT	CUVV	COVT	COVV	IO	FUNC

The PRESULT\_A register holds the parity result bits for the first eight group-3 protected registers.

#### PARITY\_H REGISTER (0x25) (PRESULT\_B (R/O))

7	6	5	4	3	2	1	0
0	0	0	0	USER4	USER3	USER2	USER1

The PRESULT\_B register holds the parity result bits for the first eight group-3 protected registers.

#### ADC\_CONTROL REGISTER (0x30)

7	6	5	4	3	2	1	0
–	ADC_ON	TS2	TS1	GPAI	CELL_SEL[2]	CELL_SEL[1]	CELL_SEL[0]

The ADC\_CONTROL register controls some features of the bq76PL536.

[7] *not implemented. Must be written as 0.*

[6] (ADC\_ON): This bit forces the ADC subsystem ON. This has the effect of eliminating internal start-up and settling delays, but increases current consumption.

0 = Auto mode. ADC subsystem is OFF until a conversion is requested. The ADC is turned on, a wait is applied to allow the reference to stabilize. Automatically returns to OFF state at end of requested conversion. Note that there is a start-up delay associated with turning the ADC to the ON state in this mode.

1 = ADC subsystem is ON, regardless of conversion state. Power consumption is increased.

[5..4] (TS[1]..[0]): These two bits select whether any of the temperature sensor inputs are to be measured on the next conversion sequence start.

TS[1]	TS[0]	Measure T
0	0	None (default)
0	1	TS1
1	0	TS2
1	1	Both

[3] (GPAI): This bit enables and disables the GPAI input to be measured on the next conversion-sequence start.

0 = GPAI is not selected for measurement.

1 = GPAI is selected for measurement.

[2–0] (CELL\_SEL): These three bits select the series cells for voltage measurement translation on the next conversion sequence start.

CELL_SEL[2]	CELL_SEL[1]	CELL_SEL[0]	SELECTED CELL
0	0	0	Cell 1 only
0	0	1	Cells 1-2
0	1	0	Cells 1-2-3
0	1	1	Cells 1-2-3-4
1	0	0	Cells 1-2-3-4-5
1	0	1	Cells 1-2-3-4-5-6
Other			Cell 1 only

**bq76PL536**

SLUSA08A –DECEMBER 2009–REVISED JULY 2010

[www.ti.com](http://www.ti.com)
**IO\_CONTROL REGISTER (0x31)**

7	6	5	4	3	2	1	0
AUX	GIPI_OUT	GPIO_IN	0	0	SLEEP	TS2	TS1

The IO\_CONTROL register controls some features of the bq76PL536 external I/O pins.

- [7] (AUX): Controls the state of the AUX output pin, which is internally connected to REG50.  
 0 = Open  
 1 = Connected to REG50
- [6] (GPIO\_OUT): Controls the state of the open-drain GPIO output pin; the pin should be programmed to 1 to use the GPIO pin as an input.  
 0 = Output low  
 1 = Open-drain
- [5] (GPIO\_IN): Represents the input state of GPIO pin when used as an input  
 0 = GPIO input is low.  
 1 = GPIO input is high.
- [4] *Not implemented. Must be written as 0.*
- [3] *Not implemented. Must be written as 0.*
- [2] (SLEEP): Places the device in a low-quiescent-current state. All CUV, COV, and OT comparators are disabled. A 1-ms delay to stabilize the reference voltage is required to exit SLEEP mode and return to active COV, CUV monitoring.  
 0 = ACTIVE mode  
 1 = SLEEP mode
- [1..0] (TSx) Controls the connection of the TS1(2) inputs to the ADC VSS connection point. When set, the TSx(–) input is connected to VSS. These bits should be set to 0 to reduce the current draw of the system.  
 0 = Not connected  
 1 = Connected

**CB\_CTRL REGISTER (0x32)**

7	6	5	4	3	2	1	0
–	–	CBAL[6]	CBAL[5]	CBAL[4]	CBAL[3]	CBAL[2]	CBAL[1]

The CB\_CTRL register determines the internal cell balance output state.

- CB\_CTRL b(n = 5 to 0) (CBAL(n + 1)): This bit determines if the CB(n) output is high or low.  
 0 = CB[n] output is low (default).  
 1 = CB[n] output is high (active).



**CB\_TIME REGISTER (0x33)**

7	6	5	4	3	2	1	0
CBT[7]	–	CBT[5]	CBT[4]	CBT[3]	CBT[2]	CBT[1]	CBT[0]

The CB\_TIME register sets the maximum high (active) time for the cell balance outputs from 0 seconds to 63 minutes. When set to 0, no balancing can occur – balancing is effectively disabled.

[7] Controls minutes/seconds counting resolution.

0 = Seconds (default)

1 = Minutes

[5..0] Sets the time duration as scaled by CBT.7

**ADC\_CONVERT REGISTER (0x34)**

7	6	5	4	3	2	1	0
–	–	–	–	–	–	–	CONV

The CONVERT\_CTRL register is used to start conversions.

[0] (CONV): This bit starts a conversion, using the settings programmed into the ADC\_CONTROL[] register. It provides a programmatic method of initiating conversions.

0 = No conversion (default)

1 = Initiate conversion. This bit is automatically reset after conversion begins, and always returns 0 on READ.

**SHDW\_CTRL REGISTER (0x3a)**

7	6	5	4	3	2	1	0
SHDW[7]	SHDW[6]	SHDW[5]	SHDW[4]	SHDW[3]	SHDW[2]	SHDW[1]	SHDW[0]

The SHDW\_CTRL register controls writing to group-3 protected registers. Default at RESET = 0x00.

The value 0x35 must be written to this register to allow writing to group-3 protected registers in the range 0x40–0x4f. The register always returns 0x00 on read. The register is reset to 0x00 after any successful write, including a write to non-group-3 registers. A read operation does not reset this register.

Writing the value 0x27 results in all group-3 protected registers being refreshed from OTP programmed values. The register is reset to 0x00 after the REFRESH is complete.

## bq76PL536

SLUSA08A –DECEMBER 2009–REVISED JULY 2010

[www.ti.com](http://www.ti.com)

### ADDRESS\_CONTROL REGISTER (0x3b)

7	6	5	4	3	2	1	0
AR	0	ADDR[5]	ADDR[4]	ADDR[3]	ADDR[2]	ADDR[1]	ADDR[0]

The ADDRESS\_CONTROL register allows the host to assign an address to the bq76PL536 for communication. The default for this register is 0x00 at RESET.

[7] (ADDR\_RQST): This bit is written to indicate that the ADDR[0]...[5] bits have been written to the correct address. This bit is reflected in the DEVICE\_STATUS[AR] bit

- 0 = Address has not been assigned (default at RESET).
- 1 = Address has been assigned.

[5..0] (ADDR): These bits set the device address for SPI communication. This provides to a range of addresses from 0x00 to 0x3f. Address 0x3f is reserved for broadcast messages to all connected **and** addressed 76PL536 devices. The default for these 6 bits is 0x00 at RESET.

### RESET REGISTER (0x3c)

7	6	5	4	3	2	1	0
RST[7]	RST[6]	RST[5]	RST[4]	RST[3]	RST[2]	RST[1]	RST[0]

The RESET register allows the host to reset the bq76PL536 directly.

Writing 0xa5 causes the device to RESET. Other values are ignored.

### TEST\_SELECT REGISTER (0x3d)

7	6	5	4	3	2	1	0
TSEL[7]	TSEL[6]	TSEL[5]	TSEL[4]	TSEL[3]	TSEL[2]	TSEL[1]	TSEL[0]

The TEST\_SELECT places the SPI port in a special mode useful for debug.

TSEL (b7–b0) is used to place the SPI\_H interface pins in a mode to support test/debug of a string of bq76PL536 devices. 0 = normal operating mode.

When the sequence 0xa4, 0x25 ("JR") is written on subsequent write cycles, the device enters a special TEST mode useful for stack debugging. Writes to other registers between the required sequence bytes results in the partial sequence being voided; the entire sequence must be written again. POR, RESET, or writing a 0x00 to this register location exits this mode.

In this state, SPI pin SCLK and SDI become outputs and are enabled, and reflect the state of the SCLK\_S, SDI\_S pins of the device. SDO remains an output. This allows observation of bus traffic mid-string. The lowest device in the string should **not** be set to operate in this mode. *The user is cautioned to condition the connection to a mid- or top-string device with suitable isolation circuitry to prevent injury or damage to connected devices. Programming the most-negative device on the stack in this mode prevents further communications with the stack until POR, and may result in device destruction; this condition should be avoided.*

### E\_EN REGISTER (0x3f)

7	6	5	4	3	2	1	0
E_EN[7]	E_EN [6]	E_EN [5]	E_EN [4]	E_EN [3]	E_EN [2]	E_EN [1]	E_EN [0]

The E\_EN register controls the access to the programming of the integrated OTP EPROM.

This register should be written the value 0x91 to permit writing the USER block of EPROM. Values other than 0x00 and 0x91 are reserved and may result in undefined operation. The next read or write of any type to the device resets (closes) the write window. If a group-3 protected write occurs, the window is closed after the write.

**FUNCTION\_CONFIG REGISTER (0x40)**

7	6	5	4	3	2	1	0
ADCT[1]	ADCT[0]	GPAI_REF	GPAI_SRC	CN[1]	CN[0]	–	0

The FUNCTION\_CONFIG sets the default configuration for special features of the device.

[7..6] (ADCT[0,1]): These bits set the conversion timing of the ADC measurement.

ADCT[1]	ADCT[0]	~Conversion Time (μs)
0	0	3
0	1	6 (recommended)
1	0	12
1	1	24

[5] (GPAI\_REF): This bit sets the reference for the GPAI ADC measurement.

0 = Internal ADC bandgap reference

1 =  $V_{REG50}$  (ratiometric)

[4] (GPAI\_SRC): This bit controls multiplexing of the GPAI register and determines whether the ADC mux is connected to the external GPAI inputs, or internally to the BAT1 pin. The register results are automatically scaled to match the input.

0 = External GPAI inputs are converted to result in GPAI register 0x01–02.

1 = BAT pin to VSS voltage is measured and reported in the GPAI register.

[3..2] (CN[1..0]): These two bits configure the number of series cells used. If fewer than 6 cells are configured, the corresponding OV/UV faults are ignored. For example, if the CN[x] bits are set to 10b (2), then the OV/UV comparators are ignored for cells 5 and 6.

CN[1]	CN[0]	SERIES CELLS
0	0	6 (DEFAULT)
0	1	5
1	0	4
1	1	3

**IO\_CONFIG REGISTER (0x41)**

7	6	5	4	3	2	1	0
–	–	–	–	–	–	–	CRC_DIS

The IO\_CONFIG sets the default configuration for miscellaneous I/O features of the device.

[0] (CRC\_DIS): This bit enables and disables the automatic generation of the CRC for the SPI communication packet. The packet size is determined by the host as part of the read request protocol. The CRC is checked at the deassertion of the CS pin. TI recommends that this bit be changed using the broadcast address (0x3f) so that all devices in a battery stack use the same protocol.

0 = A CRC is expected, and generated as the last byte of the packet.

1 = A CRC is not used in communications.

**bq76PL536**

SLUSA08A –DECEMBER 2009–REVISED JULY 2010

[www.ti.com](http://www.ti.com)
**CONFIG\_COV REGISTER (0x42)**

7	6	5	4	3	2	1	0
DISABLE	–	COV[5]	COV[4]	COV[3]	COV[2]	COV[1]	COV[0]

The CONFIG\_COV register determines cell overvoltage threshold voltage.

- [7] (DISABLE): Disables the overvoltage function when set  
 0 = Overvoltage function enabled  
 1 = Overvoltage function disabled
- [5..0] (COV[5]...[0]): Configuration bits with corresponding voltage threshold  
 0x00 = 2 V; each binary increment adds 50 mV until 0x3c = 5 V.

**CONFIG\_COVT REGISTER (0x43)**

7	6	5	4	3	2	1	0
μs/ms	–	–	COVD[4]	COVD[3]	COVD[2]	COVD[1]	COVD[0]

The CONFIG\_COVT register determines cell overvoltage detection delay time.

- [7] (μs/ms): Determines the units of the delay time, microseconds or milliseconds  
 0 = Microseconds  
 1 = Milliseconds
- [4..0] COVD: 0x01 = 100; each binary increment adds 100 until 0x1f = 3100  
*Note: When this register is programmed to 0x00, the delay becomes 0s AND the COV state is NOT latched in the COV\_FAULT[] register. In this operating mode, the overvoltage state for a cell is virtually instantaneous in the COV\_FAULT[] register. This mode may cause system firmware to miss a dangerous cell overvoltage condition.*

**CONFIG\_UV REGISTER (0x44)**

7	6	5	4	3	2	1	0
DISABLE	–	–	CUV[4]	CUV[3]	CUV[2]	CUV[1]	CUV[0]

The CUV register determines cell under voltage threshold voltage.

- [7] (DISABLE): Disables the undervoltage function when set  
 0 = Undervoltage function enabled  
 1 = Undervoltage function disabled
- [5..0] (CUV[4]...[0]): Configuration bits with corresponding voltage threshold  
 0x00 = 0.7 V; each binary increment adds 100 mV until 0x1a = 3.3 V.

**CONFIG\_CUVT REGISTER (0x45)**

7	6	5	4	3	2	1	0
μs/ms	–	–	CUVD[4]	CUVD[3]	CUVD[2]	CUVD[1]	CUVD[0]

The CONFIG\_CUVT register determines cell overvoltage detection delay time.

[7] (μs/ms): Determines the units of the delay time, microseconds or milliseconds

0 = Microseconds

1 = Milliseconds

[4..0] CUVD: 0x01 = 100; each binary increment adds 100 until 0x1f = 3100.

*Note: When this register is programmed to 0x00, the delay becomes 0s AND the CUV state is NOT latched in the CUV\_FAULT[] register. In this operating mode, the overvoltage state for a cell is virtually instantaneous in the CUV\_FAULT[] register. This mode may cause system firmware to miss a dangerous cell undervoltage condition.*

**CONFIG\_OT REGISTER (0x46)**

7	6	5	4	3	2	1	0
OT2[3]	OT2[2]	OT2[1]	OT2[0]	OT1[3]	OT1[2]	OT1[1]	OT1[0]

The CONFIG\_OT register holds the configuration of the overtemperature thresholds for the two TS inputs.

For each respective nibble (OT1 or OT2), the value 0x0 disables this function. Other settings program a trip threshold. See the *Ratiometric Sensing* section for details of setting this register. Values above 0x0b are illegal and should not be used.

**CONFIG\_OTT REGISTER (0x47)**

7	6	5	4	3	2	1	0
COTD[7]	COTD[6]	COTD[5]	COTD[4]	COTD[3]	COTD[2]	COTD[1]	COTD[0]

The CONFIG\_OTT register determines cell overtemperature detection delay time.

0x01 = 10 ms; each binary increment adds 10 ms until 0xff = 2.55 seconds.

*Note: When this register is programmed to 0x00, the delay becomes 0s AND the OT state is NOT latched in the ALERT\_STATUS[] register. In this operating mode, the overtemperature state for a TS<sub>n</sub> input is virtually instantaneous in the register. This mode may cause system firmware to miss a dangerous overtemperature condition.*

**USERx REGISTER (0x48–0x4b) (USER1–4)**

7	6	5	4	3	2	1	0
USER[7]	USER[6]	USER[5]	USER[4]	USER[3]	USER[2]	USER[1]	USER[0]

The four USER registers can be used to store user data. The part does not use these registers for any internal function. They are provided as convenient storage for user S/N, date of manufacture, etc.

## PROGRAMMING THE EPROM CONFIGURATION REGISTERS

The bq76PL536 has a block of OTP-EPROM that is used for configuring the operation of the bq76PL536. Programming of the EPROM should take place during pack/system manufacturing. A 7-V ( $V_{PP}$ ) pulse is required on the PROG pin. The part uses an internal window comparator to check the voltage, and times the internal pulse delivered to the EPROM array.

The user first writes the desired values to all of the equivalent group-3 protected register addresses. The desired data is written to the appropriate address by first applying 7 V to the LDOD1(2) pins. Programming then performed by writing to the EE\_EN register (address 0x3f) with data 0x91. After a time period > 1500  $\mu$ s, the 7 V is removed. Nominally, the voltage pulse should be applied for approximately 2–3 ms. Applying the voltage for an extended period of time may lead to device damage. The write is self-timed internally after receipt of the command. The following flow chart illustrates the procedure for programming.

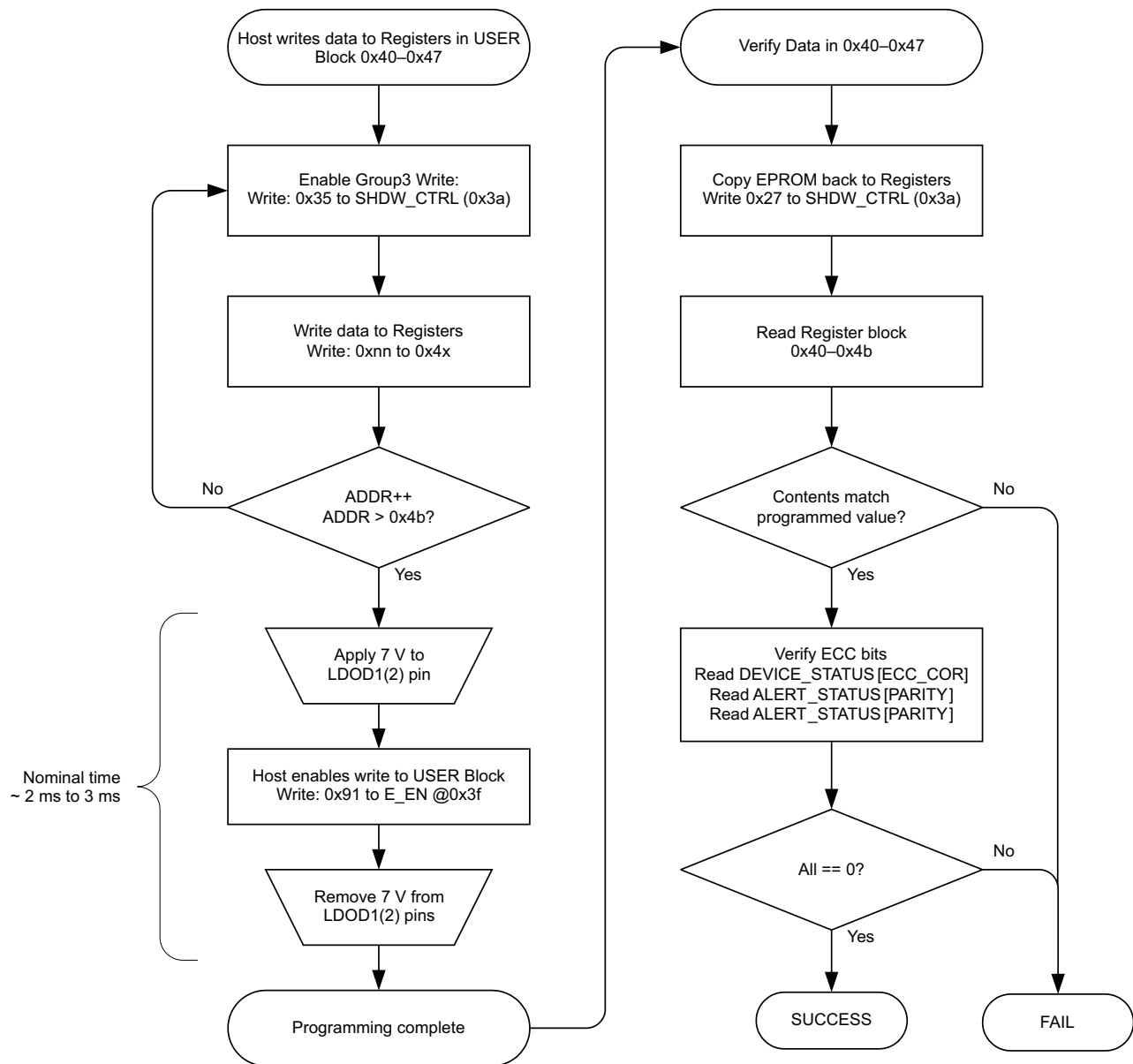

**Figure 15. EPROM Programming**

**REFERENCE SCHEMATIC**

**INDIVIDUAL GROUND PLANES ARE NECESSARY FOR PROPER NOISE REJECTION AND STABILITY OF THESE CIRCUITS**  
**NOTE:** The ground reference per circuit block is unique. The most negative connection of CELLO is the ground reference for each chip.  
**DO NOT** connect ground references from different chips.  
 Only the ground reference CELLO of circuit 1 is safe to connect non-isolated test equipment grounds.

S001

**CAUTION**  
HIGH VOLTAGE

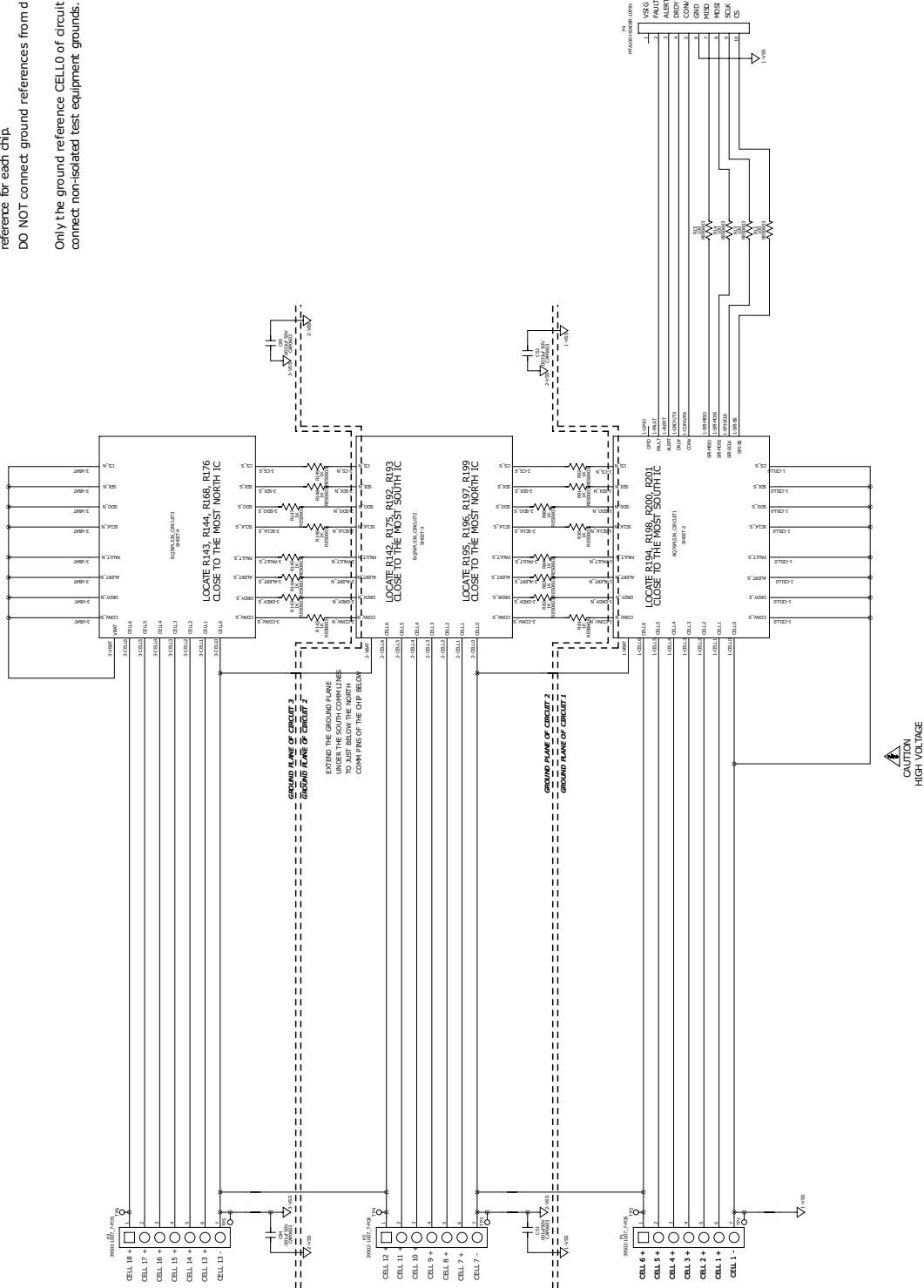

**Figure 16. Schematic (Page 1 of 4)**



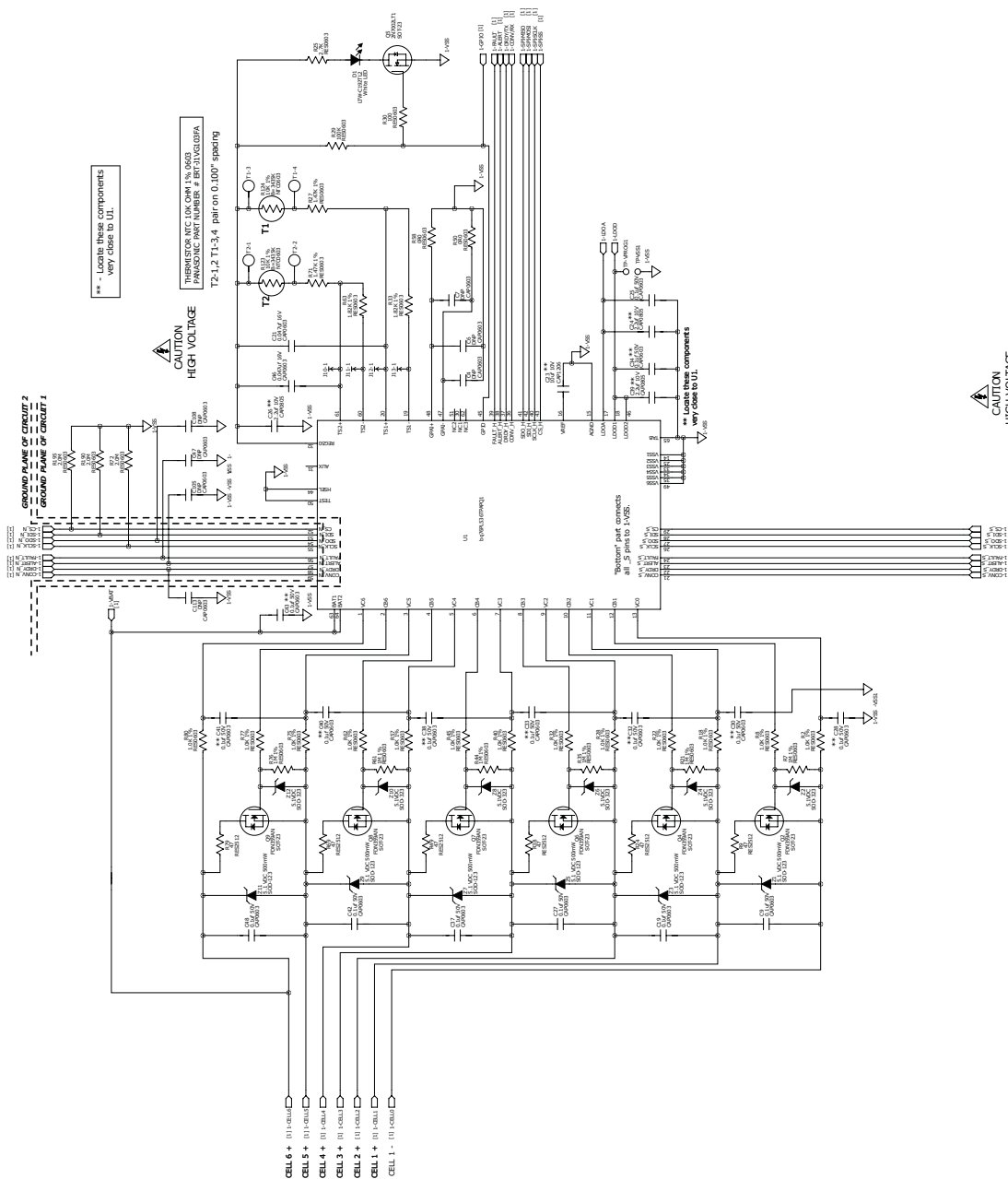

Figure 17. Schematic (Page 2 of 4)

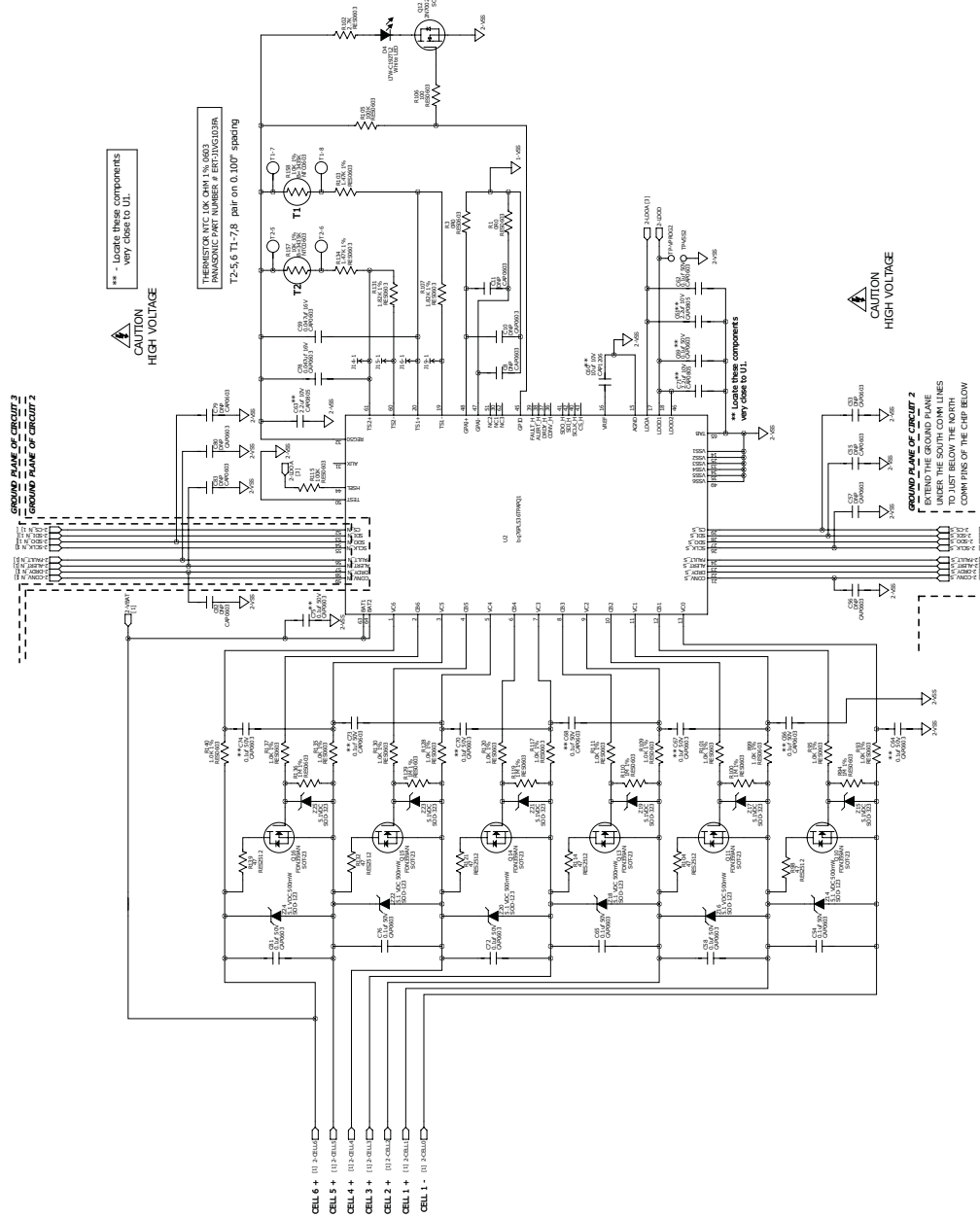

Figure 18. Schematic (Page 3 of 4)

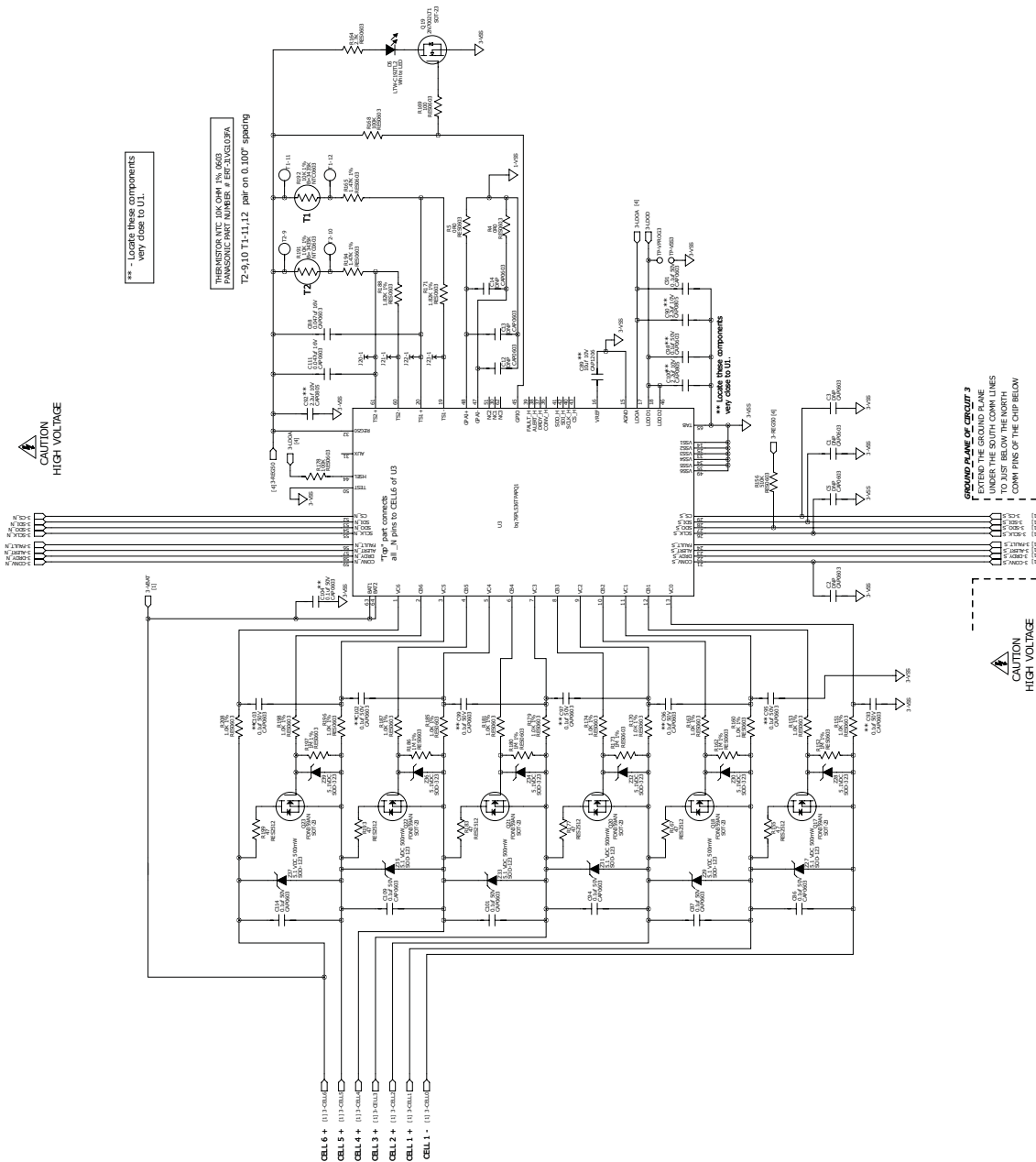

Figure 19. Schematic (Page 4 of 4)

Full size reference schematics are available from TI upon request.

---

**REVISION HISTORY**

<b>Changes from Original (December 2009) to Revision A</b>	<b>Page</b>
• Added and changed Bulleted list in Features, replaced description text, added Figure 1, Pin Descriptions and replaced the Functional Block Diagram .....	<b>1</b>
• Added New text and tables from the Absolute Max table to end of document .....	<b>6</b>

---

**PACKAGING INFORMATION**

Orderable Device	Status <sup>(1)</sup>	Package Type	Package Drawing	Pins	Package Qty	Eco Plan <sup>(2)</sup>	Lead/ Ball Finish	MSL Peak Temp <sup>(3)</sup>	Samples (Requires Login)
BQ76PL536PAPR	NRND	HTQFP	PAP	64	1000	Green (RoHS & no Sb/Br)	CU NIPDAU	Level-3-260C-168 HR	
BQ76PL536PAPT	NRND	HTQFP	PAP	64	250	Green (RoHS & no Sb/Br)	CU NIPDAU	Level-3-260C-168 HR	

<sup>(1)</sup> The marketing status values are defined as follows:

**ACTIVE:** Product device recommended for new designs.

**LIFEBUY:** TI has announced that the device will be discontinued, and a lifetime-buy period is in effect.

**NRND:** Not recommended for new designs. Device is in production to support existing customers, but TI does not recommend using this part in a new design.

**PREVIEW:** Device has been announced but is not in production. Samples may or may not be available.

**OBsolete:** TI has discontinued the production of the device.

<sup>(2)</sup> Eco Plan - The planned eco-friendly classification: Pb-Free (RoHS), Pb-Free (RoHS Exempt), or Green (RoHS & no Sb/Br) - please check <http://www.ti.com/productcontent> for the latest availability information and additional product content details.

**TBD:** The Pb-Free/Green conversion plan has not been defined.

**Pb-Free (RoHS):** TI's terms "Lead-Free" or "Pb-Free" mean semiconductor products that are compatible with the current RoHS requirements for all 6 substances, including the requirement that lead not exceed 0.1% by weight in homogeneous materials. Where designed to be soldered at high temperatures, TI Pb-Free products are suitable for use in specified lead-free processes.

**Pb-Free (RoHS Exempt):** This component has a RoHS exemption for either 1) lead-based flip-chip solder bumps used between the die and package, or 2) lead-based die adhesive used between the die and leadframe. The component is otherwise considered Pb-Free (RoHS compatible) as defined above.

**Green (RoHS & no Sb/Br):** TI defines "Green" to mean Pb-Free (RoHS compatible), and free of Bromine (Br) and Antimony (Sb) based flame retardants (Br or Sb do not exceed 0.1% by weight in homogeneous material)

<sup>(3)</sup> MSL, Peak Temp. -- The Moisture Sensitivity Level rating according to the JEDEC industry standard classifications, and peak solder temperature.

**Important Information and Disclaimer:** The information provided on this page represents TI's knowledge and belief as of the date that it is provided. TI bases its knowledge and belief on information provided by third parties, and makes no representation or warranty as to the accuracy of such information. Efforts are underway to better integrate information from third parties. TI has taken and continues to take reasonable steps to provide representative and accurate information but may not have conducted destructive testing or chemical analysis on incoming materials and chemicals. TI and TI suppliers consider certain information to be proprietary, and thus CAS numbers and other limited information may not be available for release.

In no event shall TI's liability arising out of such information exceed the total purchase price of the TI part(s) at issue in this document sold by TI to Customer on an annual basis.

**OTHER QUALIFIED VERSIONS OF BQ76PL536 :**

- Automotive: [BQ76PL536-Q1](#)

NOTE: Qualified Version Definitions:

- Automotive - Q100 devices qualified for high-reliability automotive applications targeting zero defects

**TAPE AND REEL INFORMATION**

**REEL DIMENSIONS**



**TAPE DIMENSIONS**



A0	Dimension designed to accommodate the component width
B0	Dimension designed to accommodate the component length
K0	Dimension designed to accommodate the component thickness
W	Overall width of the carrier tape
P1	Pitch between successive cavity centers

**TAPE AND REEL INFORMATION**

\*All dimensions are nominal

Device	Package Type	Package Drawing	Pins	SPQ	Reel Diameter (mm)	Reel Width W1 (mm)	A0 (mm)	B0 (mm)	K0 (mm)	P1 (mm)	W (mm)	Pin1 Quadrant
BQ76PL536PAPR	HTQFP	PAP	64	1000	330.0	24.4	13.0	13.0	1.5	16.0	24.0	Q2
BQ76PL536PAPT	HTQFP	PAP	64	250	330.0	24.4	13.0	13.0	1.5	16.0	24.0	Q2



**TAPE AND REEL BOX DIMENSIONS**

\*All dimensions are nominal

Device	Package Type	Package Drawing	Pins	SPQ	Length (mm)	Width (mm)	Height (mm)
BQ76PL536PAPR	HTQFP	PAP	64	1000	367.0	367.0	45.0
BQ76PL536PAPT	HTQFP	PAP	64	250	367.0	367.0	45.0

PAP (S-PQFP-G64)

PowerPAD™ PLASTIC QUAD FLATPACK



- NOTES:
- A. All linear dimensions are in millimeters.
  - B. This drawing is subject to change without notice.
  - C. Body dimensions do not include mold flash or protrusion
  - D. This package is designed to be soldered to a thermal pad on the board. Refer to Technical Brief, PowerPad Thermally Enhanced Package, Texas Instruments Literature No. SLMA002 for information regarding recommended board layout. This document is available at [www.ti.com](http://www.ti.com) <<http://www.ti.com>>.
  - E. Falls within JEDEC MS-026

PowerPAD is a trademark of Texas Instruments.

## THERMAL PAD MECHANICAL DATA

PAP (S-PQFP-G64)

PowerPAD™ PLASTIC QUAD FLATPACK

### THERMAL INFORMATION

This PowerPAD™ package incorporates an exposed thermal pad that is designed to be attached to a printed circuit board (PCB). The thermal pad must be soldered directly to the PCB. After soldering, the PCB can be used as a heatsink. In addition, through the use of thermal vias, the thermal pad can be attached directly to the appropriate copper plane shown in the electrical schematic for the device, or alternatively, can be attached to a special heatsink structure designed into the PCB. This design optimizes the heat transfer from the integrated circuit (IC).

For additional information on the PowerPAD package and how to take advantage of its heat dissipating abilities, refer to Technical Brief, PowerPAD Thermally Enhanced Package, Texas Instruments Literature No. SLMA002 and Application Brief, PowerPAD Made Easy, Texas Instruments Literature No. SLMA004. Both documents are available at [www.ti.com](http://www.ti.com).

The exposed thermal pad dimensions for this package are shown in the following illustration.

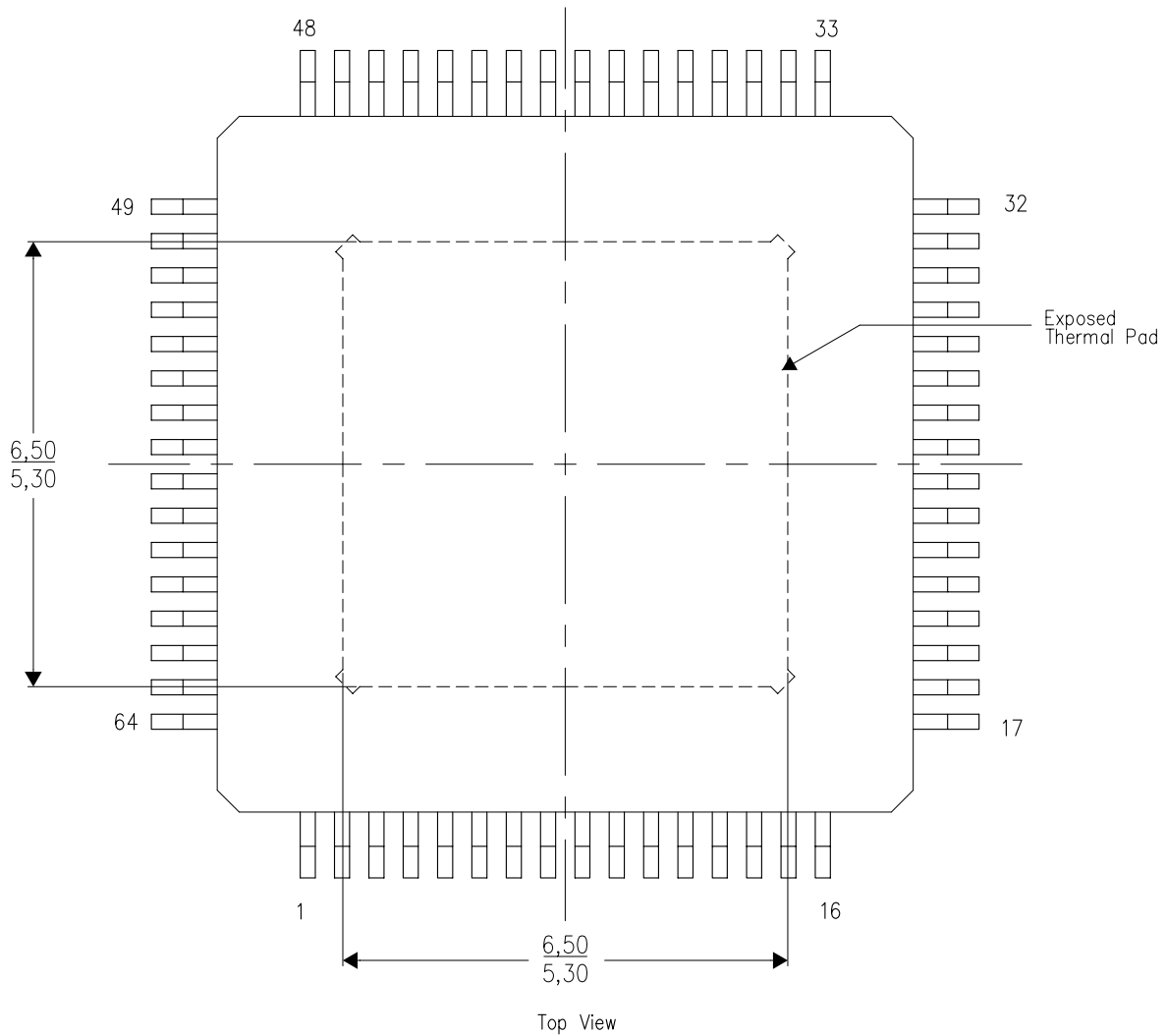

Exposed Thermal Pad Dimensions

4206326-4/M 09/10

NOTES: A. All linear dimensions are in millimeters

PowerPAD is a trademark of Texas Instruments

PAP (S-PQFP-G64)

PowerPAD™ PLASTIC QUAD FLATPACK

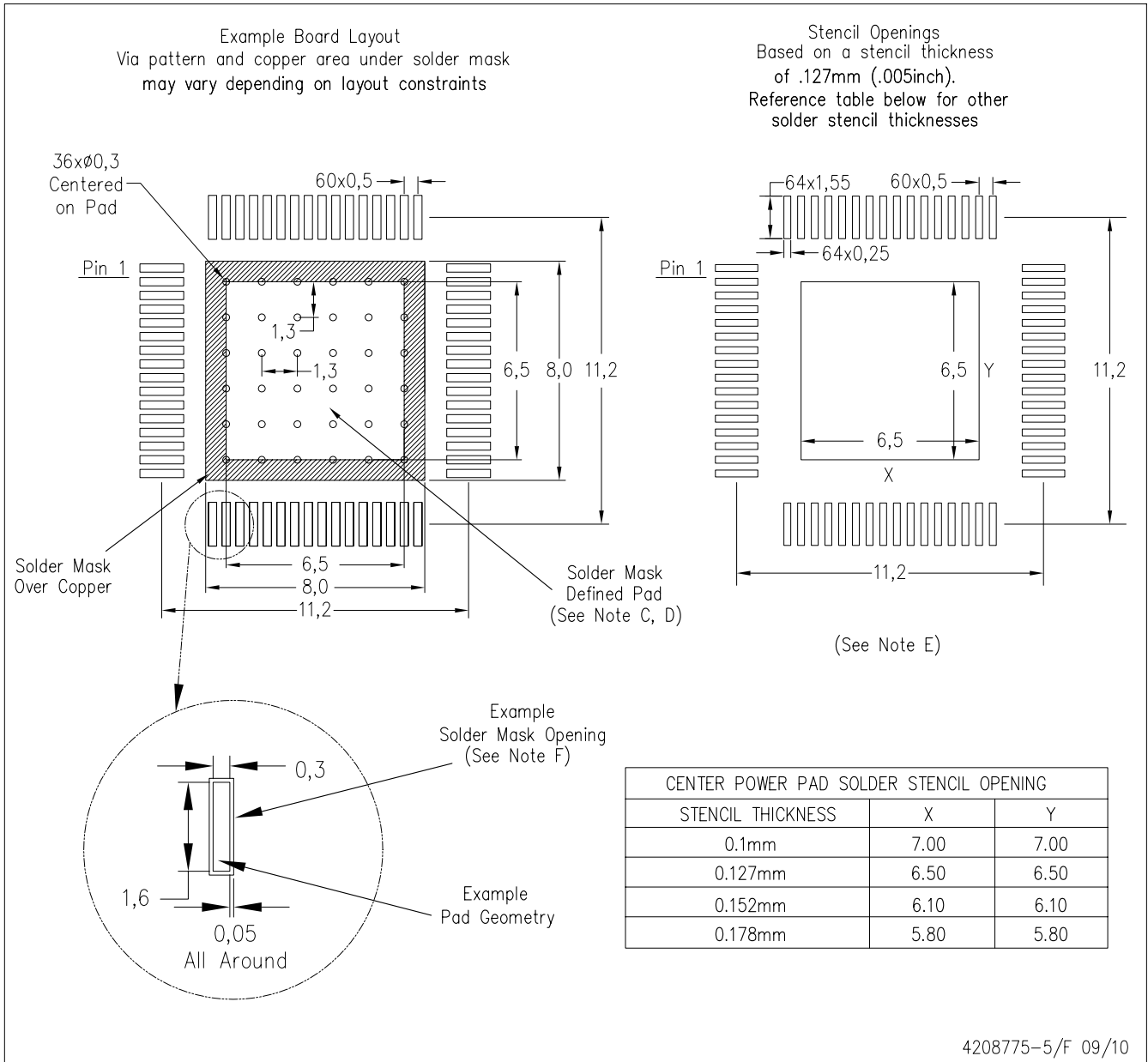

- NOTES:
- A. All linear dimensions are in millimeters.
  - B. This drawing is subject to change without notice.
  - C. Customers should place a note on the circuit board fabrication drawing not to alter the center solder mask defined pad.
  - D. This package is designed to be soldered to a thermal pad on the board. Refer to Technical Brief, PowerPAD Thermally Enhanced Package, Texas Instruments Literature No. SLMA002, SLMA004, and also the Product Data Sheets for specific thermal information, via requirements, and recommended board layout. These documents are available at [www.ti.com](http://www.ti.com) <<http://www.ti.com>>. Publication IPC-7351 is recommended for alternate designs.
  - E. Laser cutting apertures with trapezoidal walls and also rounding corners will offer better paste release. Customers should contact their board assembly site for stencil design recommendations. Example stencil design based on a 50% volumetric metal load solder paste. Refer to IPC-7525 for other stencil recommendations.
  - F. Customers should contact their board fabrication site for solder mask tolerances between and around signal pads.

PowerPAD is a trademark of Texas Instruments

## IMPORTANT NOTICE

Texas Instruments Incorporated and its subsidiaries (TI) reserve the right to make corrections, enhancements, improvements and other changes to its semiconductor products and services per JESD46, latest issue, and to discontinue any product or service per JESD48, latest issue. Buyers should obtain the latest relevant information before placing orders and should verify that such information is current and complete. All semiconductor products (also referred to herein as "components") are sold subject to TI's terms and conditions of sale supplied at the time of order acknowledgment.

TI warrants performance of its components to the specifications applicable at the time of sale, in accordance with the warranty in TI's terms and conditions of sale of semiconductor products. Testing and other quality control techniques are used to the extent TI deems necessary to support this warranty. Except where mandated by applicable law, testing of all parameters of each component is not necessarily performed.

TI assumes no liability for applications assistance or the design of Buyers' products. Buyers are responsible for their products and applications using TI components. To minimize the risks associated with Buyers' products and applications, Buyers should provide adequate design and operating safeguards.

TI does not warrant or represent that any license, either express or implied, is granted under any patent right, copyright, mask work right, or other intellectual property right relating to any combination, machine, or process in which TI components or services are used. Information published by TI regarding third-party products or services does not constitute a license to use such products or services or a warranty or endorsement thereof. Use of such information may require a license from a third party under the patents or other intellectual property of the third party, or a license from TI under the patents or other intellectual property of TI.

Reproduction of significant portions of TI information in TI data books or data sheets is permissible only if reproduction is without alteration and is accompanied by all associated warranties, conditions, limitations, and notices. TI is not responsible or liable for such altered documentation. Information of third parties may be subject to additional restrictions.

Resale of TI components or services with statements different from or beyond the parameters stated by TI for that component or service voids all express and any implied warranties for the associated TI component or service and is an unfair and deceptive business practice. TI is not responsible or liable for any such statements.

Buyer acknowledges and agrees that it is solely responsible for compliance with all legal, regulatory and safety-related requirements concerning its products, and any use of TI components in its applications, notwithstanding any applications-related information or support that may be provided by TI. Buyer represents and agrees that it has all the necessary expertise to create and implement safeguards which anticipate dangerous consequences of failures, monitor failures and their consequences, lessen the likelihood of failures that might cause harm and take appropriate remedial actions. Buyer will fully indemnify TI and its representatives against any damages arising out of the use of any TI components in safety-critical applications.

In some cases, TI components may be promoted specifically to facilitate safety-related applications. With such components, TI's goal is to help enable customers to design and create their own end-product solutions that meet applicable functional safety standards and requirements. Nonetheless, such components are subject to these terms.

No TI components are authorized for use in FDA Class III (or similar life-critical medical equipment) unless authorized officers of the parties have executed a special agreement specifically governing such use.

Only those TI components which TI has specifically designated as military grade or "enhanced plastic" are designed and intended for use in military/aerospace applications or environments. Buyer acknowledges and agrees that any military or aerospace use of TI components which have **not** been so designated is solely at the Buyer's risk, and that Buyer is solely responsible for compliance with all legal and regulatory requirements in connection with such use.

TI has specifically designated certain components which meet ISO/TS16949 requirements, mainly for automotive use. Components which have not been so designated are neither designed nor intended for automotive use; and TI will not be responsible for any failure of such components to meet such requirements.

### Products

Audio	<a href="http://www.ti.com/audio">www.ti.com/audio</a>
Amplifiers	<a href="http://amplifier.ti.com">amplifier.ti.com</a>
Data Converters	<a href="http://dataconverter.ti.com">dataconverter.ti.com</a>
DLP® Products	<a href="http://www.dlp.com">www.dlp.com</a>
DSP	<a href="http://dsp.ti.com">dsp.ti.com</a>
Clocks and Timers	<a href="http://www.ti.com/clocks">www.ti.com/clocks</a>
Interface	<a href="http://interface.ti.com">interface.ti.com</a>
Logic	<a href="http://logic.ti.com">logic.ti.com</a>
Power Mgmt	<a href="http://power.ti.com">power.ti.com</a>
Microcontrollers	<a href="http://microcontroller.ti.com">microcontroller.ti.com</a>
RFID	<a href="http://www.ti-rfid.com">www.ti-rfid.com</a>
OMAP Applications Processors	<a href="http://www.ti.com/omap">www.ti.com/omap</a>
Wireless Connectivity	<a href="http://www.ti.com/wirelessconnectivity">www.ti.com/wirelessconnectivity</a>

### Applications

Automotive and Transportation	<a href="http://www.ti.com/automotive">www.ti.com/automotive</a>
Communications and Telecom	<a href="http://www.ti.com/communications">www.ti.com/communications</a>
Computers and Peripherals	<a href="http://www.ti.com/computers">www.ti.com/computers</a>
Consumer Electronics	<a href="http://www.ti.com/consumer-apps">www.ti.com/consumer-apps</a>
Energy and Lighting	<a href="http://www.ti.com/energy">www.ti.com/energy</a>
Industrial	<a href="http://www.ti.com/industrial">www.ti.com/industrial</a>
Medical	<a href="http://www.ti.com/medical">www.ti.com/medical</a>
Security	<a href="http://www.ti.com/security">www.ti.com/security</a>
Space, Avionics and Defense	<a href="http://www.ti.com/space-avionics-defense">www.ti.com/space-avionics-defense</a>
Video and Imaging	<a href="http://www.ti.com/video">www.ti.com/video</a>

### TI E2E Community

[e2e.ti.com](http://e2e.ti.com)

# AMEYA360

## Components Supply Platform

Authorized Distribution Brand :



Website :

Welcome to visit [www.ameya360.com](http://www.ameya360.com)

Contact Us :

➤ Address :

401 Building No.5, JiuGe Business Center, Lane 2301, Yishan Rd  
Minhang District, Shanghai , China

➤ Sales :

Direct +86 (21) 6401-6692

Email [amall@ameya360.com](mailto:amall@ameya360.com)

QQ 800077892

Skype [ameyasales1](#) [ameyasales2](#)

➤ Customer Service :

Email [service@ameya360.com](mailto:service@ameya360.com)

➤ Partnership :

Tel +86 (21) 64016692-8333

Email [mkt@ameya360.com](mailto:mkt@ameya360.com)