

ASMT-SWB5-Nxxxx

Surface Mount LED Indicator

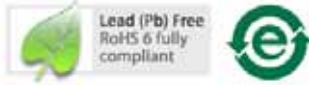

Data Sheet



Description

Avago Power PLCC-4 is an extension of our PLCC-2 SMT LEDs. The package can be driven at higher current due to its superior package design. The product is able to dissipate heat more efficiently compared to the conventional PLCC-2 SMT LEDs. In proportion to the increase in driving current, this family of LEDs is able to produce higher light output compared to the conventional PLCC-2 SMT LEDs.

These SMT LEDs have higher reliability and better performance and are designed to work under a wide range of environmental conditions. This higher reliability makes them suitable for use under harsh environment and conditions like automotive. In addition, they are also suitable to be used in electronic signs and signals.

To facilitate easy pick and place assembly, the LEDs are packed in EIA-compliant tape and reel. Every reel will be shipped in single intensity and color bin, to provide close uniformity.

These LEDs are compatible with IR solder reflow process.

Features

- Industry standard PLCC-4
- High reliability LED package
- High brightness using InGaN dice technologies
- High optical efficiency
- Higher ambient temperature at the same current possible compared to PLCC-2
- Available in full selection of colors
- Super wide viewing angle at 120°
- Available in 8mm carrier tape on 7-inch reel
- Compatible with both IR and TTW soldering process
- Stable & Consistent performance with minimum degradation with Silicone Encapsulation
- JEDEC MSL 2a

Applications

- Interior automotive
 - Instrument panel backlighting
 - Central console backlighting
 - Cabin backlighting
- Electronic signs and signals
 - Interior full color sign
 - Variable message sign
- Office automation, home appliances, industrial equipment
 - Front panel backlighting
 - Push button backlighting
 - Display backlighting

CAUTION: ASMT-SWB5-Nxxxx LEDs are Class 1C ESD sensitive. Please observe appropriate precautions during handling and processing. Refer to Avago Application Note AN-1142 for additional details.

Package Dimensions

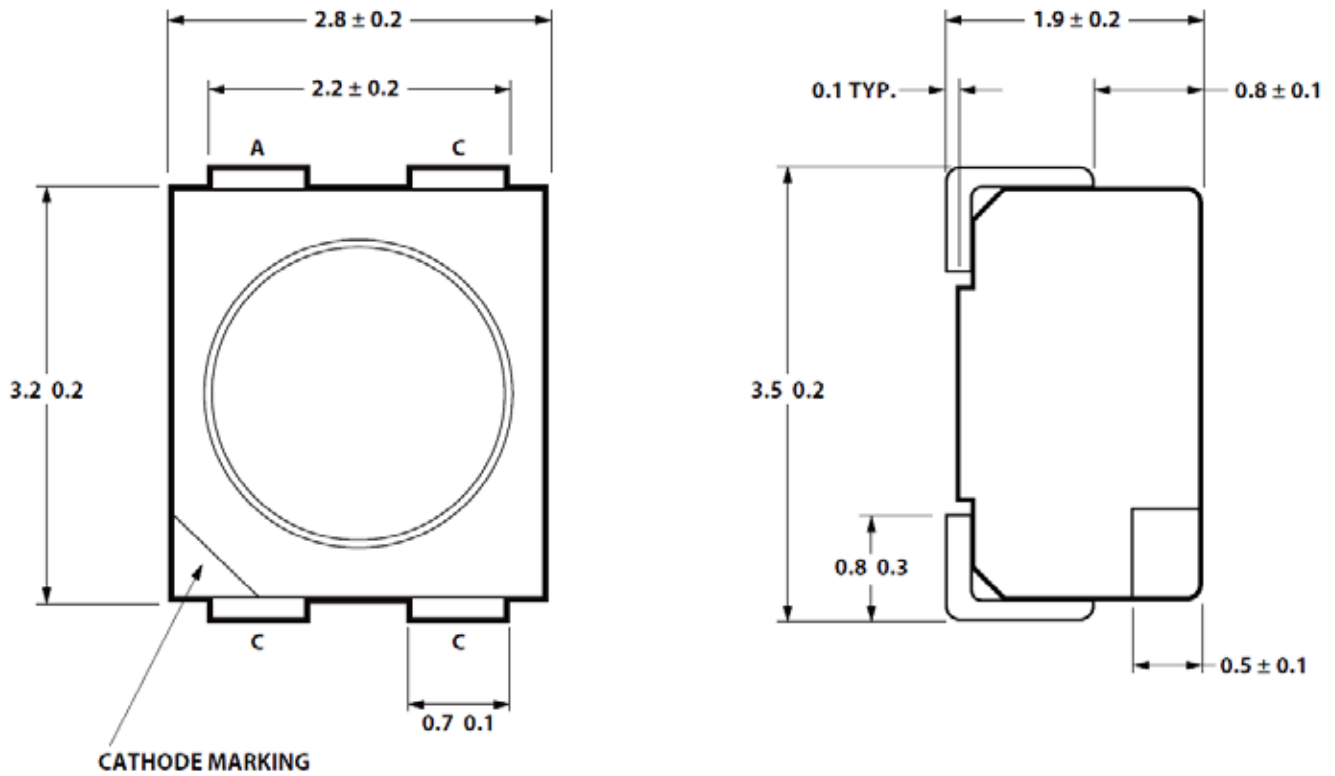

NOTE: ALL DIMENSIONS IN MILLIMETERS.
ELECTRICAL CONNECTION BETWEEN ALL CATHODES IS RECOMMENDED.

Table 1. Device Selection Guide

Color	Part Number	Min IV (mcd)	Max. IV (mcd)	Test Current (mA)	Dice Technology
White	ASMT-SWB5-NW703	1400.00	2850.00	30	InGaN

Notes:

1. The luminous intensity IV, is measured at the mechanical axis of the lamp package. The actual peak of the spatial radiation pattern may not be aligned with this axis.
2. IV Tolerance = $\pm 12\%$

Part Numbering System

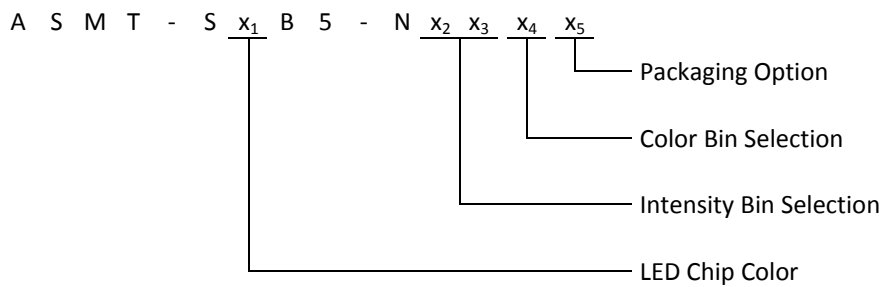

Table 2. Absolute Maximum Ratings (T_A = 25 °C)

Parameters	ASMT-SWB5
DC Forward Current ^[1]	30mA
Peak Forward Current ^[2]	90mA
Power Dissipation	114 mW
Reverse Voltage	5 V
Junction Temperature	110 °C
Operating Temperature	- 40 °C to + 100 °C
Storage Temperature	- 40 °C to + 100 °C

Notes:

1. Derate linearly as shown in Figure 4.
2. Duty Factor = 10%, Frequency = 1kHz.
3. Drive current between 10 mA and 20 mA is recommended for best long term performance.

Table 3. Optical Characteristics (T_A = 25 °C)

Color	Part Number	Dice Technology	Chromaticity Coordinates ^[3] Typ.		Viewing Angle 2θ _½ ^[2] (Degrees) Typ.
			x	y	
White	ASMT-SWB5	InGaN	0.318	0.318	120

Notes:

1. The chromaticity coordinates are derived from the CIE 1931 Chromaticity Diagram and represent the perceived color of the device.
2. θ_½ is the off-axis angle where the luminous intensity is ½ the peak intensity.
3. The chromaticity coordinates are derived from the CIE 1931 Chromaticity Diagram and represent the perceived color of the device.

Table 4. Electrical Characteristics (T_A = 25 °C)

Part Number	Forward Voltage V _F (Volts) @ I _F = 30 mA ^[1]		Reverse Voltage V _R @ 10μA Min.	Thermal Resistance Rθ _{JP} (°C/W)
	Typ.	Max.		
ASMT-SWB5	3.2	4.1	5	280

Notes:

1. Tolerance = ± 0.1V

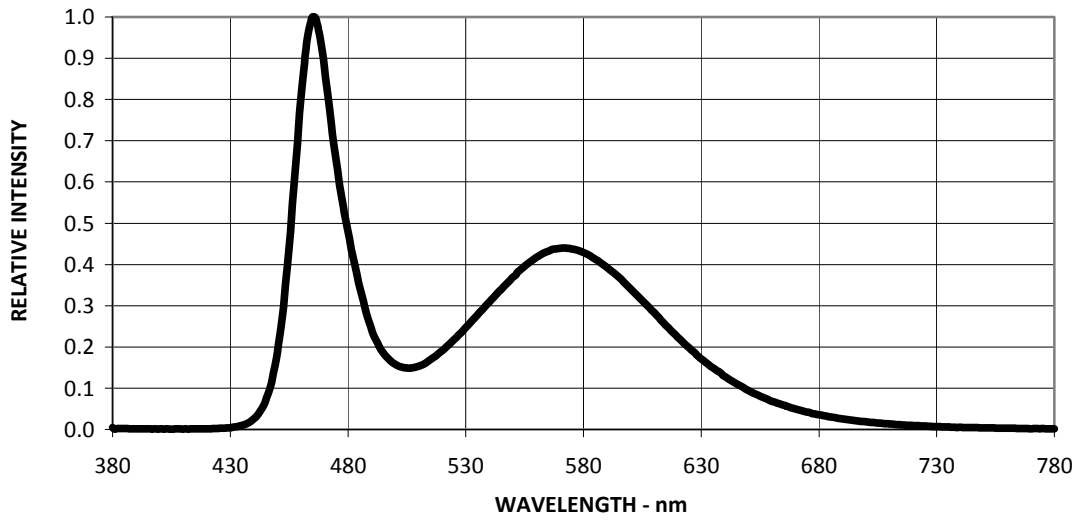

Figure 1. Relative Intensity Vs. Wavelength

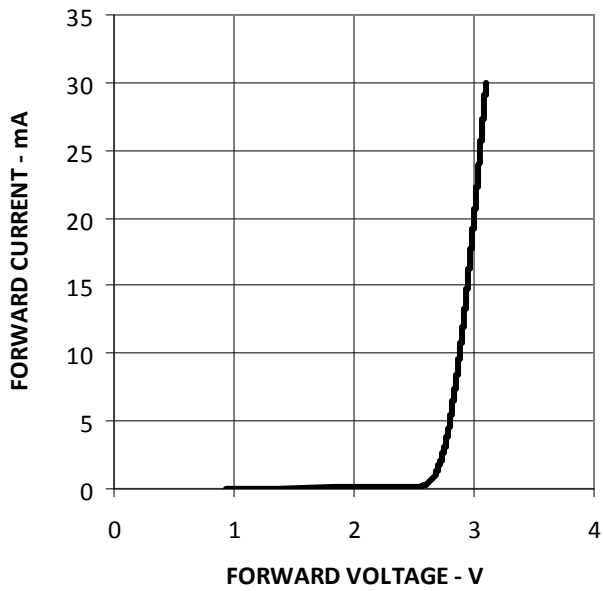

Figure 2. Forward Current Vs. Forward Voltage

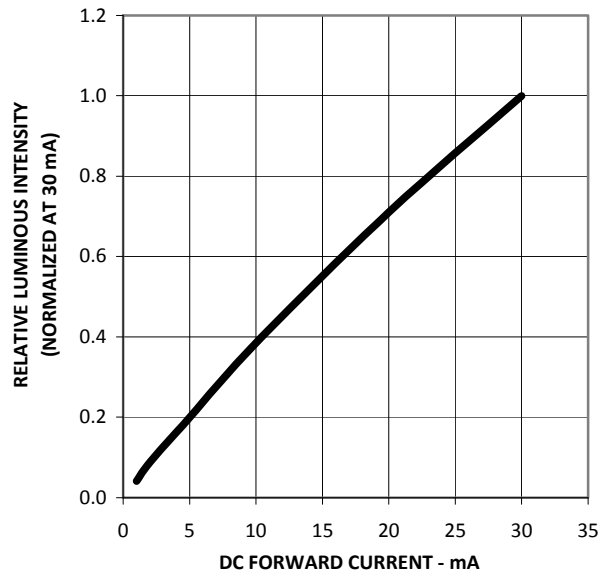

Figure 3. Relative Intensity Vs. Forward Current

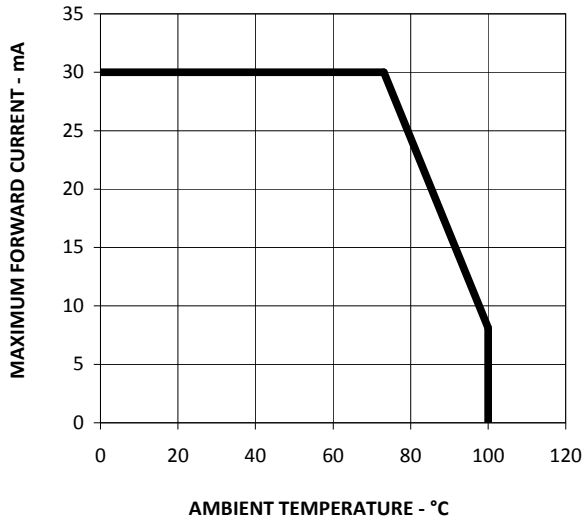

Figure 4. Maximum Forward Current Vs. Ambient Temperature. Derated Based on $T_{JMAX} = 110^{\circ}C$, $R_{\theta JA} = 300^{\circ}C/W$

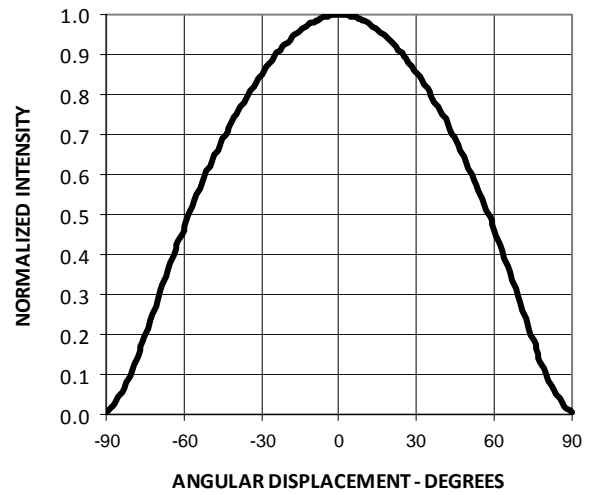
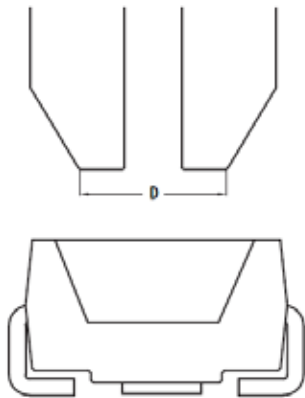
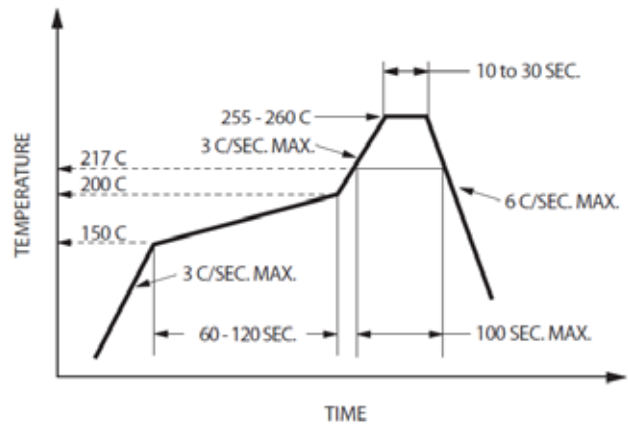

Figure 5. Radiation Pattern



Note: Diameter "D" should be smaller than 2.2mm SMT LED Indicator Components

Figure 6. Recommended Pick and Place Nozzle Size



Note: For detail information on reflow soldering of Avago surface mount LEDs, do refer to Avago Application Note AN 1060 Surface Mounting

Figure 7. Recommended Pb-free Reflow Soldering Profile

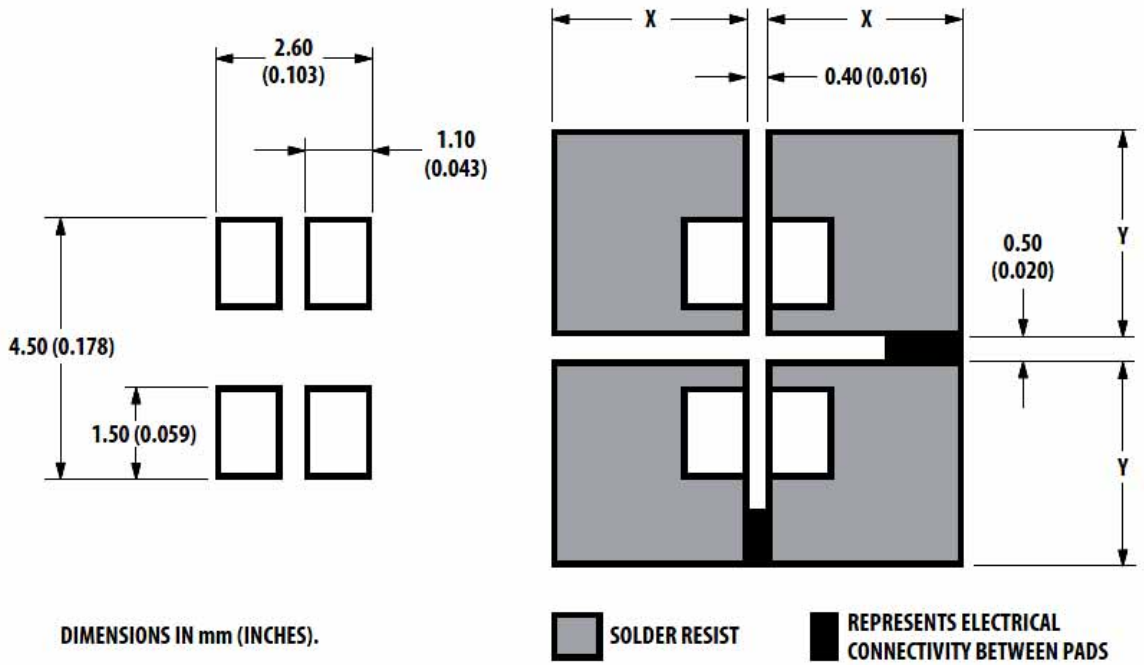

Figure 8. Recommended Soldering Pad Pattern

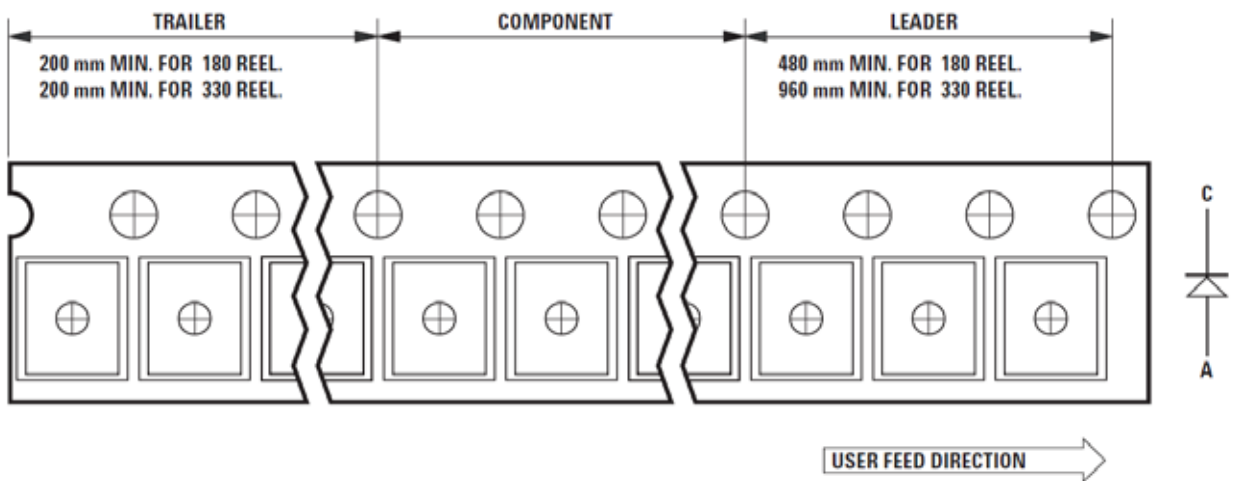

Figure 9. Tape Leader and Trailer Dimensions

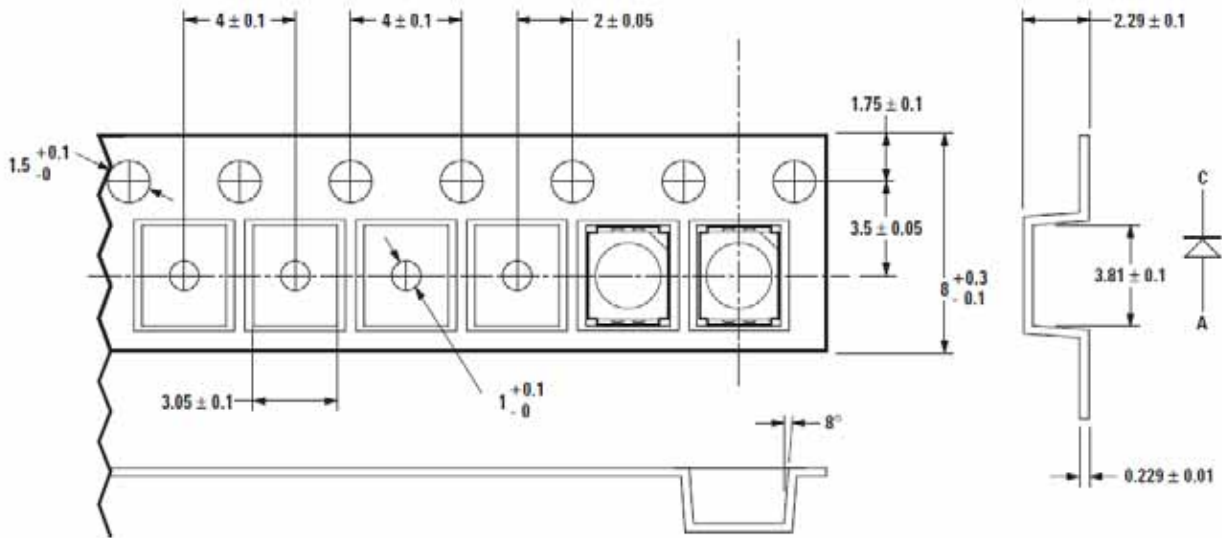

Figure 10. Tape Dimensions

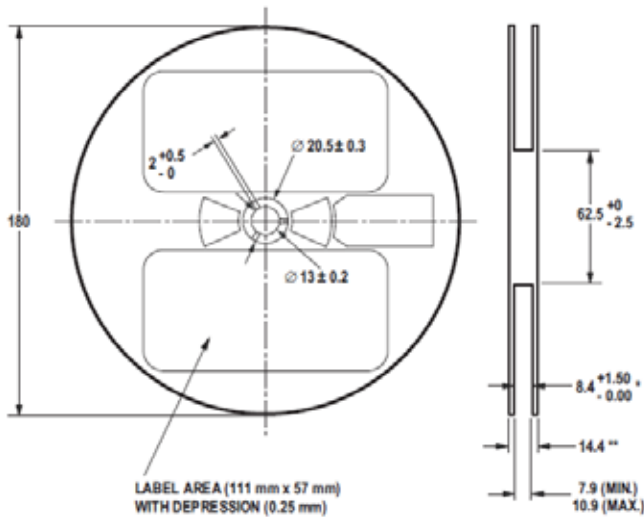

Figure 11. Reel dimensions

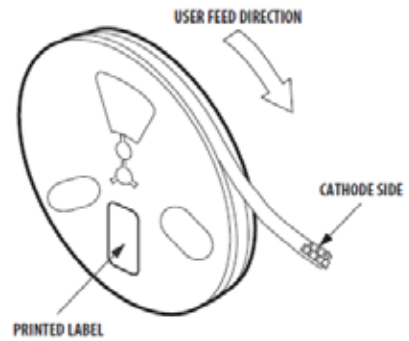

Figure 12. Reeling Orientation

Handling Precaution

The encapsulation material of the product is made of silicone for better reliability of the product. As silicone is a soft material, please do not press on the silicone or poke a sharp object onto the silicone. These might damage the product and cause premature failure. During assembly or handling, the unit should be held on the body only. Please refer to Avago Application Note AN 5288 for detail information.

Moisture Sensitivity

This product is qualified as Moisture Sensitive Level 2a per Jedec J-STD-020. Precautions when handling this moisture sensitive product is important to ensure the reliability of the product. Do refer to Avago Application Note AN5305 Handling of Moisture Sensitive Surface Mount Devices for details.

A. Storage before use

- Unopen moisture barrier bag (MBB) can be stored at <math> < 40^{\circ}\text{C} / 90\% \text{RH}</math> for 12 months. If the actual shelf life has exceeded 12 months and the HIC indicates that baking is not required, then it is safe to reflow the LEDs per the original MSL rating.
- It is not recommended to open the MBB prior to assembly (e.g. for IQC).

B. Control after opening the MBB

- The humidity indicator card (HIC) shall be read immediately upon opening of MBB.
- The LEDs must be kept at <math> < 30^{\circ}\text{C} / 60\% \text{RH}</math> at all time and all high temperature related process including soldering, curing or rework need to be completed within 672 hours.

C. Control for unfinished reel

- For any unused LEDs, they need to be stored in sealed MBB with desiccant or desiccator at <math> < 5\% \text{RH}</math>.
-

D. Control of assembled boards

- If the PCB soldered with the LEDs is to be subjected to other high temperature processes, the PCB need to be stored in sealed MBB with desiccant or desiccator at <math> < 5\% \text{RH}</math> to ensure no LEDs have exceeded their floor life of 672 hours.

E. Baking is required if:

- The HIC indicator is not GREEN at 10% and is AZURE at 5%.
- The LEDs are exposed to condition of $> 30^{\circ}\text{C} / 60\% \text{RH}$ at any time.
- The LEDs floor life exceeded 672 hours.
- Recommended baking condition: $60 \pm 5^{\circ}\text{C}$ for 20 hours.

Intensity Bin Select (X₂X₃)

Individual reel will contain parts from one half bin only

X ₂	Min I _v Bin
<hr/>	
X ₃	
<hr/>	
0	Full Distribution
A	1 half bins starting from X ₂ 1
2	2 half bins starting from X ₂ 1
3	3 half bins starting from X ₂ 1
4	4 half bins starting from X ₂ 1
5	2 half bins starting from X ₂ 1
B	1 half bins starting from X ₂ 2
6	2 half bins starting from X ₂ 2
7	3 half bins starting from X ₂ 2
8	4 half bins starting from X ₂ 2
9	2 half bins starting from X ₂ 2

Intensity Bin Limits

Bin ID	Min. (mcd)	Max. (mcd)
V1	715.00	900.00
V2	900.00	1125.00
W1	1125.00	1400.00
W2	1400.00	1800.00
X1	1800.00	2240.00
X2	2240.00	2850.00
Y1	2850.00	3550.00
Y2	3550.00	4500.00
Z1	4500.00	5600.00
Z2	5600.00	7150.00

Tolerance of each bin limit = ± 12%

Color Bin Select (X₄) For ASMT-SWB5

Individual reel will contain parts from one sub bin only.

X ₄	
0	Full Distribution
A	5K and 5L only
B	6K and 6L only
C	7K and 7L only
D	8K and 8L only
E	5K and 6K only
F	5L and 6L only
G	6K and 7K only
H	6L and 7L only
J	7K and 8K only
K	7L and 8L only
L	5K, 5L, 6K and 6L only
M	6K, 6L, 7K and 7L only
N	7K, 7L, 8K and 8L only
Z	Special binning

Color Bin Limit

Bin ID	Limits (Chromaticity Coordinates)				
1	x	0.296	0.291	0.31	0.313
	y	0.259	0.268	0.297	0.284
2	x	0.291	0.285	0.307	0.31
	y	0.268	0.279	0.312	0.297
3	x	0.313	0.31	0.33	0.33
	y	0.284	0.297	0.33	0.31
4	x	0.31	0.307	0.33	0.33
	y	0.297	0.312	0.347	0.33
5	x	0.33	0.33	0.338	0.352
	y	0.31	0.33	0.342	0.344
6	x	0.33	0.33	0.347	0.345
	y	0.33	0.347	0.371	0.352
7	x	0.352	0.338	0.364	0.36
	y	0.344	0.342	0.38	0.357
8	x	0.345	0.347	0.367	0.364
	y	0.352	0.371	0.401	0.38

Tolerance of each bin limit = ± 0.02

Packaging Option (X₅)

Option	Test Current	Package Type	Reel Size
3	30mA	Top Mount	7 inch

Color Coordinate Chart

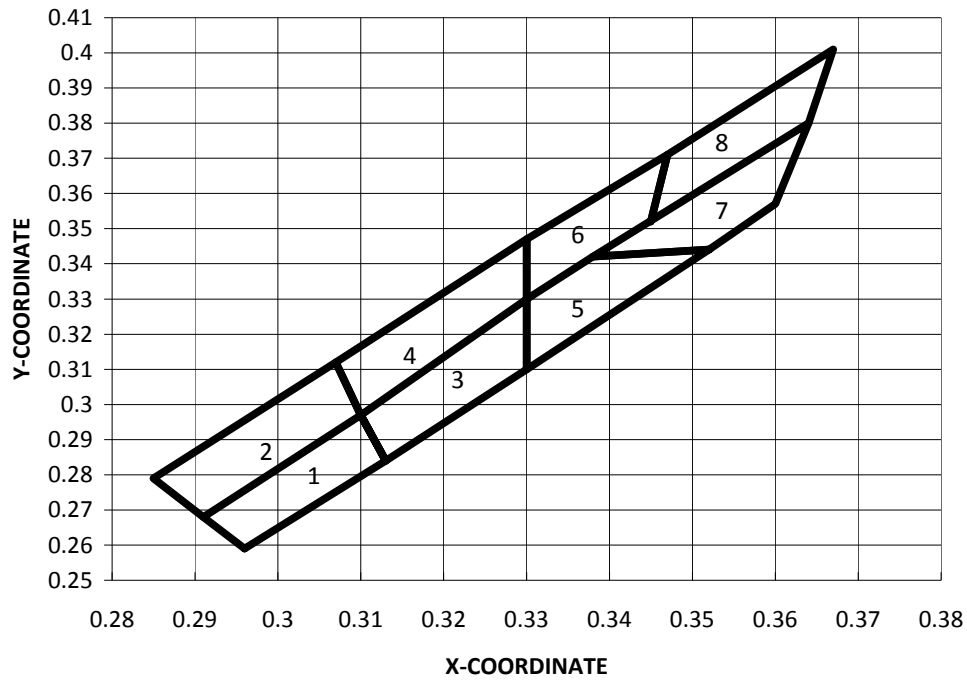

For product information and a complete list of distributors, please go to our web site:
www.avagotech.com

Avago, Avago Technologies, and the A logo are trademarks of Avago Technologies, Pte. in the United States and other countries.

Data subject to change. Copyright © 2005 Avago Technologies Pte. All rights reserved.
May 13, 2011



AMEYA360

Components Supply Platform

Authorized Distribution Brand :



Website :

Welcome to visit www.ameya360.com

Contact Us :

➤ Address :

401 Building No.5, JiuGe Business Center, Lane 2301, Yishan Rd
Minhang District, Shanghai , China

➤ Sales :

Direct +86 (21) 6401-6692

Email amall@ameya360.com

QQ 800077892

Skype [ameyasales1](#) [ameyasales2](#)

➤ Customer Service :

Email service@ameya360.com

➤ Partnership :

Tel +86 (21) 64016692-8333

Email mkt@ameya360.com