

PMH Panel Mount Power Supply

24V 50W 1 Phase / PMH-24V50WCA□

PMH

Highlights & Features

- Universal AC input voltage
- Full corrosion resistant aluminium chassis
- High MTBF > 700,000 hrs. as per Telcordia SR-332
- Designed for household appliances to IEC/EN 60335-1, IEC/EN 61558-1 and IEC/EN 61558-2-16
- Versatile connector options available: IP20, Front Face and Harness connectors

Safety Standards



CB Certified for worldwide use

Model Number: PMH-24V50WCA□
Unit Weight: 0.21 kg
Dimensions (H x W x D): 98 x 97 x 38 mm



General Description

The PMH-24V50WCA□ offers 24V output voltage and 50W output power. The PMH series is specifically designed for household electrical appliances with safety approvals including IEC/EN 60335-1 and IEC/EN 61558-2-16. The excellent design also meets the EMC approvals to EN 55014-1 and EN 55014-2 for household appliances without extra EMI filter required.

Model Information

PMH Panel Mount Power Supply

Model Number	Input Voltage Range	Output Voltage	Output Current
PMH-24V50WCA□	85-264Vac (120-375Vdc)	24Vdc	2.10A

Model Numbering

PM	H –	24V	50W	C	A	□
Panel Mount	Product Type H – Household Series	Output Voltage	Output Power	Package Type C – Enclosed	No PFC	Connector Type A – Terminal Block J – IP20 Connector* L – Front Face* H – Harness*

*Options

PMH Panel Mount Power Supply

24V 50W 1 Phase / PMH-24V50WCA□

Specifications

Input Ratings / Characteristics

Nominal Input Voltage	100-240Vac
Input Voltage Range	85-264Vac
Nominal Input Frequency	50-60Hz
Input Frequency Range	47-63Hz
Nominal DC Input Voltage	125-250Vdc
DC Input Voltage Range	120-375Vdc
Input Current	< 1.10A @ 115Vac, < 0.70A @ 230Vac
Efficiency at 100% Load	> 87.0% @ 115Vac, > 88.0% 230Vac
Max Inrush Current	< 35A @ 115Vac, < 70A @ 230Vac
Leakage Current	< 1mA @ 240Vac

Output Ratings / Characteristics

Nominal Output Voltage	24Vdc
Output Voltage Tolerance	± 2% (initial set point tolerance from factory)
Output Voltage Adjustment Range	22-28Vdc
Output Current	2.10A
Output Power	50W
Line Regulation	< 0.5% typ. (@ 85-264Vac input, 100% load)
Load Regulation	< 1% typ. (@ 85-264Vac input, 0-100% load)
PARD (20MHz)	< 150mVpp
Rise Time	< 30ms @ nominal input (100% load)
Start-up Time	< 2500ms @ nominal input (100% load)
Hold-up Time	> 15ms @ 115Vac, > 90ms @ 230Vac (100% load)
Dynamic Response (Overshoot & Undershoot O/P Voltage)	± 5% @ 0-100% load
Start-up with Capacitive Loads	8,000µF Max @ 25°C 4,000µF Max @ -20°C

PMH Panel Mount Power Supply

24V 50W 1 Phase / PMH-24V50WCA□

Mechanical

Case Chassis / Cover	Aluminium	
Dimensions (L x W x D)	98 x 97 x 38 mm	
Unit Weight	0.21 kg	
Indicator	Green LED (DC OK)	
Cooling System	Convection	
Terminal	PMH-24V50WCA <u>A</u>	M3.5 x 5 Pins (Rated 300V/15A)
	PMH-24V50WCA <u>J</u>	M3.5 x 5 Pins (Rated 300V/20A)
	PMH-24V50WCA <u>L</u>	M3.5 x 5 Pins (Rated 300V/20A)
	PMH-24V50WCA <u>H</u>	Input: B3P(6-2.3.5)-VH(LF)(SN) Output: B2P3-VH(LF)(SN)
Wire	PMH-24V50WCA <u>A</u>	AWG 20-14
	PMH-24V50WCA <u>J</u>	AWG 20-12
	PMH-24V50WCA <u>L</u>	
Noise (1 Meter from power supply)	Sound Pressure Level (SPL) < 40dBA	

Environment

Surrounding Air Temperature	Operating	-20°C to +70°C
	Storage	-25°C to +85°C
Power De-rating	> 50°C de-rate power by 2.5% / °C	
Operating Humidity	5 to 95% RH (Non-Condensing)	
Operating Altitude	0 to 5,000 Meters	
Shock Test (Non-Operating)	IEC 60068-2-27, 30G (300m/S ²) for a duration of 18ms, 1 times per direction, 2 times in total	
Vibration (Non-Operating)	IEC 60068-2-6, 10Hz to 150Hz @ 50m/S ² (5G peak); 20 min per axis for all X, Y, Z direction	
Pollution Degree	2	

Protections

Overvoltage	28.8-35.2V, SELV Output, Hiccup Mode, Non-Latching (Auto-Recovery)
Overload / Overcurrent	> 120% of rated load current, Hiccup Mode, Non-Latching (Auto recovery)
Over Temperature	< 75°C Ambient Temp@ 100% load, Non-Latching (Auto-recovery)
Short Circuit	Hiccup Mode, Non-Latching (Auto-recovery when the fault is removed).
Protection Against Shock	Class I with PE* connection

*PE: Primary Earth

PMH Panel Mount Power Supply

24V 50W 1 Phase / PMH-24V50WCA□

Reliability Data

MTBF	> 700,000 hrs, as per Telcordia SR-332 I/P: 115Vac, O/P: 100% load, Ta: 25°C
Expected Cap Life Time	10 years (115Vac & 230Vac, 50% load @ 40°C)

Safety Standards / Directives

Electrical Safety	SIQ Bauart UL/cUL recognized CB scheme	EN 60950-1, EN 60335-1, EN 61558-1, EN 61558-2-16 UL 60950-1 and CSA C22.2 No. 60950-1 IEC 60950-1, IEC 60335-1, IEC 61558-1, IEC 61558-2-16
CE		In conformance with EMC Directive 2004/108/EC and Low Voltage Directive 2006/95/EC
Material and Parts		RoHS Directive 2011/65/EU Compliant
Galvanic Isolation	Input to Output	5.0KVac
	Input to Ground	1.5KVac

EMC

EMC / Emissions		CISPR 22, EN 55022, FCC Title 47: Class B, EN 55014-1, EN 61000-6-3
Immunity to		EN 55024, EN 61000-6-1, EN 55014-2
Electrostatic Discharge	IEC 61000-4-2	Level 4 Criteria A ¹⁾ Air Discharge: 15kV Contact Discharge: 8kV
Radiated Field	IEC 61000-4-3	Level 3 Criteria A ¹⁾ 80MHz-1GHz, 10V/M with 1kHz tone / 80% modulation 1.4GHz-2GHz, 10V/M with 1kHz tone / 80% modulation 2GHz-2.7GHz, 10V/M with 1kHz tone / 80% modulation
Electrical Fast Transient / Burst	IEC 61000-4-4	Level 3 Criteria A ¹⁾ 2kV
Surge	IEC 61000-4-5	Level 3 Criteria A ¹⁾ Common Mode ²⁾ : 2kV Differential Mode ³⁾ : 1kV
Conducted	IEC 61000-4-6	Level 3 Criteria A ¹⁾ 150kHz-80MHz, 10Vrms
Power Frequency Magnetic Fields	IEC 61000-4-8	Criteria A ¹⁾ 10A/Meter
Voltage Dips	IEC 61000-4-11	100% dip; 1 cycle (20ms); Self Recoverable
Low Energy Pulse Test (Ring Wave)	IEC 61000-4-12	Level 3 Criteria A ¹⁾ Common Mode ²⁾ : 2kV Differential Mode ³⁾ : 1kV
Voltage Fluctuation and Flicker		IEC/EN 61000-3-3

1) Criteria A: Normal performance within the specification limits

2) Asymmetrical: Common mode (Line to earth)

3) Symmetrical: Differential mode (Line to line)

PMH Panel Mount Power Supply

24V 50W 1 Phase / PMH-24V50WCA□

Block Diagram

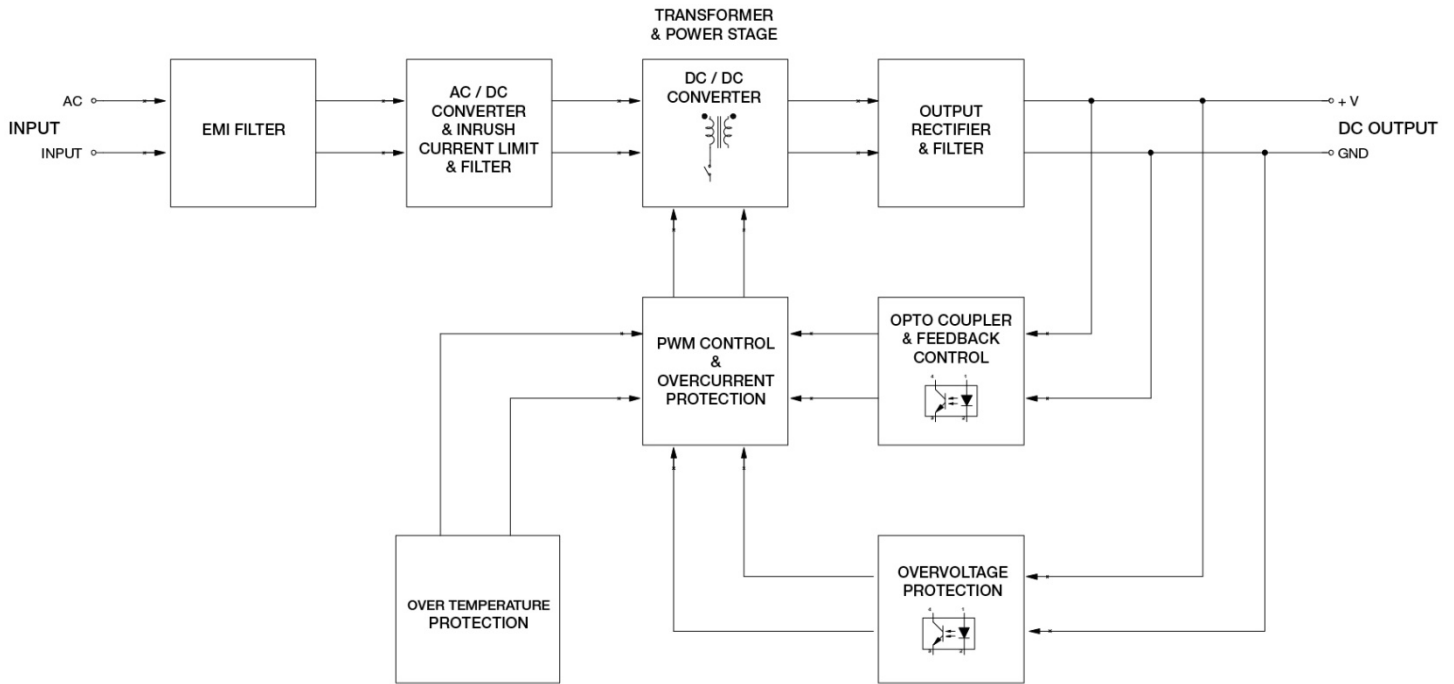

Device Descriptions

<p>PMH-24V50WCA□: Terminal Block</p>	<p>PMH-24V50WCA□: IP20 Terminal Block</p>
	<p>PMH-24V50WCA□: Front Face</p>
	<p>PMH-24V50WCA□: Harness</p>

- 1) Input & Output terminal block connector
- 2) DC voltage adjustment potentiometer (22V – 28V)
- 3) DC OK control LED (Green)

PMH Panel Mount Power Supply

24V 50W 1 Phase / PMH-24V50WCA□

Dimensions

L x W x D: 98 x 97 x 38 mm (PMH-24V50WCA□: Terminal Block)

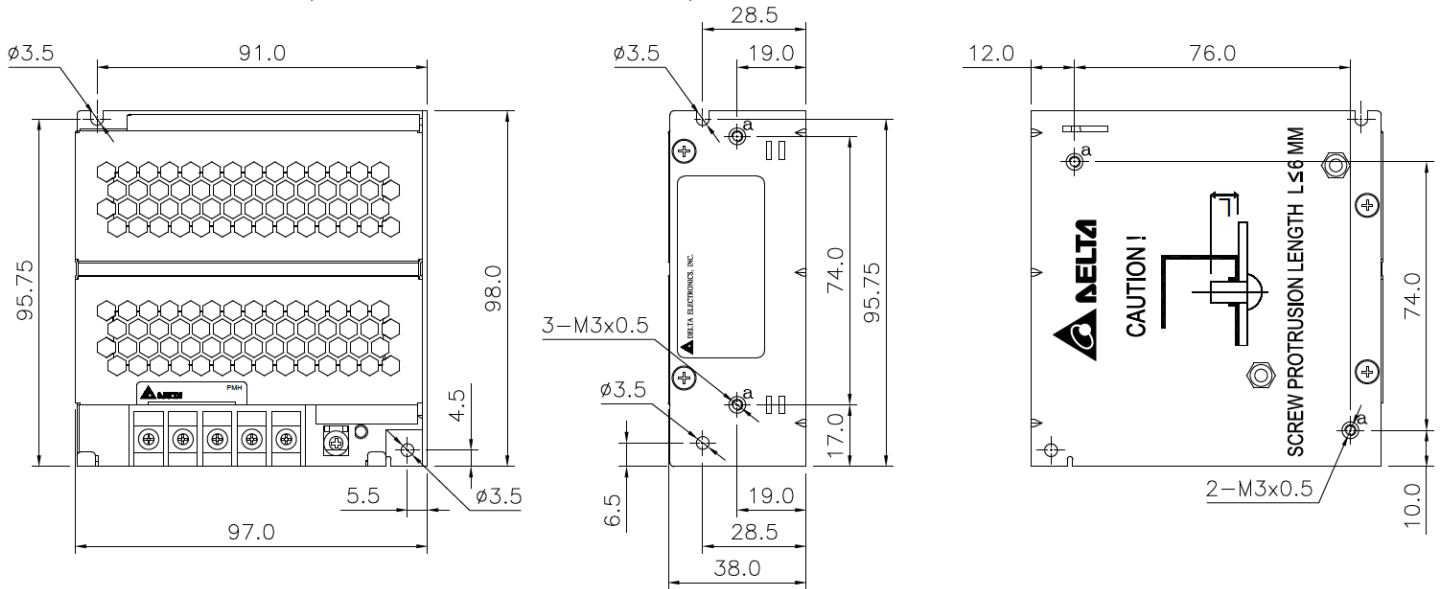

Engineering Data

De-rating

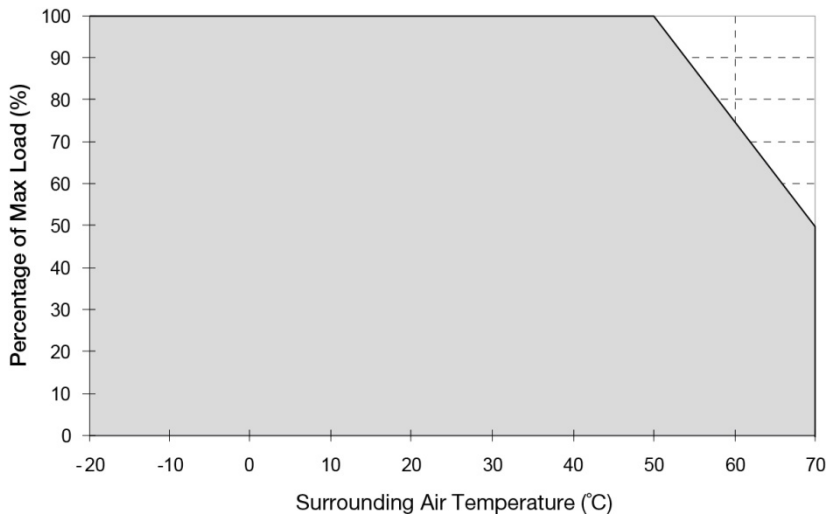

Fig. 1 De-rating for Vertical and Horizontal Mounting Orientation
 > 50°C de-rate power by 2.5% / °C

Note

1. Power supply components may degrade, or be damaged, when the power supply is continuously used outside the shaded region, refer to the graph shown in Fig. 1.
2. If the output capacity is not reduced when surrounding air temperature >50°C, the device will run into Over Temperature Protection. When activated, the output voltage will go into bouncing mode and will recover when the surrounding air temperature is lowered or the load is reduced as far as necessary to keep the device in working condition.
3. In order for the device to function in the manner intended, it is also necessary to keep a safety distance of 20mm with adjacent units while the device is in operation.
4. Depending on the surrounding air temperature and output load delivered by the power supply, the device can be very hot!
5. If the device has to be mounted in any other orientation, please do not hesitate to contact info@deltapsu.com for more details.

PMH Panel Mount Power Supply

24V 50W 1 Phase / PMH-24V50WCA□

Output De-rating VS. AC Input Voltage

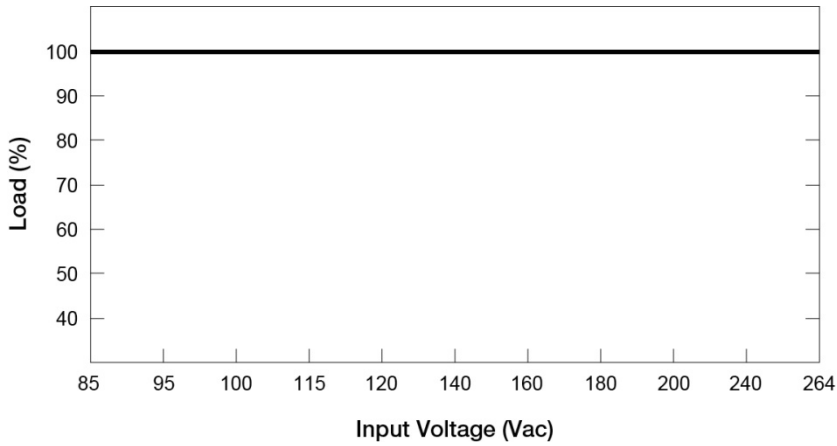

■ No output power de-rating across the entire input voltage range

Assembly & Installation

- Ⓐ Mounting holes for power supply assembly onto the mounting surface.
The power supply shall be mounted on minimum 2 mounting holes using M3 screw minimum 5mm length.
- Ⓑ This surface belongs to customer's end system or panel where the power supply is mounted.
- Ⓒ Connector

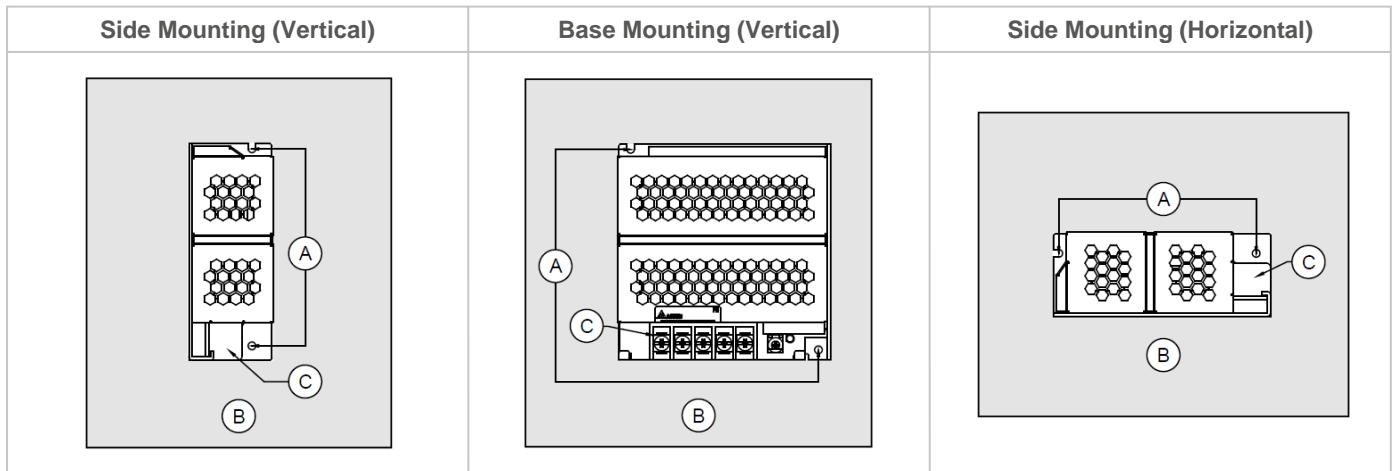

Fig. 2 Mounting Orientation

- Use flexible cable (stranded or solid) with the following sizes:

PMH-24V50WCAA	PMH-24V50WCAJ	PMH-24V50WCAL
AWG 20-14	AWG 20-12	AWG 20-12

- The torque at the Connector shall not exceed 13Kgf.cm. The insulation stripping length should not exceed 0.275" or 7mm.

PMH Panel Mount Power Supply

24V 50W 1 Phase / PMH-24V50WCA□

Installation of Mounting Accessories

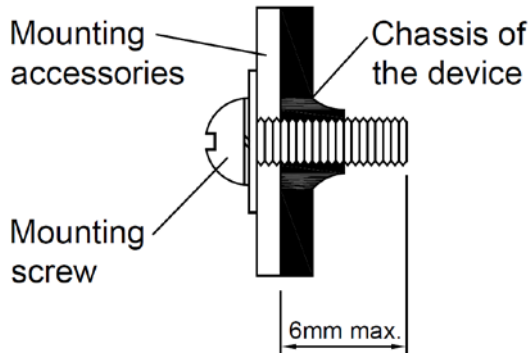

- Only use M3 screw $\leq 6\text{mm}$ through the base mounting holes. This is to keep a safety distance between the screw and internal components.
- Recommended mounting tightening torque: 4~8Kgf.cm.

Safety Instructions

- To ensure sufficient convection cooling, always maintain a safety distance of $\geq 20\text{mm}$ from all ventilated surfaces while the device is in operation.
- The device is not recommended to be placed on low thermal conductive surface, for example, plastics.
- Note that the enclosure of the device can become very hot depending on the ambient temperature and load of the power supply. Do not touch the device while it is in operation or immediately after power is turned OFF. Risk of burning!
- Do not touch the terminals while power is being supplied. Risk of electric shock.
- Prevent any foreign metal, particles or conductors from entering the device through the openings during installation. It may cause: Electric shock; Safety Hazard; Fire; Product failure
- The appliance is not to be used by persons (including children) with reduced physical, sensory or mental capabilities, or lack of experience and knowledge, unless they have been given supervision or instruction.
- Warning: When connecting the device, secure Earth connection before connecting L and N. When disconnecting the device, remove L and N connections before removing the Earth connection.
- The device is earthed and must be inaccessible.

PMH Panel Mount Power Supply

24V 50W 1 Phase / PMH-24V50WCA□

Functions

Start-up Time

The time required for the output voltage to reach 90% of its set value, after the input voltage is applied.

Rise Time

The time required for the output voltage to change from 10% to 90% of its set value.

Hold-up Time

Hold up time is the time when the AC input collapses and output voltage retains regulation for a certain period of time. The time required for the output to reach 95% of its set value, after the input voltage is removed.

■ Graph illustrating the Start-up Time, Rise Time, and Hold-up Time

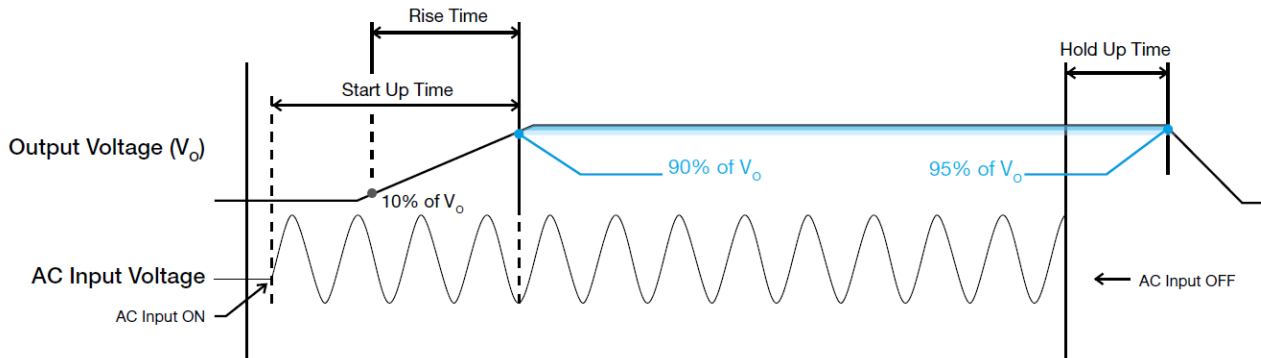

Inrush Current

Inrush current is the peak, instantaneous, input current measured and, occurs when the input voltage is first applied. For AC input voltages, the maximum peak value of inrush current will occur during the first half cycle of the applied AC voltage. This peak value decreases exponentially during subsequent cycles of AC voltage.

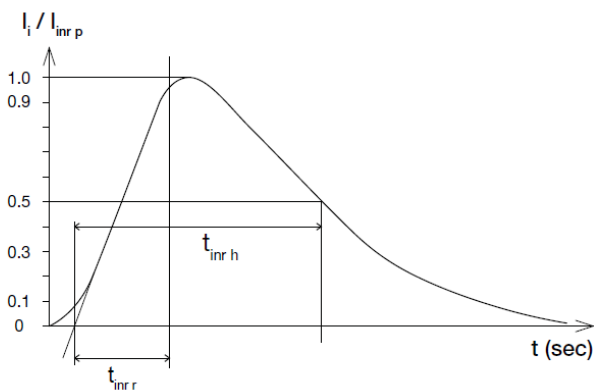

Dynamic Response

The power supply output voltage will remain within $\pm 5\%$ of its steady state value, when subjected to a dynamic load from 0% to 100% of its rated current.

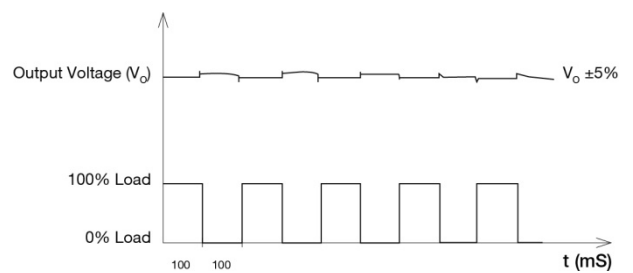

PMH Panel Mount Power Supply

24V 50W 1 Phase / PMH-24V50WCA□

Overload & Overcurrent Protections

The power supply's Overload (OLP) and Overcurrent (OCP) Protections will be activated when output current exceeds 120% of I_O (Max load). In such occurrence, the V_O will start to droop and once the power supply has reached its maximum power limit, the protection is activated and the power supply will go into "Hiccup mode" (Auto-Recovery). The power supply will recover once the fault condition of the OLP and OCP is removed and I_O is back within the specifications.

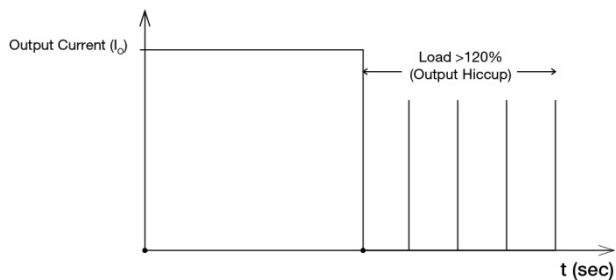

It is not recommended to prolong the duration of I_O when it is <120% but >100%, since it may cause damage to the PSU.

Short Circuit Protection

The power supply's output OLP/OCP function also provides protection against short circuits. When a short circuit is applied, the output current will operate in "Hiccup mode", as shown in the illustration in the OLP/OCP section on this page. The power supply will return to normal operation after the short circuit is removed.

Overvoltage Protection

The power supply's overvoltage circuit will be activated when its internal feedback circuit fails. The output voltage shall not exceed its specifications defined on Page 3 under "Protections".

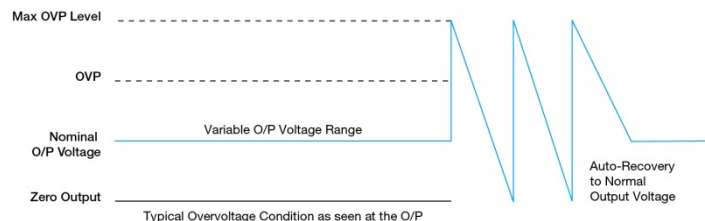

Over Temperature Protection

As mentioned above, the power supply also has Over Temperature Protection (OTP). In the event of a higher operating temperature at 100% load, the power supply will run into OTP when the operating temperature is beyond what is recommended in the de-rating graph. When activated, the output voltage will go into bouncing mode until the temperature drops to its normal operating temperature as recommended in the de-rating graph.

PMH Panel Mount Power Supply

24V 50W 1 Phase / PMH-24V50WCA□

Operating Mode

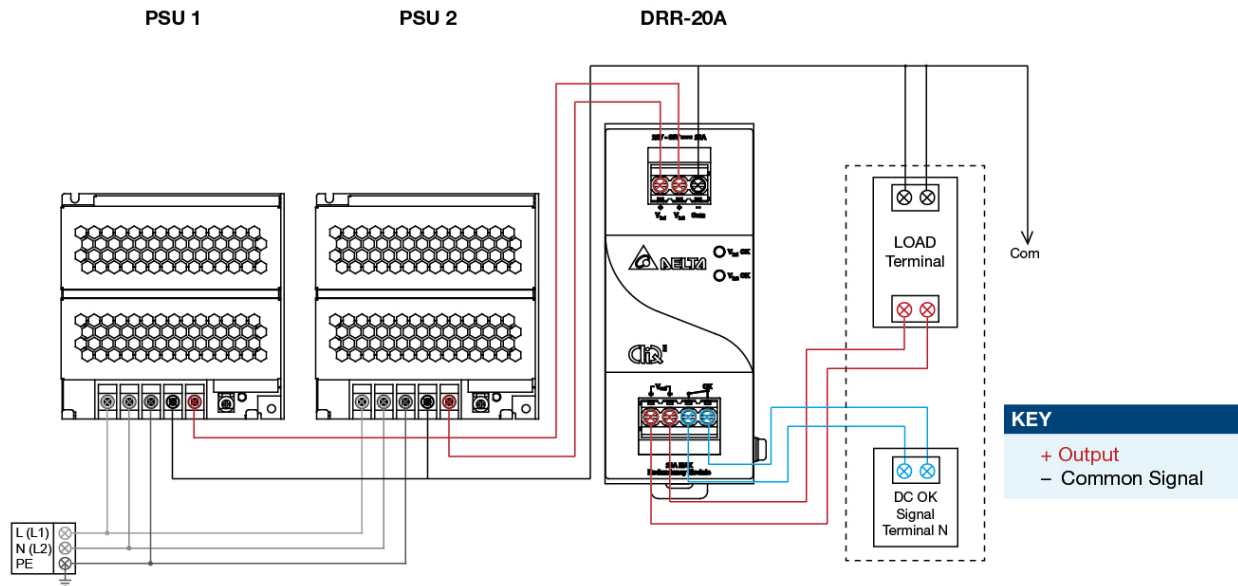

Fig. 3 Redundancy / Parallel Operation Connection Diagram

■ Redundancy Operation

In order to ensure proper redundancy operation for the power supply unit (PSU), ensure that the output voltage difference between the two units is kept at 0.45~0.50V for 24V supplies. Follow simple steps given below to verify:

Step 1.

Measure output voltage of PSU 1 and PSU 2. If PSU 1 is the master unit, then V_O of PSU 1 must be higher than PSU 2. In order to set the output voltage, connect the power supply to 50% load and set the PSU 1 and PSU 2 output voltage.

Step 2.

Connect the right DRR module, 20A as per the system requirement to the power supply units PSU 1 and PSU 2 at $V_{in 1}$ & $V_{in 2}$ respectively.

Step 3.

Connect the system load from V_{out} . Please note that output voltage V_{out} from DRR module will be = V_O (output voltage of power supply) - V_{drop}^* (in DRR module).

■ Parallel Operation

These DRR modules can also be used for Parallel function in order to increase the output power by N+1 (e.g. 2.5A + 2.5A = 5A or 2.5A + 2.5A + 2.5A = 7.5A) or current sharing, and thus increasing the power supply and system reliability. Though the PMH-24V50WCA□ is not designed for current sharing, a good current sharing between two power supplies can be achieved by following simple steps as below (Refer to Fig. 3 for the Connection Diagram).

Step 1.

Set output load condition for both supplies at 50% and measure the output voltages.

Step 2.

Adjust output voltages to the same level or within $\pm 25mV$ difference.

Step 3.

Connect PSU 1 and PSU 2 with the DRR-20A module and measure at $V_{in 1}$ & $V_{in 2}$ to verify the voltage difference. Ensure the voltages are within $\pm 25mV$.

Step 4.

Output voltage from DRR module V_{out} will be = V_O (output voltage of power supply) - V_{drop}^* (in DRR module).

* V_{drop} will vary from 0.60V to 0.90V (Typical 0.65V) depending on the load current and surrounding air temperature.

PMH Panel Mount Power Supply

24V 50W 1 Phase / PMH-24V50WCA□

Others

Delta RoHS Compliant



Restriction of the usage of hazardous substances

The European directive 2011/65/EU limits the maximum impurity level of homogeneous materials such as lead, mercury, cadmium, chrome, polybrominated flame retardants PBB and PBDE for the use in electrical and electronic equipment. RoHS is the abbreviation for "Restriction of the use of certain hazardous substances in electrical and electronic equipment".

This product conforms to this standard.

AMEYA360

Components Supply Platform

Authorized Distribution Brand :



Website :

Welcome to visit www.ameya360.com

Contact Us :

➤ Address :

401 Building No.5, JiuGe Business Center, Lane 2301, Yishan Rd
Minhang District, Shanghai , China

➤ Sales :

Direct +86 (21) 6401-6692

Email amall@ameya360.com

QQ 800077892

Skype [ameyasales1](#) [ameyasales2](#)

➤ Customer Service :

Email service@ameya360.com

➤ Partnership :

Tel +86 (21) 64016692-8333

Email mkt@ameya360.com