

0.9-Ω DUAL SPST ANALOG SWITCH 5-V/3.3-V 2-CHANNEL ANALOG SWITCH

Check for Samples: [TS5A23166](#)

FEATURES

- Isolation in Powered-Down Mode, $V_+ = 0$
- Low ON-State Resistance (0.9 Ω)
- Control Inputs Are 5.5-V Tolerant
- Low Charge Injection
- Excellent ON-State Resistance Matching
- Low Total Harmonic Distortion (THD)
- 1.65-V to 5.5-V Single-Supply Operation
- Latch-Up Performance Exceeds 100 mA Per JESD 78, Class II
- ESD Performance Tested Per JESD 22
 - 2000-V Human-Body Model (A114-B, Class II)
 - 1000-V Charged-Device Model (C101)

APPLICATIONS

- Cell Phones
- PDAs
- Portable Instrumentation
- Audio and Video Signal Routing
- Low-Voltage Data-Acquisition Systems
- Communication Circuits
- Modems
- Hard Drives
- Computer Peripherals
- Wireless Terminals and Peripherals

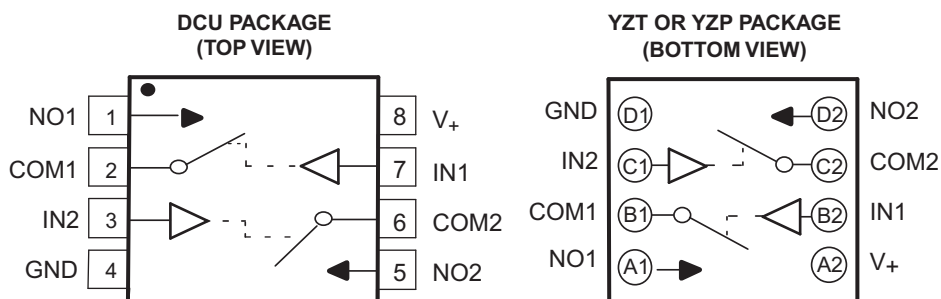

DESCRIPTION/ORDERING INFORMATION

The TS5A23166 is a dual single-pole single-throw (SPST) analog switch that is designed to operate from 1.65 V to 5.5 V. The device offers a low ON-state resistance and an excellent channel-to-channel ON-state resistance matching. The device has excellent total harmonic distortion (THD) performance and consumes very low power. These features make this device suitable for portable audio applications.

Table 1. ORDERING INFORMATION

T _A	PACKAGE ^{(1) (2)}		ORDERABLE PART NUMBER	TOP-SIDE MARKING ⁽³⁾
–40°C to 85°C	NanoFree™ – WCSP (DSBGA) 0.23-mm Large Bump – YZT (Pb-free)	Tape and reel	TS5A23166YZTR	JM_
	NanoFree™ – WCSP (DSBGA) 0.23-mm Large Bump – YZP (Pb-free)		TS5A23166YZPR	
	VSSOP – DCU (Pb-free)	Tape and reel	TS5A23166DCUR	JAM_

(1) Package drawings, thermal data, and symbolization are available at www.ti.com/packaging.

(2) For the most current package and ordering information, see the Package Option Addendum at the end of this document, or see the TI website at www.ti.com.

(3) The actual top-side marking has one additional character that designates the assembly/test site.



Please be aware that an important notice concerning availability, standard warranty, and use in critical applications of Texas Instruments semiconductor products and disclaimers thereto appears at the end of this data sheet.

SUMMARY OF CHARACTERISTICS⁽¹⁾

Configuration	Dual Single Pole, Single Throw (2 × SPST)
Number of channels	2
ON-state resistance (r_{on})	0.9 Ω
ON-state resistance match (Δr_{on})	0.1 Ω
ON-state resistance flatness ($r_{on(Flat)}$)	0.25 Ω
Turn-on/turn-off time (t_{ON}/t_{OFF})	7.5 ns/9 ns
Charge injection (Q_C)	6 pC
Bandwidth (BW)	150 MHz
OFF isolation (O_{ISO})	–62 dB at 1 MHz
Crosstalk (X_{TALK})	–85 dB at 1 MHz
Total harmonic distortion (THD)	0.005%
Leakage current ($I_{COM(OFF)}$)	± 20 nA
Power-supply current (I_+)	0.1 μ A
Package options	8-pin SSOP, VSSOP, and WCSP

(1) $V_+ = 5$ V, $T_A = 25^\circ\text{C}$ **FUNCTION TABLE**

IN	NO TO COM, COM TO NO
L	OFF
H	ON

Absolute Maximum Ratings^{(1) (2)}

over operating free-air temperature range (unless otherwise noted)

		MIN	MAX	UNIT
V_+	Supply voltage range ⁽³⁾	–0.5	6.5	V
V_{NO} V_{COM}	Analog voltage range ^{(3) (4) (5)}	–0.5	$V_+ + 0.5$	V
I_K	Analog port diode current	$V_{NO}, V_{COM} < 0$		mA
I_{NO} I_{COM}	On-state switch current On-state peak switch current ⁽⁶⁾	$V_{NO}, V_{COM} = 0$ to V_+		mA
V_I	Digital input voltage range ^{(3) (4)}	–0.5	6.5	V
I_{IK}	Digital input clamp current	$V_I < 0$		mA
I_+	Continuous current through V_+		100	mA
I_{GND}	Continuous current through GND	–100	100	mA
θ_{JA}	Package thermal impedance ⁽⁷⁾	DCU package		227
		YZT/YZP package		102
T_{stg}	Storage temperature range	–65	150	$^\circ\text{C}$

- (1) Stresses beyond those listed under "absolute maximum ratings" may cause permanent damage to the device. These are stress ratings only, and functional operation of the device at these or any other conditions beyond those indicated under "recommended operating conditions" is not implied. Exposure to absolute-maximum-rated conditions for extended periods may affect device reliability.
- (2) The algebraic convention, whereby the most negative value is a minimum and the most positive value is a maximum
- (3) All voltages are with respect to ground, unless otherwise specified.
- (4) The input and output voltage ratings may be exceeded if the input and output clamp-current ratings are observed.
- (5) This value is limited to 5.5 V maximum.
- (6) Pulse at 1-ms duration < 10% duty cycle.
- (7) The package thermal impedance is calculated in accordance with JESD 51-7.

Electrical Characteristics for 5-V Supply⁽¹⁾
 $V_+ = 4.5 \text{ V to } 5.5 \text{ V}$, $T_A = -40^\circ\text{C to } 85^\circ\text{C}$ (unless otherwise noted)

PARAMETER	SYMBOL	TEST CONDITIONS	T_A	V_+	MIN	TYP	MAX	UNIT	
Analog Switch									
Analog signal range	V_{COM}, V_{NO}				0		V_+	V	
Peak ON resistance	r_{peak}	$0 \leq V_{NO} \leq V_+$, $I_{COM} = -100 \text{ mA}$,	Switch ON, See Figure 12	25°C	4.5 V	0.9	1.1	Ω	
				Full		1.2			
ON-state resistance	r_{on}	$V_{NO} = 2.5 \text{ V}$, $I_{COM} = -100 \text{ mA}$,	Switch ON, See Figure 12	25°C	4.5 V	0.75	0.9	Ω	
				Full		1			
ON-state resistance match between channels	Δr_{on}	$V_{NO} = 2.5 \text{ V}$, $I_{COM} = -100 \text{ mA}$,	Switch ON, See Figure 12	25°C	4.5 V	0.04	0.1	Ω	
				Full		0.1			
ON-state resistance flatness	$r_{on(Flat)}$	$0 \leq V_{NO} \leq V_+$, $I_{COM} = -100 \text{ mA}$,	Switch ON, See Figure 12	25°C	4.5 V	0.2		Ω	
				25°C		0.15	0.25		
				Full		0.25			
NO OFF leakage current	$I_{NO(OFF)}$	$V_{NO} = 1 \text{ V}$, $V_{COM} = 4.5 \text{ V}$, or $V_{NO} = 4.5 \text{ V}$, $V_{COM} = 1 \text{ V}$,	Switch OFF, See Figure 13	25°C	5.5 V	0 V	4	20	nA
				Full		-150	150		
	$I_{NO(PWROFF)}$	$V_{NO} = 0 \text{ to } 5.5 \text{ V}$, $V_{COM} = 5.5 \text{ V to } 0$,	Switch OFF, See Figure 13	25°C	0 V	-10	0.2	10	μA
				Full		-50	50		
COM OFF leakage current	$I_{COM(OFF)}$	$V_{COM} = 1 \text{ V}$, $V_{NO} = 4.5 \text{ V}$, or $V_{COM} = 4.5 \text{ V}$, $V_{NO} = 1 \text{ V}$,	Switch OFF, See Figure 13	25°C	5.5 V	0 V	4	20	nA
				Full		-150	150		
	$I_{COM(PWROFF)}$	$V_{COM} = 0 \text{ to } 5.5 \text{ V}$, $V_{NO} = 5.5 \text{ V to } 0$,	Switch OFF, See Figure 13	25°C	0 V	-10	0.2	10	μA
				Full		-50	50		
NO ON leakage current	$I_{NO(ON)}$	$V_{NO} = 1 \text{ V}$, $V_{COM} = \text{Open}$, or $V_{NO} = 4.5 \text{ V}$, $V_{COM} = \text{Open}$,	Switch ON, See Figure 14	25°C	5.5 V	-5	0.4	5	nA
				Full		-50	50		
COM ON leakage current	$I_{COM(ON)}$	$V_{COM} = 1 \text{ V}$, $V_{NO} = \text{Open}$, or $V_{COM} = 4.5 \text{ V}$, $V_{NO} = \text{Open}$,	Switch ON, See Figure 14	25°C	5.5 V	-5	0.4	5	nA
				Full		-50	50		
Digital Control Inputs (IN1, IN2)⁽²⁾									
Input logic high	V_{IH}		Full		2.4		5.5	V	
Input logic low	V_{IL}		Full		0		0.8	V	
Input leakage current	I_{IH}, I_{IL}	$V_I = 5.5 \text{ V or } 0$	25°C	5.5 V	-2	0.3	2	nA	
			Full		-20	20			

(1) The algebraic convention, whereby the most negative value is a minimum and the most positive value is a maximum

(2) All unused digital inputs of the device must be held at V_+ or GND to ensure proper device operation. Refer to the TI application report, *Implications of Slow or Floating CMOS Inputs*, literature number SCBA004.

Electrical Characteristics for 5-V Supply⁽¹⁾ (continued)

$V_+ = 4.5\text{ V to }5.5\text{ V}$, $T_A = -40^\circ\text{C to }85^\circ\text{C}$ (unless otherwise noted)

PARAMETER	SYMBOL	TEST CONDITIONS	T_A	V_+	MIN	TYP	MAX	UNIT	
Dynamic									
Turn-on time	t_{ON}	$V_{COM} = V_+$, $R_L = 50\ \Omega$,	$C_L = 35\text{ pF}$, See Figure 16	25°C	5 V	1	4.5	7.5	ns
				Full	4.5 V to 5.5 V	1		9	
Turn-off time	t_{OFF}	$V_{COM} = V_+$, $R_L = 50\ \Omega$,	$C_L = 35\text{ pF}$, See Figure 16	25°C	5 V	4.5	8	11	ns
				Full	4.5 V to 5.5 V	3.5		13	
Charge injection	Q_C	$V_{GEN} = 0$, $R_{GEN} = 0$,	$C_L = 1\text{ nF}$, See Figure 20	25°C	5 V		6	pC	
NO OFF capacitance	$C_{NO(OFF)}$	$V_{NO} = V_+$ or GND, Switch OFF,	See Figure 15	25°C	5 V		19	pF	
COM OFF capacitance	$C_{COM(OFF)}$	$V_{COM} = V_+$ or GND, Switch OFF,	See Figure 15	25°C	5 V		18	pF	
NO ON capacitance	$C_{NO(ON)}$	$V_{NO} = V_+$ or GND, Switch ON,	See Figure 15	25°C	5 V		35.5	pF	
COM ON capacitance	$C_{COM(ON)}$	$V_{COM} = V_+$ or GND, Switch ON,	See Figure 15	25°C	5 V		35.5	pF	
Digital input capacitance	C_I	$V_I = V_+$ or GND,	See Figure 15	25°C	5 V		2	pF	
Bandwidth	BW	$R_L = 50\ \Omega$, Switch ON,	See Figure 17	25°C	5 V		150	MHz	
OFF isolation	O_{ISO}	$R_L = 50\ \Omega$, $f = 1\text{ MHz}$,	Switch OFF, See Figure 18	25°C	5 V		-62	dB	
Crosstalk	X_{TALK}	$R_L = 50\ \Omega$, $f = 1\text{ MHz}$,	Switch ON, See Figure 19	25°C	5 V		-85	dB	
Total harmonic distortion	THD	$R_L = 600\ \Omega$, $C_L = 50\text{ pF}$,	$f = 20\text{ Hz to }20\text{ kHz}$, See Figure 21	25°C	5 V		0.005	%	
Supply									
Positive supply current	I_+	$V_I = V_+$ or GND,	Switch ON or OFF	25°C	5.5 V	0.01	0.1	μA	
				Full			1		

(1) The algebraic convention, whereby the most negative value is a minimum and the most positive value is a maximum

Electrical Characteristics for 3.3-V Supply⁽¹⁾
 $V_+ = 3\text{ V to }3.6\text{ V}$, $T_A = -40^\circ\text{C to }85^\circ\text{C}$ (unless otherwise noted)

PARAMETER	SYMBOL	TEST CONDITIONS	T_A	V_+	MIN	TYP	MAX	UNIT	
Analog Switch									
Analog signal range	V_{COM}, V_{NO}				0		V_+	V	
Peak ON resistance	r_{peak}	$0 \leq V_{NO} \leq V_+$, $I_{COM} = -100\text{ mA}$, Switch ON, See Figure 12	25°C	3 V		1.3	1.6	Ω	
			Full				1.8		
ON-state resistance	r_{on}	$V_{NO} = 2\text{ V}$, $I_{COM} = -100\text{ mA}$, Switch ON, See Figure 12	25°C	3 V		1.1	1.5	Ω	
			Full				1.7		
ON-state resistance match between channels	Δr_{on}	$V_{NO} = 2\text{ V}, 0.8\text{ V}$, $I_{COM} = -100\text{ mA}$, Switch ON, See Figure 12	25°C	3 V		0.04	0.1	Ω	
			Full				0.1		
ON-state resistance flatness	$r_{on(flat)}$	$0 \leq V_{NO} \leq V_+$, $I_{COM} = -100\text{ mA}$, Switch ON, See Figure 12	25°C	3 V		0.3		Ω	
			25°C				0.15		0.25
			Full						0.25
NO OFF leakage current	$I_{NO(OFF)}$	$V_{NO} = 1\text{ V}, V_{COM} = 3\text{ V}$, or $V_{NO} = 3\text{ V}, V_{COM} = 1\text{ V}$, Switch OFF, See Figure 13	25°C	3.6 V		-5	0.5	5	nA
			Full				-50	50	
	$I_{NO(PWROFF)}$	$V_{NO} = 0\text{ to }3.6\text{ V}$, $V_{COM} = 3.6\text{ V to }0$, Switch OFF, See Figure 13	25°C	0 V		-5	0.1	5	μA
			Full				-25	25	
COM OFF leakage current	$I_{COM(OFF)}$	$V_{COM} = 1\text{ V}, V_{NO} = 3\text{ V}$, or $V_{COM} = 3\text{ V}, V_{NO} = 1\text{ V}$, Switch OFF, See Figure 13	25°C	3.6 V		-5	0.5	5	nA
			Full				-50	50	
	$I_{COM(PWROFF)}$	$V_{COM} = 0\text{ to }3.6\text{ V}$, $V_{NO} = 3.6\text{ V to }0$, Switch OFF, See Figure 13	25°C	0 V		-5	0.1	5	μA
			Full				-25	25	
NO ON leakage current	$I_{NO(ON)}$	$V_{NO} = 1\text{ V}$, $V_{COM} = \text{Open}$, or $V_{NO} = 3\text{ V}$, $V_{COM} = \text{Open}$, Switch ON, See Figure 14	25°C	3.6 V		-2	0.3	2	nA
			Full				-20	20	
COM ON leakage current	$I_{COM(ON)}$	$V_{COM} = 1\text{ V}$, $V_{NO} = \text{Open}$, or $V_{COM} = 3\text{ V}$, $V_{NO} = \text{Open}$, Switch ON, See Figure 14	25°C	3.6 V		-2	0.3	2	nA
			Full				-20	20	
Digital Control Inputs (IN1, IN2)⁽²⁾									
Input logic high	V_{IH}		Full			2		5.5	V
Input logic low	V_{IL}		Full			0		0.8	V
Input leakage current	I_{IH}, I_{IL}	$V_I = 5.5\text{ V or }0$	25°C	3.6 V		-2	0.3	2	nA
			Full						

(1) The algebraic convention, whereby the most negative value is a minimum and the most positive value is a maximum

(2) All unused digital inputs of the device must be held at V_+ or GND to ensure proper device operation. Refer to the TI application report, *Implications of Slow or Floating CMOS Inputs*, literature number SCBA004.

Electrical Characteristics for 3.3-V Supply⁽¹⁾ (continued)
 $V_+ = 3\text{ V to }3.6\text{ V}$, $T_A = -40^\circ\text{C to }85^\circ\text{C}$ (unless otherwise noted)

PARAMETER	SYMBOL	TEST CONDITIONS	T_A	V_+	MIN	TYP	MAX	UNIT
Dynamic								
Turn-on time	t_{ON}	$V_{COM} = V_+$, $R_L = 50\ \Omega$, $C_L = 35\text{ pF}$, See Figure 16	25°C	3.3 V	1.5	5	9.5	ns
			Full	3 V to 3.6 V	1		10	
Turn-off time	t_{OFF}	$V_{COM} = V_+$, $R_L = 50\ \Omega$, $C_L = 35\text{ pF}$, See Figure 16	25°C	3.3 V	4.5	8.5	11	ns
			Full	3 V to 3.6 V	3		12.5	
Charge injection	Q_C	$V_{GEN} = 0$, $R_{GEN} = 0$, $C_L = 1\text{ nF}$, See Figure 20	25°C	5 V		6		pC
NO OFF capacitance	$C_{NO(OFF)}$	$V_{NO} = V_+$ or GND, Switch OFF, See Figure 15	25°C	3.3 V		19.5		pF
COM OFF capacitance	$C_{COM(OFF)}$	$V_{COM} = V_+$ or GND, Switch OFF, See Figure 15	25°C	3.3 V		18.5		pF
NO ON capacitance	$C_{NO(ON)}$	$V_{NO} = V_+$ or GND, Switch ON, See Figure 15	25°C	3.3 V		36		pF
COM ON capacitance	$C_{COM(ON)}$	$V_{COM} = V_+$ or GND, Switch ON, See Figure 15	25°C	3.3 V		36		pF
Digital input capacitance	C_I	$V_I = V_+$ or GND, See Figure 15	25°C	3.3 V		2		pF
Bandwidth	BW	$R_L = 50\ \Omega$, Switch ON, See Figure 17	25°C	3.3 V		150		MHz
OFF isolation	O_{ISO}	$R_L = 50\ \Omega$, $f = 1\text{ MHz}$, Switch OFF, See Figure 18	25°C	3.3 V		-62		dB
Crosstalk	X_{TALK}	$R_L = 50\ \Omega$, $f = 1\text{ MHz}$, Switch ON, See Figure 19	25°C	3.3 V		-85		dB
Total harmonic distortion	THD	$R_L = 600\ \Omega$, $C_L = 50\text{ pF}$, $f = 20\text{ Hz to }20\text{ kHz}$, See Figure 21	25°C	3.3 V		0.01		%
Supply								
Positive supply current	I_+	$V_I = V_+$ or GND, Switch ON or OFF	25°C	3.6 V	0.001	0.05	0.3	μA
			Full					

(1) The algebraic convention, whereby the most negative value is a minimum and the most positive value is a maximum

Electrical Characteristics for 2.5-V Supply⁽¹⁾
 $V_+ = 2.3 \text{ V to } 2.7 \text{ V}$, $T_A = -40^\circ\text{C to } 85^\circ\text{C}$ (unless otherwise noted)

PARAMETER	SYMBOL	TEST CONDITIONS	T_A	V_+	MIN	TYP	MAX	UNIT
Analog Switch								
Analog signal range	$V_{\text{COM}}, V_{\text{NO}}$				0		V_+	V
Peak ON resistance	r_{peak}	$0 \leq V_{\text{NO}} \leq V_+$, $I_{\text{COM}} = -8 \text{ mA}$,	Switch ON, See Figure 12	25°C Full	2.3 V	1.8	2.4 2.6	Ω
ON-state resistance	r_{on}	$V_{\text{NO}} = 1.8 \text{ V}$, $I_{\text{COM}} = -8 \text{ mA}$,	Switch ON, See Figure 12	25°C Full	2.3 V	1.2	2.1 2.4	Ω
ON-state resistance match between channels	Δr_{on}	$V_{\text{NO}} = 1.8 \text{ V}, 0.8 \text{ V}$, $I_{\text{COM}} = -8 \text{ mA}$,	Switch ON, See Figure 12	25°C Full	2.3 V	0.04	0.15 0.15	Ω
ON-state resistance flatness	$r_{\text{on (flat)}}$	$0 \leq V_{\text{NO}} \leq V_+$, $I_{\text{COM}} = -8 \text{ mA}$,	Switch ON, See Figure 12	25°C Full	2.3 V	0.7 0.4	0.6 0.6	Ω
NO OFF leakage current	$I_{\text{NO(OFF)}}$	$V_{\text{NO}} = 0.5 \text{ V}$, $V_{\text{COM}} = 2.3 \text{ V}$, or $V_{\text{NO}} = 2.3 \text{ V}$, $V_{\text{COM}} = 0.5 \text{ V}$,	Switch OFF, See Figure 13	25°C Full	2.7 V	-5 -50	0.3 50	nA
	$I_{\text{NO(PWROFF)}}$	$V_{\text{NO}} = 0 \text{ to } 2.7 \text{ V}$, $V_{\text{COM}} = 2.7 \text{ V to } 0$,	Switch OFF, See Figure 13	25°C Full	0 V	-2 -15	0.05 15	μA
COM OFF leakage current	$I_{\text{COM(OFF)}}$	$V_{\text{NO}} = 2.3 \text{ V}$, $V_{\text{COM}} = 0.5 \text{ V}$, or $V_{\text{NO}} = 0.5 \text{ V}$, $V_{\text{COM}} = 2.3 \text{ V}$,	Switch OFF, See Figure 13	25°C Full	2.7 V	-5 -50	0.3 50	nA
	$I_{\text{COM(PWROFF)}}$	$V_{\text{COM}} = 0 \text{ to } 2.7 \text{ V}$, $V_{\text{NO}} = 2.7 \text{ V to } 0$,	Switch OFF, See Figure 13	25°C Full	0 V	-2 -15	0.05 15	μA
NO ON leakage current	$I_{\text{NO(ON)}}$	$V_{\text{NO}} = 0.5 \text{ V}$, $V_{\text{COM}} = \text{Open}$, or $V_{\text{NO}} = 2.3 \text{ V}$, $V_{\text{COM}} = \text{Open}$,	Switch ON, See Figure 14	25°C Full	2.7 V	-2 -20	0.3 20	nA
COM ON leakage current	$I_{\text{COM(ON)}}$	$V_{\text{COM}} = 0.5 \text{ V}$, $V_{\text{NO}} = \text{Open}$, or $V_{\text{COM}} = 2.3 \text{ V}$, $V_{\text{NO}} = \text{Open}$,	Switch ON, See Figure 14	25°C Full	2.7 V	-2 -20	0.3 20	nA
Digital Control Inputs (IN1, IN2)								
Input logic high	V_{IH}			Full		1.8	5.5	V
Input logic low	V_{IL}			Full		0	0.6	V
Input leakage current	$I_{\text{IH}}, I_{\text{IL}}$	$V_I = 5.5 \text{ V or } 0$		25°C	2.7 V	-2	0.3	2
				Full		-20	20	nA

(1) The algebraic convention is used in this data sheet; the most negative value is shown in the minimum column.

Electrical Characteristics for 2.5-V Supply⁽¹⁾ (continued)

$V_+ = 2.3 \text{ V to } 2.7 \text{ V}$, $T_A = -40^\circ\text{C to } 85^\circ\text{C}$ (unless otherwise noted)

PARAMETER	SYMBOL	TEST CONDITIONS	T_A	V_+	MIN	TYP	MAX	UNIT
Dynamic								
Turn-on time	t_{ON}	$V_{COM} = V_+$, $R_L = 50 \Omega$, $C_L = 35 \text{ pF}$, See Figure 16	25°C	2.5 V	2	6	10	ns
			Full	2.3 V to 2.7 V	1		12	
Turn-off time	t_{OFF}	$V_{COM} = V_+$, $R_L = 50 \Omega$, $C_L = 35 \text{ pF}$, See Figure 16	25°C	2.5 V	4.5	8	12.5	ns
			Full	2.3 V to 2.7 V	3		15	
Charge injection	Q_C	$V_{GEN} = 0$, $R_{GEN} = 0$, $C_L = 1 \text{ nF}$, See Figure 20	25°C	2.5 V		4		pC
NO OFF capacitance	$C_{NO(OFF)}$	$V_{NO} = V_+$ or GND, Switch OFF, See Figure 15	25°C	2.5 V		19.5		pF
COM OFF capacitance	$C_{COM(OFF)}$	$V_{COM} = V_+$ or GND, Switch OFF, See Figure 15	25°C	2.5 V		18.5		pF
NO ON capacitance	$C_{NO(ON)}$	$V_{NO} = V_+$ or GND, Switch ON, See Figure 15	25°C	2.5 V		36.5		pF
COM ON capacitance	$C_{COM(ON)}$	$V_{COM} = V_+$ or GND, Switch ON, See Figure 15	25°C	2.5 V		36.5		pF
Digital input capacitance	C_I	$V_I = V_+$ or GND, See Figure 15	25°C	2.5 V		2		pF
Bandwidth	BW	$R_L = 50 \Omega$, Switch ON, See Figure 17	25°C	2.5 V		150		MHz
OFF isolation	O_{ISO}	$R_L = 50 \Omega$, $f = 1 \text{ MHz}$, Switch OFF, See Figure 18	25°C	2.5 V		-62		dB
Crosstalk	X_{TALK}	$R_L = 50 \Omega$, $f = 1 \text{ MHz}$, Switch ON, See Figure 19	25°C	2.5 V		-85		dB
Total harmonic distortion	THD	$R_L = 600 \Omega$, $C_L = 50 \text{ pF}$, $f = 20 \text{ Hz to } 20 \text{ kHz}$, See Figure 21	25°C	2.5 V		0.02		%
Supply								
Positive supply current	I_+	$V_I = V_+$ or GND, Switch ON or OFF	25°C	2.7 V	0.001	0.02		μA
			Full			0.25		

(1) The algebraic convention is used in this data sheet; the most negative value is shown in the minimum column.

Electrical Characteristics for 1.8-V Supply⁽¹⁾
 $V_+ = 1.65\text{ V to }1.95\text{ V}$, $T_A = -40^\circ\text{C to }85^\circ\text{C}$ (unless otherwise noted)

PARAMETER	SYMBOL	TEST CONDITIONS	T_A	V_+	MIN	TYP	MAX	UNIT
Analog Switch								
Analog signal range	V_{COM}, V_{NO}				0		V_+	V
Peak ON resistance	r_{peak}	$0 \leq V_{NO} \leq V_+$, $I_{COM} = -2\text{ mA}$, Switch ON, See Figure 12	25°C Full	1.65 V		4.2	25 30	Ω
ON-state resistance	r_{on}	$V_{NO} = 0.6\text{ V}, 1.5\text{ V}$, $I_{COM} = -2\text{ mA}$, Switch ON, See Figure 12	25°C Full	1.65 V		1.6	3.9 4	Ω
ON-state resistance match between channels	Δr_{on}	$V_{NO} = 1.5\text{ V}$, $I_{COM} = -2\text{ mA}$, Switch ON, See Figure 12	25°C Full	1.65 V		0.04	0.2 0.2	Ω
ON-state resistance flatness	$r_{on (flat)}$	$0 \leq V_{NO} \leq V_+$, $I_{COM} = -2\text{ mA}$, $V_{NO} = 0.6\text{ V}, 1.5\text{ V}$, $I_{COM} = -2\text{ mA}$, Switch ON, See Figure 12	25°C Full	1.65 V		2.8 4.1	22 27	Ω
NO OFF leakage current	$I_{NO(OFF)}$	$V_{NO} = 0.3\text{ V}$, $V_{COM} = 1.65\text{ V}$, or $V_{NO} = 1.65\text{ V}$, $V_{COM} = 0.3\text{ V}$, Switch OFF, See Figure 13	25°C	1.95 V	-5	0.3	5	nA
			Full				-50	
	$I_{NO(PWROFF)}$	$V_{NO} = 0\text{ to }1.95\text{ V}$, $V_{COM} = 1.95\text{ V to }0$, Switch OFF, See Figure 13	25°C	0 V	-2	0.05	2	μA
			Full				-10	
COM OFF leakage current	$I_{COM(OFF)}$	$V_{NO} = 1.65\text{ V}$, $V_{COM} = 0.3\text{ V}$, or $V_{NO} = 0.3\text{ V}$, $V_{COM} = 1.65\text{ V}$, Switch OFF, See Figure 13	25°C	1.95 V	-5	0.3	5	nA
			Full				-50	
	$I_{COM(PWROFF)}$	$V_{COM} = 0\text{ to }1.95\text{ V}$, $V_{NO} = 1.95\text{ V to }0$, Switch OFF, See Figure 13	25°C	0 V	-2	0.05	2	μA
			Full				-10	
NO ON leakage current	$I_{NO(ON)}$	$V_{NO} = 0.3\text{ V}$, $V_{COM} = \text{Open}$, or $V_{NO} = 1.65\text{ V}$, $V_{COM} = \text{Open}$, Switch ON, See Figure 14	25°C Full	1.95 V	-2	0.3	2 20	nA
COM ON leakage current	$I_{COM(ON)}$	$V_{NO} = \text{Open}$, $V_{COM} = 0.3\text{ V}$, or $V_{NO} = \text{Open}$, $V_{COM} = 1.65\text{ V}$, Switch ON, See Figure 14	25°C Full	1.95 V	-2	0.3	2 20	nA
Digital Control Inputs (IN1, IN2)								
Input logic high	V_{IH}		Full		1.5		5.5	V
Input logic low	V_{IL}		Full		0		0.6	V
Input leakage current	I_{IH}, I_{IL}	$V_I = 5.5\text{ V or }0$	25°C	1.95 V	-2	0.3	2	μA
			Full				-20	

(1) The algebraic convention is used in this data sheet; the most negative value is shown in the minimum column.

Electrical Characteristics for 1.8-V Supply⁽¹⁾ (continued)
 $V_+ = 1.65\text{ V to }1.95\text{ V}$, $T_A = -40^\circ\text{C to }85^\circ\text{C}$ (unless otherwise noted)

PARAMETER	SYMBOL	TEST CONDITIONS	T_A	V_+	MIN	TYP	MAX	UNIT	
Dynamic									
Turn-on time	t_{ON}	$V_{COM} = V_+$, $R_L = 50\ \Omega$,	$C_L = 35\text{ pF}$, See Figure 16	25°C	1.8 V	3	9	18	ns
				Full	1.65 V to 1.95 V	1		20	
Turn-off time	t_{OFF}	$V_{COM} = V_+$, $R_L = 50\ \Omega$,	$C_L = 35\text{ pF}$, See Figure 16	25°C	1.8 V	5	10	15.5	ns
				Full	1.65 V to 1.95 V	4		18.5	
Charge injection	Q_C	$V_{GEN} = 0$, $R_{GEN} = 0$,	$C_L = 1\text{ nF}$, See Figure 20	25°C	1.8 V		2	pC	
NO OFF capacitance	$C_{NO(OFF)}$	$V_{NO} = V_+$ or GND, Switch OFF,	See Figure 15	25°C	1.8 V		19.5	pF	
COM OFF capacitance	$C_{COM(OFF)}$	$V_{COM} = V_+$ or GND, Switch OFF,	See Figure 15	25°C	1.8 V		18.5	pF	
NO ON capacitance	$C_{NO(ON)}$	$V_{NO} = V_+$ or GND, Switch ON,	See Figure 15	25°C	1.8 V		36.5	pF	
COM ON capacitance	$C_{COM(ON)}$	$V_{COM} = V_+$ or GND, Switch ON,	See Figure 15	25°C	1.8 V		36.5	pF	
Digital input capacitance	C_I	$V_I = V_+$ or GND,	See Figure 15	25°C	1.8 V		2	pF	
Bandwidth	BW	$R_L = 50\ \Omega$, Switch ON,	See Figure 17	25°C	1.8 V		150	MHz	
OFF isolation	O_{ISO}	$R_L = 50\ \Omega$, $f = 1\text{ MHz}$,	Switch OFF, See Figure 18	25°C	1.8 V		-62	dB	
Total harmonic distortion	THD	$R_L = 600\ \Omega$, $C_L = 50\text{ pF}$,	$f = 20\text{ Hz to }20\text{ kHz}$, See Figure 21	25°C	1.8 V		0.055	%	
Supply									
Positive supply current	I_+	$V_I = V_+$ or GND,	Switch ON or OFF	25°C	1.95 V		0.001	0.01	μA
				Full				0.15	

(1) The algebraic convention is used in this data sheet; the most negative value is shown in the minimum column.

TYPICAL PERFORMANCE

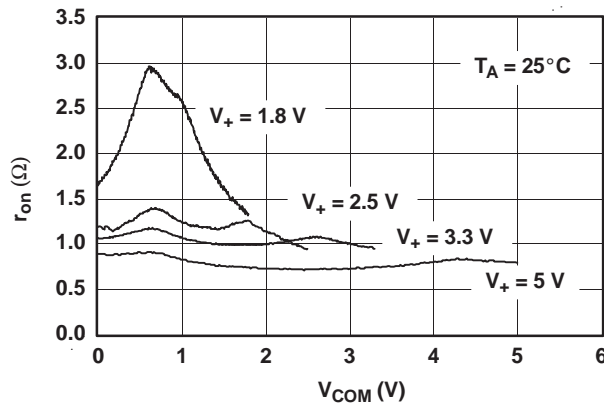

Figure 1. r_{on} vs V_{COM}

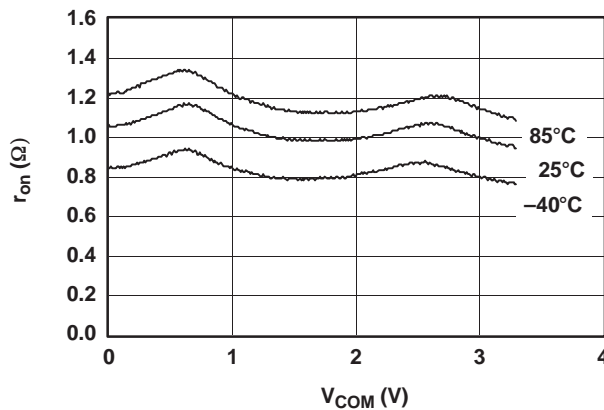

Figure 2. r_{on} vs V_{COM} ($V_+ = 3.3$ V)

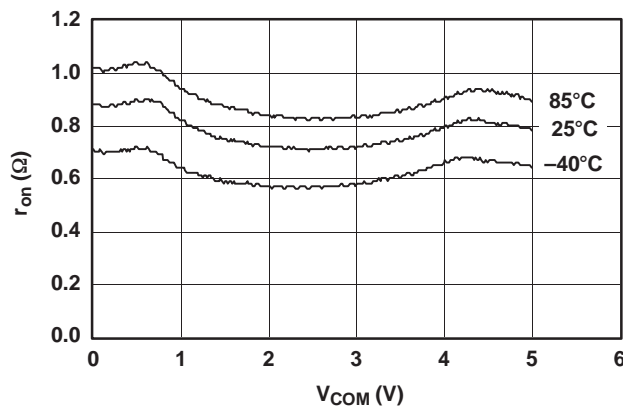

Figure 3. r_{on} vs V_{COM} ($V_+ = 5$ V)

TYPICAL PERFORMANCE (continued)

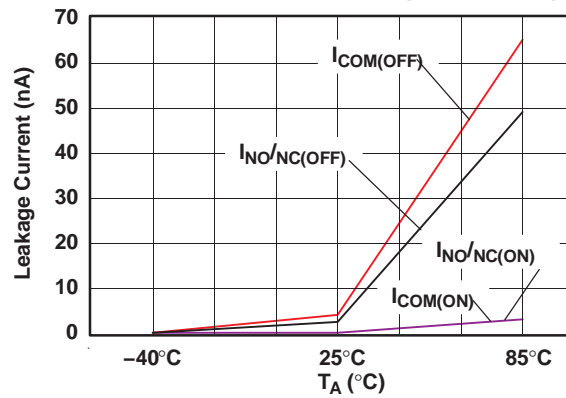

Figure 4. Leakage Current vs Temperature ($V_+ = 5.5\text{ V}$)

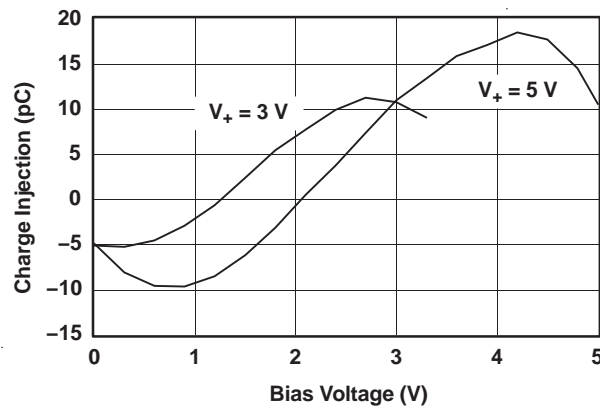

Figure 5. Charge Injection (Q_C) vs V_{COM}

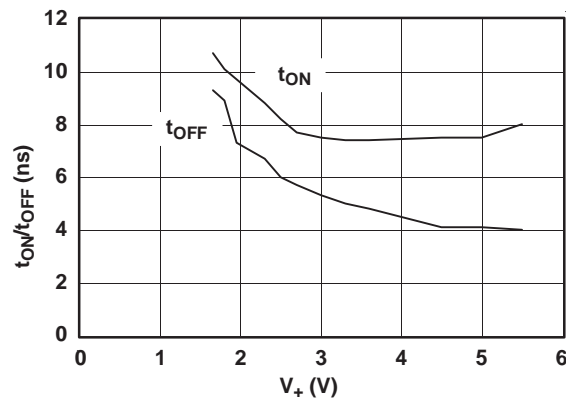

Figure 6. t_{ON} and t_{OFF} vs Supply Voltage

TYPICAL PERFORMANCE (continued)

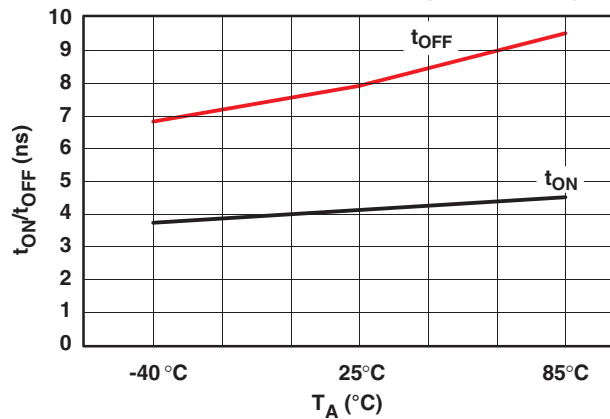

Figure 7. t_{ON} and t_{OFF} vs Temperature ($V_+ = 5$ V)

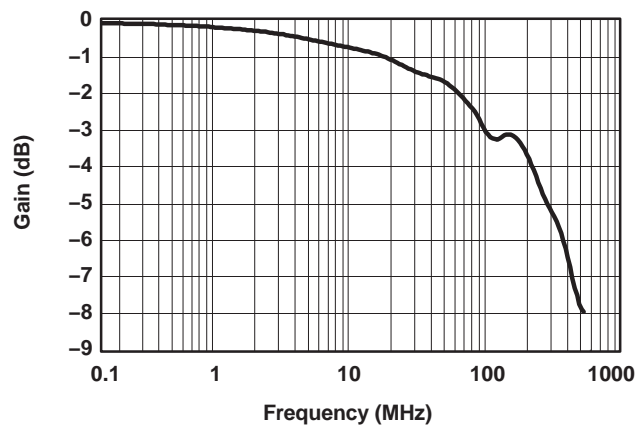

Figure 8. Bandwidth ($V_+ = 5$ V)

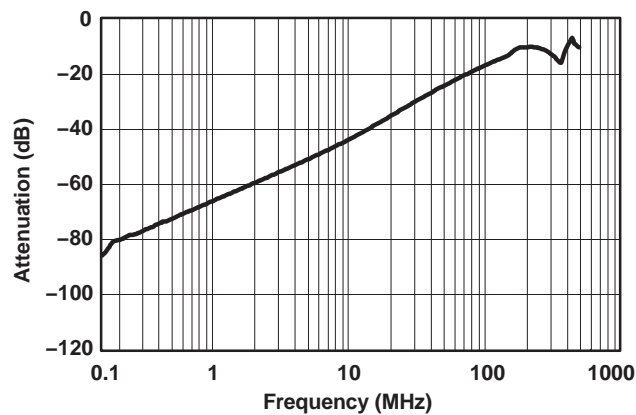

Figure 9. OFF Isolation and Crosstalk ($V_+ = 5$ V)

TYPICAL PERFORMANCE (continued)

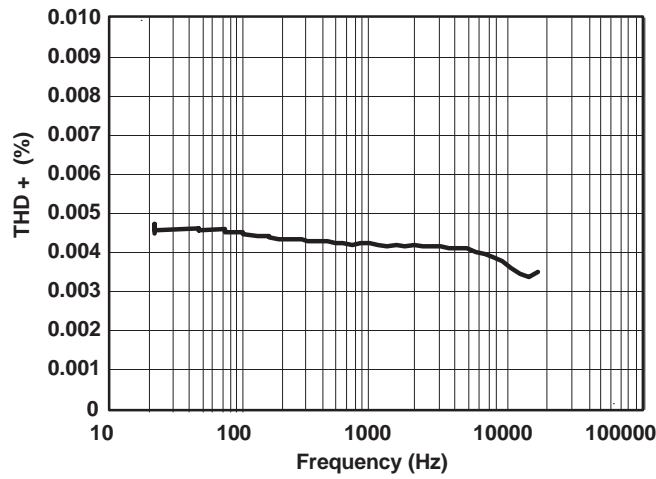

Figure 10. Total Harmonic Distortion vs Frequency

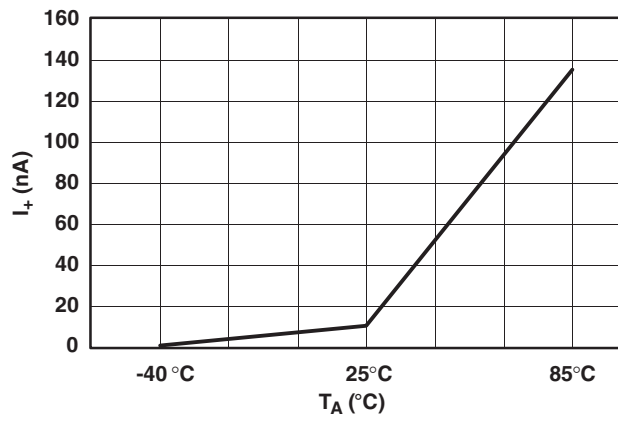

Figure 11. Power-Supply Current vs Temperature (V+ = 5 V)

Table 2. PIN DESCRIPTION

PIN NUMBER		NAME	DESCRIPTION
DCU	YZT or YZP		
1	A1	NO1	Normally open
2	B1	COM1	Common
3	C1	IN2	Digital control pin to connect COM to NO
4	D1	GND	Digital ground
5	D2	NO2	Normally open
6	C2	COM2	Common
7	B2	IN1	Digital control pin to connect COM to NO
8	A2	V ₊	Power Supply

Table 3. PARAMETER DESCRIPTION

SYMBOL	DESCRIPTION
V _{COM}	Voltage at COM
V _{NO}	Voltage at NO
r _{on}	Resistance between COM and NO ports when the channel is ON
r _{on(flat)}	Difference between the maximum and minimum value of r _{on} in a channel over the specified range of conditions
I _{NO(OFF)}	Leakage current measured at the NO port, with the corresponding channel (NO to COM) in the OFF state
I _{NO(ON)}	Leakage current measured at the NO port, with the corresponding channel (NO to COM) in the ON state and the output (COM) open
I _{COM(OFF)}	Leakage current measured at the COM port, with the corresponding channel (COM to NO) in the OFF state
I _{COM(ON)}	Leakage current measured at the COM port, with the corresponding channel (COM to NO) in the ON state and the output (NO) open
V _{IH}	Minimum input voltage for logic high for the control input (IN)
V _{IL}	Maximum input voltage for logic low for the control input (IN)
V _I	Voltage at the control input (IN)
I _{IH} , I _{IL}	Leakage current measured at the control input (IN)
t _{ON}	Turn-on time for the switch. This parameter is measured under the specified range of conditions and by the propagation delay between the digital control (IN) signal and analog output (COM or NO) signal when the switch is turning ON.
t _{OFF}	Turn-off time for the switch. This parameter is measured under the specified range of conditions and by the propagation delay between the digital control (IN) signal and analog output (COM or NO) signal when the switch is turning OFF.
Q _C	Charge injection is a measurement of unwanted signal coupling from the control (IN) input to the analog (NO or COM) output. This is measured in coulomb (C) and measured by the total charge induced due to switching of the control input. Charge injection, Q _C = C _L × ΔV _{COM} . C _L is the load capacitance and ΔV _{COM} is the change in analog output voltage.
C _{NO(OFF)}	Capacitance at the NO port when the corresponding channel (NO to COM) is OFF
C _{NO(ON)}	Capacitance at the NO port when the corresponding channel (NO to COM) is ON
C _{COM(OFF)}	Capacitance at the COM port when the corresponding channel (COM to NO) is OFF
C _{COM(ON)}	Capacitance at the COM port when the corresponding channel (COM to NO) is ON
C _I	Capacitance of IN
O _{ISO}	OFF isolation of the switch is a measurement of OFF-state switch impedence. This is measured in dB in a specific frequency, with the corresponding channel (NO to COM) in the OFF state.
BW	Bandwidth of the switch. This is the frequency in which the gain of an ON channel is –3 dB below the DC gain.
THD	Total harmonic distortion is defined as the ratio of the root mean square (RMS) value of the second, third, and higher harmonics to the magnitude of fundamental harmonic.
I ₊	Static power-supply current with the control (IN) pin at V ₊ or GND
ΔI ₊	This is the increase in I ₊ for each control (IN) input that is at the specified voltage, rather than at V ₊ or GND.

PARAMETER MEASUREMENT INFORMATION

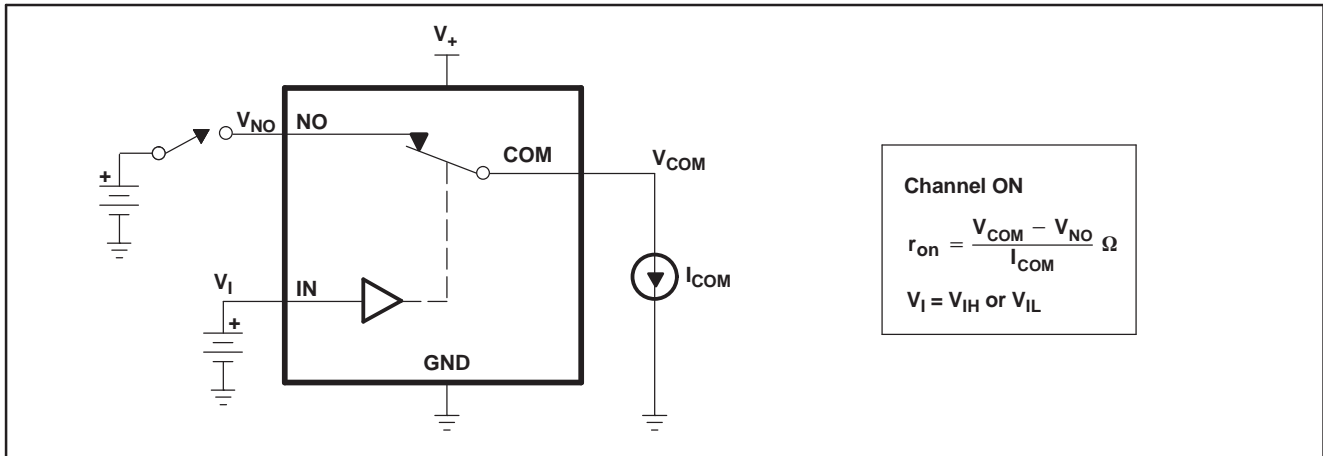

Figure 12. ON-State Resistance (r_{on})

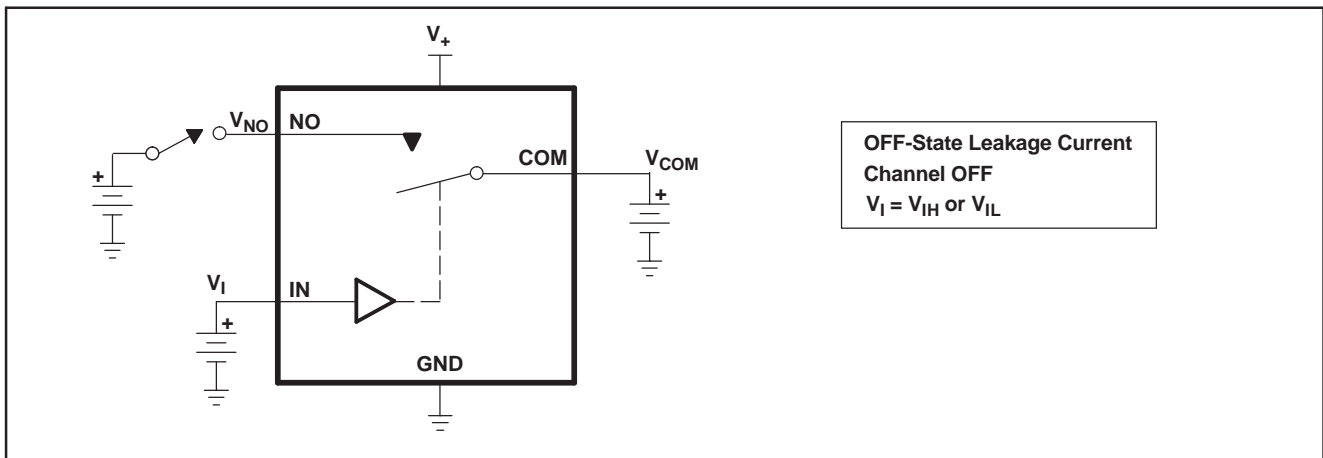

Figure 13. OFF-State Leakage Current ($I_{COM(OFF)}$, $I_{NC(OFF)}$, $I_{COM(PWROFF)}$, $I_{NC(PWR(F))}$)

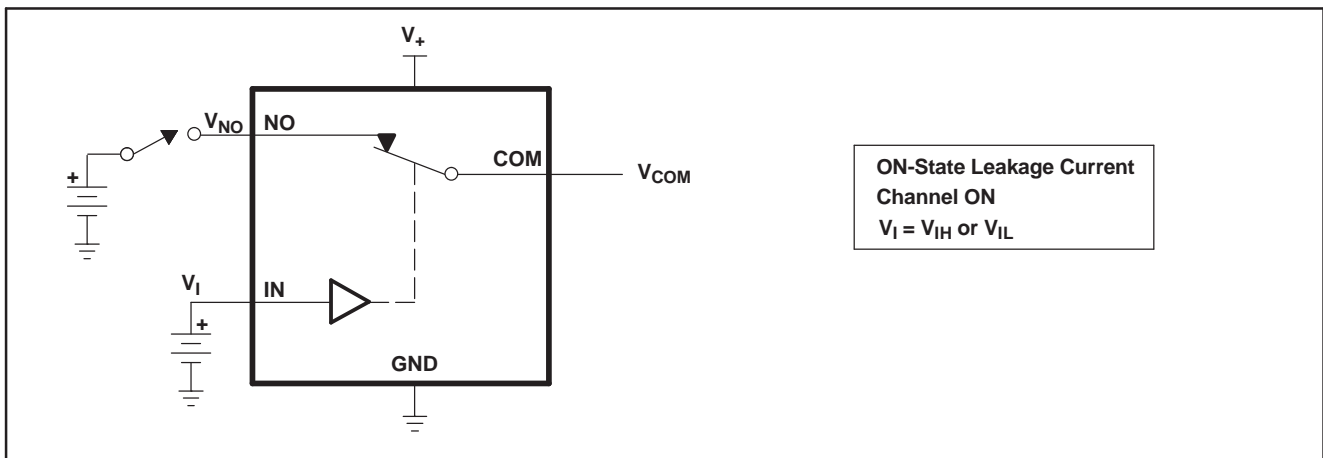

Figure 14. ON-State Leakage Current ($I_{COM(ON)}$, $I_{NC(ON)}$)

PARAMETER MEASUREMENT INFORMATION (continued)

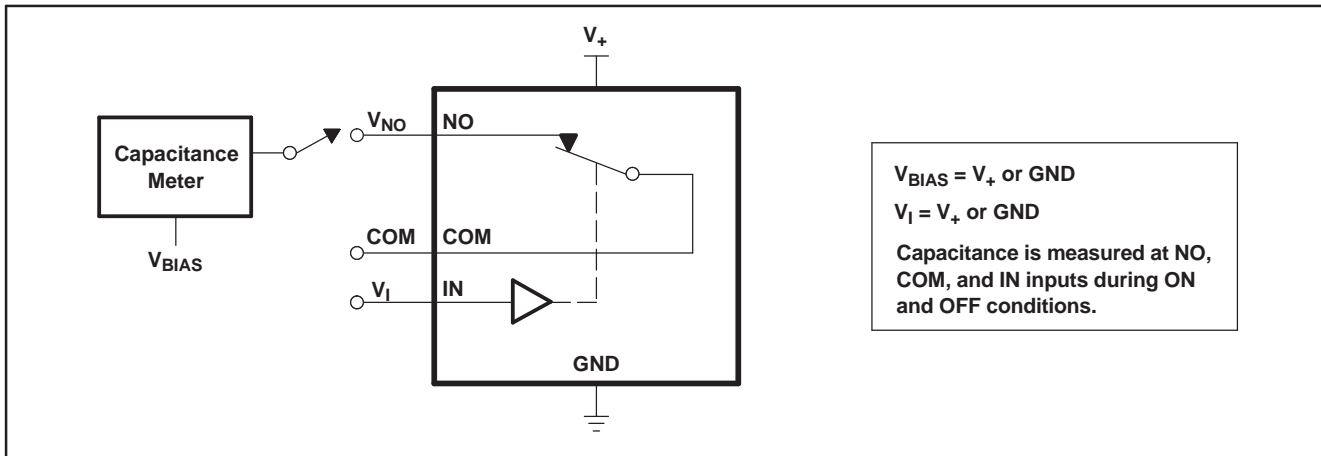
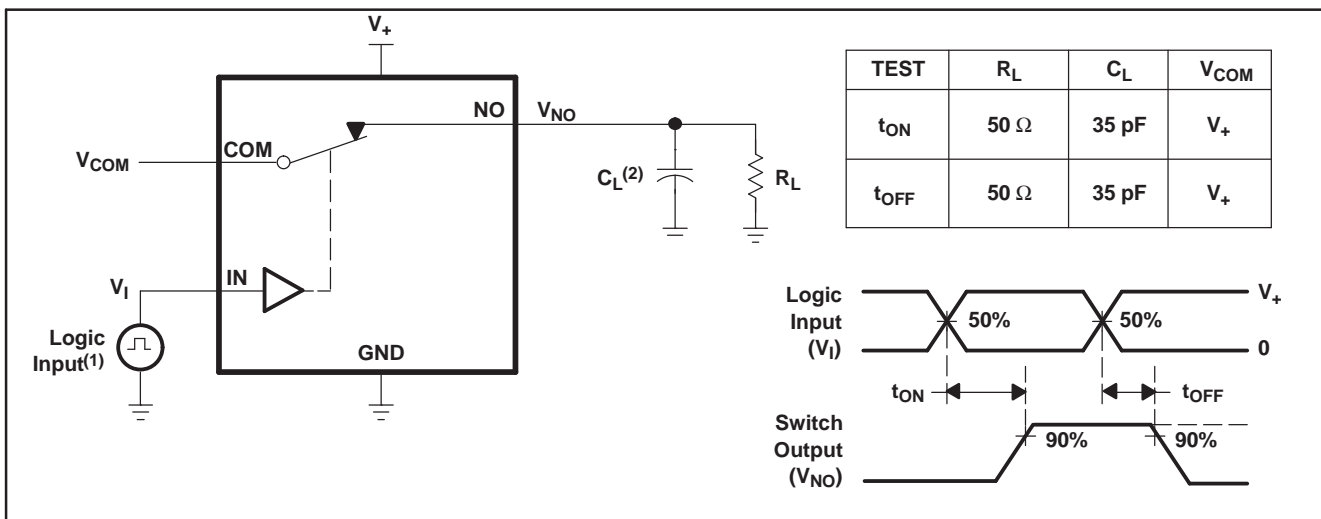

Figure 15. Capacitance (C_I , $C_{COM(OFF)}$, $C_{COM(ON)}$, $C_{NC(OFF)}$, $C_{NC(ON)}$)



(1) All input pulses are supplied by generators having the following characteristics: PRR \leq 10 MHz, $Z_O = 50 \Omega$, $t_r < 5$ ns, $t_f < 5$ ns.

(2) C_L includes probe and jig capacitance.

Figure 16. Turn-On (t_{ON}) and Turn-Off Time (t_{OFF})

PARAMETER MEASUREMENT INFORMATION (continued)

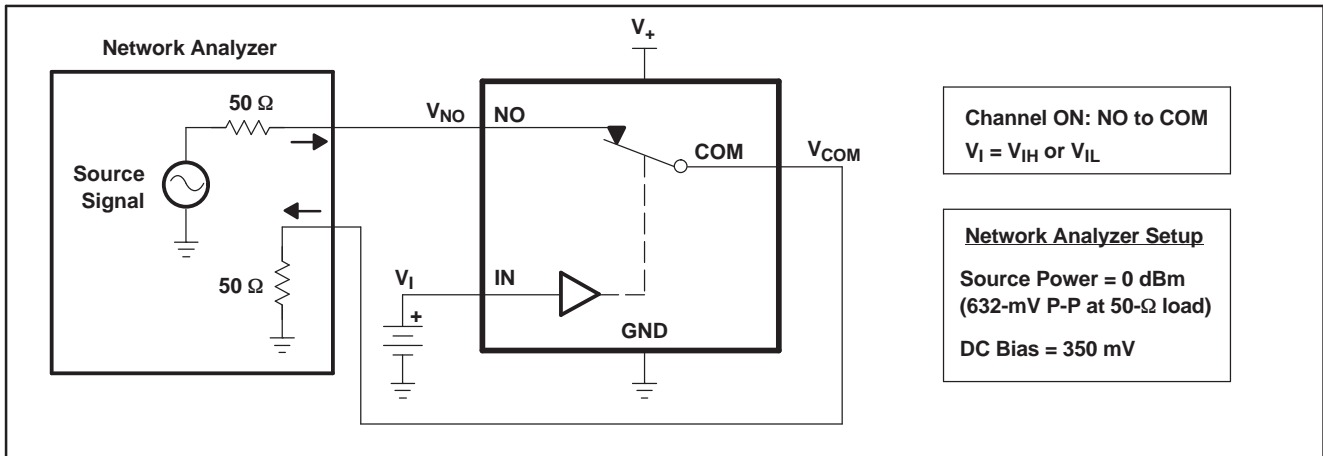

Figure 17. Bandwidth (BW)

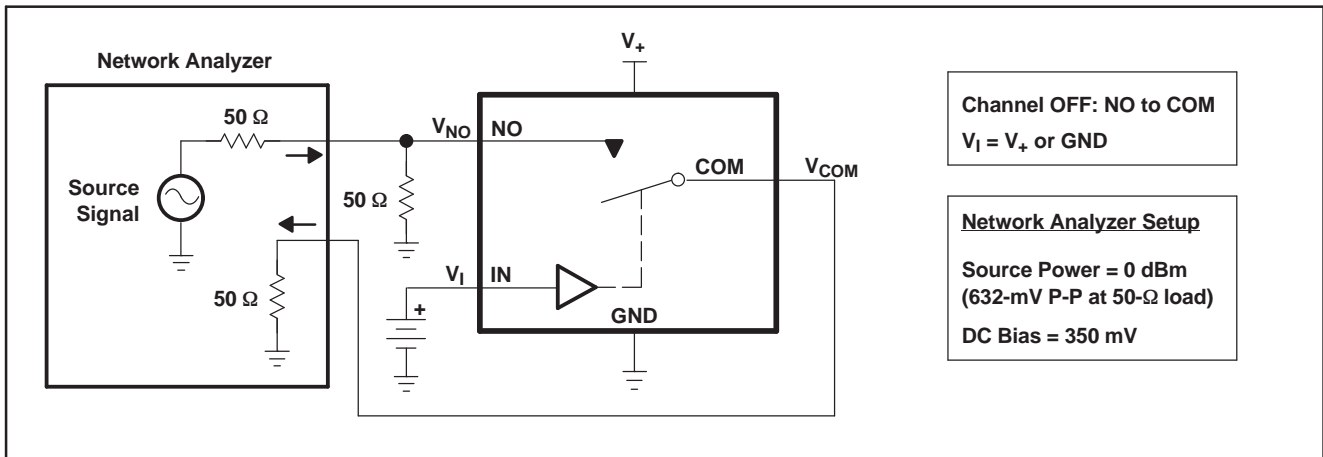

Figure 18. OFF Isolation (O_{ISO})

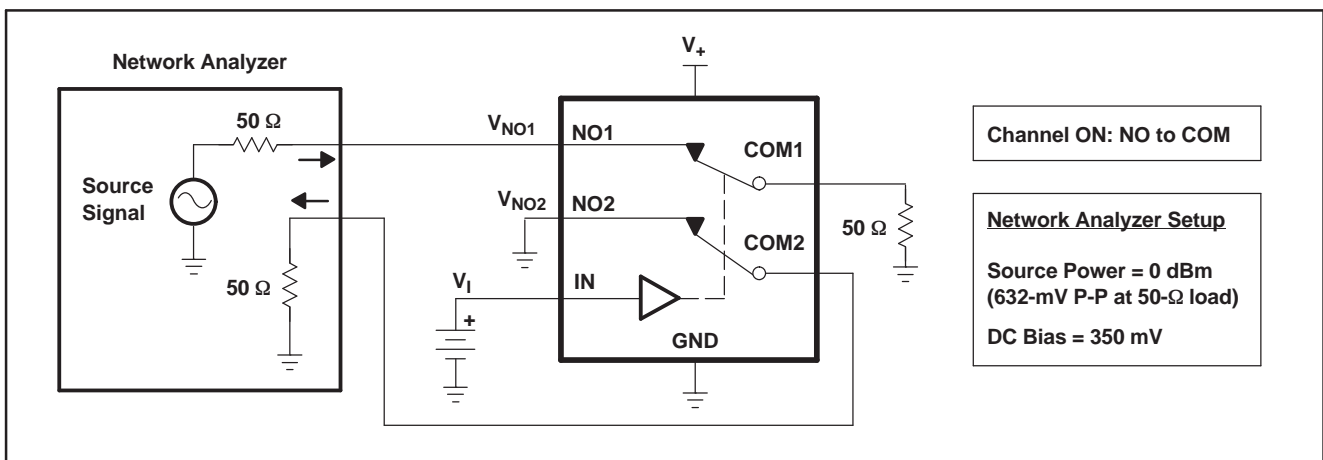
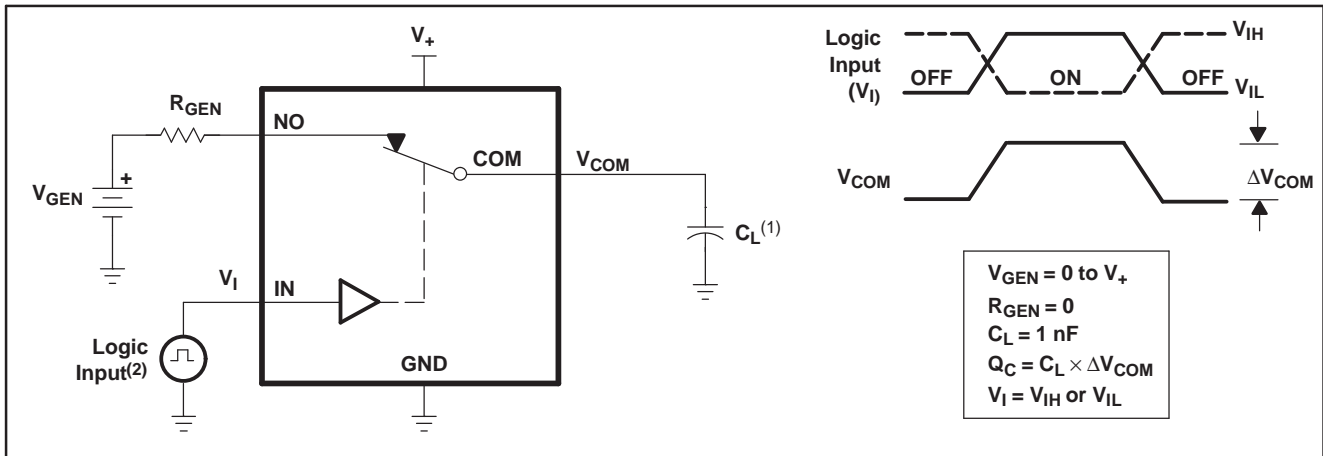

Figure 19. Crosstalk (X_{TALK})

PARAMETER MEASUREMENT INFORMATION (continued)



- (1) C_L includes probe and jig capacitance.
- (2) All input pulses are supplied by generators having the following characteristics: $PRR \leq 10 \text{ MHz}$, $Z_O = 50 \Omega$, $t_r < 5 \text{ ns}$, $t_f < 5 \text{ ns}$.

Figure 20. Charge Injection (Q_C)

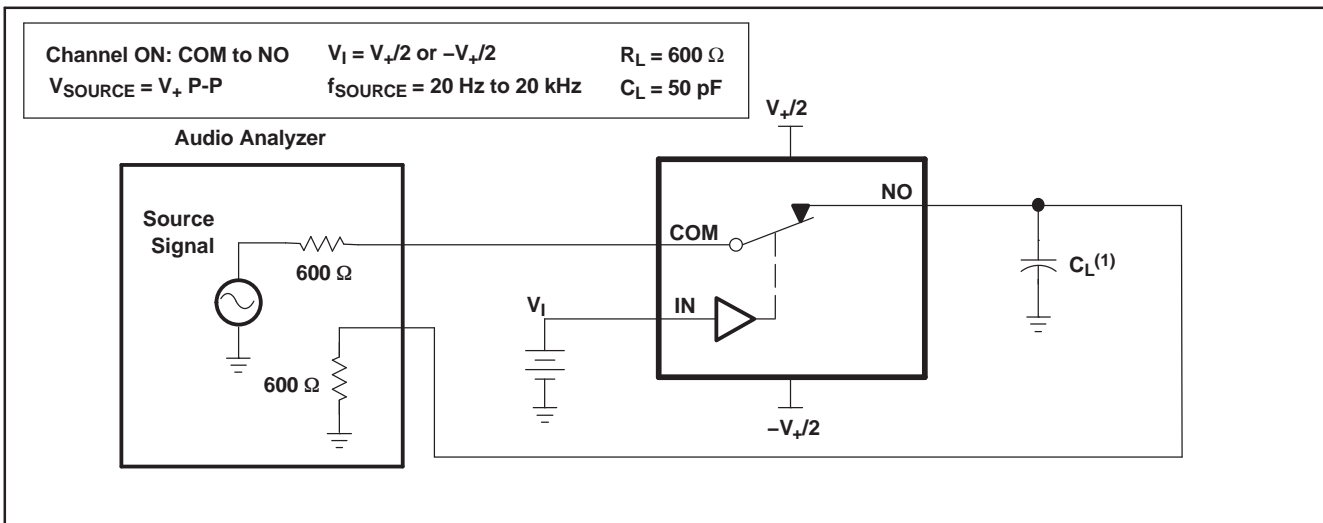

- (1) C_L includes probe and jig capacitance.

Figure 21. Total Harmonic Distortion (THD)

REVISION HISTORY

Changes from Revision F (September 2012) to Revision G	Page
• Changed pin numbers for YZT/YZP package pinout	1

PACKAGING INFORMATION

Orderable Device	Status (1)	Package Type	Package Drawing	Pins	Package Qty	Eco Plan (2)	Lead/Ball Finish (6)	MSL Peak Temp (3)	Op Temp (°C)	Device Marking (4/5)	Samples
TS5A23166DCUR	ACTIVE	US8	DCU	8	3000	Green (RoHS & no Sb/Br)	CU NIPDAU CU SN	Level-1-260C-UNLIM	-40 to 85	(AM ~ JAMR) JZ	Samples
TS5A23166DCURE4	ACTIVE	US8	DCU	8		TBD	Call TI	Call TI	-40 to 85		Samples
TS5A23166DCURG4	ACTIVE	US8	DCU	8	3000	Green (RoHS & no Sb/Br)	CU NIPDAU	Level-1-260C-UNLIM	-40 to 85	JAMR	Samples
TS5A23166YZPR	ACTIVE	DSBGA	YZP	8	3000	Green (RoHS & no Sb/Br)	SNAGCU	Level-1-260C-UNLIM	-40 to 85	(JM7 ~ JMN)	Samples
TS5A23166YZTR	ACTIVE	DSBGA	YZT	8	3000	Green (RoHS & no Sb/Br)	SNAGCU	Level-1-260C-UNLIM	-40 to 85	(JM2 ~ JM7 ~ JMN)	Samples

(1) The marketing status values are defined as follows:

ACTIVE: Product device recommended for new designs.

LIFEBUY: TI has announced that the device will be discontinued, and a lifetime-buy period is in effect.

NRND: Not recommended for new designs. Device is in production to support existing customers, but TI does not recommend using this part in a new design.

PREVIEW: Device has been announced but is not in production. Samples may or may not be available.

OBSOLETE: TI has discontinued the production of the device.

(2) Eco Plan - The planned eco-friendly classification: Pb-Free (RoHS), Pb-Free (RoHS Exempt), or Green (RoHS & no Sb/Br) - please check <http://www.ti.com/productcontent> for the latest availability information and additional product content details.

TBD: The Pb-Free/Green conversion plan has not been defined.

Pb-Free (RoHS): TI's terms "Lead-Free" or "Pb-Free" mean semiconductor products that are compatible with the current RoHS requirements for all 6 substances, including the requirement that lead not exceed 0.1% by weight in homogeneous materials. Where designed to be soldered at high temperatures, TI Pb-Free products are suitable for use in specified lead-free processes.

Pb-Free (RoHS Exempt): This component has a RoHS exemption for either 1) lead-based flip-chip solder bumps used between the die and package, or 2) lead-based die adhesive used between the die and leadframe. The component is otherwise considered Pb-Free (RoHS compatible) as defined above.

Green (RoHS & no Sb/Br): TI defines "Green" to mean Pb-Free (RoHS compatible), and free of Bromine (Br) and Antimony (Sb) based flame retardants (Br or Sb do not exceed 0.1% by weight in homogeneous material)

(3) MSL, Peak Temp. - The Moisture Sensitivity Level rating according to the JEDEC industry standard classifications, and peak solder temperature.

(4) There may be additional marking, which relates to the logo, the lot trace code information, or the environmental category on the device.

(5) Multiple Device Markings will be inside parentheses. Only one Device Marking contained in parentheses and separated by a "~" will appear on a device. If a line is indented then it is a continuation of the previous line and the two combined represent the entire Device Marking for that device.

⁽⁶⁾ Lead/Ball Finish - Orderable Devices may have multiple material finish options. Finish options are separated by a vertical ruled line. Lead/Ball Finish values may wrap to two lines if the finish value exceeds the maximum column width.

Important Information and Disclaimer:The information provided on this page represents TI's knowledge and belief as of the date that it is provided. TI bases its knowledge and belief on information provided by third parties, and makes no representation or warranty as to the accuracy of such information. Efforts are underway to better integrate information from third parties. TI has taken and continues to take reasonable steps to provide representative and accurate information but may not have conducted destructive testing or chemical analysis on incoming materials and chemicals. TI and TI suppliers consider certain information to be proprietary, and thus CAS numbers and other limited information may not be available for release.

In no event shall TI's liability arising out of such information exceed the total purchase price of the TI part(s) at issue in this document sold by TI to Customer on an annual basis.

TAPE AND REEL INFORMATION

QUADRANT ASSIGNMENTS FOR PIN 1 ORIENTATION IN TAPE

*All dimensions are nominal

Device	Package Type	Package Drawing	Pins	SPQ	Reel Diameter (mm)	Reel Width W1 (mm)	A0 (mm)	B0 (mm)	K0 (mm)	P1 (mm)	W (mm)	Pin1 Quadrant
TS5A23166DCUR	US8	DCU	8	3000	180.0	9.0	2.05	3.3	1.0	4.0	8.0	Q3
TS5A23166DCURG4	US8	DCU	8	3000	180.0	8.4	2.25	3.35	1.05	4.0	8.0	Q3
TS5A23166YZPR	DSBGA	YZP	8	3000	178.0	9.2	1.02	2.02	0.63	4.0	8.0	Q1
TS5A23166YZTR	DSBGA	YZT	8	3000	178.0	9.2	1.02	2.02	0.75	4.0	8.0	Q1

TAPE AND REEL BOX DIMENSIONS

*All dimensions are nominal

Device	Package Type	Package Drawing	Pins	SPQ	Length (mm)	Width (mm)	Height (mm)
TS5A23166DCUR	US8	DCU	8	3000	182.0	182.0	20.0
TS5A23166DCURG4	US8	DCU	8	3000	202.0	201.0	28.0
TS5A23166YZPR	DSBGA	YZP	8	3000	220.0	220.0	35.0
TS5A23166YZTR	DSBGA	YZT	8	3000	220.0	220.0	35.0

DCU (R-PDSO-G8)

PLASTIC SMALL-OUTLINE PACKAGE (DIE DOWN)

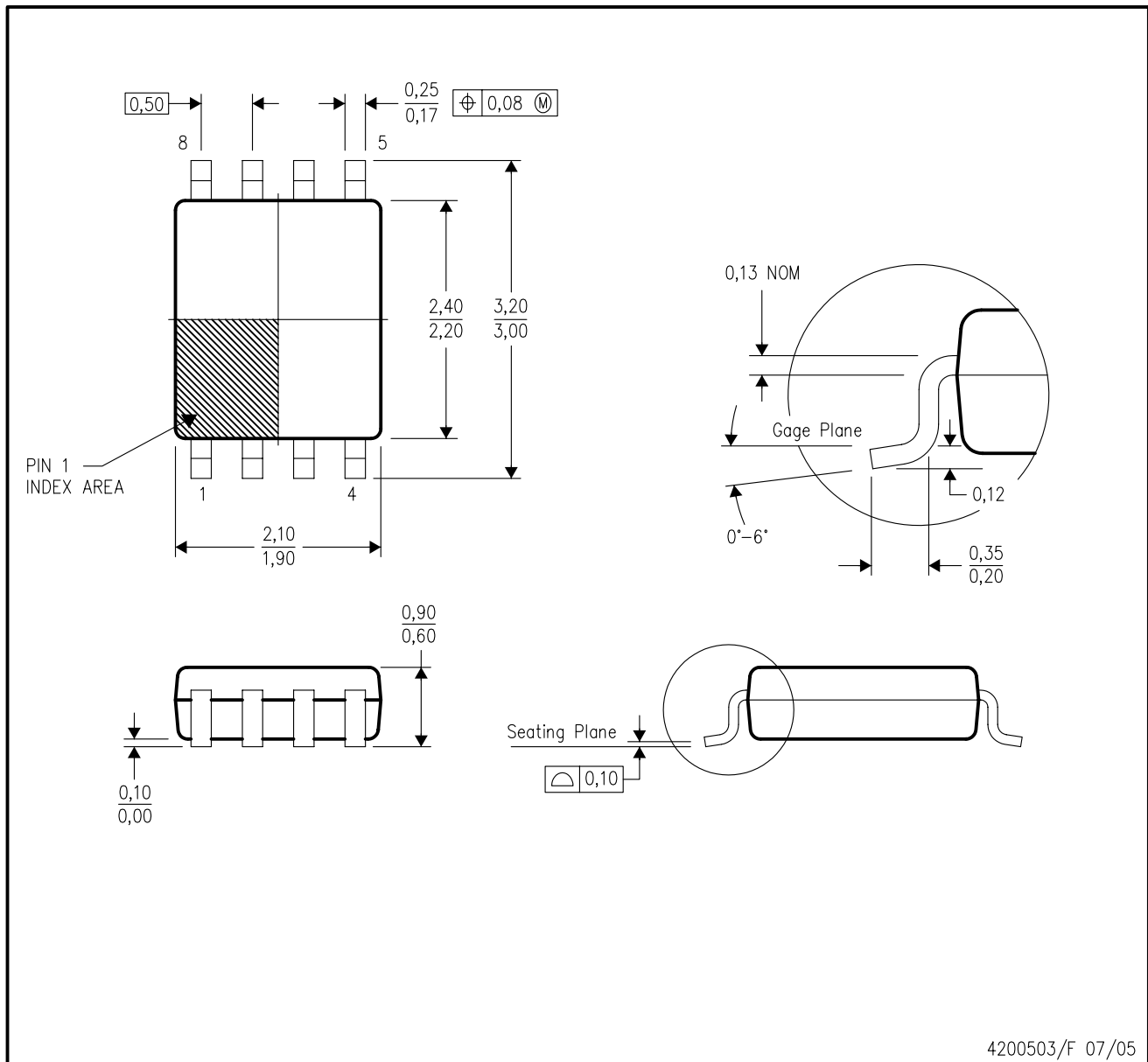

- NOTES:
- A. All linear dimensions are in millimeters.
 - B. This drawing is subject to change without notice.
 - C. Body dimensions do not include mold flash or protrusion. Mold flash and protrusion shall not exceed 0.15 per side.
 - D. Falls within JEDEC MO-187 variation CA.

DCU (S-PDSO-G8)

PLASTIC SMALL OUTLINE PACKAGE (DIE DOWN)

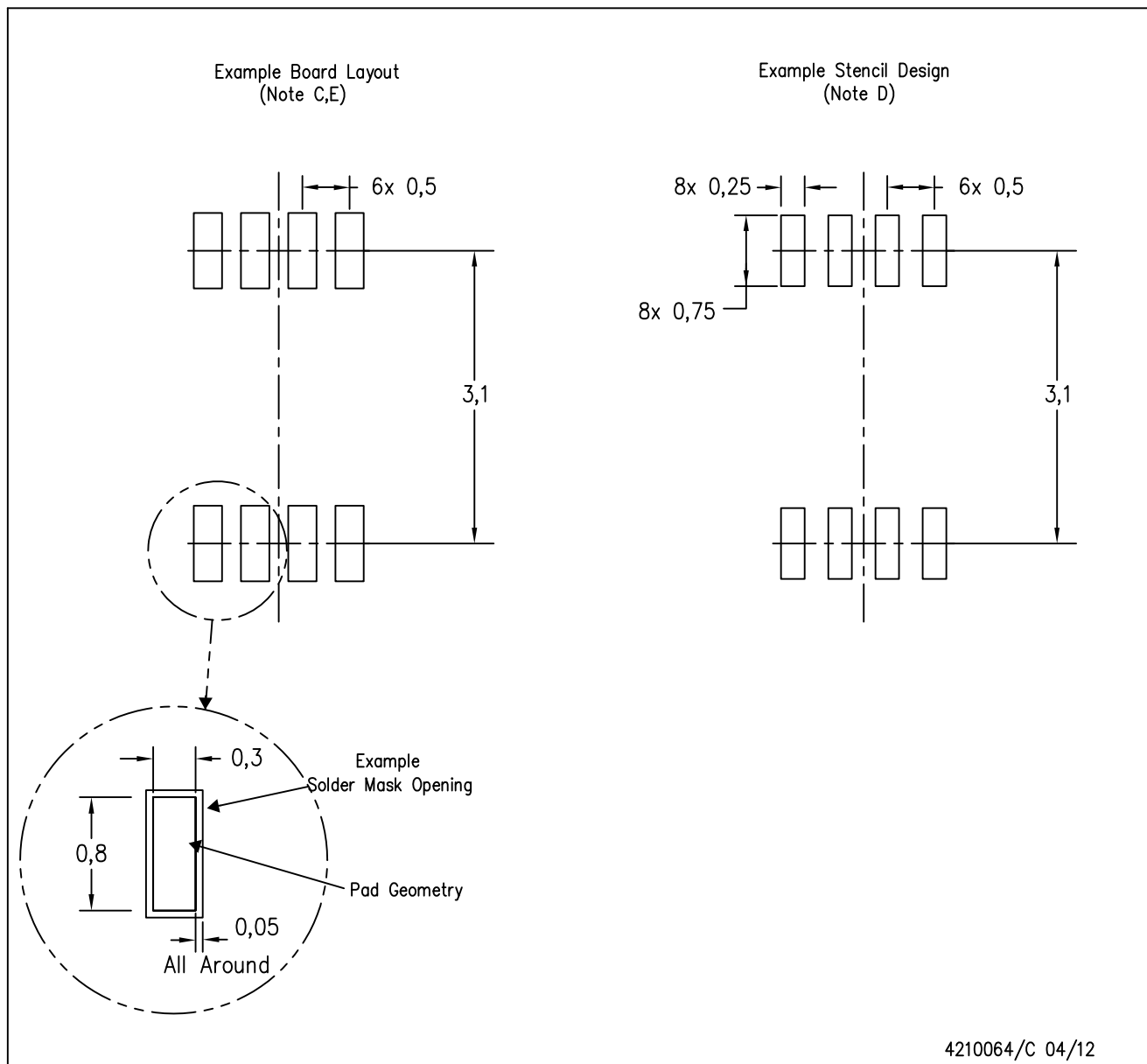

- NOTES:
- A. All linear dimensions are in millimeters.
 - B. This drawing is subject to change without notice.
 - C. Publication IPC-7351 is recommended for alternate designs.
 - D. Laser cutting apertures with trapezoidal walls and also rounding corners will offer better paste release. Customers should contact their board assembly site for stencil design recommendations. Refer to IPC-7525 for other stencil recommendations.
 - E. Customers should contact their board fabrication site for solder mask tolerances between and around signal pads.

YZP (R-XBGA-N8)

DIE-SIZE BALL GRID ARRAY

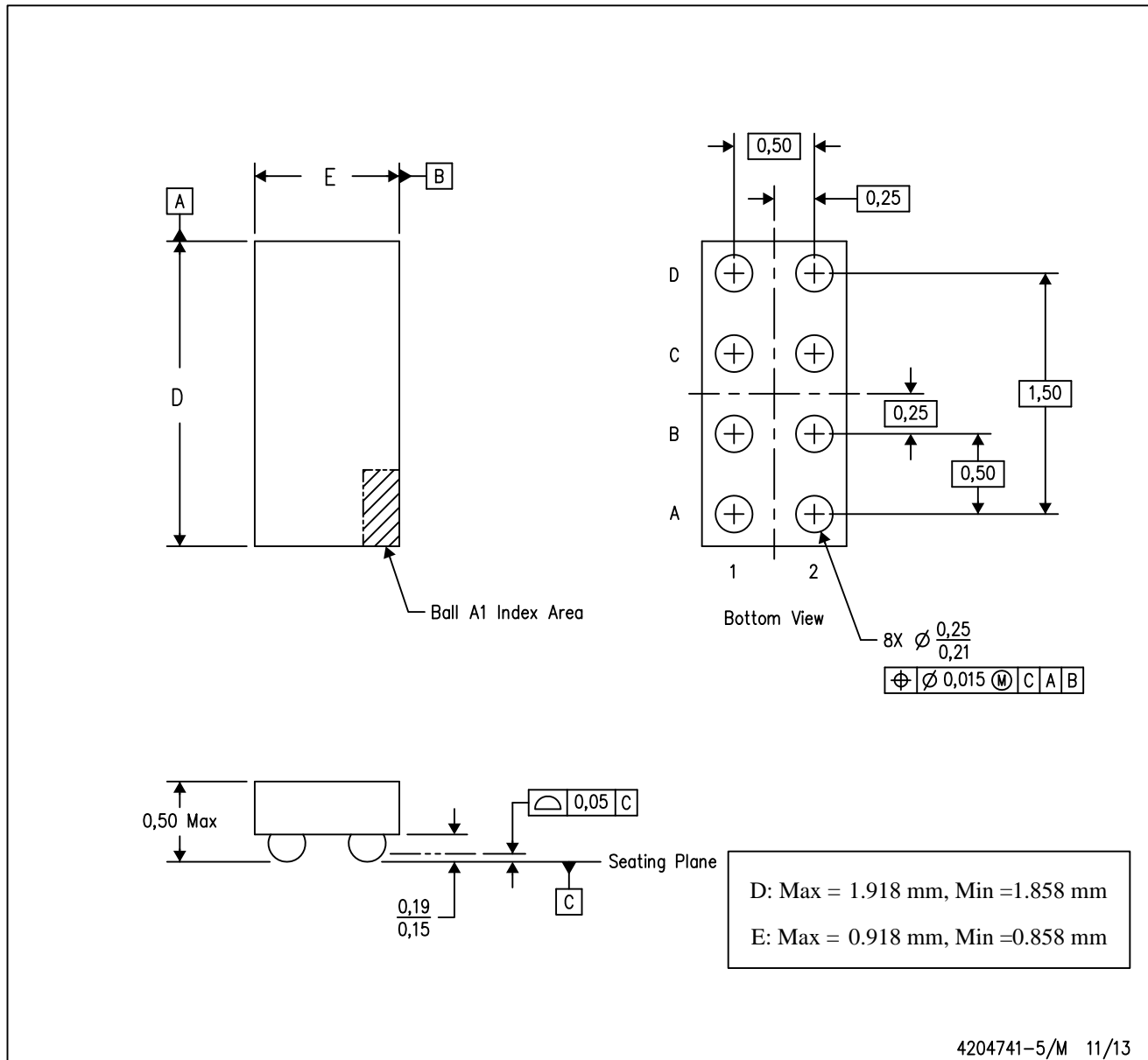

- NOTES:
- A. All linear dimensions are in millimeters. Dimensioning and tolerancing per ASME Y14.5M-1994.
 - B. This drawing is subject to change without notice.
 - C. NanoFree™ package configuration.

NanoFree is a trademark of Texas Instruments.

MECHANICAL DATA

YZT (R-XBGA-N8)

DIE-SIZE BALL GRID ARRAY

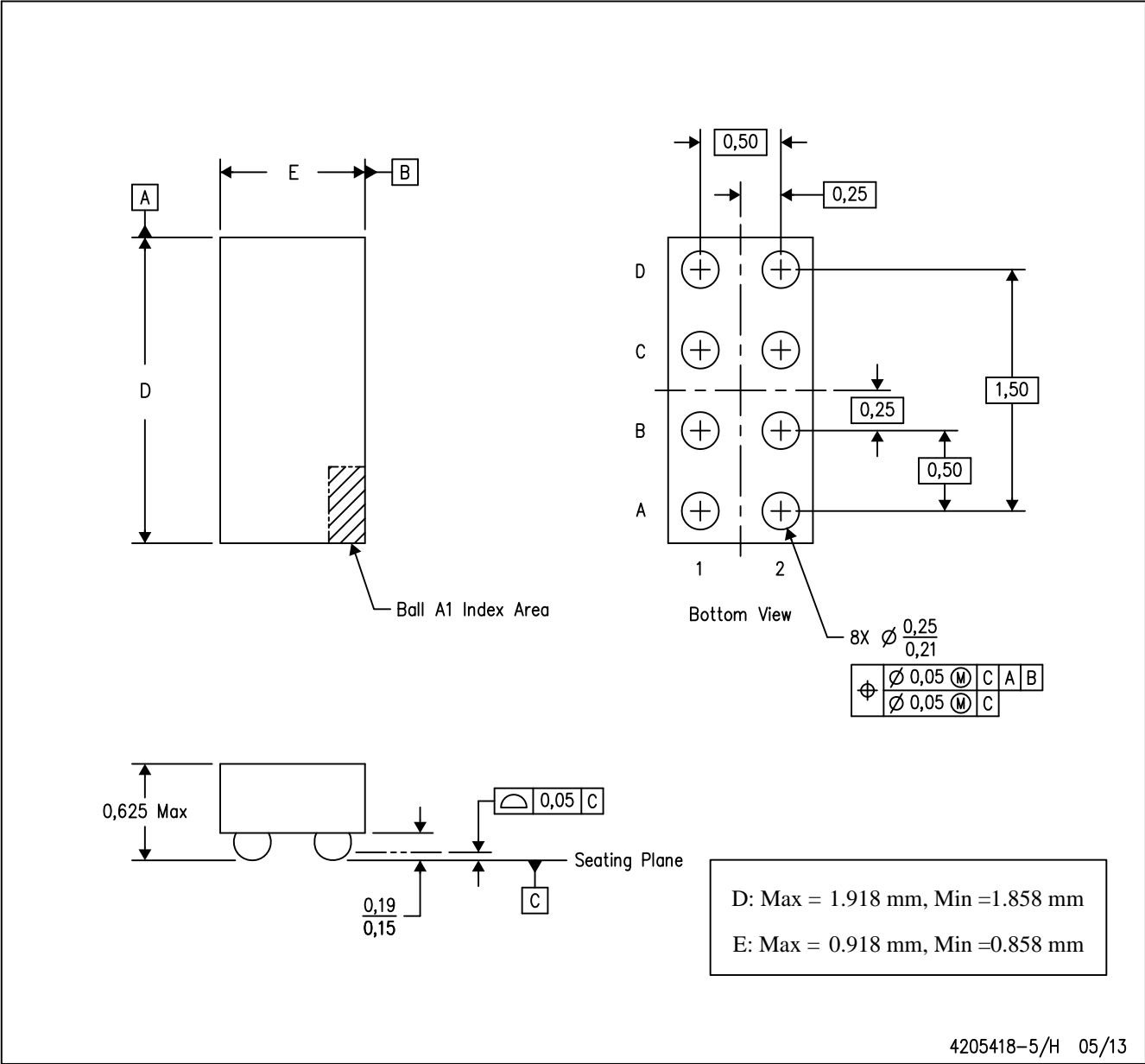

- NOTES:
- A. All linear dimensions are in millimeters. Dimensioning and tolerancing per ASME Y14.5M-1994.
 - B. This drawing is subject to change without notice.
 - C. NanoFree™ package configuration.

NanoFree is a trademark of Texas Instruments.

IMPORTANT NOTICE

Texas Instruments Incorporated and its subsidiaries (TI) reserve the right to make corrections, enhancements, improvements and other changes to its semiconductor products and services per JESD46, latest issue, and to discontinue any product or service per JESD48, latest issue. Buyers should obtain the latest relevant information before placing orders and should verify that such information is current and complete. All semiconductor products (also referred to herein as "components") are sold subject to TI's terms and conditions of sale supplied at the time of order acknowledgment.

TI warrants performance of its components to the specifications applicable at the time of sale, in accordance with the warranty in TI's terms and conditions of sale of semiconductor products. Testing and other quality control techniques are used to the extent TI deems necessary to support this warranty. Except where mandated by applicable law, testing of all parameters of each component is not necessarily performed.

TI assumes no liability for applications assistance or the design of Buyers' products. Buyers are responsible for their products and applications using TI components. To minimize the risks associated with Buyers' products and applications, Buyers should provide adequate design and operating safeguards.

TI does not warrant or represent that any license, either express or implied, is granted under any patent right, copyright, mask work right, or other intellectual property right relating to any combination, machine, or process in which TI components or services are used. Information published by TI regarding third-party products or services does not constitute a license to use such products or services or a warranty or endorsement thereof. Use of such information may require a license from a third party under the patents or other intellectual property of the third party, or a license from TI under the patents or other intellectual property of TI.

Reproduction of significant portions of TI information in TI data books or data sheets is permissible only if reproduction is without alteration and is accompanied by all associated warranties, conditions, limitations, and notices. TI is not responsible or liable for such altered documentation. Information of third parties may be subject to additional restrictions.

Resale of TI components or services with statements different from or beyond the parameters stated by TI for that component or service voids all express and any implied warranties for the associated TI component or service and is an unfair and deceptive business practice. TI is not responsible or liable for any such statements.

Buyer acknowledges and agrees that it is solely responsible for compliance with all legal, regulatory and safety-related requirements concerning its products, and any use of TI components in its applications, notwithstanding any applications-related information or support that may be provided by TI. Buyer represents and agrees that it has all the necessary expertise to create and implement safeguards which anticipate dangerous consequences of failures, monitor failures and their consequences, lessen the likelihood of failures that might cause harm and take appropriate remedial actions. Buyer will fully indemnify TI and its representatives against any damages arising out of the use of any TI components in safety-critical applications.

In some cases, TI components may be promoted specifically to facilitate safety-related applications. With such components, TI's goal is to help enable customers to design and create their own end-product solutions that meet applicable functional safety standards and requirements. Nonetheless, such components are subject to these terms.

No TI components are authorized for use in FDA Class III (or similar life-critical medical equipment) unless authorized officers of the parties have executed a special agreement specifically governing such use.

Only those TI components which TI has specifically designated as military grade or "enhanced plastic" are designed and intended for use in military/aerospace applications or environments. Buyer acknowledges and agrees that any military or aerospace use of TI components which have **not** been so designated is solely at the Buyer's risk, and that Buyer is solely responsible for compliance with all legal and regulatory requirements in connection with such use.

TI has specifically designated certain components as meeting ISO/TS16949 requirements, mainly for automotive use. In any case of use of non-designated products, TI will not be responsible for any failure to meet ISO/TS16949.

Products

Audio	www.ti.com/audio
Amplifiers	amplifier.ti.com
Data Converters	dataconverter.ti.com
DLP® Products	www.dlp.com
DSP	dsp.ti.com
Clocks and Timers	www.ti.com/clocks
Interface	interface.ti.com
Logic	logic.ti.com
Power Mgmt	power.ti.com
Microcontrollers	microcontroller.ti.com
RFID	www.ti-rfid.com
OMAP Applications Processors	www.ti.com/omap
Wireless Connectivity	www.ti.com/wirelessconnectivity

Applications

Automotive and Transportation	www.ti.com/automotive
Communications and Telecom	www.ti.com/communications
Computers and Peripherals	www.ti.com/computers
Consumer Electronics	www.ti.com/consumer-apps
Energy and Lighting	www.ti.com/energy
Industrial	www.ti.com/industrial
Medical	www.ti.com/medical
Security	www.ti.com/security
Space, Avionics and Defense	www.ti.com/space-avionics-defense
Video and Imaging	www.ti.com/video

TI E2E Community

e2e.ti.com

AMEYA360

Components Supply Platform

Authorized Distribution Brand :



Website :

Welcome to visit www.ameya360.com

Contact Us :

➤ Address :

401 Building No.5, JiuGe Business Center, Lane 2301, Yishan Rd
Minhang District, Shanghai , China

➤ Sales :

Direct +86 (21) 6401-6692

Email amall@ameya360.com

QQ 800077892

Skype [ameyasales1](#) [ameyasales2](#)

➤ Customer Service :

Email service@ameya360.com

➤ Partnership :

Tel +86 (21) 64016692-8333

Email mkt@ameya360.com