

NCP1606

Cost Effective Power Factor Controller

The NCP1606 is an active power factor controller specifically designed for use as a pre-converter in electronic ballasts, ac-dc adapters and other medium power off line converters (typically up to 300 W). It embeds a Critical Conduction Mode (CRM) scheme that substantially exhibits unity power factor across a wide range of input voltages and power levels. Housed in a DIP8 or SOIC-8 package, the NCP1606 minimizes the number of external components. Its integration of comprehensive safety protection features makes it an excellent driver for rugged PFC stages.

General Features

- “Unity” Power Factor
- No Need for Input Voltage Sensing
- Latching PWM for Cycle by Cycle On Time Control (Voltage Mode)
- High Precision Voltage Reference ($\pm 1.6\%$ over temperature ranges)
- Very Low Startup Current Consumption ($\leq 40 \mu\text{A}$)
- Low Typical Operating Current (2.1 mA)
- $-500 \text{ mA} / +800 \text{ mA}$ Totem Pole Gate Driver
- Undervoltage Lockout with Hysteresis
- Pin to Pin Compatible with Industry Standards

Safety Features

- Programmable Overvoltage Protection
- Protection against Open Loop (Undervoltage Protection)
- Accurate and Programmable On Time Limitation
- Overcurrent Limitation

Typical Applications

- Electronic Light Ballast
- AC Adapters, TVs, Monitors
- All Off Line Appliances Requiring Power Factor Correction



ON Semiconductor®

<http://onsemi.com>



**SO-8
D SUFFIX
CASE 751**

MARKING DIAGRAMS

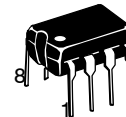
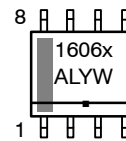

**DIP-8
P SUFFIX
CASE 626**

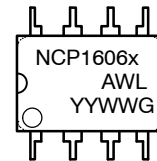

x = A or B
A = Assembly Location
L, WL = Wafer Lot
Y, YY = Year
W, WW = Work Week
▪ or G = Pb-Free Package

PIN CONNECTION

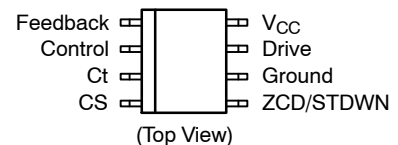

ORDERING INFORMATION

See detailed ordering and shipping information in the package dimensions section on page 20 of this data sheet.

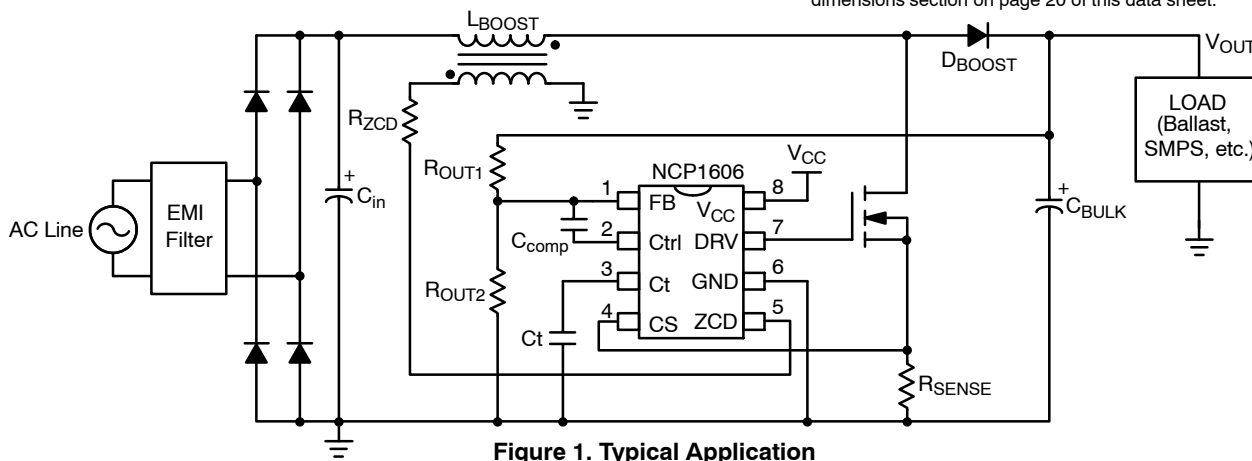

Figure 1. Typical Application

NCP1606

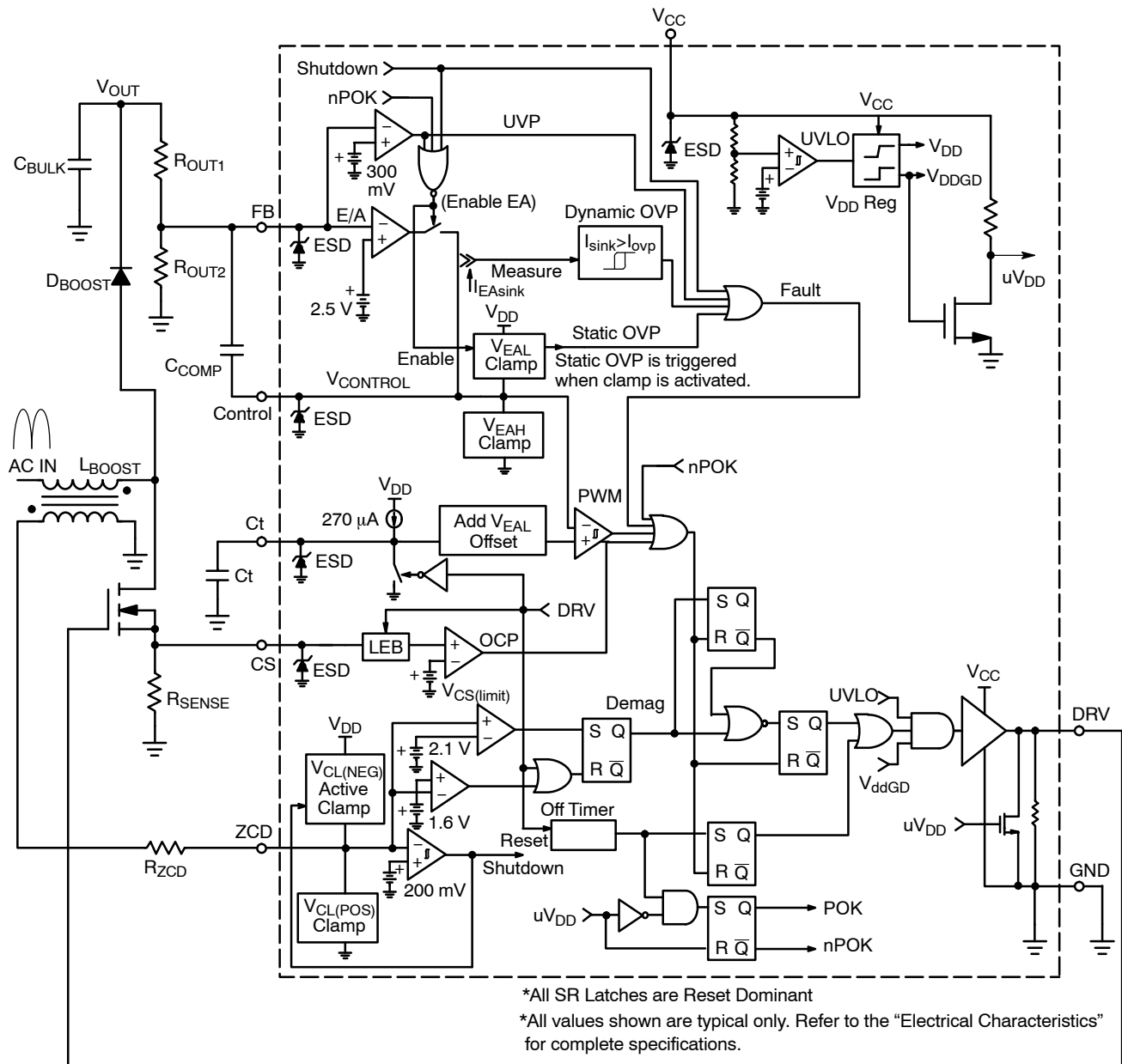

Figure 2. Block Diagram

NCP1606

PIN FUNCTION DESCRIPTION

Pin Number	Name	Function
1	Feedback (FB)	The FB pin makes available the inverting input of the internal error amplifier. A simple resistor divider scales and delivers the output voltage to the FB pin to maintain regulation. The feedback information is also used for the programmable overvoltage and undervoltage protections.
2	Control	The regulation block output is available on this pin. A compensation network is placed between FB and Control to set the loop bandwidth low enough to yield a high power factor ratio and a low THD.
3	Ct	The Ct pin sources a 270 μ A current to charge an external timing capacitor. The circuit controls the power switch on time by comparing the Ct voltage to an internal voltage derived from the regulation block.
4	Current Sense (CS)	This pin limits the pulse by pulse current through the switch MOSFET when connected as show in Figure 1. When the voltage exceeds 1.7 V (A version) or 0.5 V (B version), the drive turns off. The maximum switch current can be adjusted by changing the sense resistor.
5	Zero Current Detection (ZCD)	The voltage of an auxiliary winding should be applied to this pin to detect the moment when the coil is demagnetized for critical conduction mode operation. Ground ZCD to shutdown the part.
6	Ground (GND)	Connect this pin to the pre-converter ground.
7	Drive (DRV)	The powerful integrated driver is suitable to effectively switch a high gate charge power MOSFET.
8	V _{CC}	This pin is the positive supply of the IC. The circuit starts to operate when V _{CC} exceeds 12 V (typ) and turns off when V _{CC} goes below 9.5 V (typ). After startup, the operating range is 10.3 V to 20 V.

MAXIMUM RATINGS

Rating	Symbol	Value	Unit
Supply Voltage	V _{CC}	-0.3 to 20	V
Supply Current	I _{CC}	\pm 20	mA
DRV Voltage	V _{DRV}	-0.3 to 20	V
DRV Current	I _{DRV}	-800 to 500	mA
FB Voltage	V _{FB}	-0.3 to 10	V
FB Current	I _{FB}	\pm 10	mA
Control Voltage	V _{Control}	-0.3 to 10	V
Control Current	I _{Control}	-2 to 10	mA
Ct Voltage	V _{Ct}	-0.3 to 6	V
Ct Current	I _{Ct}	\pm 10	mA
CS Voltage	V _{CS}	-0.3 to 6	V
CS Current	I _{CS}	\pm 10	mA
ZCD Voltage	V _{ZCD}	-0.3 to 10	V
ZCD Current	I _{ZCD}	\pm 10	mA
Power Dissipation and Thermal Characteristics			
P suffix, Plastic Package, Case 626			
Maximum Power Dissipation @ T _A = 70°C	P _D (DIP)	800	mW
Thermal Resistance Junction-to-Air	R _{θJA} (DIP)	100	°C/W
D suffix, Plastic Package, Case 751			
Maximum Power Dissipation @ T _A = 70°C	P _D (SO)	450	mW
Thermal Resistance Junction-to-Air	R _{θJA} (SO)	178	°C/W
Operating Junction Temperature Range	T _J	-40 to +125	°C
Maximum Junction Temperature	T _J (MAX)	150	°C
Storage Temperature Range	T _{STG}	-65 to 150	°C
Lead Temperature (Soldering, 10 s)	T _L	300	°C

Stresses exceeding Maximum Ratings may damage the device. Maximum Ratings are stress ratings only. Functional operation above the Recommended Operating Conditions is not implied. Extended exposure to stresses above the Recommended Operating Conditions may affect device reliability.

- This device series contains ESD protection and exceeds the following tests:
 Pins 1-6, 8: Human Body Model 2000 V per JEDEC Standard JESD22-A114E,
 Machine Model Method 200 V per JEDEC Standard JESD22-A115-A
 Pin 7: Human Body Model 2000 V per JEDEC Standard JESD22-A114E,
 Machine Model Method 180 V per JEDEC Standard JESD22-A115-A
- This device contains latch-up protection and exceeds \pm 100 mA per JEDEC Standard JESD78.

NCP1606

ELECTRICAL CHARACTERISTICS

(Unless otherwise specified: For typical values, $T_J = 25^\circ\text{C}$. For min/max values, $T_J = -40^\circ\text{C}$ to $+125^\circ\text{C}$, $V_{CC} = 12\text{ V}$, $V_{FB} = 2.4\text{ V}$, $C_{DRV} = 1\text{ nF}$, $C_t = 1\text{ nF}$, $CS = 0\text{ V}$, Control = open, ZCD = open)

Symbol	Rating	Min	Typ	Max	Unit
--------	--------	-----	-----	-----	------

V_{CC} UNDERVOLTAGE LOCKOUT SECTION

$V_{CC(on)}$	V_{CC} Startup Threshold (Undervoltage Lockout Threshold, V_{CC} rising) $-25^\circ\text{C} < T_J < +125^\circ\text{C}$ $-40^\circ\text{C} < T_J < +125^\circ\text{C}$	11.0 10.9	12.0 12.0	13.0 13.1	V
$V_{CC(off)}$	V_{CC} Disable Voltage after Turn On (Undervoltage Lockout Threshold, V_{CC} falling) $-25^\circ\text{C} < T_J < +125^\circ\text{C}$ $-40^\circ\text{C} < T_J < +125^\circ\text{C}$	8.7 8.5	9.5 9.5	10.3 10.5	V
H_{UVLO}	Undervoltage Lockout Hysteresis	2.2	2.5	2.8	V

DEVICE CONSUMPTION

$I_{CC(startup)}$	Icc consumption during startup: $0\text{ V} < V_{CC} < V_{CC(on)} - 200\text{ mV}$	-	20	40	μA
I_{CC1}	Icc consumption after turn on at $V_{CC} = 12\text{ V}$, No Load, 70 kHz switching	-	1.4	2.0	mA
I_{CC2}	Icc consumption after turn on at $V_{CC} = 12\text{ V}$, 1 nF Load, 70 kHz switching	-	2.1	3	mA
$I_{CC(fault)}$	Icc consumption after turn on at $V_{CC} = 12\text{ V}$, 1 nF Load, no switching (such as during OVP fault, UVP fault, or grounding ZCD)	-	1.2	1.6	mA

REGULATION BLOCK (ERROR AMPLIFIER)

V_{REF}	Voltage Reference $@ T_J = 25^\circ\text{C}$ $-25^\circ\text{C} < T_J < +125^\circ\text{C}$ $-40^\circ\text{C} < T_J < +125^\circ\text{C}$	2.475 2.465 2.460	2.50 2.50 2.50	2.525 2.535 2.540	V
$V_{REF(line)}$	Vref Line Regulation from $V_{CC(on)} + 200\text{ mV} < V_{CC} < 20\text{ V}$, $@ T_J = 25^\circ\text{C}$	-2	-	2	mV
I_{EA}	Error Amplifier Current Capability:: (Note 3) Sink (Control = 4 V, $V_{FB} = 2.6\text{ V}$): Source (Control = 4 V, $V_{FB} = 2.4\text{ V}$):	8.0 -20	17 -6.0	30 -2	mA
G_{OL}	Open Loop, Error Amplifier Gain (Note 4)	-	80	-	dB
BW	Unity Gain Bandwidth (Note 4)	-	1	-	MHz
I_{FB}	FB Bias Current @ $V_{FB} = 3\text{ V}$	-500	-	500	nA
$I_{Control}$	Control Pin Bias Current @ $V_{FB} = 0\text{ V}$ and Control = 4.0 V.	-1	-	1	μA
V_{EAH}	$V_{CONTROL}$ @ $I_{EASOURCE} = 0.5\text{ mA}$, $V_{FB} = 2.4\text{ V}$	4.9	5.3	5.7	V
V_{EAL}	$V_{CONTROL}$ @ $I_{EASINK} = 0.5\text{ mA}$, $V_{FB} = 2.6\text{ V}$	1.85	2.1	2.4	V
$V_{EA(diff)}$	$V_{EA(diff)} = V_{EAH} - V_{EAL}$. Difference between max and min Control voltages	3.0	3.2	3.4	V

CURRENT SENSE BLOCK

$V_{CS(limit)}$	Overcurrent Protection Threshold: NCP1606A NCP1606B	1.6 0.45	1.7 0.5	1.8 0.55	V
t_{LEB}	Leading Edge Blanking duration	150	250	350	ns
t_{CS}	Overcurrent protection propagation delay.	40	100	170	ns
I_{CS}	CS bias current @ $V_{CS} = 2\text{ V}$	-1	-	1	μA

ZERO CURRENT DETECTION

V_{ZCDH}	Zero Current Detection Threshold (V_{ZCD} rising)	1.9	2.1	2.3	V
V_{ZCDL}	Zero Current Detection Threshold (V_{ZCD} falling)	1.45	1.6	1.75	V
$V_{ZCD(HYS)}$	$V_{ZCDH} - V_{ZCDL}$	300	500	800	mV
I_{ZCD}	Maximum ZCD bias Current @ $V_{ZCD} = 5\text{ V}$	-2	-	+2	μA
$V_{CL(POS)}$	Upper Clamp Voltage @ $I_{ZCD} = 2.5\text{ mA}$	5	5.7	6.5	V
$I_{CL(POS)}$	Current Capability of the Positive Clamp at $V_{ZCD} = V_{CL(POS)} + 200\text{ mV}$:	5.0	8.5	-	mA

- Parameter values are valid for transient conditions only.
- Parameter characterized and guaranteed by design, but not tested in production.

NCP1606

ELECTRICAL CHARACTERISTICS

(Unless otherwise specified: For typical values, $T_J = 25^\circ\text{C}$. For min/max values, $T_J = -40^\circ\text{C}$ to $+125^\circ\text{C}$, $V_{CC} = 12\text{ V}$, $FB = 2.4\text{ V}$, $C_{DRV} = 1\text{ nF}$, $C_t = 1\text{ nF}$, $CS = 0\text{ V}$, Control = open, ZCD = open)

Symbol	Rating	Min	Typ	Max	Unit
$V_{CL(NEG)}$	Negative Active Clamp Voltage @ $I_{ZCD} = -2.5\text{ mA}$	0.45	0.6	0.75	V
$I_{CL(NEG)}$	Current Capability of the Negative Active Clamp: in normal mode ($V_{ZCD} = 300\text{ mV}$) in shutdown mode ($V_{ZCD} = 100\text{ mV}$)	2.5 35	3.7 70	5.0 100	mA μA
V_{SDL}	Shutdown Threshold (V_{ZCD} falling)	150	200	250	mV
V_{SDH}	Enable Threshold (V_{ZCD} rising)	-	290	350	mV
V_{SDHYS}	Shutdown Comparator Hysteresis	-	90	-	mV
t_{ZCD}	Zero current detection propagation delay	-	100	170	ns
t_{SYNC}	Minimum detectable ZCD pulse width	-	70	-	ns
t_{START}	Drive off restart timer	75	180	300	μs

RAMP CONTROL

I_{CHARGE}	Charge Current ($V_{CT} = 0\text{ V}$)	$-25^\circ\text{C} < T_J < +125^\circ\text{C}$ $-40^\circ\text{C} < T_J < +125^\circ\text{C}$	243 235	270 270	297 297	μA
$t_{CT(\text{discharge})}$	Time to discharge a 1 nF C_t capacitor from $V_{CT} = 3.4\text{ V}$ to 100 mV.		-	-	100	ns
V_{CTMAX}	Maximum C_t level before DRV switches off	$-25^\circ\text{C} < T_J < +125^\circ\text{C}$ $-40^\circ\text{C} < T_J < +125^\circ\text{C}$	2.9 2.9	3.2 3.2	3.3 3.4	V
t_{PWM}	Propagation delay of the PWM comparator		-	150	220	ns

OVER AND UNDERVOLTAGE PROTECTION

I_{OVP}	Dynamic overvoltage protection (OVP) triggering current: NCP1606A NCP1606B @ $T_J = 25^\circ\text{C}$ NCP1606B @ $T_J = -40^\circ\text{C}$ to $+125^\circ\text{C}$		34 9.0 8.7	40 10.4 -	45 11.8 12.1	μA
$I_{OVP(HYS)}$	Hysteresis of the dynamic OVP current before the OVP latch is released: NCP1606A NCP1606B		- -	30 8.5	- -	μA
V_{OVP}	Static OVP Threshold Voltage			$V_{EAL} + 100\text{ mV}$		V
V_{UVP}	Undervoltage protection (UVP) threshold voltage		0.25	0.3	0.4	V

GATE DRIVE SECTION

R_{OH}	Gate Drive Resistance: R_{OH} @ $I_{SOURCE} = 100\text{ mA}$		-	12	18	Ω
R_{OL}	R_{OH} @ $I_{SOURCE} = 20\text{ mA}$ R_{OL} @ $I_{SINK} = 100\text{ mA}$ R_{OL} @ $I_{SINK} = 20\text{ mA}$		- - -	12 6 6	18 10 10	
t_{rise}	Drive voltage rise time from 10% V_{CC} to 90% V_{CC} with $C_{DRV} = 1\text{ nF}$ and $V_{CC} = 12\text{ V}$.		-	30	80	ns
t_{fall}	Drive voltage fall time from 90% V_{CC} to 10% V_{CC} with $C_{DRV} = 1\text{ nF}$ and $V_{CC} = 12\text{ V}$.		-	25	70	ns
$V_{OUT(\text{start})}$	Driver output voltage at $V_{CC} = V_{CC(\text{on})} - 200\text{ mV}$ and $I_{sink} = 10\text{ mA}$		-	-	0.2	V

- Parameter values are valid for transient conditions only.
- Parameter characterized and guaranteed by design, but not tested in production.

TYPICAL CHARACTERISTICS

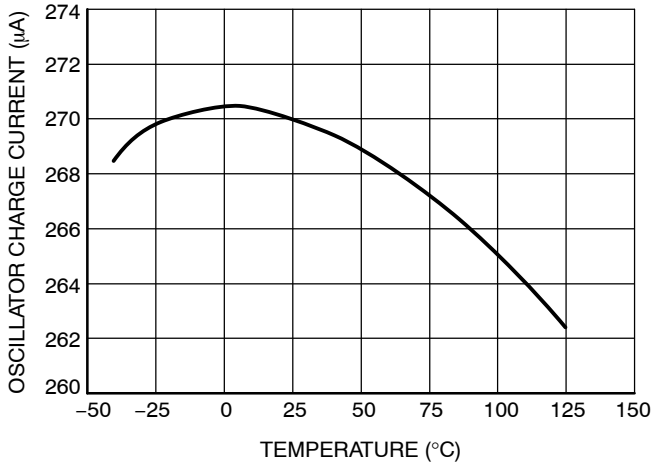

Figure 3. Oscillator Charge Current (I_{CHARGE}) vs. Temperature

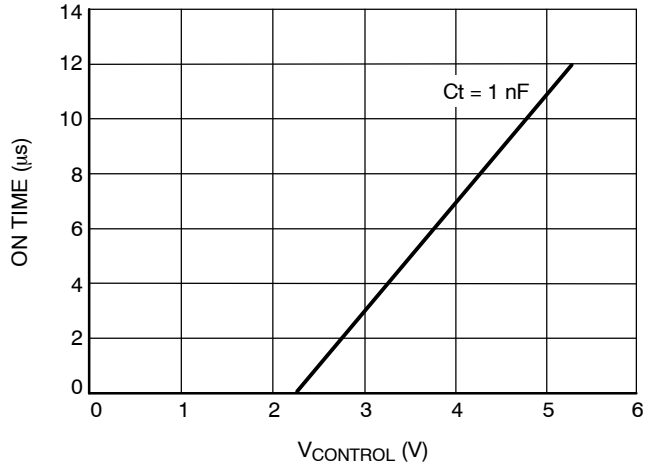

Figure 4. Typical On Time (T_{ON}) vs. $V_{CONTROL}$ Level

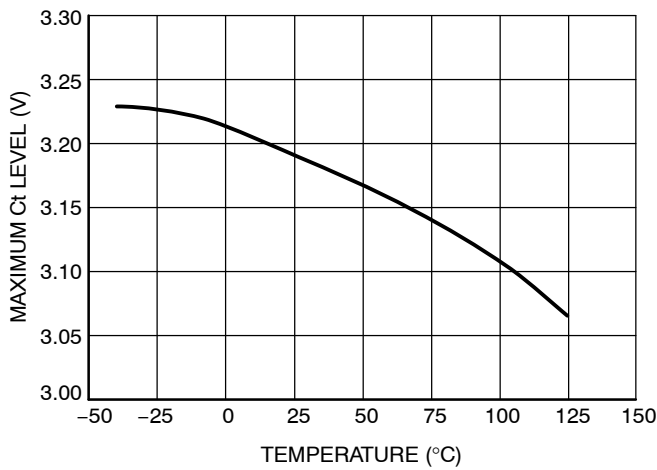

Figure 5. Maximum C_t Level (V_{CTMAX}) vs. Temperature

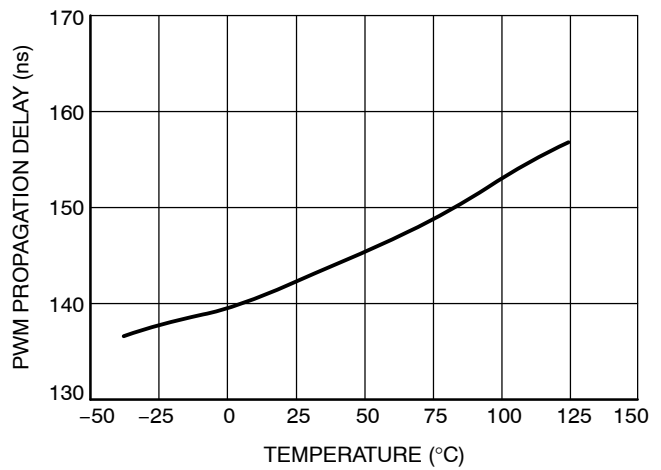

Figure 6. PWM Comparator Propagation Delay (t_{PWM}) vs. Temperature

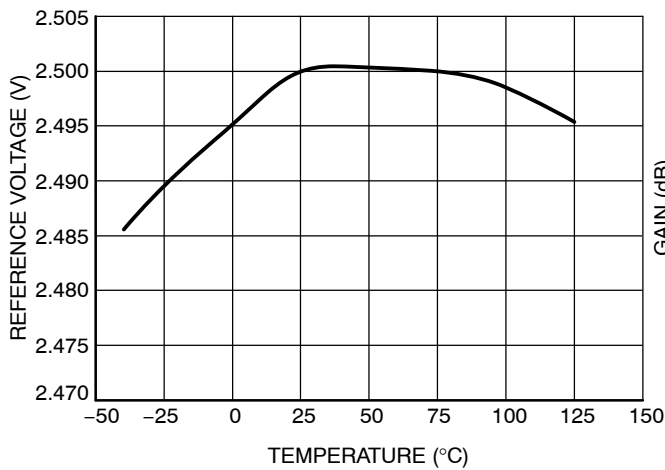

Figure 7. Reference Voltage (V_{REF}) vs. Temperature

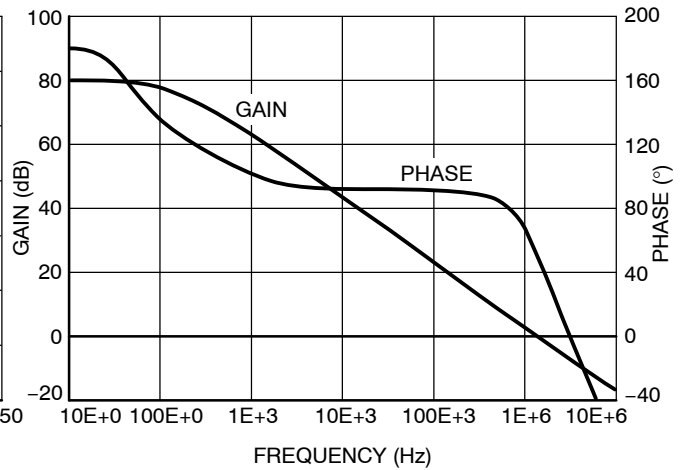

Figure 8. Error Amplifier Open Loop Gain (G_{OL}) and Phase

TYPICAL CHARACTERISTICS

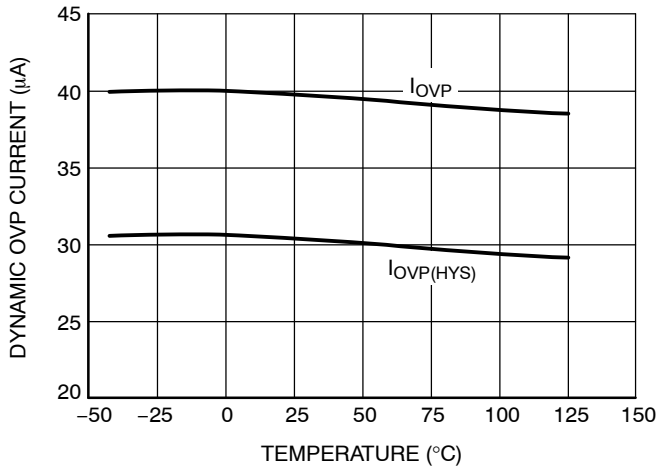

Figure 9. Overtolerance Activation Current vs. Temperature for the A Version

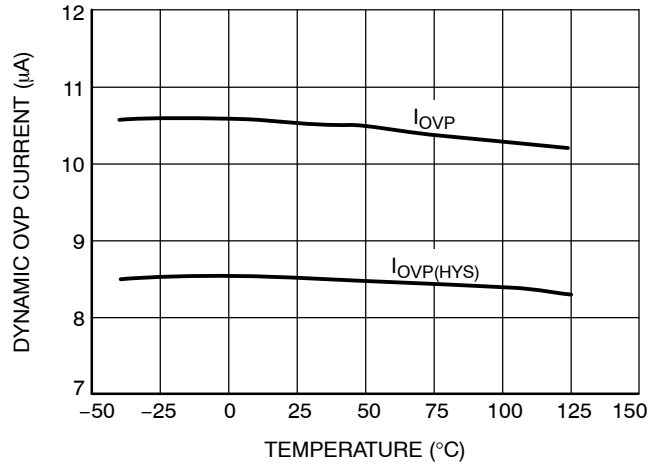

Figure 10. Overtolerance Activation Current vs. Temperature for the B Version

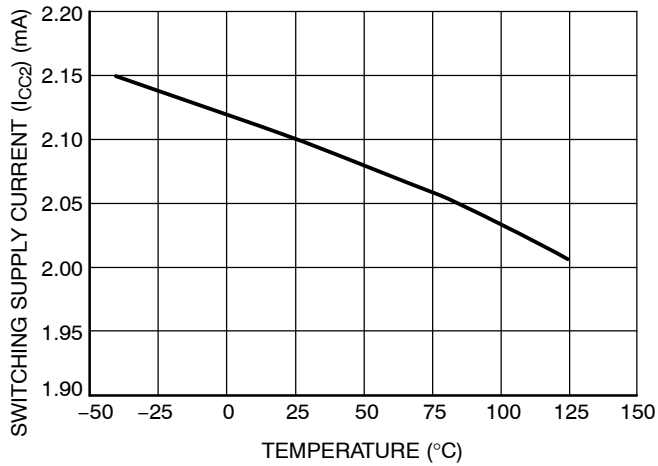

Figure 11. Supply Current (I_{CC2}) vs. Temperature

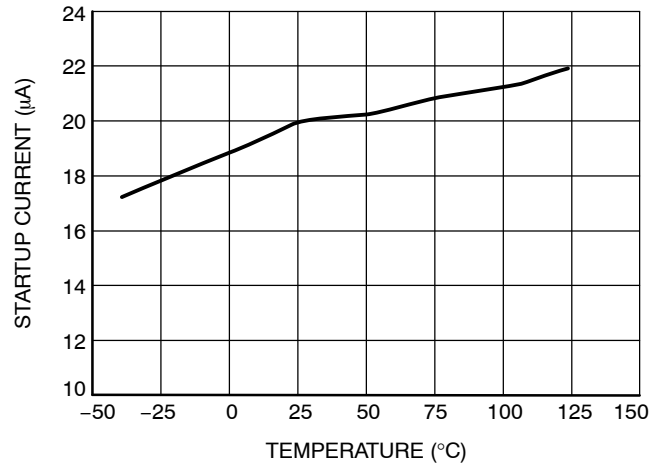

Figure 12. Startup Current $I_{CC(startup)}$ vs. Temperature

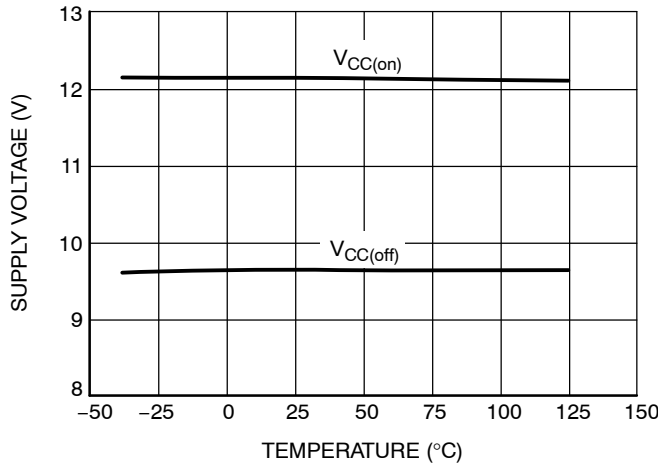

Figure 13. Supply Voltage Thresholds vs. Temperature

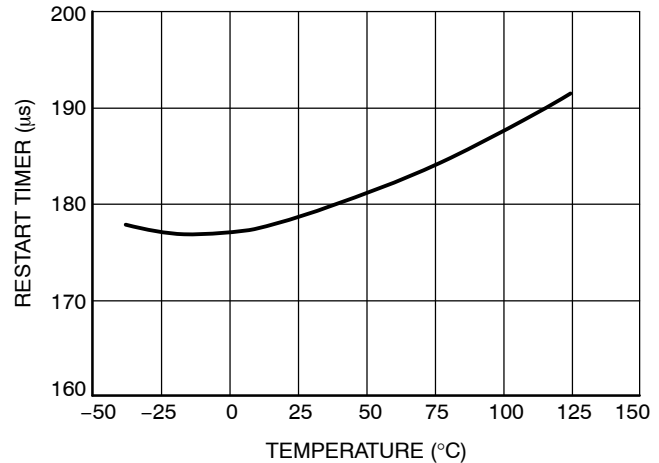

Figure 14. Restart Timer (t_{START}) vs. Temperature

NCP1606

TYPICAL CHARACTERISTICS

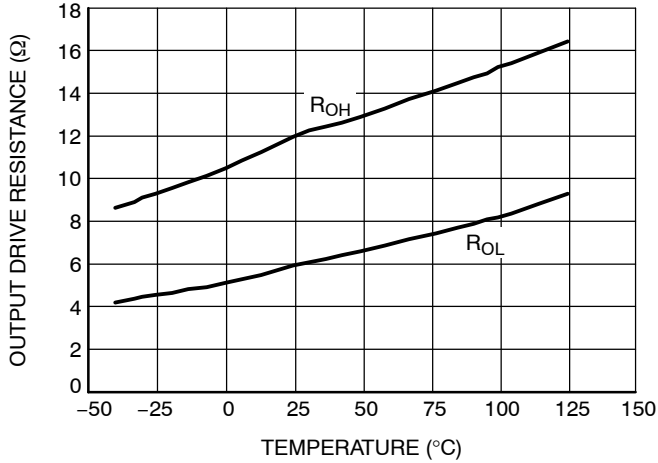

Figure 15. Output Gate Drive Resistance (R_{OH} and R_{OL}) at 100 mA vs. Temperature

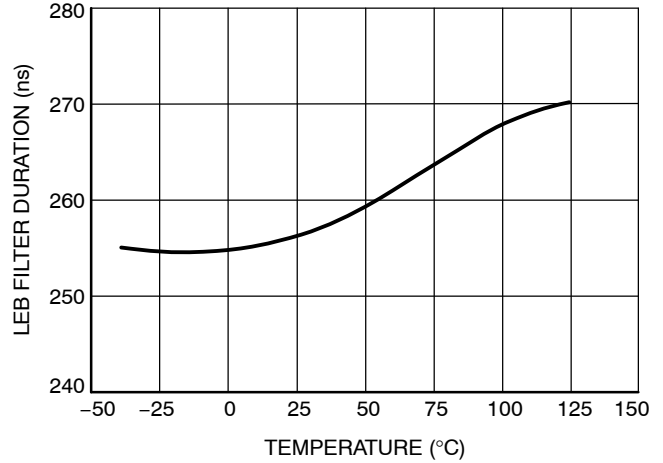

Figure 16. LEB Duration (t_{LEB}) vs. Temperature

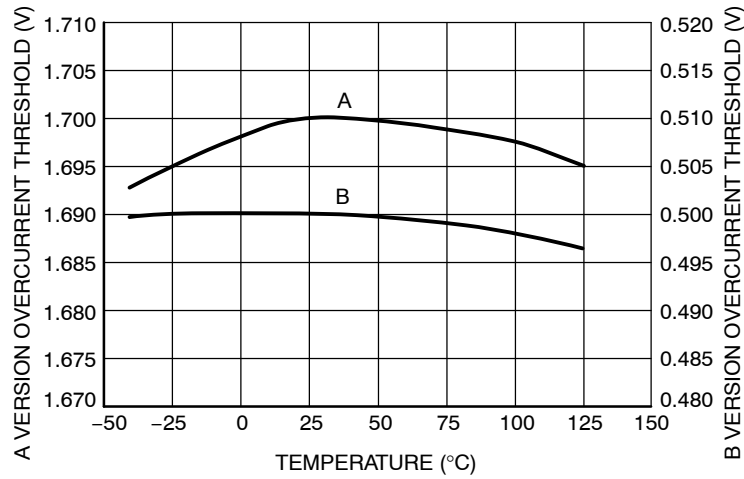

Figure 17. Overcurrent Threshold $V_{CS(limit)}$ vs. Temperature

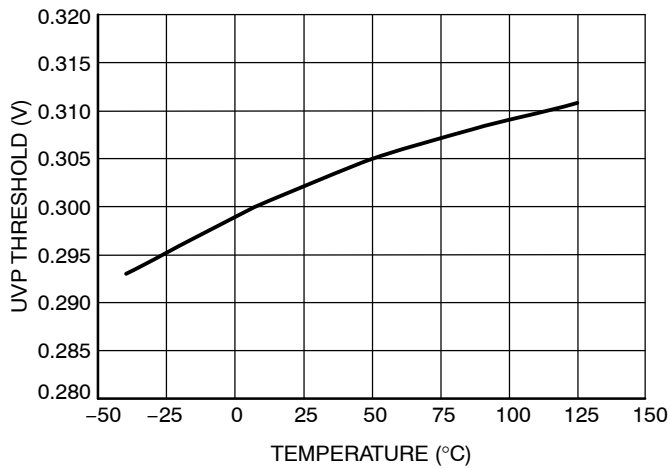

Figure 18. Undervoltage Protection Threshold (V_{UVP}) vs. Temperature

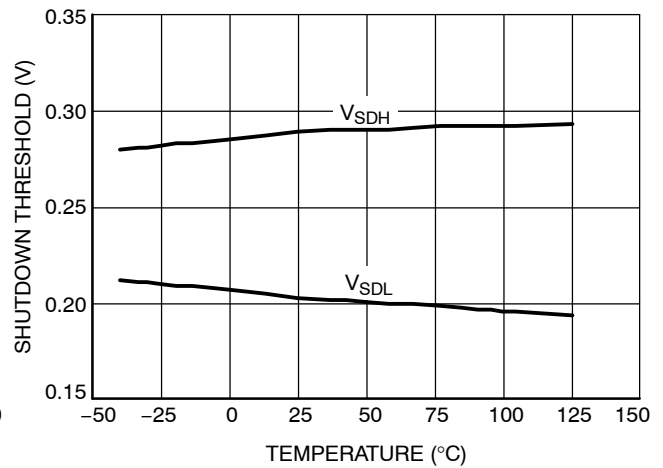

Figure 19. Shutdown Thresholds vs. Temperature

Introduction

The NCP1606 is a voltage mode power factor correction (PFC) controller designed to drive cost effective pre-converters to meet input line harmonic regulations. This controller operates in critical conduction mode (CRM) for optimal performance in applications up to about 300 W. Its voltage mode scheme enables it to obtain unity power factor without the need for a line sensing network. The output voltage is accurately controlled by a high precision error amplifier. The controller also implements a comprehensive array of safety features for robust designs. The key features of the NCP1606 are as follows:

- Constant on time (Voltage Mode) CRM operation. High power factor ratios are easily obtained without the need for input voltage sensing. This allows for optimal standby power consumption.
- Accurate and Programmable On Time Limitation. The NCP1606 using an accurate current source and an external capacitor to generate the on time.
- High Precision Voltage Reference. The error amplifier reference voltage is guaranteed at $2.5\text{ V} \pm 1.6\%$ over process and temperature. This results in very accurate output voltages.
- Very Low Startup Consumption. The circuit consumption is reduced to a minimum ($< 40\ \mu\text{A}$) during the startup phase which allows fast, low loss, charging of V_{CC} . The architecture of the NCP1606 gives a controlled undervoltage lockout level and provides ample V_{CC} hysteresis during startup.
- Powerful Output Driver. A $-500\text{ mA} / +800\text{ mA}$ totem pole gate driver is used to provide rapid turn on and turn off times. This translates into improved efficiencies and the ability to drive higher power MOSFETs. Additionally, a combination of active and passive circuitry is used to ensure that the driver output voltage does not float high while V_{CC} is below its turn on level.
- Programmable Overvoltage Protection (OVP). The adjustable OVP feature protects the PFC stage against excessive output overshoots that could damage the application. These events can typically occur during the startup phase or when the load is abruptly removed. The NCP1606B gives a lower OVP threshold, which can further reduce the application's standby power loss.
- Protection against Open Loop (Undervoltage Protection). Undervoltage protection (UVP) disables the PFC stage when the output voltage is excessively low. This also protects the circuit in case of a failure in the feedback network: if no voltage is applied to FB because of a bad connection, UVP is activated and shuts down the pre-converter.
- Overcurrent Limitation. The peak current is accurately limited on a pulse by pulse basis. The level is adjustable by modifying the switch sense resistor. The

NCP1606B uses a lower overcurrent threshold, which can further reduce the application's power dissipation. An integrated LEB filter reduces the chance of noise prematurely triggering the overcurrent limit.

- Shutdown Features. The PFC pre-converter can be easily placed in a shutdown mode by grounding either the FB pin or the ZCD pin. During this mode, the I_{CC} current consumption is reduced and the error amplifier is disabled.

Application information

Most electronic ballasts and switching power supplies use a diode bridge rectifier and a bulk storage capacitor to produce a dc voltage from the utility ac line (Figure 20). This DC voltage is then processed by additional circuitry to drive the desired output.

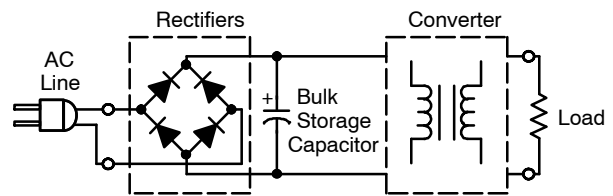

Figure 20. Typical Circuit without PFC

This simple rectifying circuit draws power from the line when the instantaneous ac voltage exceeds the capacitor voltage. Since this occurs near the line voltage peak, the resulting current draw is non sinusoidal and contains a very high harmonic content. This results in a poor power factor (typically < 0.6) and consequently, the apparent input power is much higher than the real power delivered to the load. Additionally, if multiple devices are tied to the same input line, the effect is magnified and a “line sag” effect can be produced (see Figure 21).

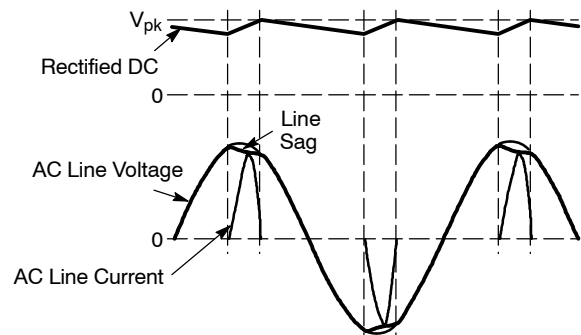

Figure 21. Typical Line Waveforms without PFC

Increasingly, government regulations and utility requirements necessitate control over the line current harmonic content. To meet this need, power factor correction is implemented with either a passive or active circuit. Passive circuits usually contain a combination of large capacitors, inductors, and rectifiers that operate at the ac line frequency. Active circuits incorporate some form of

NCP1606

a high frequency switching converter which regulates the input current to stay in phase with the input voltage. These circuits operate at a higher frequency and so they are smaller, lighter in weight, and more efficient than a passive circuit. With proper control of an active PFC stage, almost any complex load can be made to appear in phase with the

ac line, thus significantly reducing the harmonic current content. Because of these advantages, active PFC circuits have become the most popular way to meet harmonic content requirements. Generally, they consist of inserting a PFC pre-regulator between the rectifier bridge and the bulk capacitor (Figure 22).

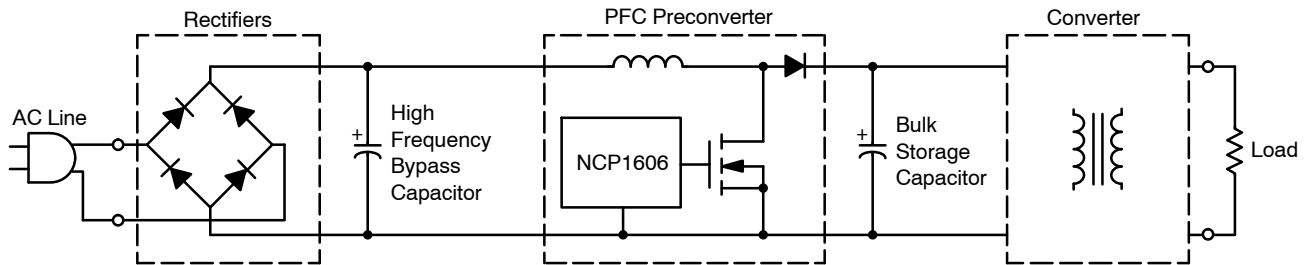

Figure 22. Active PFC Pre-Converter with the NCP1606

The boost (or step up) converter is the most popular topology for active power factor correction. With the proper control, it produces a constant voltage while drawing a sinusoidal current from the line. For medium power (<300 W) applications, critical conduction mode (also called borderline conduction mode) is the preferred control method. Critical conduction mode (CRM) occurs at the boundary between discontinuous conduction mode

(DCM) and continuous conduction mode (CCM). In CRM, the next driver on time is initiated when the boost inductor current reaches zero. CRM operation is an ideal choice for medium power PFC boost stages because it combines the lower peak currents of CCM operation with the zero current switching of DCM operation. The operation and waveforms in a PFC boost converter are illustrated in Figure 23.

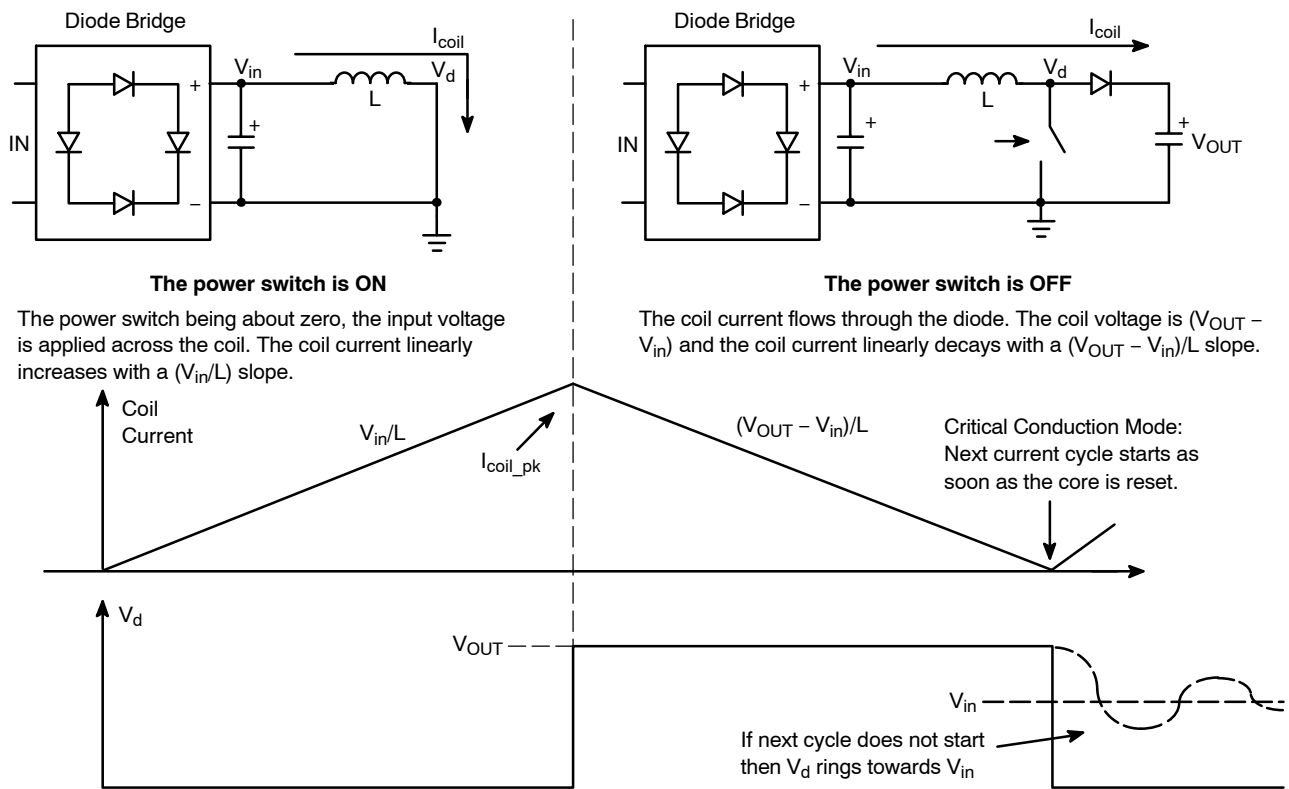

Figure 23. Schematic and Waveforms of an Ideal CRM Boost Converter

When the switch is closed, the inductor current increases linearly to its peak value. When the switch opens, the inductor current linearly decreases to zero. At this point, the drain voltage of the switch (V_d) is essentially floating and begins to drop. If the next switching cycle does not start, then the voltage will ring with a dampened frequency around V_{in} . A simple derivation of equations (such as found in AND8123), leads to the result that good power factor correction in CRM operation is achieved when the on time is constant across an ac cycle and is equal to:

$$t_{on} = \frac{2 \cdot P_{OUT} \cdot L}{\eta \cdot V_{ac_{RMS}}^2} \quad (\text{eq. 1})$$

A simple plot of this switching over an ac line cycle is illustrated in Figure 24. The off time varies based on the instantaneous line voltage, but the on time is kept constant. This naturally causes the peak inductor current (I_{Lpk}) to follow the ac line voltage.

The NCP1606 represents an ideal method to implement this constant on time CRM control in a cost effective and robust solution. The device incorporates an accurate regulation circuit, a low power startup circuit, and advanced protection features.

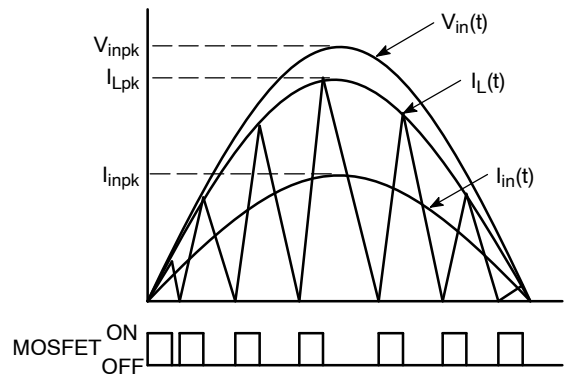

Figure 24. Inductor Waveform During CRM Operation

ERROR AMPLIFIER REGULATION

The NCP1606 is configured to regulate the boost output voltage based on its built in error amplifier (EA). The error amplifier’s negative terminal is pinned out to FB, the positive terminal is tied to a 2.5 V ± 1.6% reference, and the output is pinned out to Control (Figure 25).

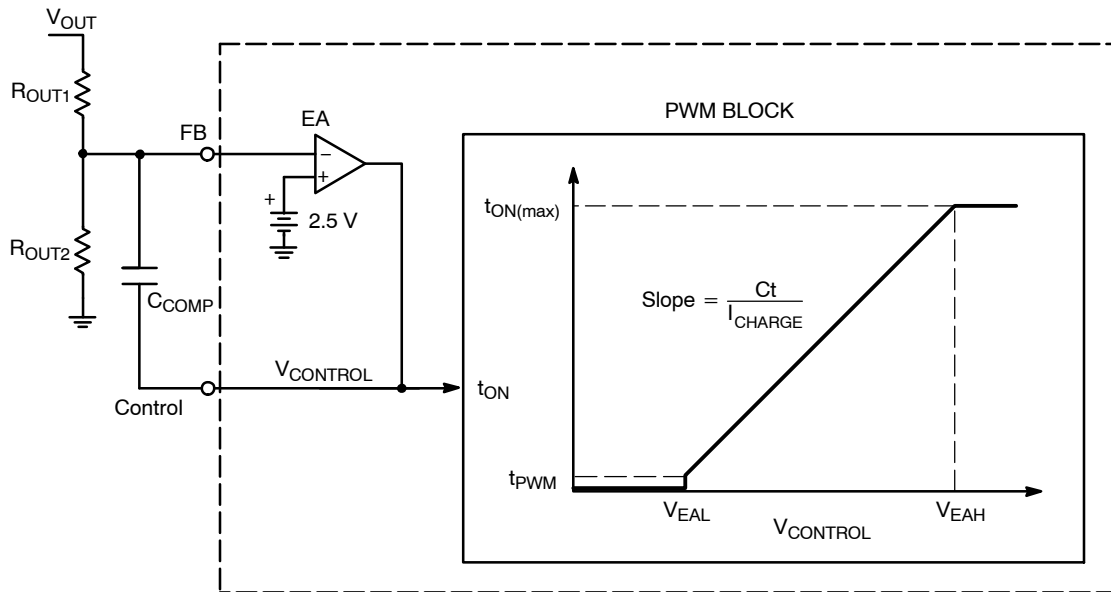

Figure 25. Error Amplifier and On Time Regulation Circuits

A resistor divider from the boost output to the input of the EA sets the FB level. If the output voltage is too low, then the FB level will drop and the EA will cause the control voltage to increase. This increases the on time of the driver, which increases the power delivered and brings the output back into regulation. Alternatively, if the output voltage (and hence FB voltage) is too high, then the control level decreases and the driver on times are shortened. In this way, the circuit regulates the output voltage (V_{OUT}) so that the V_{OUT} portion that is applied to FB through the resistor divider R_{OUT1} and R_{OUT2} is equal to the internal reference

(2.5 V). The output voltage can then be easily set according to the following equation:

$$V_{OUT} = 2.5 V \cdot \frac{R_{OUT1} + R_{OUT2}}{R_{OUT2}} \quad (\text{eq. 2})$$

A compensation network is placed between the FB and Control pins to reduce the speed at which the EA responds to changes in the boost output. This is necessary due to the nature of an active PFC circuit. The PFC stage absorbs a sinusoidal current from a sinusoidal line voltage. Hence, the converter provides the load with a power that matches

the average demand only. Therefore, the output capacitor must “absorb” the difference between the delivered power and the power consumed by the load. This means that when the power fed to the load is lower than the demand, the output capacitor discharges to compensate for the lack of

power. Alternatively, when the supplied power is higher than that absorbed by the load, the output capacitor charges to store the excess energy. The situation is depicted in Figure 26.

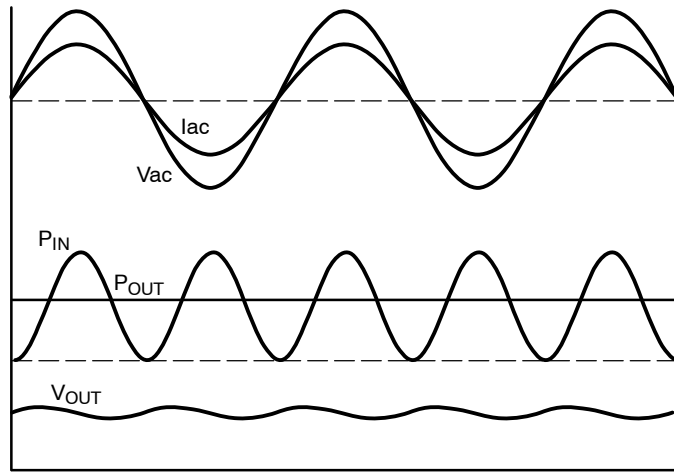

Figure 26. Output Voltage Ripple for a Constant Output Power

As a consequence, the output voltage exhibits a ripple at a frequency of either 100 Hz (for 50 Hz mains such as in Europe) or 120 Hz (for 60 Hz mains in the USA). This ripple must not be taken into account by the regulation loop because the error amplifier’s output voltage must be kept constant over a given ac line cycle for a proper shaping of the line current. Due to this constraint, the regulation bandwidth is typically set below 20 Hz. For a simple type 1 compensation network, only a capacitor is placed between FB and Control (see Figure 1). In this configuration, the capacitor necessary to attenuate the bulk voltage ripple is given by:

$$C_{COMP} = \frac{10^{\frac{G}{20}}}{4 \cdot \pi \cdot f_{line} \cdot R_{OUT1}} \quad (\text{eq. 3})$$

where G is the attenuation level in dB (commonly 60 dB)

ON TIME SEQUENCE

Since the NCP1606 is designed to control a CRM boost converter, its switching pattern must accommodate constant on times and variable off times. The Controller generates the on time via an external capacitor connected to pin 3 (Ct). A current source charges this capacitor to a level determined by the Control pin voltage. Specifically, Ct is charged to VCONTROL minus the VEAL offset (typically 2.1 V). Once this level is exceeded, the drive is turned off (Figure 27).

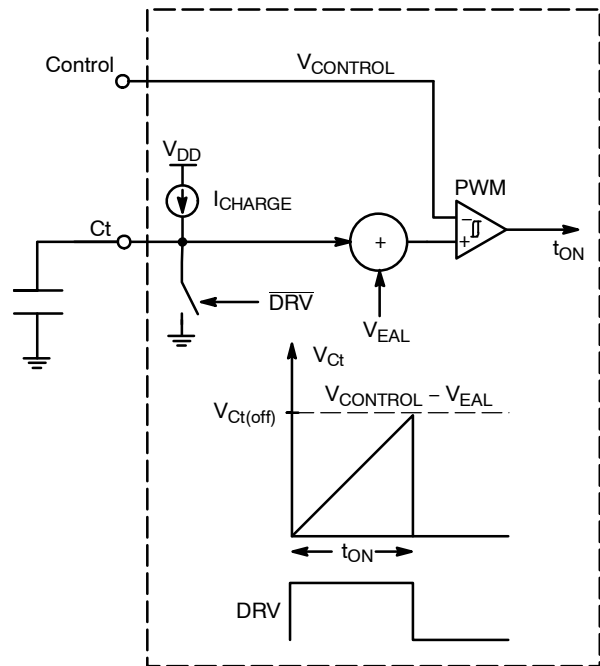

Figure 27. On Time Generation

Since VCONTROL varies with the RMS line level and output load, this naturally satisfies equation 1. And if the values of compensation components are sufficient to filter

out the bulk voltage ripple, then this on time is truly constant over the ac line cycle.

Note that the maximum on time of the controller occurs when $V_{CONTROL}$ is at its maximum. Therefore, the C_t capacitor must be sized to ensure that the required on time can be delivered at full power and the lowest input voltage condition. The maximum on time is given by:

$$t_{ON(max)} = \frac{C_t \cdot V_{CTMAX}}{I_{CHARGE}} \quad (eq. 4)$$

Combining this equation with equation 1, gives:

$$C_t \geq \frac{2 \cdot P_{OUT} \cdot L \cdot I_{CHARGE}}{\eta \cdot V_{acRMS}^2 \cdot V_{CTMAX}} \quad (eq. 5)$$

where $V_{CTMAX} = 2.9 \text{ V (min)}$

$I_{CHARGE} = 297 \mu\text{A (max)}$

OFF TIME SEQUENCE

While the on time is constant across the ac cycle, the off time in CRM operation varies with the instantaneous input voltage. The NCP1606 determines the correct off time by sensing the inductor voltage. When the inductor current drops to zero, the drain voltage (“Vd” in Figure 23) is essentially floating and naturally begins to drop. If the switch is turned on at this moment, then CRM operation will be achieved. To measure this high voltage directly on the inductor is generally not economical or practical. Rather, a smaller winding is taken off of the boost inductor. This winding, called the zero current detector (ZCD) winding, gives a scaled version of the inductor output and is more useful to the controller.

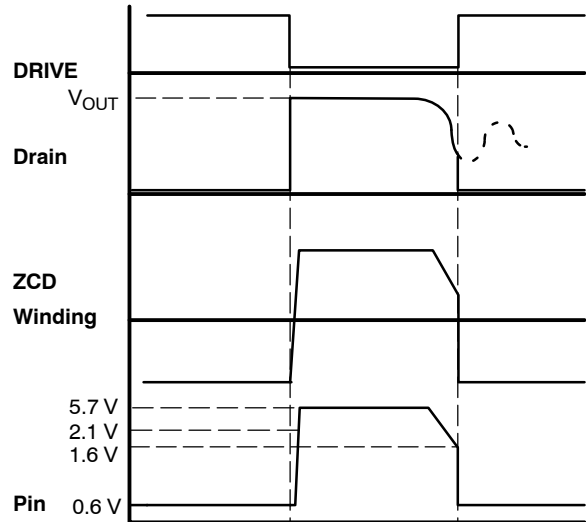

Figure 28. Voltage Waveforms for Zero Current Detection

Figure 28 gives typical operating waveforms with the ZCD winding. When the drive is on, a negative voltage appears on the ZCD winding. And when the drive is off, a positive voltage appears. When the inductor current drops to zero, then the ZCD voltage falls and starts to ring around zero volts. The NCP1606 detects this falling edge and starts the next driver on time. To ensure that a ZCD event has truly occurred, the NCP1606’s logic (Figure 29) waits for the ZCD pin voltage to rise above V_{ZCDH} (2.1 V typical) and then fall below V_{ZCDL} (1.6 V typical). In this way, CRM operation is easily achieved.

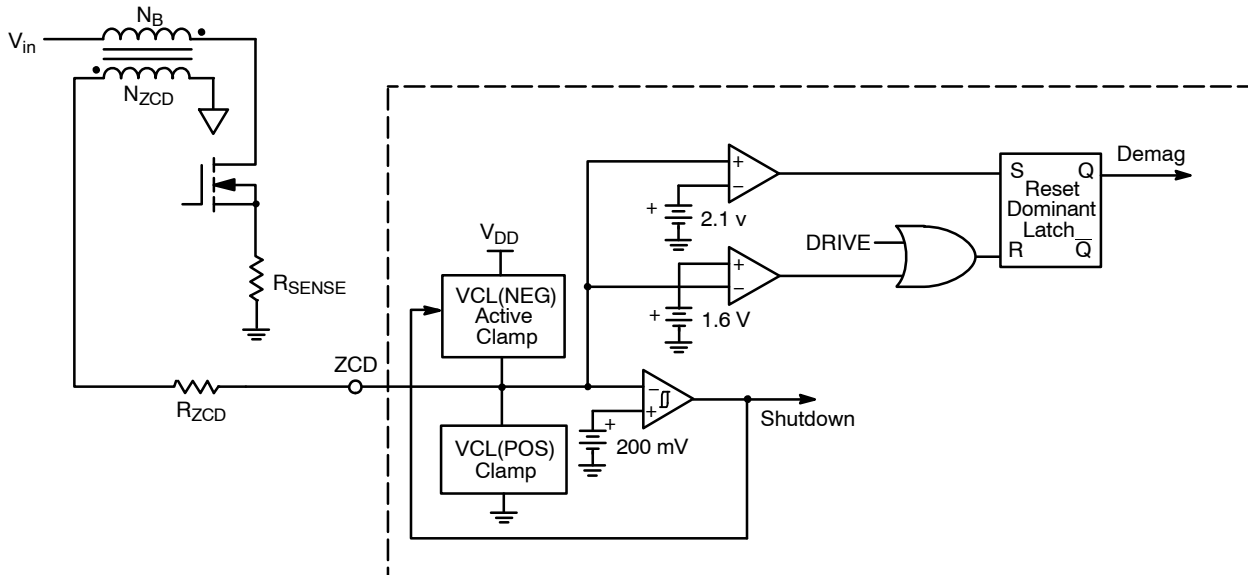

Figure 29. Implementation of the ZCD Winding

NCP1606

To prevent negative voltages on the ZCD pin, the pin is internally clamped to $V_{CL(NEG)}$ (600 mV typ) when the ZCD winding is negative. Similarly, the ZCD pin is clamped to $V_{CL(POS)}$ (5.7 V typical), when the voltage rises too high. Because of these clamps, a resistor (R_{ZCD} in Figure 29) is necessary to limit the current from the ZCD winding to the ZCD pin.

At startup, there is no energy in the ZCD winding and therefore no voltage signal to activate the ZCD comparators. This means that the driver could never turn on. Therefore, to enable the PFC stage to startup under these conditions, an internal watchdog timer is integrated into the controller. This timer turns the drive on if the driver has been off for more than 180 μ s (typical). Obviously, this feature is deactivated during a fault mode (OVP, UVP, or Shutdown), and reactivated when the fault is removed.

STARTUP

Generally, a resistor connected between the ac input and V_{CC} (pin 8) charges the V_{CC} capacitor to the $V_{CC(on)}$ level (12 V typical). Because of the very low consumption of the NCP1606 during this stage ($< 40 \mu$ A), most of the current goes directly to charging up the V_{CC} capacitor. This provides faster startup times and reduced standby power dissipation. When the V_{CC} voltage exceeds the $V_{CC(on)}$

level, the internal references and logic of the NCP1606 turn on. The controller has an undervoltage lockout (UVLO) feature which keeps the part active until V_{CC} drops below $V_{CC(off)}$ (9.5 V typical). This hysteresis allows ample time for the auxiliary winding to take over and supply the necessary power to V_{CC} (Figure 30).

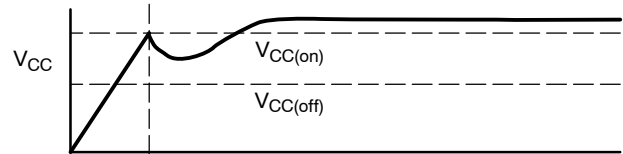

Figure 30. Typical V_{CC} Startup Waveform

When the PFC pre-converter is loaded by a switch mode power supply (SMPS), then it is often preferable to have the SMPS controller startup first. The SMPS can then supply the NCP1606 V_{CC} directly. Advanced controllers, such as the NCP1230 or NCP1381, can control when to turn on the PFC stage (see Figure 31) leading to optimal system performance. This setup also eliminates the startup resistors and therefore improves the no load power dissipation of the system.

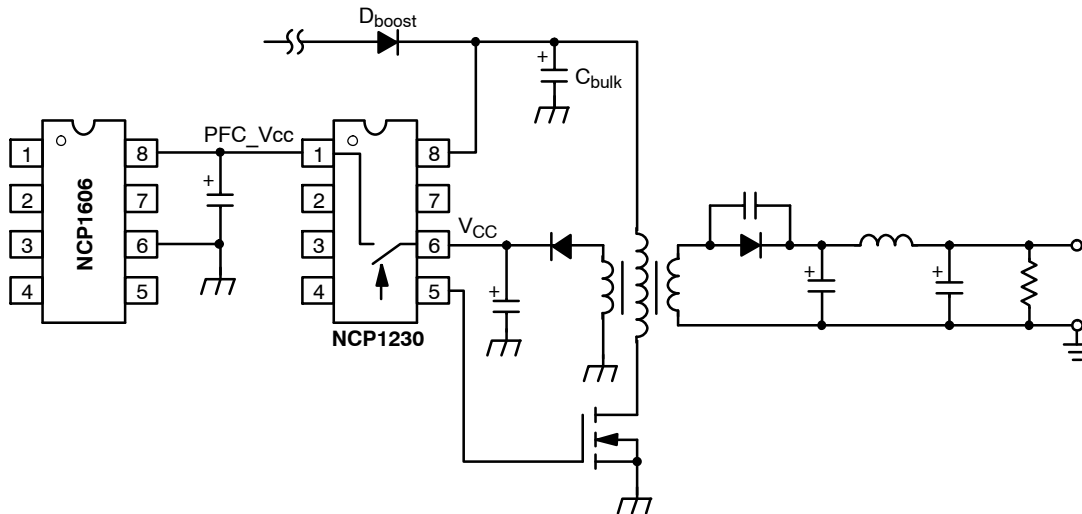

Figure 31. NCP1606 Supplied by a Downstream SMPS Controller (NCP1230)

QUICK START and SOFT START

At startup, the error amplifier is enabled and Control is pulled up to V_{EAL} (typically 2.1 V). This is the lowest level of control voltage which produces output drives. This feature, called “quick start,” eliminates the delay at startup

associated with charging the compensation network to its minimum level. This also produces a natural “soft start” mode where the controller’s power ramps up from zero to the required power (see Figure 32).

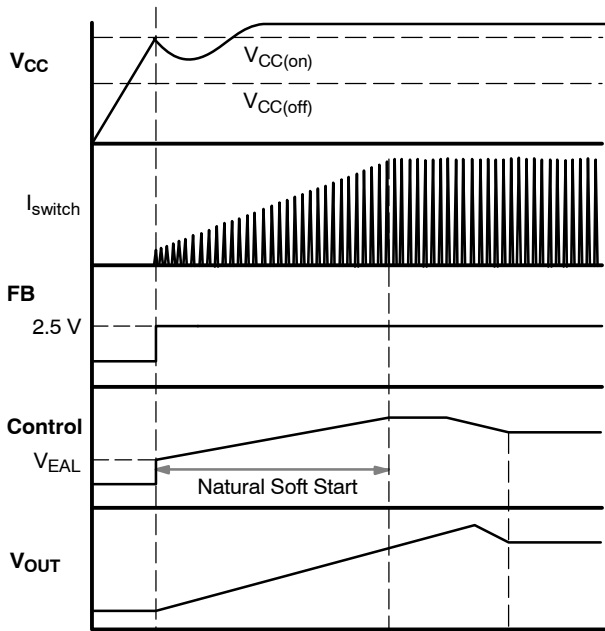

Figure 32. Startup Timing Diagram Showing the Natural Soft Start of the Control Pin

OUTPUT DRIVER

The NCP1606 includes a powerful output driver capable of peak currents of +500 mA and -800 mA. This enables the controller to efficiently drive power MOSFETs for medium power (up to 300 W) applications. Additionally, the driver stage is equipped with both passive and active pull down clamps (Figure 33). The clamps are active when V_{CC} is off and force the driver output to well below the threshold voltage of a power MOSFET.

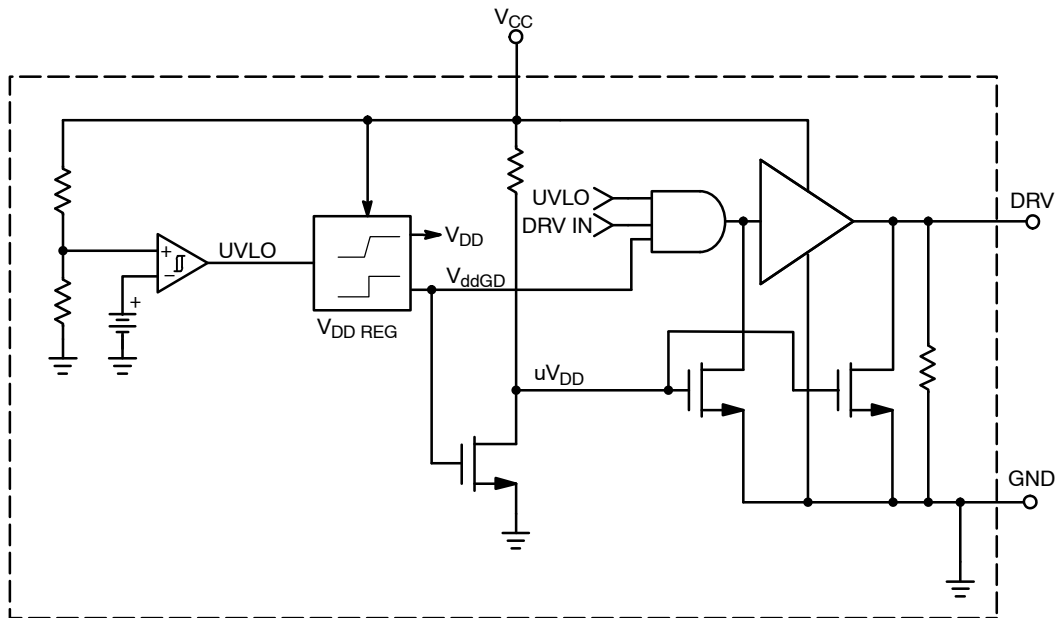

Figure 33. Output Driver Stage and Pull Down Clamps

Overvoltage Protection

The low bandwidth of the feedback network makes active PFC stages very slow systems. One consequence of this is the risk of huge overshoots in abrupt transient phases (startup, load steps, etc.). For reliable operation, it is critical that some form of overvoltage protection (OVP) effectively prevents the output voltage from rising too high. The NCP1606 detects these excessive V_{OUT} levels

and disables the driver until the output voltage returns to nominal levels. This keeps the output voltage within an acceptable range. The limit is adjustable so that the overvoltage level can be optimally set. The level must not be so low that it is triggered by the 100 or 120 Hz ripple of the output voltage. But it must be low enough so as not to require a larger voltage rating of the output capacitor. Figure 34 depicts the operation of the OVP circuitry.

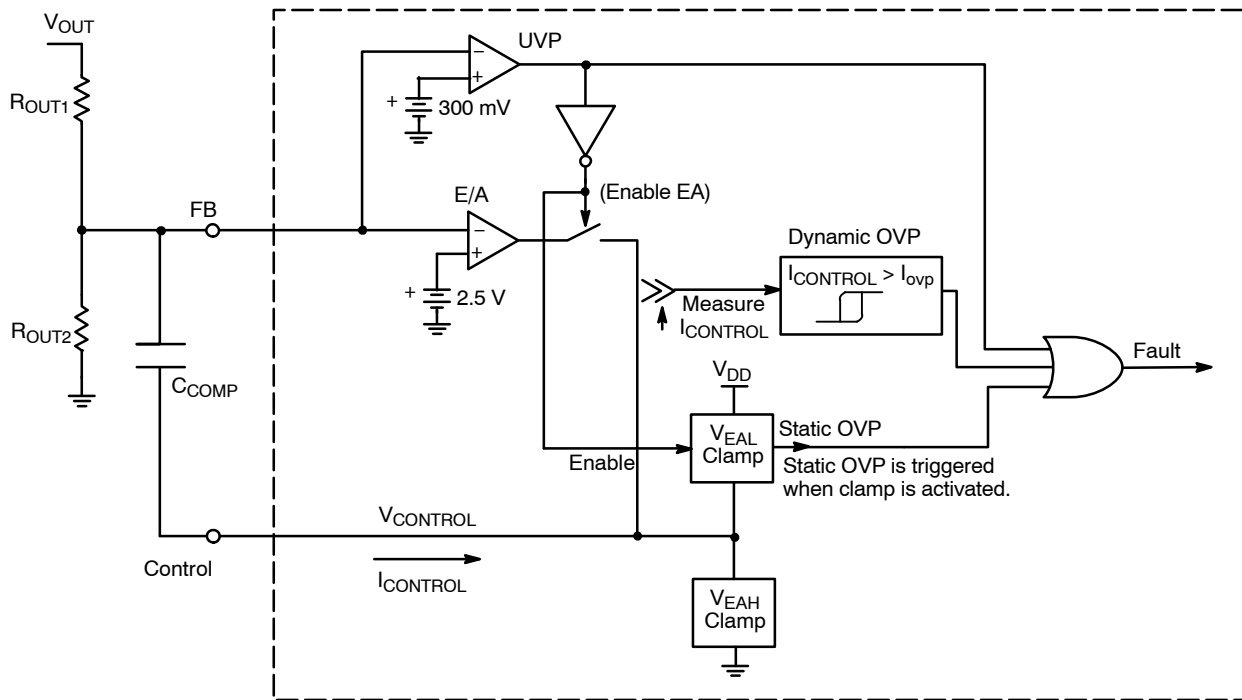

Figure 34. OVP and UVP Circuit Blocks

When the output voltage is in steady state, R_{OUT1} and R_{OUT2} regulate the FB voltage to 2.5 V. Also, during this equilibrium state, no current flows through the compensation capacitor (“ C_{COMP} ” of Figure 1). Therefore:

- The R_{OUT1} current is:

$$I_{R_{OUT1}} = \frac{(V_{OUT})_{nom} - 2.5 V}{R_{OUT1}} \quad (\text{eq. 6})$$

where $(V_{OUT})_{nom}$ is the nominal output voltage.

- The R_{OUT2} current is:

$$I_{R_{OUT2}} = \frac{2.5 V}{R_{OUT2}} \quad (\text{eq. 7})$$

- And since no current flows through C_{COMP}

$$I_{R_{OUT1}} = I_{R_{OUT2}} \Rightarrow \frac{(V_{OUT})_{nom} - 2.5 V}{R_{OUT1}} = \frac{2.5 V}{R_{OUT2}} \quad (\text{eq. 8})$$

Under stable conditions, these equations are true. Conversely when V_{OUT} is not at its nominal level, the output of the error amplifier sinks or sources the current necessary to maintain 2.5 V on pin 1. In particular, in the case of an overvoltage condition:

- The error amplifier maintains 2.5 V on pin 1, and the R_{OUT2} current remains:

$$I_{R_{OUT2}} = \frac{2.5 V}{R_{OUT2}} \quad (\text{eq. 9})$$

- The R_{OUT1} current is:

$$(\text{eq. 10})$$

$$I_{R_{OUT1}} = \frac{V_{OUT} - 2.5 V}{R_{OUT1}} = \frac{(V_{OUT})_{nom} + \Delta V_{OUT} - 2.5 V}{R_{OUT1}}$$

where ΔV_{OUT} is the output voltage excess.

- Therefore, the error amplifier sinks:

$$(\text{eq. 11})$$

$$I_{R_{OUT1}} - I_{R_{OUT2}} = \frac{(V_{OUT})_{nom} + \Delta V_{OUT} - 2.5 V}{R_{OUT1}} - \frac{2.5 V}{R_{OUT2}}$$

The combination of Equations 2 and 11 leads to a very simple expression of the current sunk by the error amplifier:

$$I_{CONTROL} = I_{R_{OUT1}} - I_{R_{OUT2}} = \frac{\Delta V_{OUT}}{R_{OUT1}} \quad (\text{eq. 12})$$

Hence, the current absorbed by pin 2 ($I_{CONTROL}$) is proportional to the output voltage excess. The circuit senses this current and disables the drive (pin 7) when $I_{CONTROL}$ exceeds I_{OVP} (typically 40 μA in NCP1606A, 10.4 μA in NCP1606B). This gives the OVP threshold as:

$$(V_{OUT})_{OVP} = (V_{OUT})_{nom} + (R_{OUT1} \cdot I_{OVP})$$

By simply adjusting R_{OUT1} , the OVP limit can be easily set. Therefore, one can compute the R_{OUT1} and R_{OUT2} resistances using the following procedure:

1. Select R_{OUT1} to set the desired overvoltage level:

$$R_{OUT1} = \frac{(V_{OUT})_{OVP} - (V_{OUT})_{nom}}{I_{OVP}}$$

For instance if implementing the NCP1606B, and 420 V is the maximum output level and 400 V is the nominal output level, then

$$R_{OUT1} = \frac{420 - 400}{10.4 \mu A} = 1.9 M\Omega$$

2. Select R_{OUT2} to adjust the regulation level:

$$R_{OUT2} = \frac{2.5 V \cdot R_{OUT1}}{V_{OUT(nom)} - 2.5 V}$$

For the above example, this leads to:

$$R_{OUT2} = \frac{2.5 \text{ V}}{400 \text{ V} - 2.5 \text{ V}} \cdot 1.9 \text{ M}\Omega = 12.0 \text{ k}\Omega.$$

STATIC OVERVOLTAGE PROTECTION

If the OVP condition lasts for a long time, it may happen that the error amplifier output reaches its minimum level (i.e. Control = V_{EAL}). It would then not be able to sink any current and maintain the OVP fault. Therefore, to avoid any discontinuity in the OVP disabling effect, the circuit incorporates a comparator which detects when the lower level of the error amplifier is reached. This event, called “static OVP”, disables the output drives. Once the OVP event is over, and the output voltage has dropped to normal, then Control rises above the lower limit and the driver is re-enabled (Figure 35).

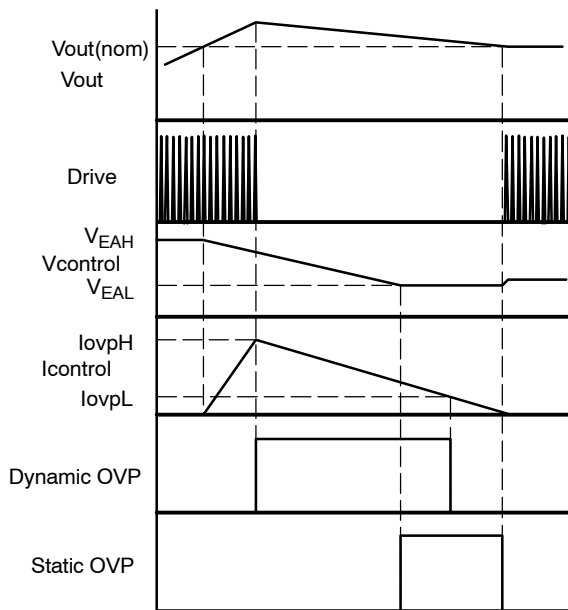

Figure 35. OVP Timing Diagram

NCP1606 Undervoltage Protection (UVP)

When the PFC stage is plugged in, the output voltage is forced to roughly equate the peak line voltage. The NCP1606 detects an undervoltage fault when this output voltage is unusually low, such that the feedback voltage is below V_{UVP} (300 mV typ). In an UVP fault, the drive output and error amplifier (EA) are disabled. The latter is done so that the EA does not source a current which would increase the FB voltage and prevent the UVP event from being accurately detected. The UVP feature helps to protect the application if something is wrong with the power path to the bulk capacitor (i.e. the capacitor cannot charge up) or if the controller cannot sense the bulk voltage (i.e. the feedback loop is open).

Furthermore, the NCP1606 incorporates a novel startup sequence which ensures that undervoltage conditions are always detected at startup. It accomplishes this by waiting approximately 180 μ s after V_{CC} reaches $V_{CC(on)}$ before enabling the error amplifier (Figure 36). During this wait time, it looks to see if the feedback (FB) voltage is greater than the UVP threshold. If not, then the controller enters a UVP fault and leaves the error amplifier disabled. However, if the FB pin voltage increases and exceeds the UVP level, then the controller will start the application up normally.

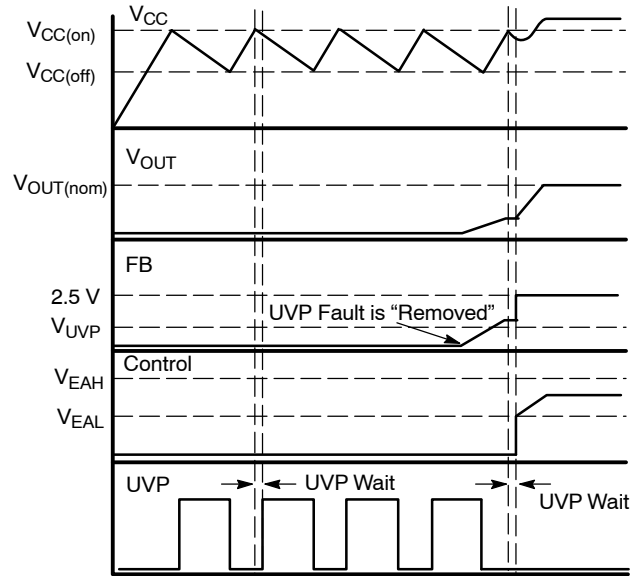

Figure 36. The NCP1606's Startup Sequence with and without a UVP Fault

The voltage on the output which exits a UVP fault is given by:

$$V_{OUT(UVP)} = \frac{R_{OUT1} + R_{OUT2}}{R_{OUT2}} \cdot 300 \text{ mV} \quad (\text{eq. 13})$$

If $R_{OUT1} = 1.9 \text{ M}\Omega$ and $R_{OUT2} = 12.0 \text{ k}\Omega$, then the $V_{OUT(UVP)}$ threshold is 48 V. This corresponds to an input voltage of approximately 34 Vac.

Overcurrent Protection (OCP)

A dedicated pin on the NCP1606 senses the peak current and limits the driver on time if this current exceeds $V_{CS(limit)}$. This level is 1.7 V (typ) on the NCP1606A and 0.5 V (typ) on the NCP1606B. Therefore, the maximum peak current can be adjusted by changing R_{SENSE} according to:

$$I_{peak} = \frac{V_{CS(limit)}}{R_{SENSE}} \quad (\text{eq. 14})$$

An internal LEB filter (Figure 37) reduces the likelihood of switching noise falsely triggering the OCP limit. This filter blanks out the first 250 ns (typical) of the current sense signal. If additional filtering is necessary, a small RC filter can be added between R_{SENSE} and the CS pin.

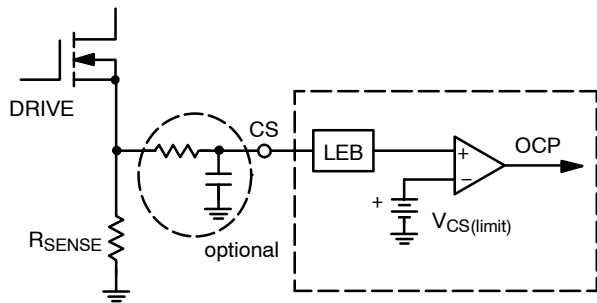

Figure 37. OCP Circuitry with Optional External RC Filter

SHUTDOWN MODE

The NCP1606 allows for two methods to place the controller into a standby mode of operation. The FB pin can be pulled below the UVP level (0.3 V typical) or the ZCD pin can be pulled below the V_{SDL} level (typically 200 mV). If the FB pin is used for shutdown (Figure 38(a)), care must be taken to ensure that no significant leakage current exists on the shutdown circuitry. This could impact the output voltage regulation. If the ZCD pin is used for shutdown (Figure 38(b)), then any parasitic capacitance created by the shutdown circuitry will add to the delay in detecting the zero inductor current event.

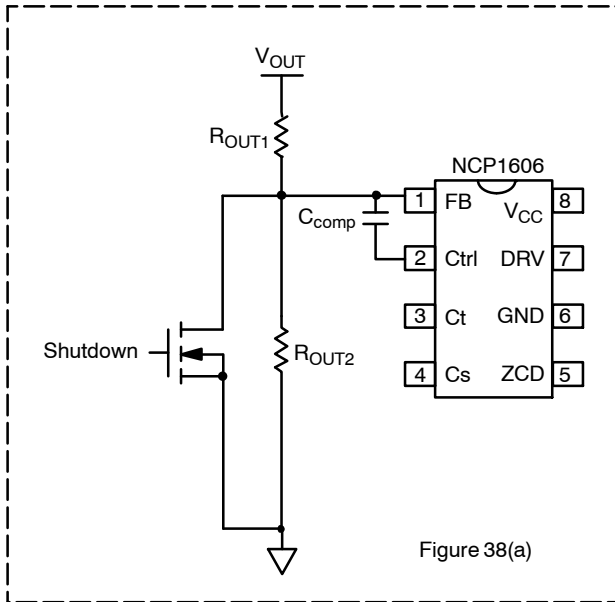

Figure 38(a)

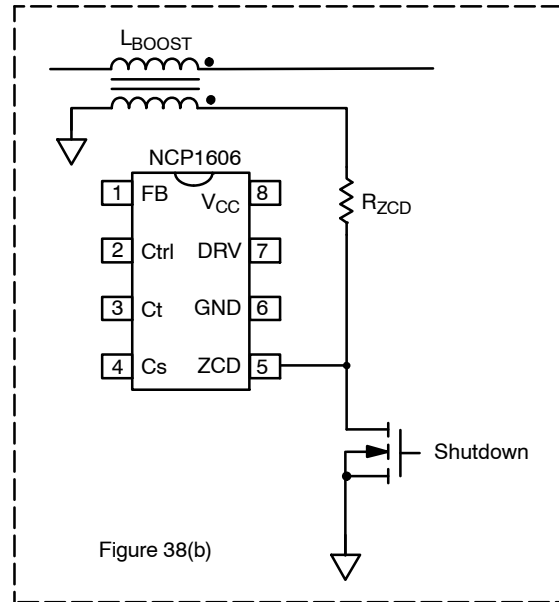

Figure 38(b)

Figure 38. Shutting Down the PFC Stage by Pulling FB to GND (A) or Pulling ZCD to GND (B)

To activate the shutdown feature on ZCD, the internal clamp must first be overcome. This clamp will draw a maximum of $I_{CL(NEG)}$ (5.0 mA maximum) before releasing and allowing the ZCD pin voltage to drop low enough to shutdown the part (Figure 39). After shutdown, the

comparator includes approximately 90 mV of hysteresis to ensure noise free operation. A small current source (70 μ A typ) is also activated to pull the unit out of the shutdown condition when the external pull down is released.

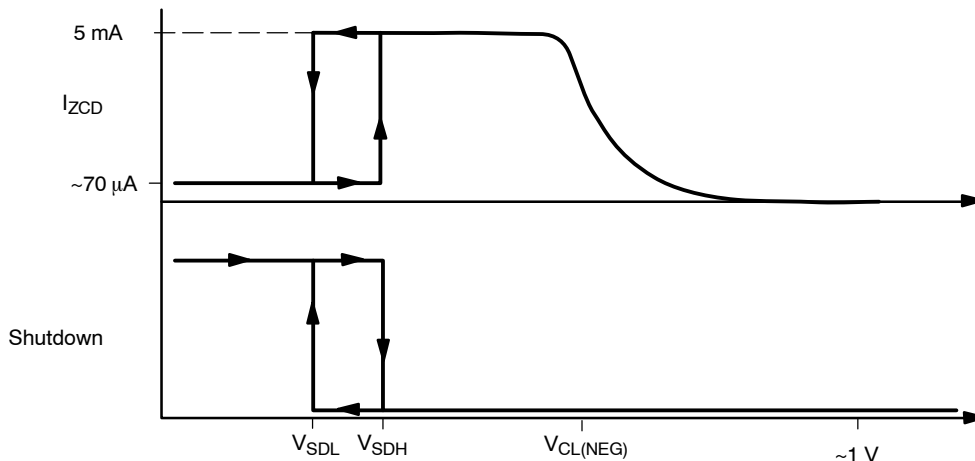

Figure 39. Shutdown Comparator and Current Draw to Overcome Negative Clamp

NCP1606

BOOST DESIGN EQUATIONS Components are identified in Figure 1

RMS Input Current	$I_{ac(rms)} = \frac{P_{OUT}}{\eta \cdot V_{ac(rms)}}$	η (the efficiency of only the Boost PFC stage) is generally in the range of 90 – 95%
Maximum Inductor Peak Current	$I_{pk(max)} = \frac{2 \cdot \sqrt{2} \cdot P_{OUT}}{\eta \cdot Vac_{LL}}$	$I_{pk(max)}$ occurs at the lowest line voltage.
Inductor Value	$L \leq \frac{2 \cdot Vac^2 \cdot \left(\frac{V_{OUT}}{\sqrt{2}} - Vac \right)}{V_{OUT} \cdot Vac \cdot I_{pk(max)} \cdot f_{SW(min)}}$	$f_{SW(min)}$ is the minimum desired switching frequency. The maximum L must be calculated at low line and high line.
Maximum On Time	$t_{ON(max)} = \frac{2 \cdot L \cdot P_{OUT}}{\eta \cdot Vac_{LL}^2}$	The maximum on time occurs at the lowest line voltage and maximum output power.
Off Time	$t_{OFF} = \frac{t_{ON}}{\frac{V_{OUT}}{Vac_{(rms)} \cdot \sin(\theta) \cdot \sqrt{2}} - 1}$	The off time is greatest at the peak of the AC line voltage and approaches zero at the AC line zero crossings. Theta (θ) represents the angle of the AC line voltage.
Frequency	$f_{SW} = \frac{Vac_{(rms)}^2 \cdot \eta}{2 \cdot L \cdot P_{OUT}} \cdot \left(1 - \frac{Vac_{(rms)} \cdot \sin \theta \cdot \sqrt{2}}{V_{OUT}} \right)$	
Pin 3 Capacitor	$C_t \geq \frac{2 \cdot P_{OUT} \cdot L \cdot I_{CHARGE}}{\eta \cdot Vac_{RMS}^2 \cdot V_{CTMAX}}$	I_{CHARGE} and V_{CTMAX} are given in the NCP1606 specification table.
Boost Turns to ZCD Turns Ratio	$N_B : N_{ZCD} \leq \frac{V_{OUT} - Vac_{HL} \cdot \sqrt{2}}{V_{ZCDH}}$	The turns ratio must be low enough so as to trigger the ZCD comparators at high line.
Resistor from ZCD winding to the ZCD pin (pin 5)	$R_{ZCD} \geq \frac{Vac_{HL} \cdot \sqrt{2}}{I_{CL(NEG)} \cdot (N_B : N_{ZCD})}$	R_{ZCD} must be large enough so that the shutdown comparator is not inadvertently activated.
Boost Output Voltage	$V_{OUT(nom)} = 2.5 V \cdot \frac{R_{OUT1} + R_{OUT2}}{R_{OUT2}}$	
Maximum V_{OUT} voltage prior to OVP activation and the necessary R_{OUT1} and R_{OUT2} .	$V_{OUT(max)} = V_{OUT(nom)} + R_{OUT1} \cdot I_{OVP}$ $R_{OUT1} = \frac{V_{OUT(max)} - V_{OUT(nom)}}{I_{OVP}}$ $R_{OUT2} = \frac{2.5 V \cdot R_{OUT1}}{V_{OUT(nom)} - 2.5 V}$	I_{OVP} is given in the NCP1606 specification table. I_{OVP} is lower for the NCP1606B, then for the NCP1606A version.
Minimum output voltage necessary to exit under-voltage protection (UVP)	$V_{OUT(UVP)} = \frac{R_{OUT1} + R_{OUT2}}{R_{OUT2}} \cdot V_{UVP}$	V_{UVP} is given in the NCP1606 specification table.
Bulk Cap Ripple	$V_{ripple(pk-pk)} = \frac{P_{OUT}}{C_{bulk} \cdot 2 \cdot \pi \cdot f_{line} \cdot V_{OUT}}$	Use $f_{line} = 47$ Hz for worst case at universal lines. The ripple must not exceed the OVP level for V_{OUT} .
Inductor RMS Current	$I_{coilRMS} = \frac{2 \cdot P_{OUT}}{\sqrt{3} \cdot Vac_{LL} \cdot \eta}$	
Boost Diode RMS Current	$I_{dMAX(rms)} = \frac{4}{3} \cdot \sqrt{\frac{2 \cdot \sqrt{2}}{\pi}} \cdot \frac{P_{OUT}}{\eta \cdot \sqrt{Vac_{LL} \cdot V_{OUT}}}$	
MOSFET RMS Current	$I_{M(rms)} = \frac{2}{\sqrt{3}} \cdot \frac{Pin}{Vac} \cdot \sqrt{1 - \left(\frac{8 \cdot \sqrt{2} \cdot Vac}{3 \pi \cdot V_{OUT}} \right)^2}$	

NCP1606

BOOST DESIGN EQUATIONS

Components are identified in Figure 1

MOSFET Sense Resistor	$R_{\text{SENSE}} = \frac{V_{\text{CS(limit)}}}{I_{\text{pk}}}$ $P_{\text{RSENSE}} = I_{\text{M(rms)}}^2 \cdot R_{\text{SENSE}}$	$V_{\text{CS(limit)}}$ is given in the NCP1606 specification table. The NCP1606B has a lower $V_{\text{CS(limit)}}$ level.
Bulk Capacitor RMS Current	$I_{\text{C(rms)}} = \sqrt{\frac{32 \cdot \sqrt{2} \cdot P_{\text{OUT}}^2}{9 \cdot \pi \cdot \text{Vac}_{\text{LL}} \cdot V_{\text{OUT}} \cdot \eta^2} - (I_{\text{LOAD(rms)}})^2}$	
Type 1 C_{COMP}	$C_{\text{COMP}} = \frac{10^{G/20}}{4 \cdot \pi \cdot f_{\text{line}} \cdot R_{\text{OUT1}}}$	G is the desired attenuation in decibels (dB). Typically it is 60 dB.

ORDERING INFORMATION

Device	Vcs(limit) (typ) (Note 5)	I _{OVP} (typ) (Note 5)	Package	Shipping [†]
NCP1606APG	1.7 V	40 μA	PDIP-8	50 Units / Rail
NCP1606ADR2G	1.7 V	40 μA	SOIC-8	2500 / Tape & Reel
NCP1606BPG	0.5 V	10 μA	PDIP-8	50 Units / Rail
NCP1606BDR2G	0.5 V	10 μA	SOIC-8	2500 / Tape & Reel

5. See the electrical specifications section for complete information on V_{CS} and I_{OVP} .

[†]For information on tape and reel specifications, including part orientation and tape sizes, please refer to our Tape and Reel Packaging Specification Brochure, BRD8011/D.

NCP1606

PACKAGE DIMENSIONS

SOIC-8 NB
CASE 751-07
ISSUE AJ

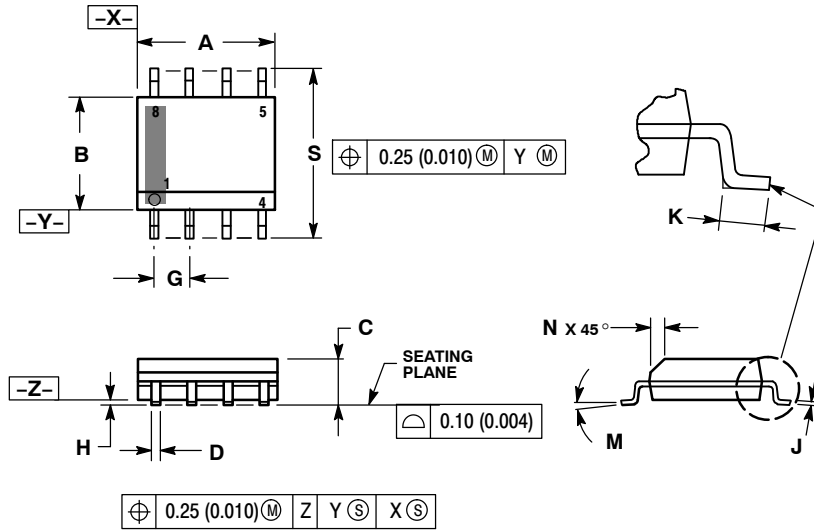

NOTES:

1. DIMENSIONING AND TOLERANCING PER ANSI Y14.5M, 1982.
2. CONTROLLING DIMENSION: MILLIMETER.
3. DIMENSION A AND B DO NOT INCLUDE MOLD PROTRUSION.
4. MAXIMUM MOLD PROTRUSION 0.15 (0.006) PER SIDE.
5. DIMENSION D DOES NOT INCLUDE DAMBAR PROTRUSION. ALLOWABLE DAMBAR PROTRUSION SHALL BE 0.127 (0.005) TOTAL IN EXCESS OF THE D DIMENSION AT MAXIMUM MATERIAL CONDITION.
6. 751-01 THRU 751-06 ARE OBSOLETE. NEW STANDARD IS 751-07.

DIM	MILLIMETERS		INCHES	
	MIN	MAX	MIN	MAX
A	4.80	5.00	0.189	0.197
B	3.80	4.00	0.150	0.157
C	1.35	1.75	0.053	0.069
D	0.33	0.51	0.013	0.020
G	1.27 BSC		0.050 BSC	
H	0.10	0.25	0.004	0.010
J	0.19	0.25	0.007	0.010
K	0.40	1.27	0.016	0.050
M	0°	8°	0°	8°
N	0.25	0.50	0.010	0.020
S	5.80	6.20	0.228	0.244

SOLDERING FOOTPRINT*

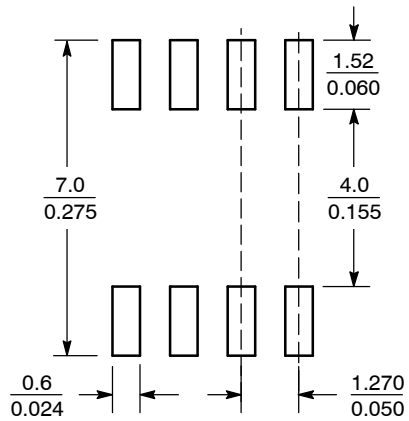

SCALE 6:1 $\left(\frac{\text{mm}}{\text{inches}}\right)$

*For additional information on our Pb-Free strategy and soldering details, please download the ON Semiconductor Soldering and Mounting Techniques Reference Manual, SOLDERRM/D.

NCP1606

PACKAGE DIMENSIONS

8 LEAD PDIP CASE 626-05 ISSUE L

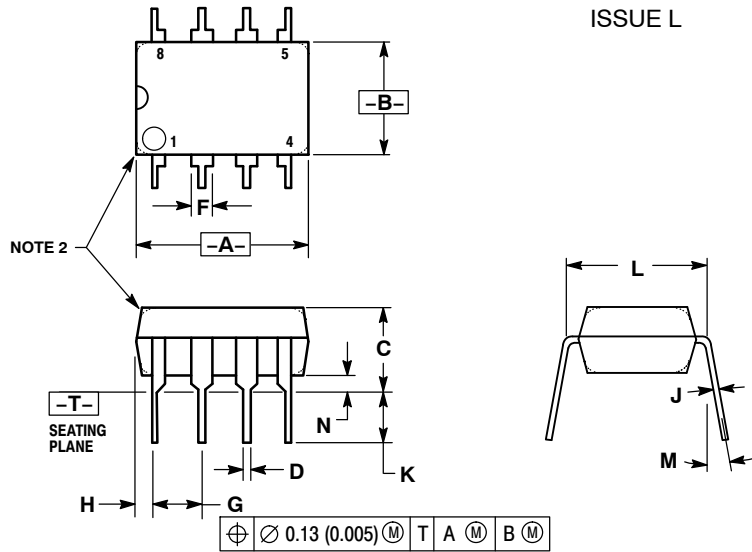

NOTES:

1. DIMENSION L TO CENTER OF LEAD WHEN FORMED PARALLEL.
2. PACKAGE CONTOUR OPTIONAL (ROUND OR SQUARE CORNERS).
3. DIMENSIONING AND TOLERANCING PER ANSI Y14.5M, 1982.

DIM	MILLIMETERS		INCHES	
	MIN	MAX	MIN	MAX
A	9.40	10.16	0.370	0.400
B	6.10	6.60	0.240	0.260
C	3.94	4.45	0.155	0.175
D	0.38	0.51	0.015	0.020
F	1.02	1.78	0.040	0.070
G	2.54 BSC		0.100 BSC	
H	0.76	1.27	0.030	0.050
J	0.20	0.30	0.008	0.012
K	2.92	3.43	0.115	0.135
L	7.62 BSC		0.300 BSC	
M	---	10°	---	10°
N	0.76	1.01	0.030	0.040

The product described herein (NCP1606), may be covered by the following U.S. patents: 5,073,850 and 6,362,067. There may be other patents pending.

ON Semiconductor and **ON** are registered trademarks of Semiconductor Components Industries, LLC (SCILLC). SCILLC reserves the right to make changes without further notice to any products herein. SCILLC makes no warranty, representation or guarantee regarding the suitability of its products for any particular purpose, nor does SCILLC assume any liability arising out of the application or use of any product or circuit, and specifically disclaims any and all liability, including without limitation special, consequential or incidental damages. "Typical" parameters which may be provided in SCILLC data sheets and/or specifications can and do vary in different applications and actual performance may vary over time. All operating parameters, including "Typicals" must be validated for each customer application by customer's technical experts. SCILLC does not convey any license under its patent rights nor the rights of others. SCILLC products are not designed, intended, or authorized for use as components in systems intended for surgical implant into the body, or other applications intended to support or sustain life, or for any other application in which the failure of the SCILLC product could create a situation where personal injury or death may occur. Should Buyer purchase or use SCILLC products for any such unintended or unauthorized application, Buyer shall indemnify and hold SCILLC and its officers, employees, subsidiaries, affiliates, and distributors harmless against all claims, costs, damages, and expenses, and reasonable attorney fees arising out of, directly or indirectly, any claim of personal injury or death associated with such unintended or unauthorized use, even if such claim alleges that SCILLC was negligent regarding the design or manufacture of the part. SCILLC is an Equal Opportunity/Affirmative Action Employer. This literature is subject to all applicable copyright laws and is not for resale in any manner.

PUBLICATION ORDERING INFORMATION

LITERATURE FULFILLMENT:
Literature Distribution Center for ON Semiconductor
P.O. Box 5163, Denver, Colorado 80217 USA
Phone: 303-675-2175 or 800-344-3860 Toll Free USA/Canada
Fax: 303-675-2176 or 800-344-3867 Toll Free USA/Canada
Email: orderlit@onsemi.com

N. American Technical Support: 800-282-9855 Toll Free
USA/Canada
Europe, Middle East and Africa Technical Support:
Phone: 421 33 790 2910
Japan Customer Focus Center
Phone: 81-3-5773-3850

ON Semiconductor Website: www.onsemi.com
Order Literature: <http://www.onsemi.com/orderlit>

For additional information, please contact your local Sales Representative

AMEYA360

Components Supply Platform

Authorized Distribution Brand :



Website :

Welcome to visit www.ameya360.com

Contact Us :

➤ Address :

401 Building No.5, JiuGe Business Center, Lane 2301, Yishan Rd
Minhang District, Shanghai , China

➤ Sales :

Direct +86 (21) 6401-6692

Email amall@ameya360.com

QQ 800077892

Skype [ameyasales1](#) [ameyasales2](#)

➤ Customer Service :

Email service@ameya360.com

➤ Partnership :

Tel +86 (21) 64016692-8333

Email mkt@ameya360.com